

GENERAL DESCRIPTION

The XRP6657 Evaluation Board is designed to help the user evaluate the performance of the XRP6657 for use as a single Li-Ion battery Step-Down DC-DC Converter.

The XRP6657 operates from 2.5V to 5.5V input, with the highest efficiency in the range 3.0V to 4.2V where the Li-Ion battery has the most energy.

The XRP6657 evaluation board is a complete power supply circuit to provide ease of evaluation for the DC/DC converter performance. The Evaluation Board schematic diagram is shown in Figure 1.

EVALUATION BOARD MANUAL

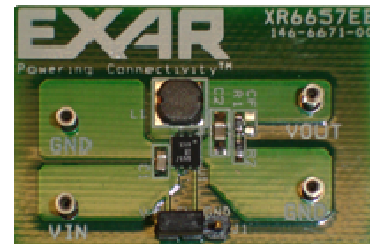

FEATURES

- **Guaranteed 1.5A Output Current**
 - Fixed 1.3MHz Frequency PWM Operations
 - Up to 95% efficiency
- **Adjustable Output Voltage**
- **Internal Compensation Network**
- **No Schottky Diode Required**
- **LDO Operation: 100% Duty Cycle**
- **Over-current/Over-temperature Protection**
- **“Green”/Halogen Free DFN-6 Package**

EVALUATION BOARD SCHEMATICS

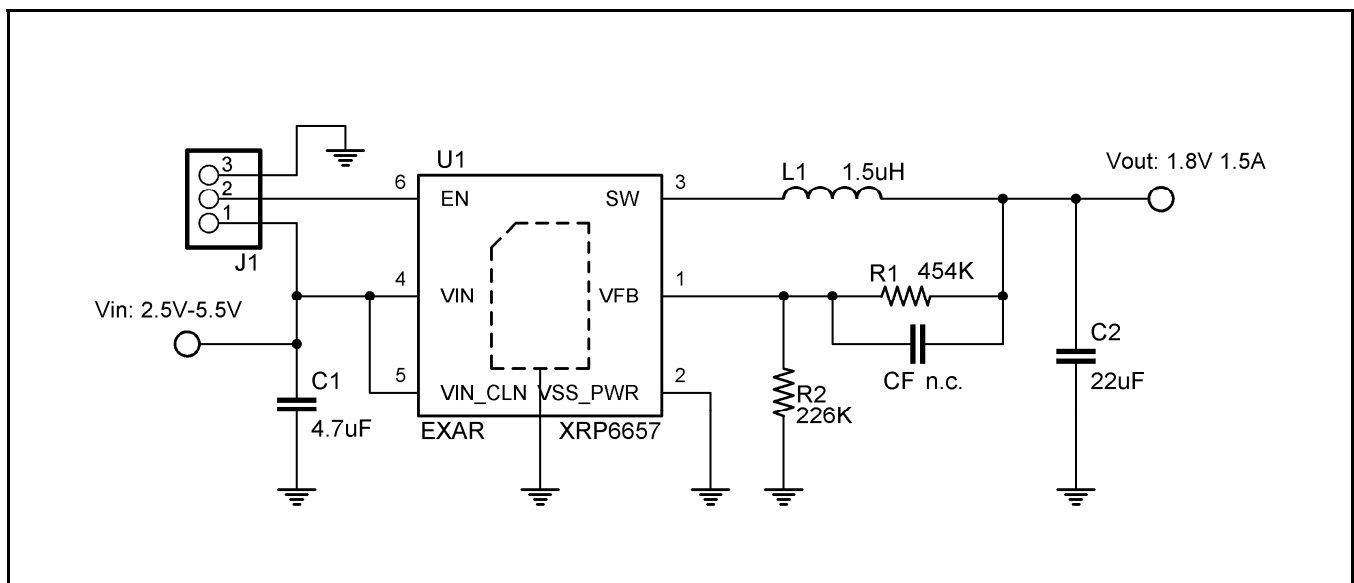

Fig. 1: XRP6657 Evaluation Board Schematics

PIN ASSIGNMENT

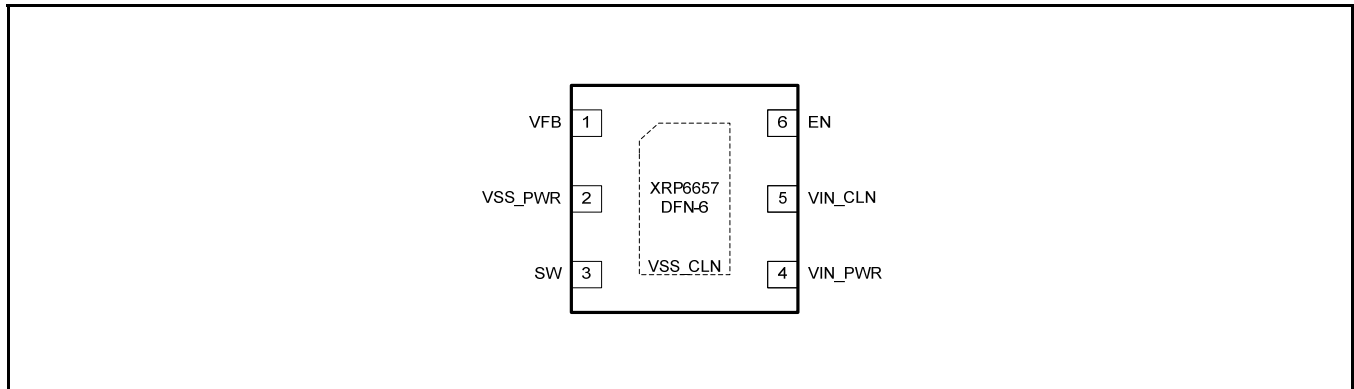

Fig. 2: XRP6657 Pin Assignment

PIN DESCRIPTION

Name	Pin Number	Description
VFB	1	Feedback Pin. Receives the feedback voltage from an external resistive divider across the output.
VSS_PWR	2	Power Ground Pin.
SW	3	Switching node. Must be connected to inductor. This pin connects to the drains of the internal main and synchronous power MOSFET switches.
VIN_PWR	4	Power Input Pin. Must be closely decoupled to ground pin with a 4.7µF or greater capacitor.
VIN_CLN	5	Analog Input Pin. Must be closely decoupled to ground pin with a 4.7µF or greater capacitor.
EN	6	Enable Pin. >1.2V: Enables the XRP6657 <0.4V: Disables the XRP6657 Do not leave this pin floating and enable the device once Vin is in the operating range.
VSS_CLN	Exposed Pad	Analog Ground Pin.

ORDERING INFORMATION

Refer to XRP6657’s datasheet and/or www.exar.com for exact and up to date ordering information.

USING THE EVALUATION BOARD

POWERING UP THE XRP6657 CIRCUIT

The XRP6657 Evaluation Board can be powered from a single Li-Ion battery or a +2.5V to +5.5V power supply. Connect with short leads directly to the "Vin" and "Gnd" posts. Note the XRP6657 will remain in "shutdown" until the "RUN" Jumper J1 is applied to the Vin or position 1 to 2.

OUTPUT VOLTAGE PROGRAMMING

The XRP6657 has a dynamically programmable output voltage using 2 feedback resistors to control the output voltage:

$$R_1 = \left(\frac{V_{OUT}}{0.6} - 1\right) \times R_2 \quad \text{or} \quad V_{OUT} = 0.6V \times \left(1 + \frac{R_1}{R_2}\right)$$

TYPICAL PERFORMANCE CHARACTERISTICS

All data taken at $V_{IN} = 3.6V$ and $V_{OUT} = 1.8V$, unless otherwise specified.

The XRP6657 evaluation board efficiency and regulation are shown in figure 4 & 5. The efficiency is over 92% for 2.5V input. The output load regulation is less than 0.2% throughout the Vin ranges. The output start up response is shown in figure 6 & 7. The output transient response is shown in figure 6, 7 & 8 and show that the output deviation has less than 240mV at 80% load step, and less than 170mV at 50% load step. See figures below for more details:

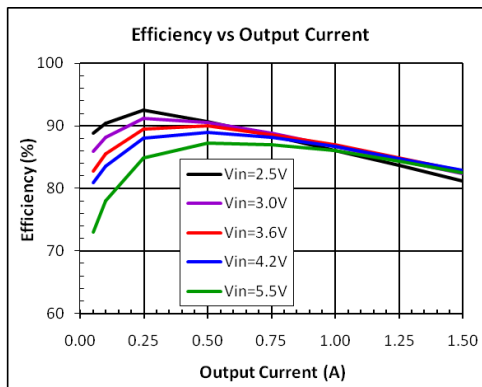

Fig. 3: Efficiency vs Output Current (A)

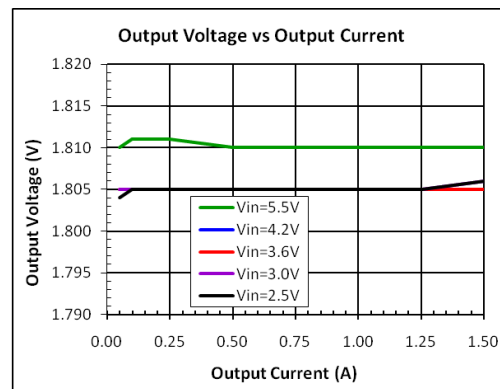

Fig. 4: Output Regulation vs Output Current (A)

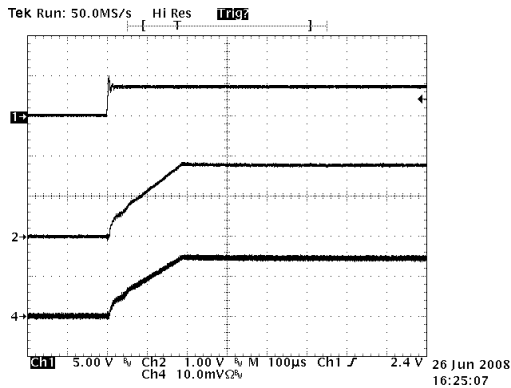

Fig. 5: Start Up Response (1.5A)

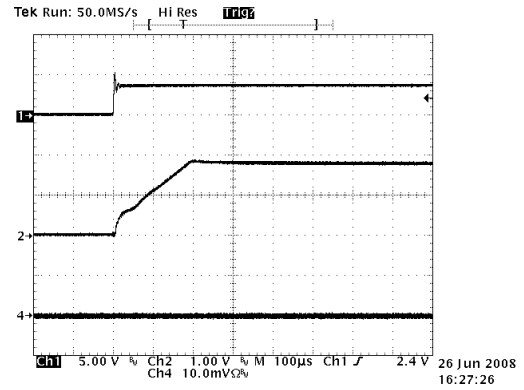

Fig. 6: Start Up Response (no load)

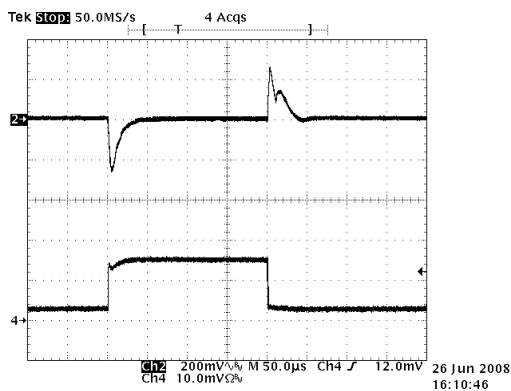

Fig. 7: Output Transient Response
0.25A to 1.5A

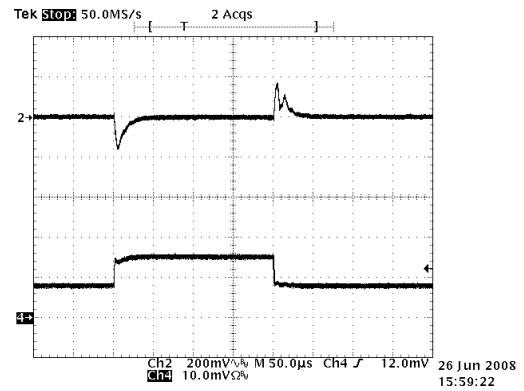

Fig. 8: Output Transient Response
0.75A to 1.5A

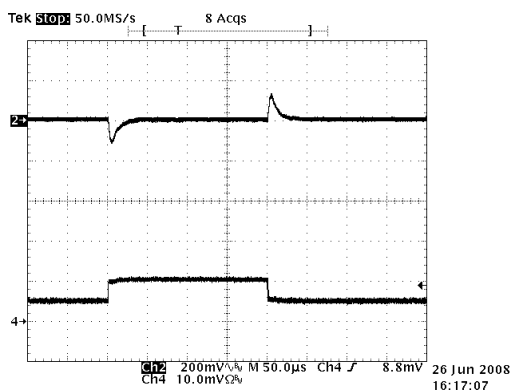

Fig. 9: Output Transient Response
0.25A to 1.0A

EVALUATION BOARD LAYOUT

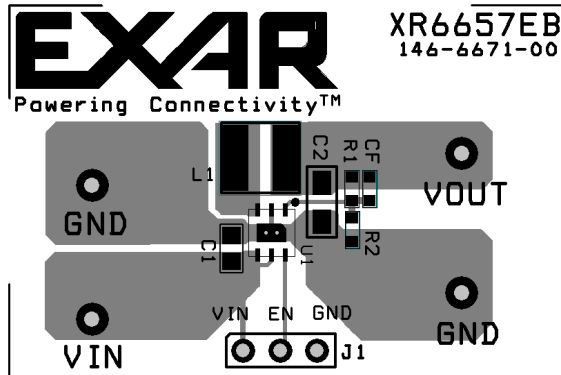

Fig. 10: XRP6657 Evaluation Board Component Placement and Component Side Lay Out

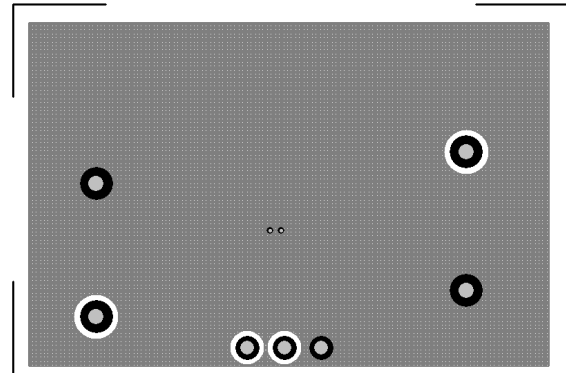

Fig. 11: XRP6657 Evaluation Board Soldier Side Lay Out

BILL OF MATERIAL

Ref.	Qty	Manufacturer	Part Number	Size	Component	Vendor
Board	1	Exar Corp.	146-6671-00	1"x1.5"	XRP6657 Eval board	Exar Corp.
U1	1	Exar Corp.	XRP6657IHB-F	TDFN-6L	1.5A Buck Regulator.	Exar Corp.
C1	1	Murata	GRM219R61A475K	0805	Ceramic 4.7µF 10V X5R	Murata.com
C2	1	Murata	GRM219R60J226M	0805	Ceramic 22µF 6.3V X5R	Murata.com
L1	1	Inter-Technical	SD52-1R5M	4.5x5x2mm	1.5µH 2.5A 47mΩ DCR	Inter-technical.com
R1	1	Vishay	CRCW0603454K00F	0603	454KΩ, 1/10W, 1%	Vishay.com
R2	1	Vishay	CRCW0603226K00F	0603	226KΩ, 1/10W, 1%	Vishay.com
J1	1	Würth Electronic	61303611121	0.23x0.12	3 Pin Header	We-online.com
	1	Würth Electronic	60900213421	0.2x0.1	Shunt	We-online.com
TP	3	Mill-Max	0300-115-01-4727100	0.042" dia	Test Point Female Pin	800-digi-key



REVISION HISTORY

Revision	Date	Description
1.0.0	07/14/09	Initial release of document

FOR FURTHER ASSISTANCE

Email: customersupport@exar.com
Exar Technical Documentation: <http://www.exar.com/TechDoc/default.aspx?>

EXAR CORPORATION

HEADQUARTERS AND SALES OFFICES

48720 Kato Road
Fremont, CA 94538 – USA
Tel.: +1 (510) 668-7000
Fax: +1 (510) 668-7030
www.exar.com



NOTICE

EXAR Corporation reserves the right to make changes to the products contained in this publication in order to improve design, performance or reliability. EXAR Corporation assumes no responsibility for the use of any circuits described herein, conveys no license under any patent or other right, and makes no representation that the circuits are free of patent infringement. Charts and schedules contained here in are only for illustration purposes and may vary depending upon a user's specific application. While the information in this publication has been carefully checked; no responsibility, however, is assumed for inaccuracies.

EXAR Corporation does not recommend the use of any of its products in life support applications where the failure or malfunction of the product can reasonably be expected to cause failure of the life support system or to significantly affect its safety or effectiveness. Products are not authorized for use in such applications unless EXAR Corporation receives, in writing, assurances to its satisfaction that: (a) the risk of injury or damage has been minimized; (b) the user assumes all such risks; (c) potential liability of EXAR Corporation is adequately protected under the circumstances.

Reproduction, in part or whole, without the prior written consent of EXAR Corporation is prohibited.

X-ON Electronics

Largest Supplier of Electrical and Electronic Components

Click to view similar products for [Exar](#) manufacturer:

Other Similar products are found below :

[LP2950CN-L-5-0](#) [SP6200EM5-L-3-0](#) [SPX3819S-L-1-2](#) [SP337EBET-L](#) [SPX385N-L-2-5](#) [SP3238ECA-L/TR](#) [SP337EUET-0A-EB](#)
[SP338EER1-0A-EB](#) [SP485EMN-L/TR](#) [XR1009ISO8EVB](#) [XR10910IL40EVB](#) [XR16M780IM48-F](#) [XR16M890IM48-0C-EB](#)
[XR17V358/SP339-E4-EB](#) [XR17V358/SP339-E8-EB](#) [XR2008ISO8EVB](#) [XR2009IMP8EVB](#) [XR20M1170G16-0A-EB](#) [XR20M1172G28-0A-EB](#) [XR20M1172L32-0A-EB](#) [XR20M1172L32-0B-EB](#) [XR20M1280L24-0A-EB](#) [XR76121EVB](#) [XRP9711EVB-DEMO-1-KITA](#) [XRP6275EH-F](#) [SP337EUCY-L](#) [SP211ECT-L](#) [XR21B1422IL40-0A-EVB](#) [SP337EBEY-0A-EB](#) [SP3232EBCA-L/TR](#) [XR17D152CM-0A-EVB](#)
[XR17V352IB-0A-EVB](#) [XRP2526EVB](#) [XRP9711EVB-DEMO-1](#) [XRP7714EVB-ZYNQ-1](#) [MXL7204EVB](#) [XR76208EVB-Q](#) [XR76203EVB-Q](#)
[XR22414CL48EVB](#) [CAB-LFH-V16A4S0](#) [SP337EUEY-0A-EB](#) [SP7600EB](#) [XR17D158CV-0A-EVB](#) [XR20M1170G16-0B-EB](#)
[XR20M1170G24-0B-EB](#) [XRA1402IL16-0B-EB](#) [XRP7659EVB](#) [XRP77XXEVB-XPM](#) [XR16V2550IL-F](#) [ST16C2450IJ44-F](#)