



PRODUCT SPECIFICATION SHEET

Customer			
Customer P/N			
Product Type	Temperature-Compensated Crystal Oscillator		
Failong Part Number	9T26000028	Version	S0
Part Description	SMD TCXO 2.0 X 1.6		
Nominal Frequency	26.000000MHz		

Prepared	Kuro Peng
Reviewed	Kuro Peng
Approved	Jay Lee
Date	2019/9/9

Customer's Approval & Date :

广东惠伦晶体科技股份有限公司

GUANGDONG FAILONG CRYSTAL TECHNOLOGY CO., LTD.

中国广东省东莞市黄江镇东环路鸡啼岗段36号

36 Donghuan Road, Jitigang Village, Huangjiang,

Dongguan, Guangdong Province, P. R. China

WEB : <http://www.dgylec.com/>

TEL : +86 (0) 769-38879888

FAX : +86 (0) 769-38879889

EMAIL : yl@dgylec.com

MSL 1



History of Specification Revision

Ver.	Contents	Date	Reviser	NOTE
S0	Initial released	2019/9/9	Kuro Peng	

1. Product Specifications

1.1 Operation conditions

#	Parameters	Min.	Typ.	Max.	Unit	Note
1	Nominal frequency		26.0		MHz	
2	Supply voltage	1.71	1.8	1.89	V	
3	Current consumption	-	-	2	mA	
4	Operating temperature range	-40	-	85	°C	
5	Storage temperature range	-40	-	95	°C	

1.2 Output characteristics

#	Parameters	Min.	Typ.	Max.	Unit	Note	
1	Output type	Clipped sine wave			-	Decoupling capacitor is required in external circuit	
2	Standard output Load	10 KΩ//10 pF			-		
3	Output level	0.8	-	-	V _{pp}		
4	Harmonics	-	-	-5	dBc		
5	Start-up time	vs. frequency	-	-	2.0	ms	Within ±0.5 ppm
6		vs. output level	-	-	2.0	ms	≥90% of V _{pp}

1.3 Frequency characteristics

#	Parameters	Min.	Typ.	Max.	Unit	Note	
1	Nominal frequency	-	26.0	-	MHz		
2	Frequency tolerance after reflow	-2.0	-	+2.0	ppm	At 25±2°C after 2 times reflow, refer to nominal frequency	
3	Frequency stability	vs. temperature	-0.5	-	+0.5	ppm	Refer to frequency at 25°C within operating temperature range
4		vs. supply voltage	-0.1	-	+0.1	ppm	±5% V _{cc} variation
5		vs. load variation	-0.1	-	+0.1	ppm	±5% load variation
6	Auto frequency control (AFC) range	-12.0	-	-8.0	ppm	V _{cont} = 0.3V	
		+8.0	-	+12.0	ppm	V _{cont} = 1.5V	
7	Slope of frequency drift over temperature	-0.2	-	+0.2	ppm/°C		
8	Duty Cycle	40	50	60	%		
9	Aging over 1st year	-1.0	-	+1.0	ppm		

1.4 Phase noise characteristics

#	Parameters	Min.	Typ.	Max.	Unit	Note
1	At 1kHz offset	-	-135	-	dBc/Hz	At 25±2°C
2	At 100kHz offset	-	-152	-	dBc/Hz	

2. Product Design

2.1 Dimensions (unit: mm)

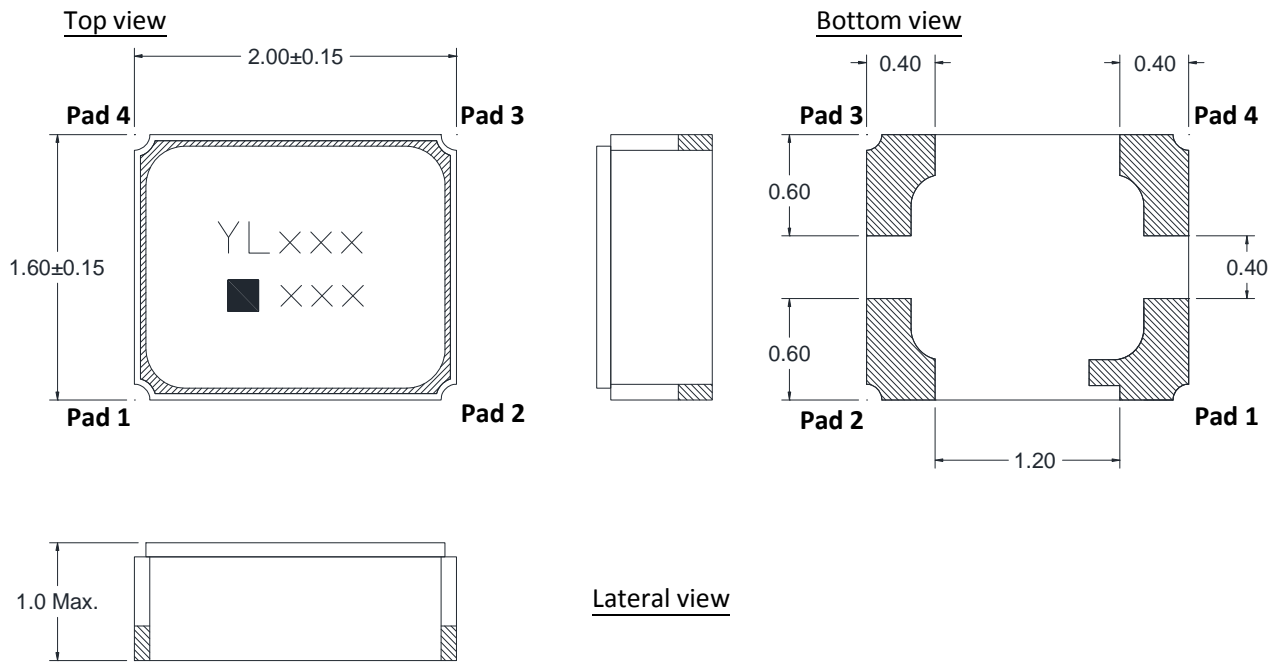

2.2 Pad connections and functions

Pad	Function
1	AFC
2	GND
3	Output
4	Vcc

2.3 Recommended land pattern (unit: mm)

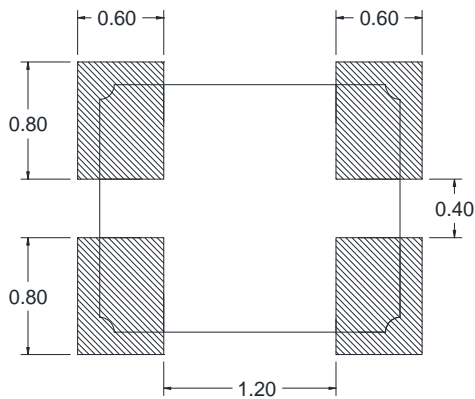

3. Testing Circuit

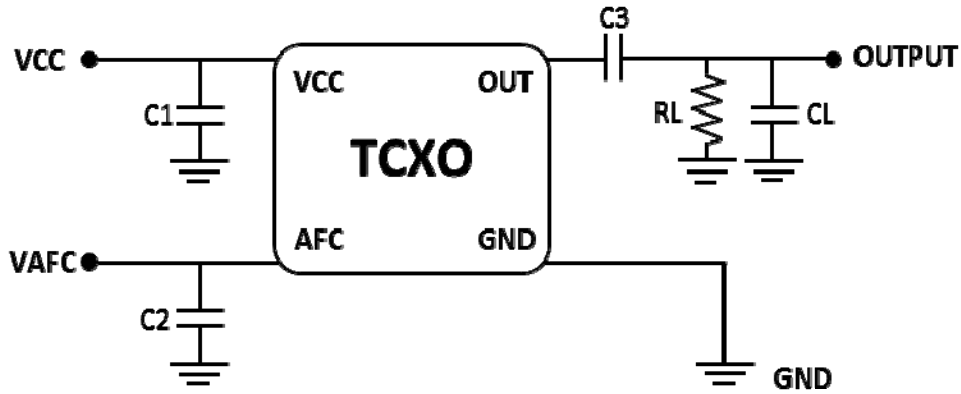

External Components:

Parts	Function
C1	AC noise bypass for VCC
C2	AC Noise Bypass for AFC
C3	DC block for output
RL	Load resistance
CL	Load capacitance

4. Recommended Reflow Profile

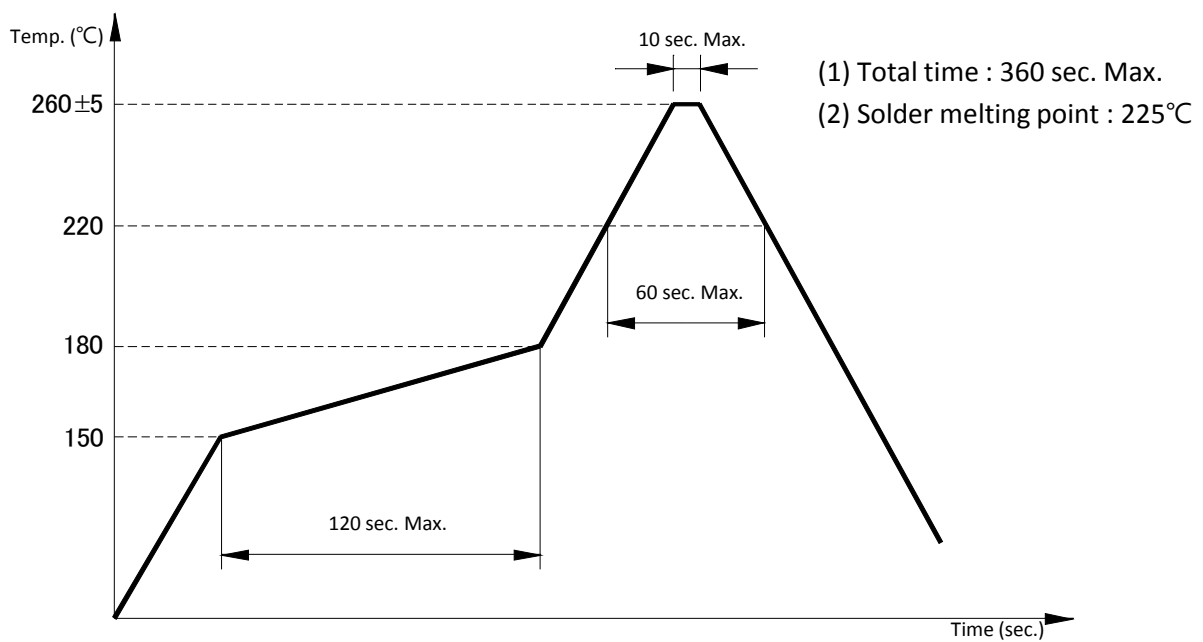

5. Reliability

5.1 Mechanical endurance

#	Item	Test Methods	
		Condition	Reference
1	Drop test	Height : 150 cm height Direction : fall freely Test cycles : 3 cycles Stainless plate	JIS C6701
2	Shock test	Height : 150 cm height Direction : X, Y, Z, 6 directions Test cycles : 3 cycles Concrete floor Mounting on test fixture (total weight=150 g)	IEC-68-02-27
3	Mechanical shock	Acceleration : 1000 g Duration : 1.0 ms Test cycles : 3 times for all 3 directions	MIL-STD-202F
4	Vibration	Acceleration : 20 g Duration : 4 hours/each direction Frequency range : 10 ~ 55 Hz Amplitude : 1.52 mm Direction : X, Y, Z, 3 directions Sweep speed : 20 minutes/cycle	MIL-STD-883E
5	Gross leak	Standard sample for automatic gross leak detector. Test Pressure : 2 kg / cm ²	MIL-STD-883E
6	Fine leak	Helium bombing 4.5 kgf / cm ² for 2 hours	MIL-STD-883E
7	Solderability	Preheated temperature : 125°C ± 5°C Preheated time : 120 sec Soldering temperature : 245°C ± 5°C Duration : 5 ± 1 second Method : Solder bath method	MIL-STD-883E

5. Reliability (Cont.)

5.2 Environmental endurance

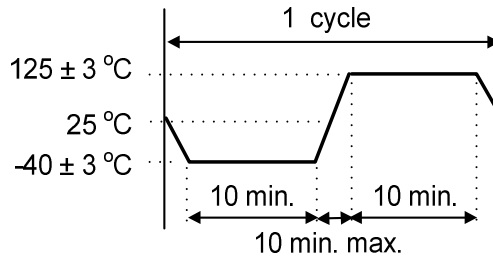
#	Item	Test Methods	
		Condition	Reference
1	High temperature storage	Temperature : $+125^{\circ}\text{C} \pm 3^{\circ}\text{C}$ Duration : 168 hours	MIL-STD-883E
2	Low temperature storage	Temperature : $-40^{\circ}\text{C} \pm 3^{\circ}\text{C}$ Duration : 500 hours	MIL-STD-883E
3	Thermal shock (Air-to-air)	Total 100 cycles of the following temperature cycle : 	MIL-STD-883E
4	High temperature and humidity	Temperature : $85^{\circ}\text{C} \pm 3^{\circ}\text{C}$ Humidity: RH 85% Duration : 168 hours	JIS C5023
5	Aging	Temperature : $85^{\circ}\text{C} \pm 3^{\circ}\text{C}$ Duration : 500 hours Voltage input by specification	JESD22-A108

X-ON Electronics

Largest Supplier of Electrical and Electronic Components

Click to view similar products for [Standard Clock Oscillators](#) category:

Click to view products by [Failong Crystal](#) manufacturer:

Other Similar products are found below :

[EP1400SJTSC-125.000M](#) [601137](#) [601252](#) [CSX750FBC-24.000M-UT](#) [CSX750FBC-33.333M-UT](#) [CSX750FCC-3.6864M-UT](#) [F335-12](#) [F335-25](#) [F535L-50](#) [DSC506-03FM2](#) [ASA-20.000MHZ-L-T](#) [ASA-25.000MHZ-L-T](#) [ASA-27.000MHZ-L-T](#) [ASV-20.000MHZ-LR-T](#) [ECS-2018-160-BN-TR](#) [EL13C7-H2F-125.00M](#) [MXO45HS-2C-66.6666MHZ](#) [NBXDBB017LN1TAG](#) [NBXHBA019LN1TAG](#) [SiT1602BI-22-33E-50.000000E](#) [SIT8003AC-11-33S-2.04800X](#) [SiT8256AC-23-33E-156.250000X](#) [SIT8918AA-11-33S-50.000000G](#) [SM4420TEV-40.0M-T1K](#) [SMA4306-TL-H](#) [F335-24](#) [F335-40](#) [F335-50](#) [F535L-10](#) [F535L-12](#) [F535L-16](#) [F535L-24](#) [F535L-27](#) [F535L-48](#) [PE7744DW-100.0M](#) [CSX750FBC-20.000M-UT](#) [CSX-750FBC33333000T](#) [CSX750FBC-4.000M-UT](#) [CSX750FBC-7.3728M-UT](#) [CSX750FBC-8.000M-UT](#) [CSX-750FCC14745600T](#) [CSX750FCC-16.000M-UT](#) [CSX-750FCC40000000T](#) [CSX750FCC-4.000M-UT](#) [ASA-22.000MHZ-L-T](#) [ASA2-26.000MHZ-L-T](#) [ASA-40.000MHZ-L-T](#) [ASA-48.000MHZ-L-T](#) [ASA-60.000MHZ-L-T](#) [ASF1-3.686MHZ-N-K-S](#)