

## LTE-BLE 5.1/5.2, 802.15.4 Modules, M.2 Connector Draft Ver 0.61 Aug. 2020

LN60E Series modules integrate a Nordic nRF9160 LTE SIP module with a Fanstel BLE 5.1 or BLE 5.2/Thread/Zigbee module, with an u.FI connector for external LTE antenna, an integrated GPS antenna with amplifier or an u.FL for external GPS antenna, a SIM card connector. It allows faster time to market with reduced development cost. Fanstel Bluetooth modules are available with power amplifier, with range > 4500 meters or 2.8 miles.



An M.2 connector, B key is used to connect to the host processor.

### LTE Specifications:

#### Microcontroller:

- ARM® Cortex® -M33
- 1 MB flash, 256 kB low leakage RAM
- ARM® Trustzone®
- ARM® Cryptocell 310
- 2x UART (CTS/RTS)
- 11 GPIOs
- SIM card interface for external ESIM.
- On board nano SIM card connector

#### LTE modem:

- Transceiver and baseband
- 3GPP LTE release 13 Cat-M1 and Cat-NB1 compliant
  - 3GPP release 13 coverage enhancement
- 3GPP LTE release 14 Cat-NB2 compliant
- GPS receiver
  - GPS L1 C/A supported
  - GPS antenna and amplifier integrated
- RF transceiver for global coverage
  - Up to 23 dBm output power
  - -108 dBm sensitivity (LTE-M) for low band, -107 dBm for mid band

- An u.FL connector for external LTE antenna
- LTE band support in hardware:
  - Cat-M1: B1, B2, B3, B4, B5, B8, B12, B13, B14, B17, B18, B19, B20, B25, B26, B28, B66
  - Cat-NB1/NB2: B1, B2, B3, B4, B5, B8, B12, B13, B17, B18, B20, B25, B26, B28, B66
- IP v4/v6 stack
- Secure socket (TLS/DTLS) API

### Bluetooth Specifications

- BLE 5.1/5.2 modules with nRF52840, nRF5340
- BT840X/XE, max. TX at +21 dBm, range over 4500 meters in free space at 125 Kbps.
- USB interface
- UART interface
- 37 GPIOs

#### Miscellaneous

- Operation temperature: -40°C to +85°C
- All necessary clock sources integrated
- Package: for M.2 connector, B Key, 67 pins.
- EV board: EV-LN60E

### LTE and BLE Modules, M.2 Connector

Module	LN60E40F	LN60E840E	LN60G840F	LN60G840XE	LN60E	LN60G
BLE module	BT40F	BT840E	BT840F	BT840XE	None	None
BLE antenna	Integrated	u.FL	Integrated	PA + u.FL		
LTE module	nRF9160 SICA	nRF9160 SICA	nRF9160 SICA	nRF9160 SICA	nRF9160 SICA	nRF9160 SICA
LTE antenna	u.FL	u.FL	u.FL	u.FL	u.FL	u.FL
GPS antenna	u.FL	u.FL	PCB	PCB	u.FL	Integrated
Size, mm	30x42	30x42	30x42	30x42	30x42	30x42
Certifications						
QDID		108621	108621	108621		
Availability	Sample 4Q20	Sample 3Q20	Sample 3Q20	Sample 3Q20	Sample 3Q20	Sample 3Q20

### BLE Modules, M2. Connector

Module	M240E	M240X	M2840E	M2840X	M2840XE
BLE module	BT40E	BT40X	BT840E	BT840X	BT840XE
BLE antenna	u.FL	PA+u.FL+PCB	u.FL	PA+PCB	PA+u.FL
Size, mm	22x42	22x42	22x42	22x42	22x42
Certifications					
QDID				108621	108621
Availability	Sample 4Q20	Sample 1Q21	Sample 3Q20	Sample 3Q20	Sample 3Q20

## Table Of Contents

1. Introduction.....	3
LN60E Series, LTE with Optional BLE 5.1/5.2 Modules.....	3
M240F Series Bluetooth 5.1/5.2 Modules .....	6
2. Product Descriptions .....	7
nRF9160 Specifications.....	7
BT840F.....	8
BT840X.....	9
Mechanical Drawings .....	10
M.2 Connector Pin Assignments .....	12
Pin Function.....	14
3. Codes Development Using Nordic Tools.....	16
Over-The-Air DFU .....	16
SoftDevices .....	16
Development Tools .....	16
Control nRF21540 in BT40X .....	17
Control Skyworks Power Amplifier in BT840X.....	17
4. Application Examples .....	21
BLE to LTE Gateway .....	21
BLE-LoRa to LTE, WiFi, PoE Ethernet Gateway.....	22
5. EV-BLN60E40F Evaluation Board.....	23
Nordic Development Tools.....	24
Android OS Apps .....	24
iOS Apps.....	24
LN60E40F EvaluationBoard Schematics .....	25
6. Miscellaneous.....	27
Cautions, Design Notes, and Installation Notes .....	27
Packaging and Lot Number .....	30
FCC Label .....	30
Revision History .....	31
Contact Us .....	32

## 1. Introduction

LN60E40F Series modules are powerful, highly flexible, ultra low power wireless modules integrating Nordic nRF9160 SIP module and Fanstel BT40F Series BLE 5.1 or BT840F Series BLE 5 module. With an ARM Cortex™ M33F MCU, 1MB flash, 256KB RAM, embedded LTE-M and NB-IoT transceiver, an u.FL connector for external LTE antenna, integrated GPS antenna and amplifier or an u.FL for external GPS antenna, it allows faster time to market with reduced development cost.

### LN60E Series, LTE with Optional BLE 5.1/5.2 Modules

The following is a block diagram of LN60E40F. Module can be standalone, needing only DC power supply and cross connect UART on host board. Or, a host processor can control Bluetooth and LTE interfaces through M.2 connector pins.

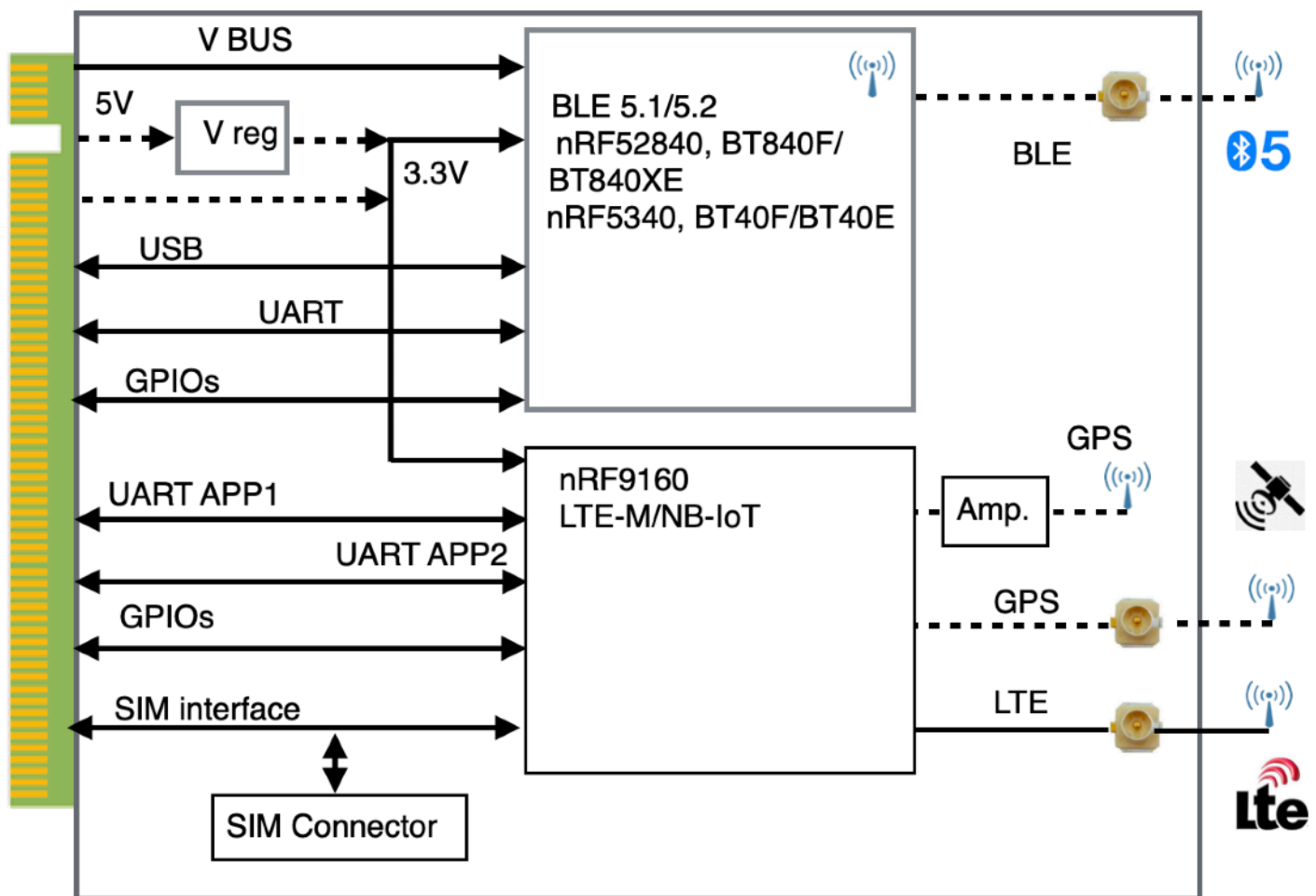

LN60E Series, M.2 Connector B Key. Size 30x42mm

LN60E and LN60G are without Bluetooth module.

Bluetooth interface is not supported by BLN60E as shown in block diagram below. They can be used with:

- M240F Series BLE modules as described in this production specifications.
- New member of M240F series modules, e.g., M240X an nRF5340 module with power amplifier.

- M262E33 Series BLE 5.1/LoRa modules

Modules available in the LN60E40F Series.

## **LN60E**

- nRF9160 SICA SIP module supporting LTE-M and NB-IoT at +23 dBm TX
- An u.FL connector for external LTE antenna
- An u.FL connector for external GPS antenna
- Cortex M33 MCU 1MB flash, 256 KB RAM

## **LN60G**

- nRF9160 SICA SIP module supporting LTE-M and NB-IoT at +23 dBm TX
- An u.FL connector for external LTE antenna
- GPS receiver with integrated amplifier and antenna
- Cortex M33 MCU 1MB flash, 256 KB RAM

## **LN60E40F**

- nRF9160 SICA SIP module supporting LTE-M and NB-IoT at +23 dBm TX
- U.FL connector for external LTE antenna
- GPS receiver with integrated amplifier and antenna
- Cortex M33 MCU 1MB flash, 256 KB RAM
- nRF5340 BLE 5.1 module, BT40F with integrated PCB trace antenna
- Dual code Cortex M33, application core up to 128 MHz.

## **LN60E40E**

- nRF9160 SICA SIP module supporting LTE-M and NB-IoT at +23 dBm TX
- U.FL connector for external LTE antenna
- GPS receiver with integrated amplifier and antenna
- Cortex M33 MCU 1MB flash, 256 KB RAM
- nRF5340 BLE 5.1 module, BT40E with u.FL connector for external antenna
- Dual code Cortex M33, application core up to 128 MHz.

## **LN60E840F**

- nRF9160 SICA SIP module supporting LTE-M and NB-IoT at +23 dBm TX
- U.FL connector for external LTE antenna
- GPS receiver with integrated amplifier and antenna
- Cortex M33 MCU 1MB flash, 256 KB RAM
- BT840F with Integrated PCB trace antenna.
- Bluetooth range is estimated at 3000 meters at 125 Kbps.

## **LN60E840E**

- nRF9160 SICA SIP module supporting LTE-M and NB-IoT at +23 dBm TX
- U.FL connector for external LTE antenna

## **LTE-BLE 5.1/5.2, 802.15.4 Modules, M.2 Connector** Draft Ver 0.61 Aug. 2020

---

- GPS receiver with integrated amplifier and antenna
- Cortex M33 MCU 1MB flash, 256 KB RAM
- BT840E with u.FL for external antenna.
- Bluetooth range with ANT060, 6 dBi antenna, is measured >3400 meters at 125 Kbps.

### **LN60E840X**

- nRF9160 SICA SIP module supporting LTE-M and NB-IoT at +23 dBm TX
- U.FL connector for external LTE antenna
- GPS receiver with integrated amplifier and antenna
- Cortex M33 MCU 1MB flash, 256 KB RAM
- BT840X with Integrated PCB trace antenna.
- Integrated 32.768 kHz sleep crystal
- Bluetooth range is measured >4500 meters or 2.8 miles at 125 Kbps.

### **LN60E840XE**

- nRF9160 SICA SIP module supporting LTE-M and NB-IoT at +23 dBm TX
- U.FL connector for external LTE antenna
- GPS receiver with integrated amplifier and antenna
- Cortex M33 MCU 1MB flash, 256 KB RAM
- BT840XE with an u.FL for external antenna.
- Integrated 32.768 KHz sleep crystal
- Bluetooth range is measured >4500 meters or 2.8 miles at 125 Kbp.

M240F Series Bluetooth 5.1/5.2 Modules

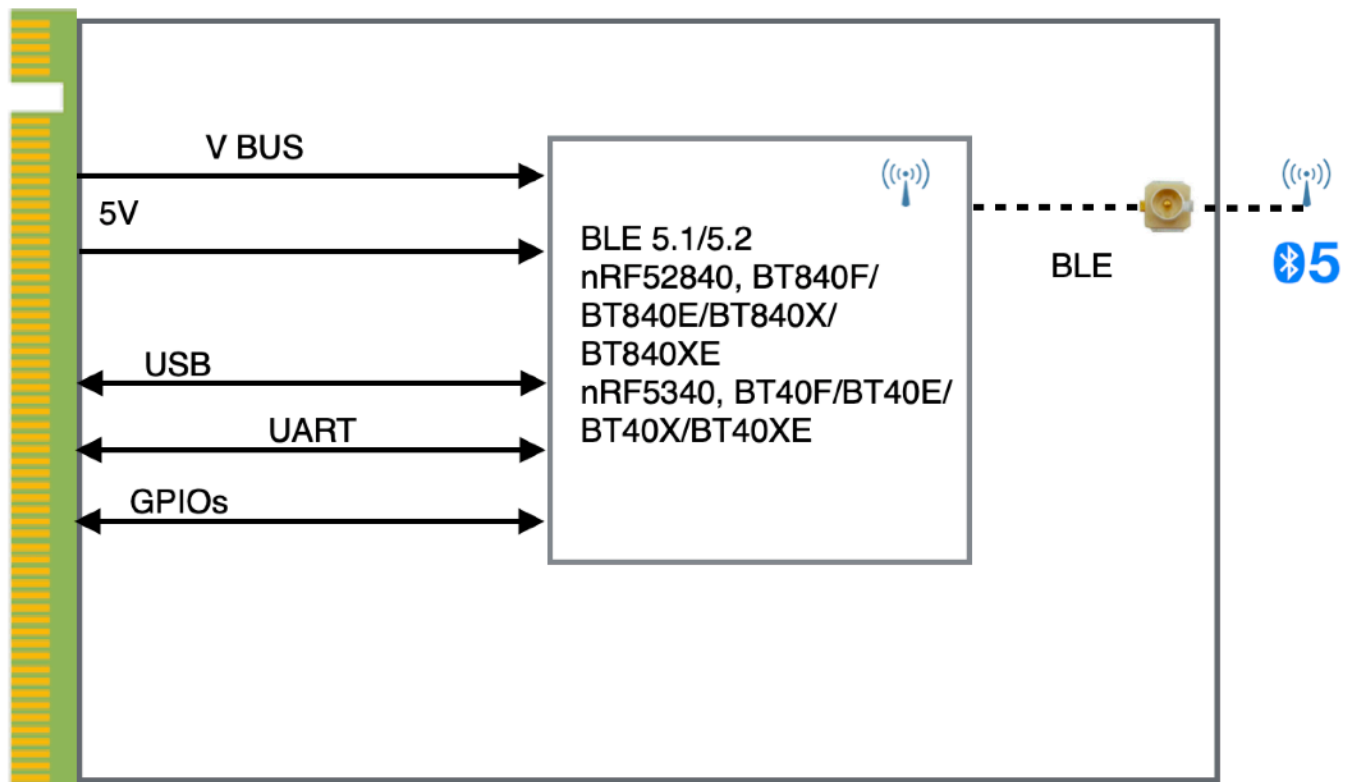

M240F Series, M.2 Connector B Key. Size 22x42mm

## 2. Product Descriptions

### nRF9160 Specifications

nRF9160 SIP module Product Specifications can be downloaded from.

[https://infocenter.nordicsemi.com/index.jsp?topic=%2Fug\\_nrf91\\_dk%2FUG%2Fnrf91\\_DK%2Fintro.html&cp=2\\_0\\_2](https://infocenter.nordicsemi.com/index.jsp?topic=%2Fug_nrf91_dk%2FUG%2Fnrf91_DK%2Fintro.html&cp=2_0_2)

Block diagram of nRF9160 is shown below.

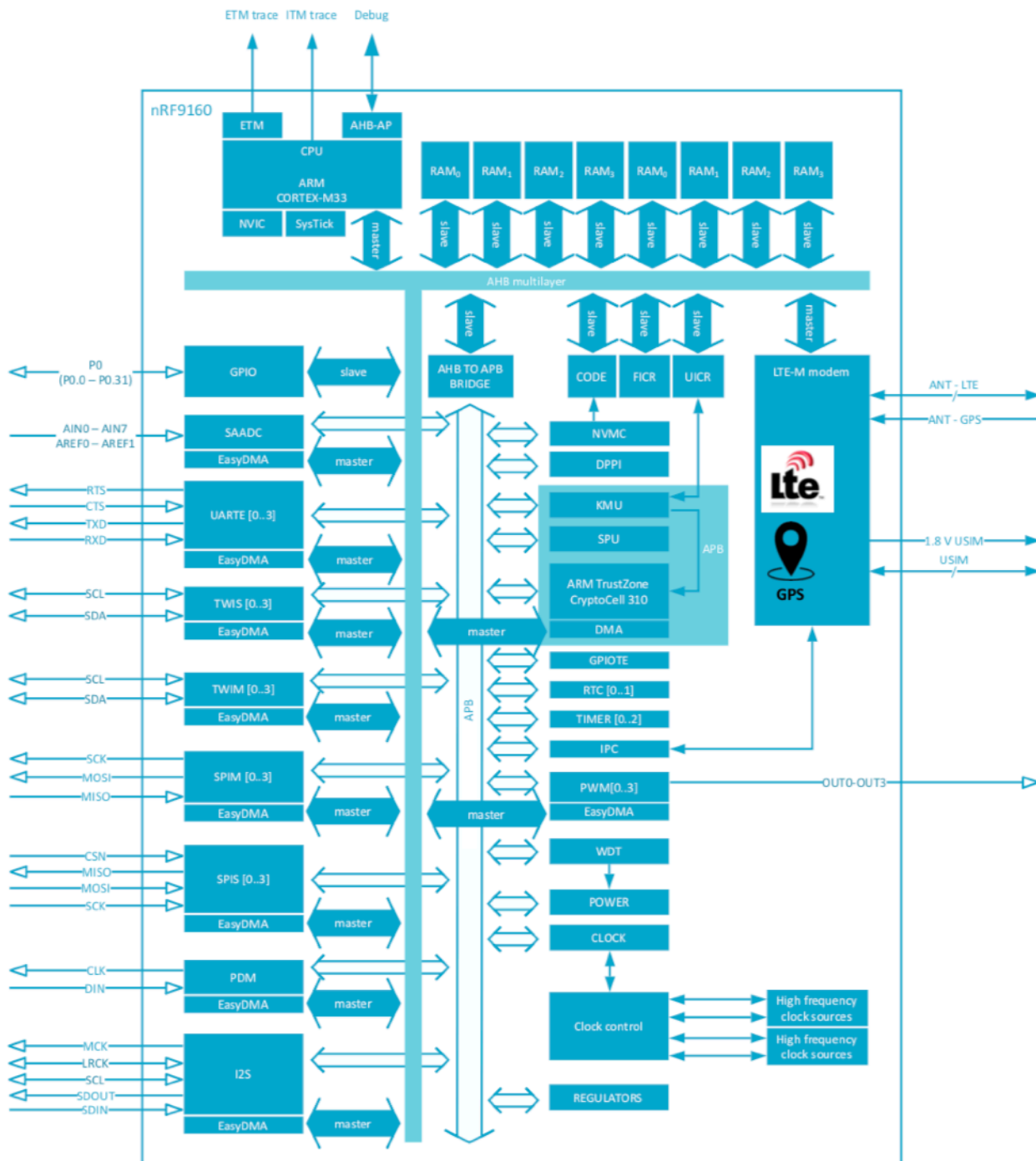

# LTE-BLE 5.1/5.2, 802.15.4 Modules, M.2 Connector Draft Ver 0.61 Aug. 2020

## BT840F

BT840F is a long range nRF52840 module. Product Specifications of nRF52840 can be downloaded from.

[https://infocenter.nordicsemi.com/index.jsp?topic=%2Fug\\_nrf91\\_dk%2FUG%2Fnr91\\_DK%2Fintro.html&cp=2\\_0\\_2](https://infocenter.nordicsemi.com/index.jsp?topic=%2Fug_nrf91_dk%2FUG%2Fnr91_DK%2Fintro.html&cp=2_0_2)

The following is a block diagram of Nordic nRF52840 Bluetooth Low Energy (BLE) SoC. Arrows with white heads indicate signals that share physical pins with other signals.

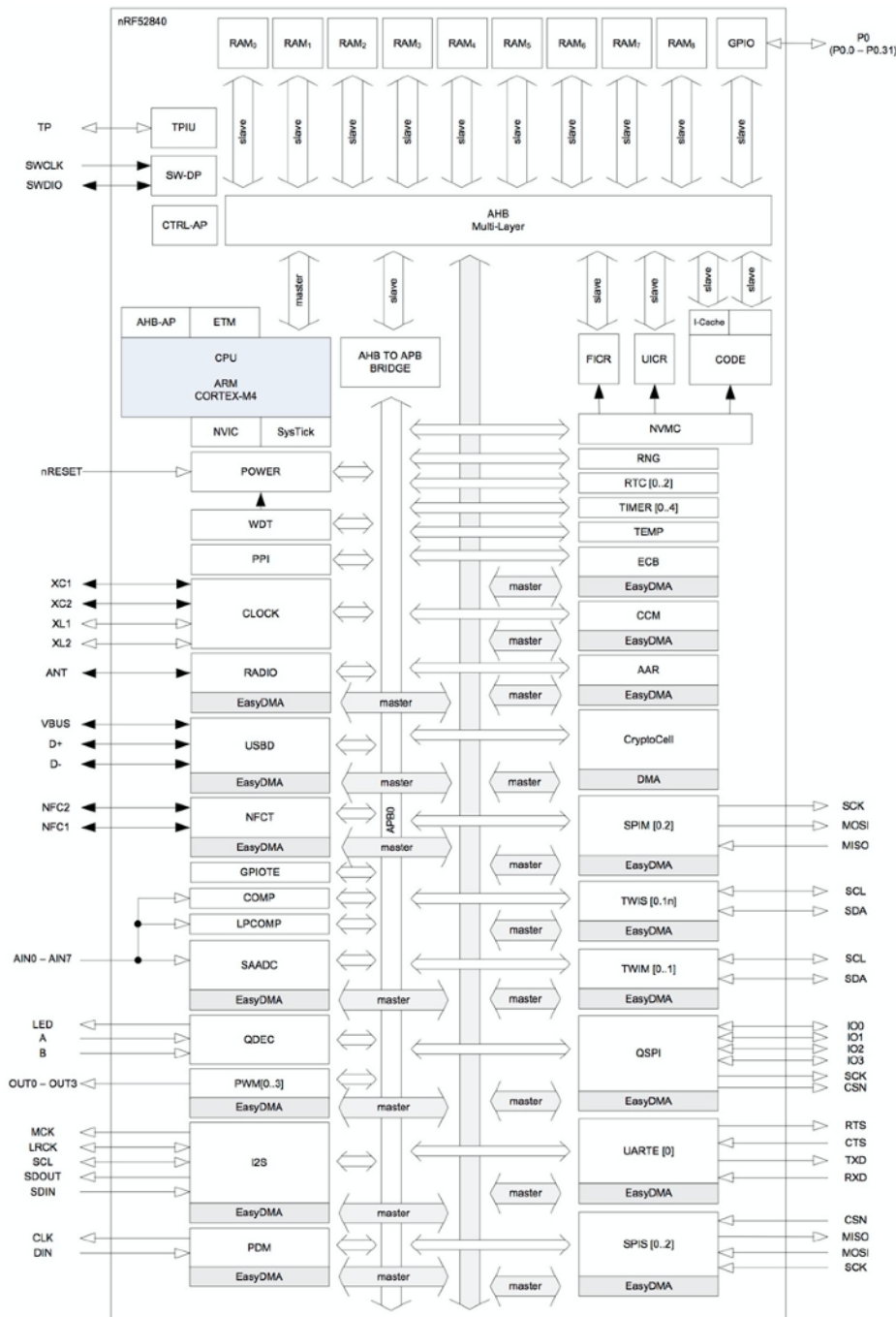



BT840F data sheets can be downloaded from:

<https://www.fanstel.com/download-document>

### BT840X

A Skyworks power amplifier SKY66112 is integrated with nRF52840 in BT840X. A block diagram is shown below. nRf52840 codes to control SKY66112 are included in this data sheets. They can be downloaded from Fanstel webpage.

<https://www.fanstel.com/download-document>

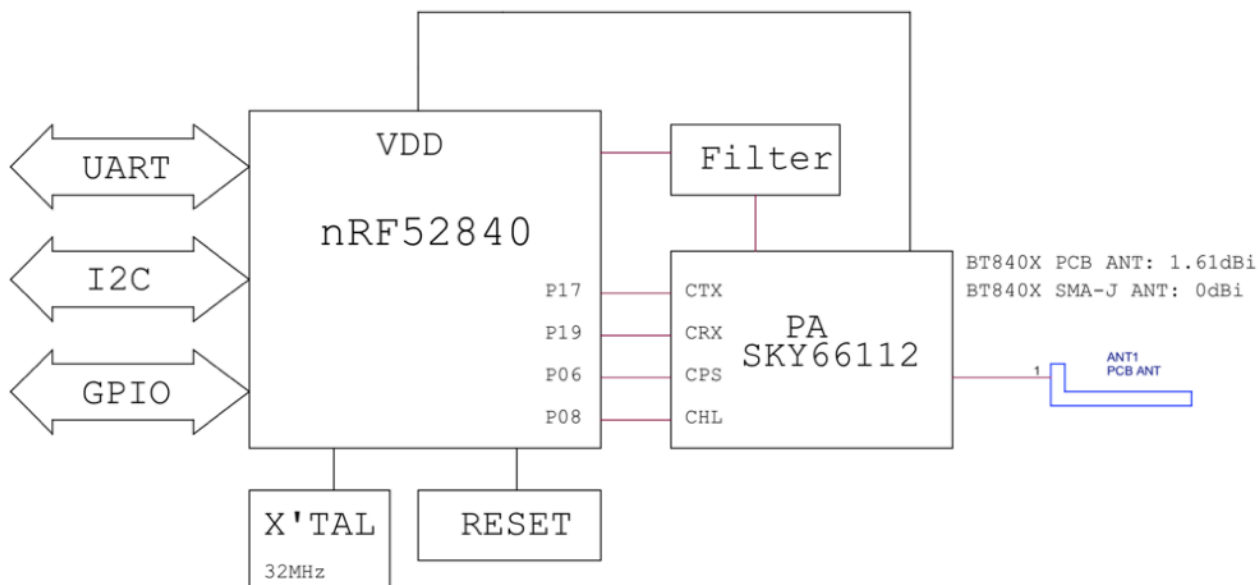

Frequency Band from 2402 MHz to 2480 MHz.

# LTE-BLE 5.1/5.2, 802.15.4 Modules, M.2 Connector Draft Ver 0.61 Aug. 2020

## Mechanical Drawings

Size of LN60E840F is 30x42mm.

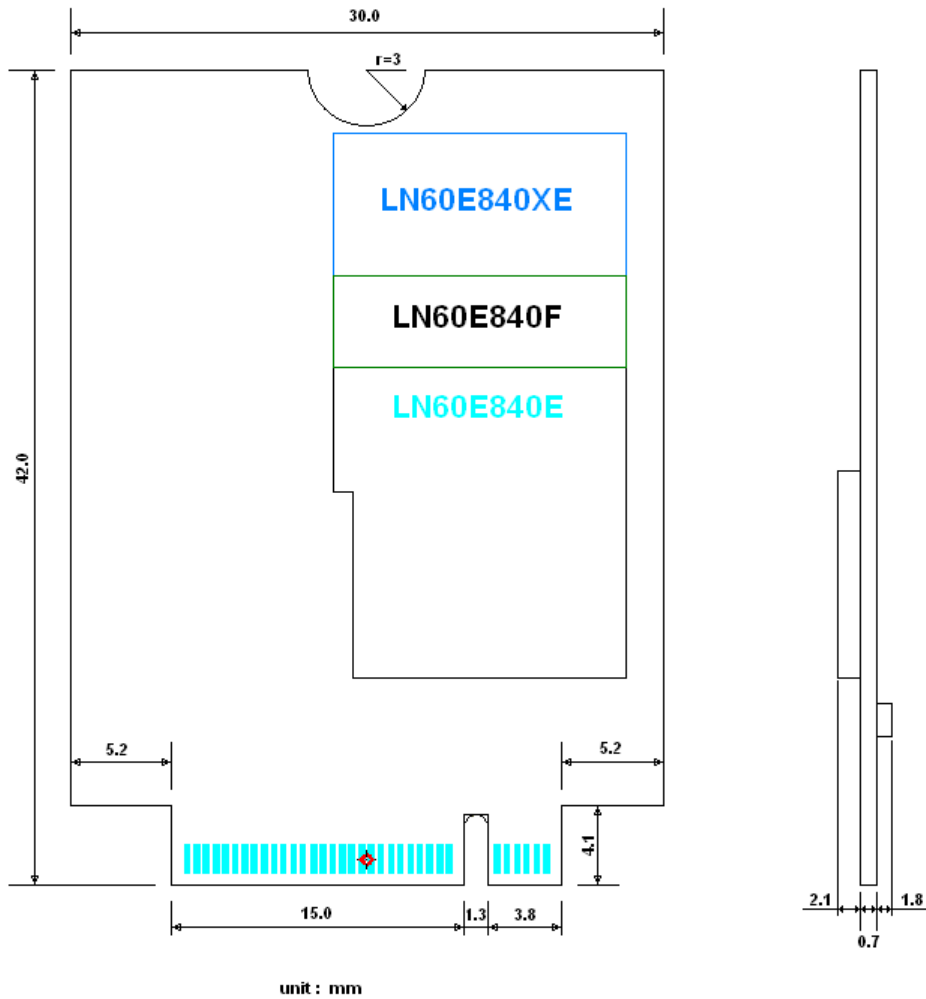

# LTE-BLE 5.1/5.2, 802.15.4 Modules, M.2 Connector Draft Ver 0.61 Aug. 2020

The following is detailed drawing of the M.2 connector.

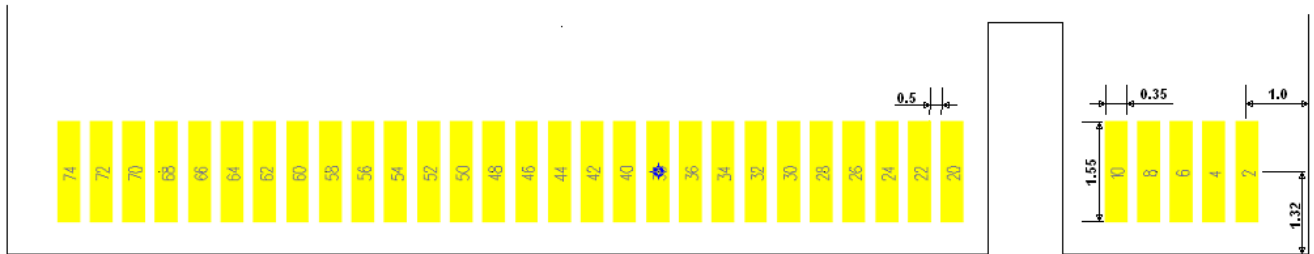
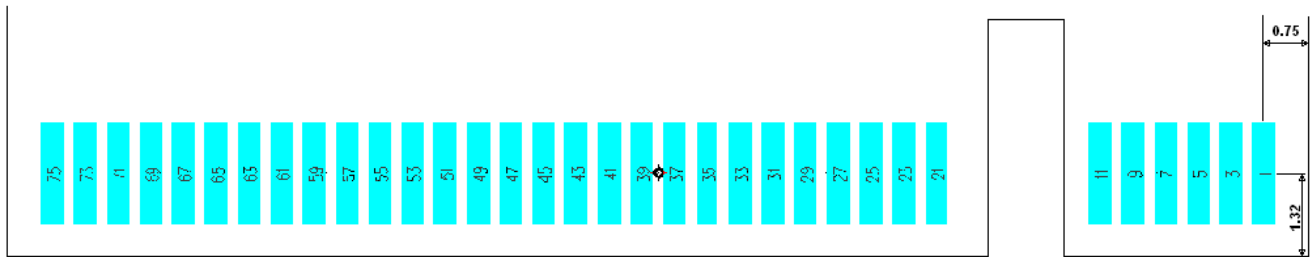

unit: mm

## M.2 Connector Pin Assignments

The followings are LN60E40F M.2 connector pin assignment. Pin functions are in a table in next section. Please refer to Nordic nRF9160, nRF5340, and nRF52840 Product Specifications for detailed descriptions and features supported. Pin names begin with BLE are Bluetooth module pins.

If you are working on a design accommodating both nRF52840 and nRF5340 modules,

- Blue color port names inside the rectangular are for nRF52840 modules.
- Green color port names outside the rectangular are for nRF5340 modules.
- Red color port names outside the rectangular are for nRF9160 module.

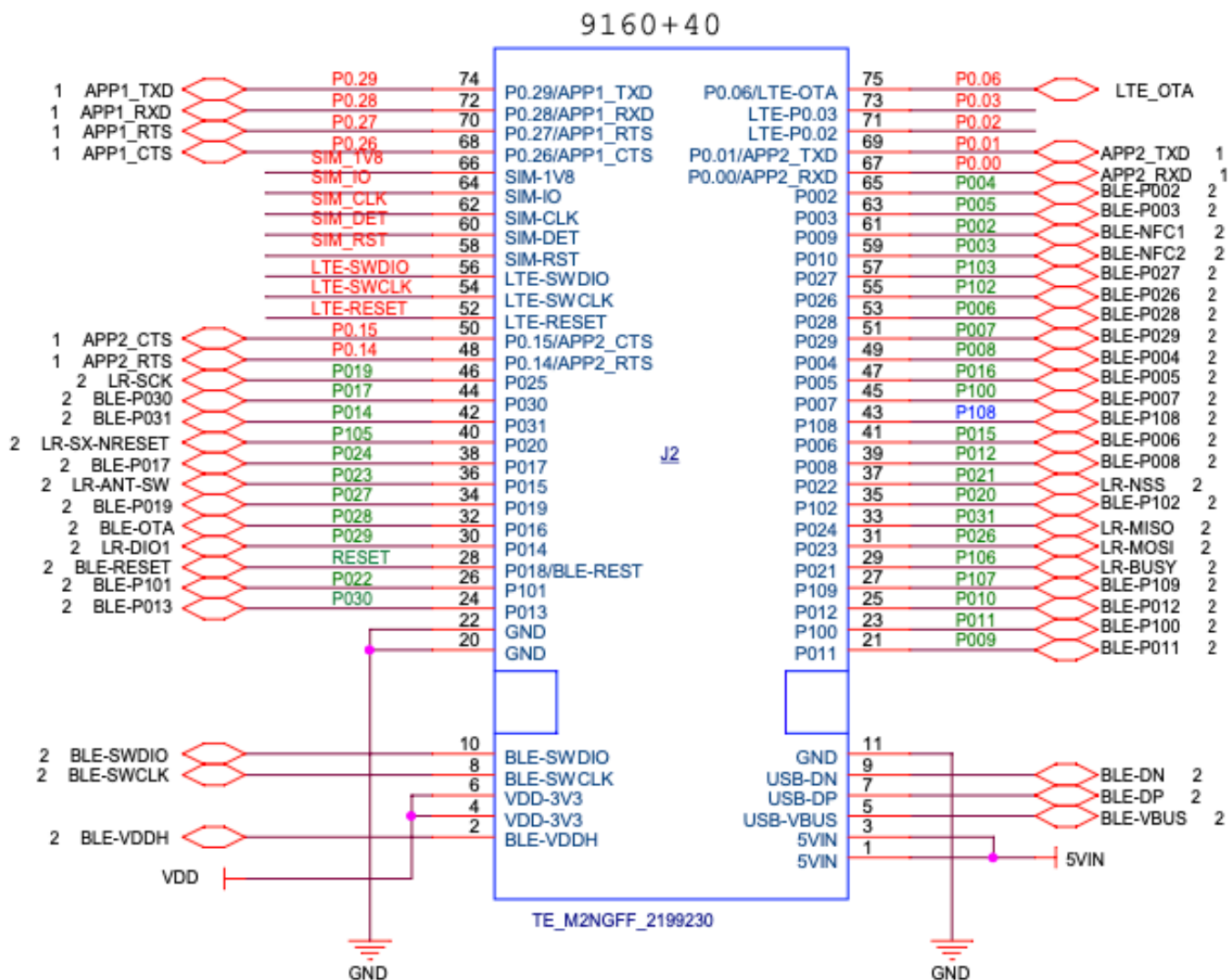

# LTE-BLE 5.1/5.2, 802.15.4 Modules, M.2 Connector Draft Ver 0.61 Aug. 2020

Pin assignments with nRF52840 module.

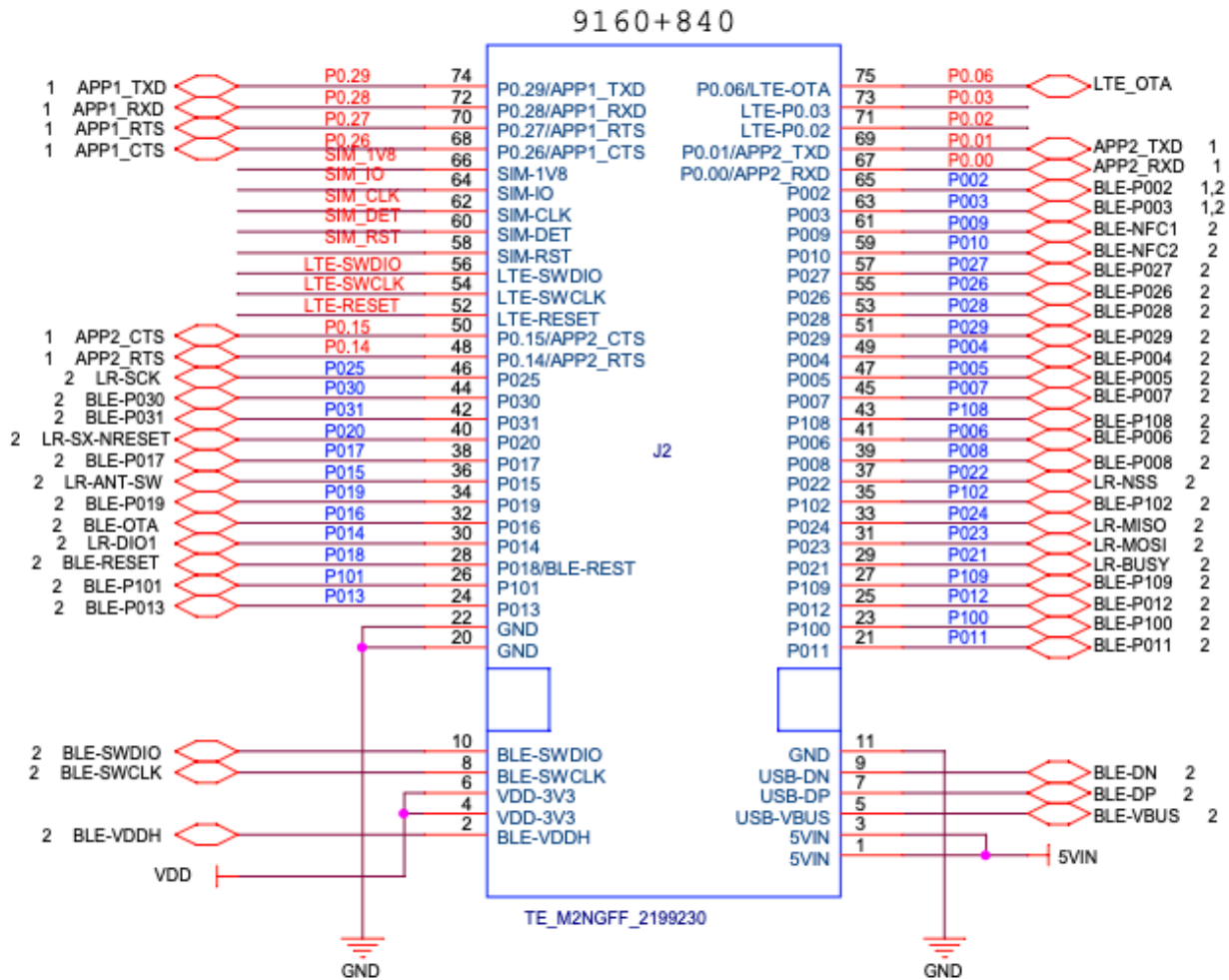

# LTE-BLE 5.1/5.2, 802.15.4 Modules, M.2 Connector Draft Ver 0.61 Aug. 2020

## Pin Function

M.2	9160	BT840F	BT840F/9160	BT40F	BT40F/9160	
pin#	pin#	pin#	Name	pin#	Name	Descriptions
1					5V IN	DC input for 3.3V regulator; 3.2V to 15V. 4.35V minimum if connected to USB-VBUS externally.
2		F4	BLE-VDDH	F4	BLE-VDDH	High voltage input for nRF52840/nRF5340, 2.5V to 5.5V
3					5V IN	DC input for 3.3V regulator; 3.2V to 15V. 4.35V minimum if connected to USB-VBUS externally.
4		9	VDD-3V3	9	VDD-3V3	Regulated 3.3V DC input, 800 mA minimum
5		F6	USB-VBUS	F6	USB-VBUS	USB power supply, 4.35V to 5.5V.
6		9	VDD-3V3	9	VDD-3V3	Regulated 3.3V DC input, 800 mA minimum
7		E4	USB DP	E4	USB DP	USB data pin
8		15	BLE-SWDCLK	15	BLE-SWDCLK	Serial Wire Debug clock input for BLE
9		E5	USB DN	E5	USB DN	USB data pin
10		16	BLE-SWDIO	16	BLE-SWDIO	Serial Wire Debug data for BLE
11		10	GND	10	GND	Ground
12						
13						
14						
15						
16						
17						
18						
19						
20			GND		GND	Ground
21		11	P011	11	P009	BLE GPIO
22			GND		GND	Ground
23		12	P100	12	P011	BLE GPIO
24		13	P013	13	P030	BLE GPIO
25		E6	P012	E6	P010	BLE GPIO
26		D5	P101	D5	P022	BLE_UART RXD
27		E3	P109	E3	P107	BLE GPIO
28		14	P018/RESET	14	RESET	Reset for BT40F, Reset or P018 for BT840F
29		E2	P021	E2	P106	BLE GPIO
30		D4	P014	D4	P029	BLE GPIO
31		D1	P023	D1	P026	BLE GPIO
32		D3	P016	D3	P028	BLE-OTA
33		C1	P024	C1	P031	BLE GPIO
34		D2	P019	D2	P027	BLE GPIO
35		C5	P102	C5	P020	BLE_UART-TXD
36		C4	P015	C4	P023	BLE GPIO
37		C2	P022	C2	P021	BLE GPIO
38		C3	P017	C3	P024	BLE GPIO
39		B5	P008	B5	P012	BLE GPIO
40		E1	P020	E1	P105	BLE GPIO
41		B4	P006	B4	P015	BLE GPIO

# LTE-BLE 5.1/5.2, 802.15.4 Modules, M.2 Connector Draft Ver 0.61 Aug. 2020

42		B3	P031	B3	P014	BLE GPIO
43		A6	P108	A6	P108	BLE GPIO
44		B2	P030	B2	P017	BLE GPIO
45		A5	P007	A5	P100	BLE GPIO
46		B1	P025	B1	P019	BLE GPIO
47		A4	P005	A4	P016	BLE GPIO
48	24		P0.14		P0.14	LTE_UART_APP2-RTS
49		A3	P004	A3	P008	BLE GPIO
50	25		P0.15		P0.15	LTE_UART_APP2-CTS
51		A2	P029	A2	P007	BLE GPIO
52	32		LTE-RESET		LTE-RESET	LTE reset, Active low
53		A1	P028	P006	P006	BLE GPIO
54	33		LTE-SWDCLK		LTE-SWDCLK	LTE-Single Wire Debug clock input
55		1	P026	1	P102	BLE_I2C, SDA
56	34		LTE-SWDIO		LTE-SWDIO	LTE-Single Wire Debug data
57		2	P027	2	P103	BLE_I2C, SCL
58	43		SIM-RESET		SIM-RESET	LTE_SIM reset
59		8	P010	8	P003	BLE_GPIO, NFC2
60	45		SIM-DET		SIM-DET	LTE_SIM detect
61		7	P009	7	P002	BLE_GPIO, NFC1
62	46		SIM-CLK		SIM-CLK	LTE_SIM clock
63		6	P003	6	P005	BLE_GPIO, AIN1
64	48		SIM-IO		SIM-IO	LTE_SIM data
65		5	P002	5	P004	BLE_GPIO, AIN 0
66	47		SIM-1V8		SIM-1V8	LTE_SIM 1.8V power supply
67	95		P0.00		P0.00	LTE_UART_APP2-RXD
68	83		P0.26		P0.26	LTE_UART_APP1-CTS
69	96		P0.01		P0.01	LTE_UART_APP2_TXD
70	84		P0.27		P0.27	LTE_UART_APP1-RTS
71	97		P0.02		P0.02	LTE-GPIO
72	86		P0.28		P0.28	LTE_UART_APP1-RXD
73	99		P0.03		P0.03	LTE-GPIO
74	87		P0.29		P0.29	LTE_UART_APP1-TXD
75	3		P0.06		P0.06	LTE-OTA

### 3. Codes Development Using Nordic Tools

Development tools by Nordic and other third party development tools recommended by Nordic should be used.

Nordic development environment for nRF52840 offers a clean separation between application code development and embedded protocol stacks. This means compile, link and run time dependencies with the embedded stack and associated debugging challenges are removed. The Bluetooth low energy and ANT stack is a pre-compiled binary, leaving application code to be compiled stand-alone. The embedded stack interface uses an asynchronous and event driven model removing the need for RTOS frameworks.

#### Over-The-Air DFU

The nRF52840 is supported by an Over-The-Air Device Firmware Upgrade (OTA DFU) feature. This allows for in the field updates of application software and SoftDevice.

#### SoftDevices

The Nordic protocol stacks are known as SoftDevices and complement the nRF52 Series SoCs. All nRF52 Series are programmable with software stacks from Nordic. This bring maximum flexibility to application development and allows the latest stack version to be programmed into the SoC.

SoftDevices available from Nordic:

**S140:** Bluetooth low energy concurrent central/peripheral/observer/broadcaster stack.

#### Development Tools

Nordic Semiconductor provides a complete range of hardware and software development tools for the nRF52 Series devices. nRF52 DK board is recommended for firmware development.

Nordic software development tools can be downloaded from the following webpage.

[http://infocenter.nordicsemi.com/index.jsp?topic=/com.nordic.infocenter.nrf52/dita/nrf52/development/nrf52\\_dev\\_kit.html&cp=1\\_1](http://infocenter.nordicsemi.com/index.jsp?topic=/com.nordic.infocenter.nrf52/dita/nrf52/development/nrf52_dev_kit.html&cp=1_1)



## Control nRF21540 in BT40X

To be provided.

## Control Skyworks Power Amplifier in BT840X

BT840X in LN60E840X uses SKYWORKS SKY66112-11 power amplifier.

A firmware example to control Skyworks SKY66112 power amplifier is below. This firmware file can be downloaded from <http://www.fanstel.com/download-document/>.

Settings for BT840F and BT840E:

- nRF52840 SoC TX power is set to +8dBm for FCC, ISED, CE, RCM, and TELEC certification testings.
- BT840E passes FCC and ISED certification testings with ANT060, a 6 dBi antenna.
- BT840E passes CE, RCM, and TELEC certification testings with ANT000 antenna.
- VDD is set to 3.3V with DCDC converter enabled.

Settings for BT840X and BT840XE:

- nRF52840 SoC TX is set to +2dBm for FCC and ISED testings.
- nRF52840 SoC TX is set to -4 dBm for CE and RCM testings.
- BT840XE passes FCC, ISED, CE, and RCM certification testings with ANT000, a 0dBi antenna.
- VDD is set to 3.3V.

Firmware to control SKY66112 power amplifier.

### Header files

```
#ifndef PA_LNA_H__  
#define PA_LNA_H__
```

```
#include "ble.h"  
#include "app_error.h"  
#include "nrf_drv_gpiote.h"  
#include "nrf_drv_ppi.h"
```

```
void pa_lna_init(uint32_t gpio_pa_pin, uint32_t gpio_lna_pin);
```

```
#endif
```

### Main program.

```
#include "pa_lna.h"
```

```
#define APP_PA_LAN
```

```
#ifdef APP_PA_LAN
```

```
#define APP_PA_PIN    17
#define APP_LNA_PIN   19
#define APP_CHL_PIN8
#define APP_CPS_PIN   6

int main(void)
{
....
#ifdef APP_PA_LAN
    nrf_gpio_cfg_output(APP_CPS_PIN);
    nrf_gpio_cfg_output(APP_CHL_PIN);
    nrf_gpio_pin_set(APP_CHL_PIN);
    nrf_gpio_pin_clear(APP_CPS_PIN); //enable
    pa_lna_init(APP_PA_PIN,APP_LNA_PIN);
#endif
....
}
```

### **SKY66112 control codes.**

```
#include <stdint.h>
#include <string.h>

#include "pa_lna.h"
#include "ble.h"
#include "app_error.h"
#include "nrf_drv_gpiote.h"
#include "nrf_drv_ppi.h"

void pa_lna_init(uint32_t gpio_pa_pin, uint32_t gpio_lna_pin)
{
    ble_opt_t opt;
    uint32_t gpiote_ch = NULL;
    ret_code_t err_code;

    memset(&opt, 0, sizeof(ble_opt_t));

    err_code = nrf_drv_gpiote_init();
    if(err_code != NRF_ERROR_INVALID_STATE)
        APP_ERROR_CHECK(err_code);

    err_code = nrf_drv_ppi_init();
```

```
//if(err_code != MODULE_ALREADY_INITIALIZED)
    APP_ERROR_CHECK(err_code);

nrf_ppi_channel_t ppi_set_ch;
nrf_ppi_channel_t ppi_clr_ch;

err_code = nrf_drv_ppi_channel_alloc(&ppi_set_ch);
APP_ERROR_CHECK(err_code);

err_code = nrf_drv_ppi_channel_alloc(&ppi_clr_ch);
APP_ERROR_CHECK(err_code);

nrf_drv_gpiote_out_config_t config = GPIOTE_CONFIG_OUT_TASK_TOGGLE(false);

if((gpio_pa_pin == NULL) && (gpio_lna_pin == NULL))
{
    err_code = NRF_ERROR_INVALID_PARAM;
    APP_ERROR_CHECK(err_code);
}

if(gpio_pa_pin != NULL)
{
    if(gpiote_ch == NULL)
    {
        err_code = nrf_drv_gpiote_out_init(gpio_pa_pin, &config);
        APP_ERROR_CHECK(err_code);

        gpiote_ch = nrf_drv_gpiote_out_task_addr_get(gpio_pa_pin);
    }

    // PA config
    opt.common_opt.pa_lna.pa_cfg.active_high = 1; // Set the pin to be active high
    opt.common_opt.pa_lna.pa_cfg.enable     = 1; // Enable toggling
    opt.common_opt.pa_lna.pa_cfg.gpio_pin   = gpio_pa_pin; // The GPIO pin to toggle tx
}

if(gpio_lna_pin != NULL)
{
    if(gpiote_ch == NULL)
    {
        err_code = nrf_drv_gpiote_out_init(gpio_lna_pin, &config);
        APP_ERROR_CHECK(err_code);

        gpiote_ch = nrf_drv_gpiote_out_task_addr_get(gpio_lna_pin);
    }

    // LNA config
    opt.common_opt.pa_lna.lna_cfg.active_high = 1; // Set the pin to be active high
    opt.common_opt.pa_lna.lna_cfg.enable     = 1; // Enable toggling
    opt.common_opt.pa_lna.lna_cfg.gpio_pin   = gpio_lna_pin; // The GPIO pin to toggle rx
}
```

## LTE-BLE 5.1/5.2, 802.15.4 Modules, M.2 Connector Draft Ver 0.61 Aug. 2020

---

```
// Common PA/LNA config
opt.common_opt.pa_lna.gpiote_ch_id = (gpiote_ch - NRF_GPIOTE_BASE) >> 2; // GPIOTE channel used for
radio pin toggling
opt.common_opt.pa_lna.ppi_ch_id_clr = ppi_clr_ch; // PPI channel used for radio pin clearing
opt.common_opt.pa_lna.ppi_ch_id_set = ppi_set_ch; // PPI channel used for radio pin setting

err_code = sd_ble_opt_set(BLE_COMMON_OPT_PA_LNA, &opt);
APP_ERROR_CHECK(err_code);
}
```

## 4. Application Examples

### BLE to LTE Gateway

In this basic BLE 5/802.15.4 to LTE-NB-IoT gateway design:

- The bold, gray rectangular box is the boundary of M.2 connector, B Key.
- Most of free GPIOs on M.2 connector are from BLE module.
- nRF9160 is connected to BT840F/BT40F through host board using UART.
- Optional flash memory can be installed for BLE module without SKY66112 power amplifier. QSPI pins are used for PA control inside BT840X/XE.
- Nano SIM connector is on LT60E module. eSIM interface is available on M.2 connector to install eSIM on host board.

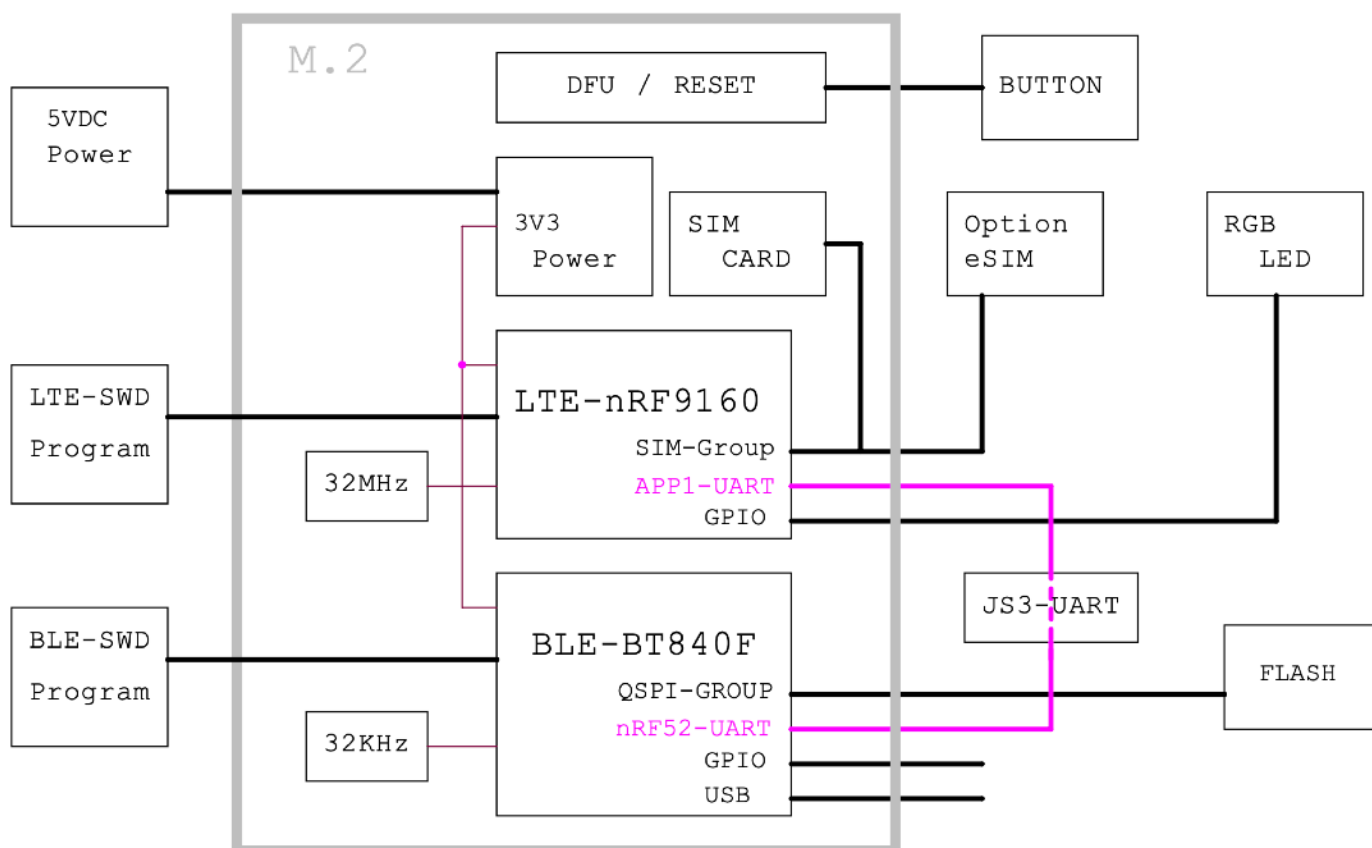

# LTE-BLE 5.1/5.2, 802.15.4 Modules, M.2 Connector Draft Ver 0.61 Aug. 2020

## BLE-LoRa to LTE, WiFi, PoE Ethernet Gateway

This application example supports multiple network interfaces and multiple protocols.

- PoE Ethernet and 802.11 b/g/n WiFi circuitry is on gateway host board.
- M.2 connectors for LTE/NB-IoT network expansion and to support Bluetooth, Thread, Zigbee, LoRa device interfaces.
- Data from sensors and other devices can be processed in the host board MCU (ESP32) before sending to cloud server.
- Host board with more powerful MCU for Edge Computing available in 2021.

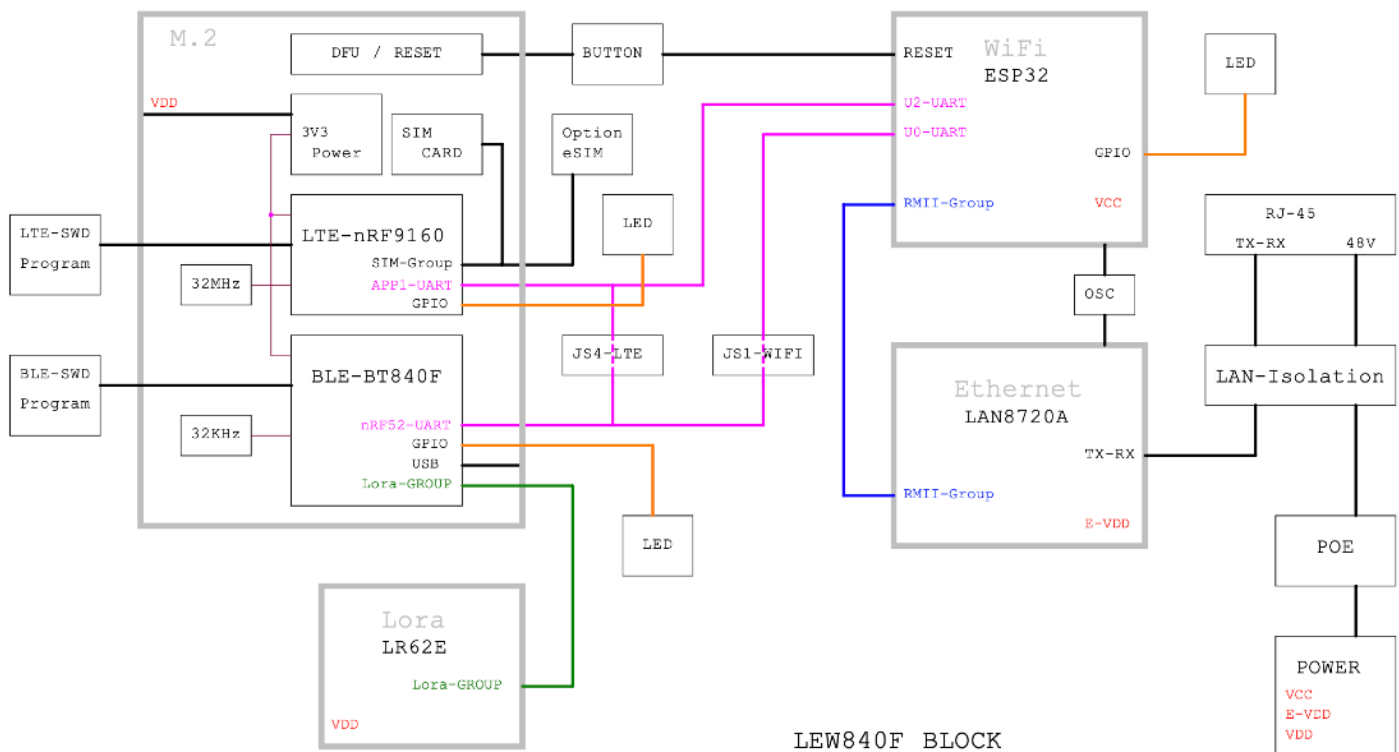

## **5. EV-BLN60E40F Evaluation Board**

An evaluation board consists of the followings:

- Micro USB cable
- Evaluation board
- 10-conductor cable for connection to Nordic nRF52 DK (DK is not included)
- AC adapter
- External LTE antenna

## Nordic Development Tools

A Nordic nRF52 DK is recommended for programming this evaluation board. Nordic development tools can be downloaded from:

<https://www.nordicsemi.com/eng/Products/nRF52840>

Many application examples can be downloaded from Nordic website.

Some firmware, Android OS, and iOS app codes can be downloaded from **Bluetooth 5 Codes section** of this Fanstel webpage.

<http://www.fanstel.com/download-document/>

**BT840** firmware can be used in all nRF52840 modules, e.g., BT840, BT840F, and BT840E.

## Android OS Apps

The following Android OS apps are available for download from Google Play Store:

**BlueNor nrf5x**: to use with Bluetooth 5 stacks, AT commands, or Slave firmware. Master firmware does not connect to a smartphone. Source codes can be downloaded from <http://www.fanstel.com/download-document/>

**BlueNor Mesh**: to use with BlueNor mesh firmware to send command to any node in a mesh. Node number is displayed when acknowledgement is received. Source codes will be uploaded to Fanstel website when supporting Bluetooth 5.

## iOS Apps

The following iOS apps can be downloaded from Apple APP Store.

**BlueNor Mesh**: to use with BlueNor mesh firmware to send command to any node in a mesh. Node number is displayed when acknowledgement is received.

**BlueNor nrf5x** firmware, apps, and source codes will be uploaded when ready.



## LN60E40F EvaluationBoard Schematics

Evaluation board schematics and Gerber files can be downloaded from

<http://www.fanstel.com/download-document/>

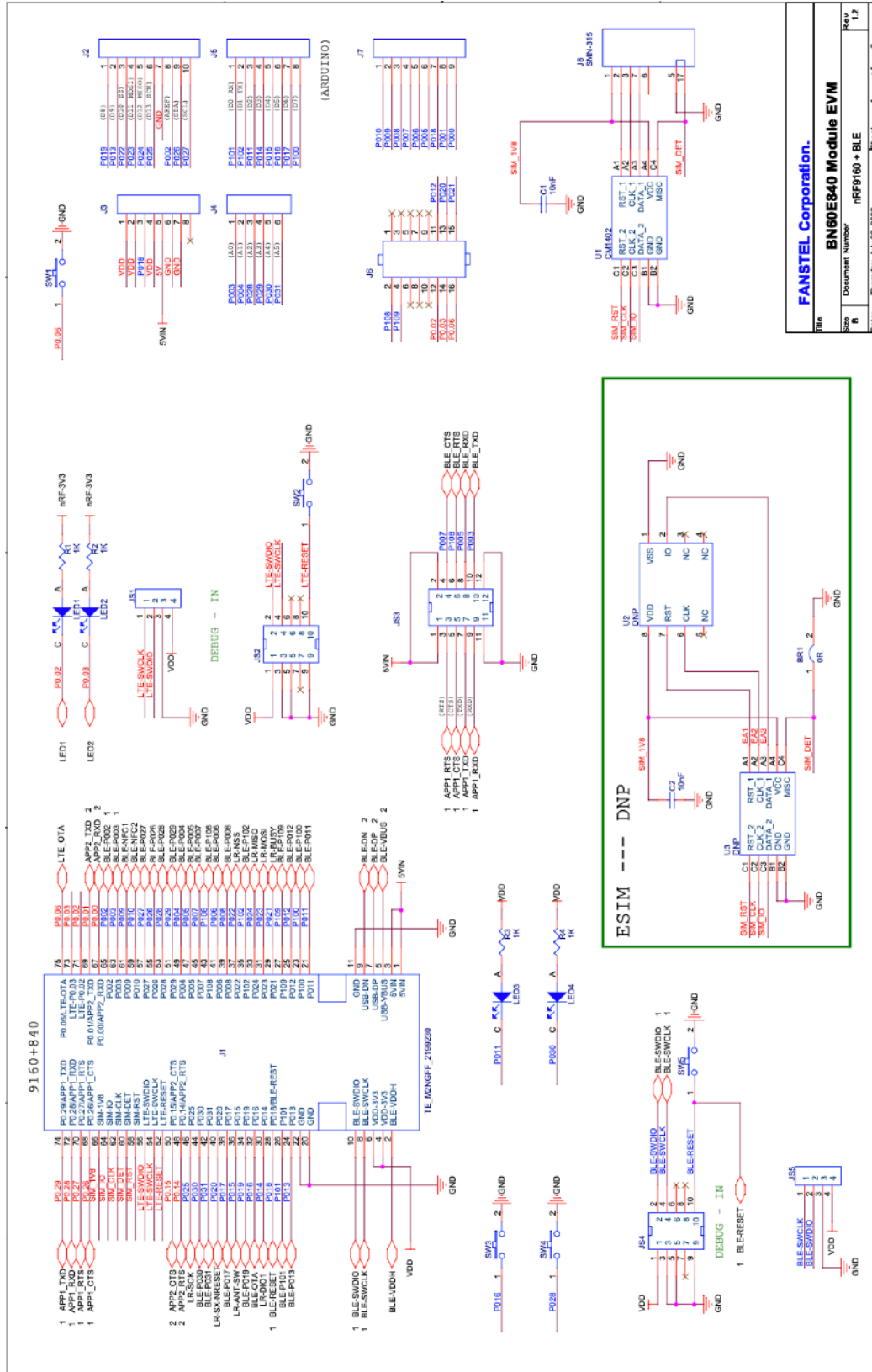

<b>FANSTEL Corporation.</b>					
File	<b>BN60E840 Module EVM</b>		Rev	1.2	
Doc	Document Number	rRF9160 + BLE			
Site	Thurgau, July 06, 2020			Sheet	1 of 2

# LTE-BLE 5.1/5.2, 802.15.4 Modules, M.2 Connector Draft Ver 0.61 Aug. 2020

Page 2 of EV-LN60E schematics. EV board schematics can be used as a reference design for using modules.

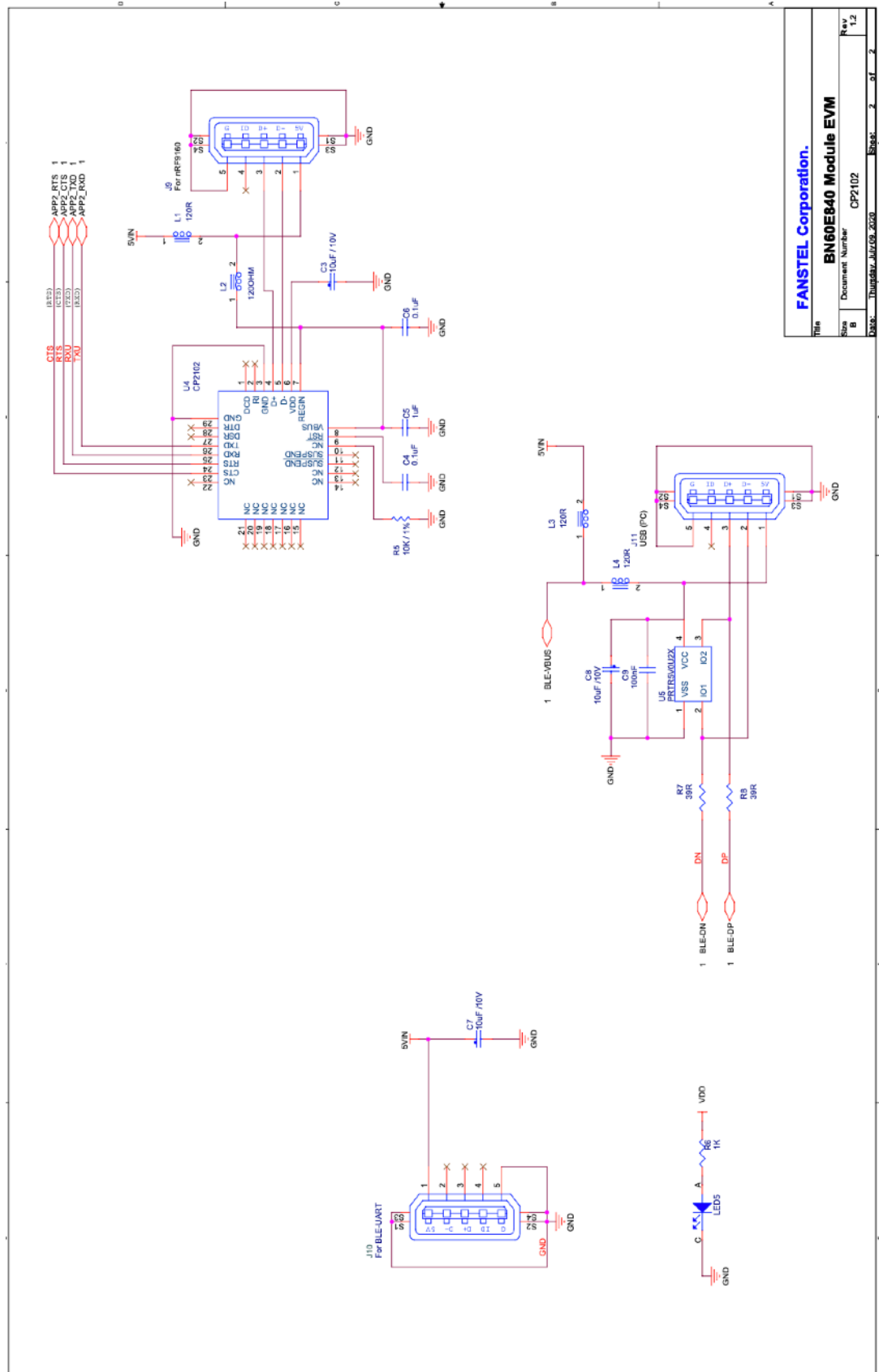

## 6. Miscellaneous

### Cautions, Design Notes, and Installation Notes

Failure to follow the guidelines set forth in this document may result in degrading of the product's functions and damage to the product.

#### *Design Notes*

- (1) Follow the conditions written in this specification, especially the control signals of this module.
- (2) The supply voltage has to be free of AC ripple voltage (for example from a battery or a low noise regulator output). For noisy supply voltages, provide a decoupling circuit (for example a ferrite in series connection and a bypass capacitor to ground of at least 47uF directly at the module).
- (3) This product should not be mechanically stressed when installed.
- (4) Keep this product away from heat. Heat is the major cause of decreasing the life of these products.
- (5) Avoid assembly and use of the target equipment in conditions where the products' temperature may exceed the maximum tolerance.
- (6) The supply voltage should not be exceedingly high or reversed. It should not carry noise and/or spikes.
- (7) this product away from other high frequency circuits.

#### *Notes on Antenna and PCB Layout*

- (1) Don't use a module with internal antenna inside a metal case.
- (2) For PCB layout:
  - Avoid running any signal line below module whenever possible,
  - No ground plane below antenna,
  - If possible, cut-off the portion of main board PCB below antenna.

#### *Installation Notes*

- (1) Reflow soldering is possible twice based on the time-temperature profile in this data sheets. Set up the temperature at the soldering portion of this product according to this reflow profile.
- (2) Carefully position the products so that their heat will not burn into printed circuit boards or affect the other components that are susceptible to heat.
- (3) Carefully locate these products so that their temperatures will not increase due to the effects of heat generated by neighboring components.
- (4) If a vinyl-covered wire comes into contact with the products, then the cover will melt and generate toxic gas, damaging the insulation. Never allow contact between the cover and these products to occur.
- (5) This product should not be mechanically stressed or vibrated when reflowed.
- (6) If you want to repair your board by hand soldering, please keep the conditions of this chapter.

- (7) Do not wash this product.
- (8) Refer to the recommended pattern when designing a board.
- (9) Pressing on parts of the metal cover or fastening objects to the metal will cause damage to the unit.

#### **Usage Condition Notes**

- (1) Take measures to protect the unit against static electricity. If pulses or other transient loads (a large load applied in a short time) are applied to the products, check and evaluate their operation before assembly on the final products.
- (2) Do not use dropped products.
- (3) Do not touch, damage or soil the pins.
- (4) Follow the recommended condition ratings about the power supply applied to this product.
- (5) Electrode peeling strength: Do not add pressure of more than 4.9N when soldered on PCB
- (6) Pressing on parts of the metal cover or fastening objects to the metal cover will cause damage.
- (7) These products are intended for general purpose and standard use in general electronic equipment, such as home appliances, office equipment, information and communication equipment.

#### **Storage Notes**

- (1) The module should not be stressed mechanically during storage.
- (2) Do not store these products in the following conditions or the performance characteristics of the product, such as RF performance will be adversely affected:
  - Storage in salty air or in an environment with a high concentration of corrosive gas.
  - Storage in direct sunlight
  - Storage in an environment where the temperature may be outside the range specified.
  - Storage of the products for more than one year after the date of delivery storage period.
- (3) Keep this product away from water, poisonous gas and corrosive gas.
- (4) This product should not be stressed or shocked when transported.
- (5) Follow the specification when stacking packed crates (max. 10).

#### **Safety Conditions**

These specifications are intended to preserve the quality assurance of products and individual components. Before use, check and evaluate the operation when mounted on your products. Abide by these specifications, without deviation when using the products. These products may short-circuit. If electrical shocks, smoke, fire, and/or accidents involving human life are anticipated when a short circuit occurs, then provide the following failsafe functions, as a minimum.

- (1) Ensure the safety of the whole system by installing a protection circuit and a protection device.

(2) Ensure the safety of the whole system by installing a redundant circuit or another system to prevent a dual fault causing an unsafe status.

#### **Other Cautions**

(1) This specification sheet is copyrighted. Reproduction of this data sheet is permissible only if reproduction is without alteration and is accompanied by all associated warranties, conditions, limitations, and notices.

(2) Do not use the products for other purposes than those listed.

(3) Be sure to provide an appropriate failsafe function on your product to prevent an additional damage that may be caused by the abnormal function or the failure of the product.

(4) This product has been manufactured without any ozone chemical controlled under the Montreal Protocol.

(5) These products are not intended for other uses, other than under the special conditions shown below. Before using these products under such special conditions, check their performance and reliability under the said special conditions carefully to determine whether or not they can be used in such a manner.

- In liquid, such as water, salt water, oil, alkali, or organic solvent, or in places where liquid may splash.
- In direct sunlight, outdoors, or in a dusty environment
- In an environment where condensation occurs.
- In an environment with a high concentration of harmful gas.











(6) If an abnormal voltage is applied due to a problem occurring in other components or circuits, replace these products with new products because they may not be able to provide normal performance even if their electronic characteristics and appearances appear satisfactory.

(7) When you have any question or uncertainty, contact Fanstel.

### Packaging and Lot Number

Production modules are delivered in reel, 1000 modules in each reel. Lot number for modules made after May 2019, can be used to track silicon version of SoC, module PCB version, and production test code version.



<p>(K) Cust. PO:2630427  </p> <p>(4K) Cust. PO line:00003  </p> <p>(P) Cust. P/N : 1914-1019-2-ND  </p> <p>(1T) Lot :D0V218B-0000000  </p> 	<p>(Q) QTY :1000  </p> <p>(1P) MFG P/N : BT840F  </p> <p>(6D) Ship Date :20190522  </p> <p>(9D) Date : 1920  </p> <p>(4L) COO: CN  </p>
---	--

MSL	3/260°C
(E)	e4
<b>RoHS</b>	

### Lot: D0 V2 18B - 00 00 000

D0: 2 digits, version number of SoC.

V2: 2 digits, version number of module PCB.

18B: the first 2 digits for production test codes released year and the last digit for month in hex format. A=October, B=November, C=December. 18B was released in November 2018.

00 00 000, 7 digits, reserved for 2nd SoC for modules with 2 SoCs.

### FCC LABEL

The Original Equipment Manufacturer (OEM) must ensure that the OEM modular transmitter must be labeled with its own FCC ID number. This includes a clearly visible label on the outside of the final product enclosure that displays the contents shown below. If the FCC ID is not visible when the equipment is installed inside another device, then the outside of the device into which the equipment is installed must also display a label referring to the enclosed equipment

The end product with this module may subject to perform FCC part 15 unintentional emission test requirement and be properly authorized.

This device is intended for OEM integrator only.

## Revision History

- Aug. 2020, Ver. 0.60: Initial draft release

## Contact Us

### United States:

Fanstel Corp.

7466 E. Monte Cristo Ave. Scottsdale AZ 85260

Tel. 1 480-948-4928

Fax. 1-480-948-5459

Email: [info@fanstel.com](mailto:info@fanstel.com)

Website: [www.fanstel.com](http://www.fanstel.com)

### Taiwan:

Fanstel Corp.

10F-10, 79 Xintai Wu Road

Xizhu, New Taipei City, Taiwan 22101

泛世公司

臺灣省新北市汐止區新臺五路79號10樓之10, 22101

Tel. 886-2-2698-9328

Fax. 886-2-2698-4813

Email: [info@fanstel.com](mailto:info@fanstel.com)

Website: [www.fanstel.com](http://www.fanstel.com)

### China:

Fanstel Technologies Corp.

11 Jiale Street

Ping-Dih, Long-Gang, Shen Zhen, GD 518117

泛世康科技(深圳)有限公司

廣東省深圳市龍崗區坪地鎮佳樂街11號

Tel. 86-755-8409-0928

Fax. 86-755-8409-0973

QQ. 3076221086

Email: [info@fanstel.com](mailto:info@fanstel.com)

Website: [www.fanstel.com](http://www.fanstel.com)



## X-ON Electronics

Largest Supplier of Electrical and Electronic Components

*Click to view similar products for [Multiprotocol Modules](#) category:*

*Click to view products by [Fanstel](#) manufacturer:*

Other Similar products are found below :

[9260.NGWG.NV 958867](#) [AX210.NGWG.NV](#) [BM833](#) [ESP32-C3-MINI-1U-H4](#) [ESP32-WROOM-32U-16MB](#) [ESP32-WROOM-32UE](#)  
[ESP32-WROOM-32D-H4](#) [ESP32-WROOM-32U-H4](#) [ESP32-PICO-MINI-02U-N8R2](#) [ESP32-C6-WROOM-1-N4](#) [ESP32-C6-WROOM-1U-N4](#)  
[ESP32-C6-WROOM-1-N8](#) [BE200.NGWG.NV](#) [BE200.NGWG](#) [BE202.NGWG.NV](#) [BE200.NGWG.NVX](#) [AX411.NGWG.NV](#) [AX210.D2WG](#)  
[AX210.NGWG.NVX](#) [AX211.NGWG](#) [EC200UEUAA-N05-TA0AA](#) [SC20ELSATEA-8GB-UGAD](#) [SG560DEUPA-U61-TA0AA](#)  
[AX211.NGWG.NV](#) [ISM43340-M4G-L44-10CF-C6.2.1.11](#) [KG100SABMD](#) [BC40P](#) [S007-PIN254](#) [S007-PIN127](#) [ESP32-C3-12F](#)  
[FC41DAHMD](#) [EWM-W179M201E](#) [ESP32-C6-WROOM-1U-N8](#) [ATWILC3000-MR110CA](#) [RS9113-NBZ-D5W](#) [ATWINC3400-](#)  
[MR210UA122](#) [ESP32-WROOM-32](#) [AMPAK AP12356 WIFI/BT KIT](#) [AIW-154BN](#) [AIW-165BN](#) [AIW-166K1](#) [AIW-166K2](#) [AIW-166K3](#)  
[AIW-166K4](#) [AIW-355 DQ-N01](#) [AIW-355 DQ-C01](#) [EWM-W159M201E](#) [EWM-W192K1](#) [EWM-W192K2](#) [W106C](#)