

## Chip Inductors for RF Applications / Medical Applications (Wire wound-open)

FASTRON's wire wound chip inductors are designed for radio frequency (RF) applications that require optimal Q on high frequency circuits. Its gold flash pad metallization provides better solderability for a higher yield in production. Additionally, their encapsulation not only protects the winding but also allows for surface mount assembly. It comes in compact sizes (from 0402 to 1812) and is available in reel packaging. Unlisted inductance values are usually available upon request. Ferrite core versions are also available for selected case sizes for applications which require higher inductances in a smaller case size.

**Applications** Used in LC resonant circuits such as oscillator and signal generators, impedance matching, RF filters etc.  
 Mobile Telecommunication: GSM, CDMA, TCDMA, cordless phones, 2 way radio  
 Automotive Subsystems: TPMS, Keyless Entry, Anti-Theft, GPS  
 Wireless Communication: W-LAN, WIFI, WIMAX, RFID, Bluetooth  
 Non-magnetic versions for medical imaging applications: ASM series

### Technical Data

L – Value (Rated Inductance)	≥ 1 MHz measured with HP 4286A RF LCR meter or equivalent at frequency $f_L$ , 25°C ambient < 1 MHz measured with HP 4285A or equivalent at frequency $f_L$ , 25°C ambient
Q – Factor (min)	≥ 1 MHz measured with E4991B Impedance Analyzer or equivalent at frequency $f_Q$ , 25°C ambient < 1 MHz measured with HP 4285A or equivalent at frequency $f_Q$ , 25°C ambient
SRF (min)	Measured with HP8753ES Network Analyzer or equivalent at 25°C ambient
DCR (max)	Measured at 25°C ambient
Rated DC Current: Irms	Max permissible current that causes a 15°C component temperature rise from 25°C ambient for AS, AQ, ASM & F Max permissible current that causes a 40°C component temperature rise from 25°C ambient for AQC & FLP
Saturation Current: Isat	Max permissible DC bias at 25°C ambient that causes inductivity drop 30% (typ.) related to the unloaded inductivity for FLP.
Operating Temperature	-40°C to +100°C (Including component self-heating): F -40°C to +125°C (Including component self-heating): FLP -40°C to +140°C (Including component self-heating): AS, AQ, ASM & AQC
Surface Finishing	Epoxy molded flat top for perfect pick and place assembly
Pad Metallization	Gold flash as top layer for AS, AQ, F & AF Silver-Palladium-Platinum for ASM & AQC Tin as top layer for FLP
Wire Termination	Spot welding
Recommended Soldering Method	Reflow
Moisture Sensitivity Levels (MSL)	MSL Level 1, indicating unlimited floor life at ≤ 30°C / 85% relative humidity
Solderability	Using lead free solder (Sn 99.9) at 260°C ± 5°C for 5 ± 0.5 seconds, min 90% solder coverage of metallization Standard: IEC 68-2-20 (Ta)
Resistance to Soldering Heat	Resistant to 260°C ± 5°C for 10 ± 1 seconds Standard: IEC 68-2-20 (Tb)
Resistance to Solvent	Resistant to isopropyl alcohol for 5 ± 0.5 minutes at 23°C ± 5°C Standard: IEC 68-2-45
Climatic Test	Defined by the following standards IEC 68-2-1 for Cold test: -55°C for 96 hours IEC 68-2-2 for Dry heat test: +85°C for ferrite core and 125°C for ceramic core for 96 hours IEC 60068-2-78 for Humidity test: 40°C at RH 95% for 4 days
Thermal Shock Test	Temperature cycle (ceramic): -40°C to +125°C to -40°C Temperature cycle (ferrite): -40°C to +85°C to -40°C Max/Min temperature duration: 15 minutes Temperature transition duration: 5 minutes Cycles: 25 Standard: MIL-STD-202G
Adhesion of Soldered Component (Shear Test)	Components withstand a pushing force of 10N for 10 ± 1 seconds Standard: IEC 60068-2-21, method Ue3
Mechanical Shock	Mil-Std 202 Method 213, Condition C 3 axis, 6 times, total 18 shocks 100 G, 6 ms, half-sine
Vibration	Mil-Std 202 Method 204 20 mins at 5G 10 Hz to 2000 Hz 12 cycles each of 3 orientations

## Chip Inductors for RF Applications / Medical Applications (Wire wound-open)

Ordering Code Example : 0402AS-1N0X-YY → **0402AS-1N0K-01**

**0402 AS - 1N0 X - YY**  
(Case Size) (Core Type) (Inductance Value) (Tolerance) (Packaging Code)

Case Sizes - 0402, 0603, 0805, 1008, 1206, 1210, 1812

Core Type - AS, AQ, AQC, ASM (Ceramic), F (Ferrite), AF (Ceramic & Ferrite), FLP (Ferrite Low Profile)

Tolerances - F (1%), G (2%), A (3%), J (5%), K (10%), L (15%), M (20%)

Packaging Code - 01, 04, 08 (Taped / Reel)

### Packaging Specification Schematic

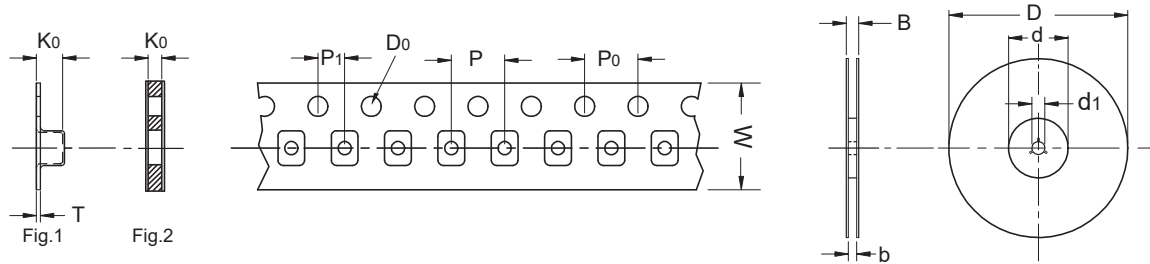

Type	Packaging Code	D	D0	d	d1	B	b	W	P	P0	P1	K0	T	Fig
0402	01,08	180	1.55	60	13	11.9	9.5	8	2	4	2	0.60	-	2
0603	01,08	180	1.55	60	13	11.4	9.0	8	4	4	2	0.98	-	2
0603	04	330	1.55	100	13	14.4	8.4	8	4	4	2	0.98	-	2
0805	01,08	180	1.55	60	13	11.4	9.0	8	4	4	2	1.63	0.25	1
0805	04	330	1.55	100	13	14.4	8.4	8	4	4	2	1.63	0.25	1
1008	01,08	180	1.50	60	13	11.4	9.5	8	4	4	2	2.23	0.30	1
1008	04	330	1.55	100	13	14.4	8.4	8	4	4	2	1.63	0.25	1
1206	01,08	180	1.50	60	13	18.4	13.7	12	4	4	2	1.80	0.30	1
1206	04	330	1.50	100	13	18.4	12.4	12	4	4	2	1.80	0.30	1
1210	01	180	1.55	60	13	18.4	13.7	12	8	4	2	2.55	0.30	1
1210	04	330	1.55	100	13	18.4	12.4	12	8	4	2	2.55	0.30	1
1812	01	180	1.50	60	13	18.4	13.7	12	8	4	2	3.70	0.35	1
1812	04	330	1.50	100	13	18.4	12.4	12	8	4	2	3.70	0.35	1

## FASTRON's Component Key Characteristics



Approved according to AEC-Q200



Approved according to AEC-Q200 with High Temperature



Suitable for High Temperature



Part is RoHS conform and Halogen free



Mechanical Shock and Vibration Proof



Designed for High Q-values



Exceptionally High Q-values



Optimized for High Currents



Optimized for High Voltages

# 0402 AS

Engineer's Kit: EK-0402AS-X

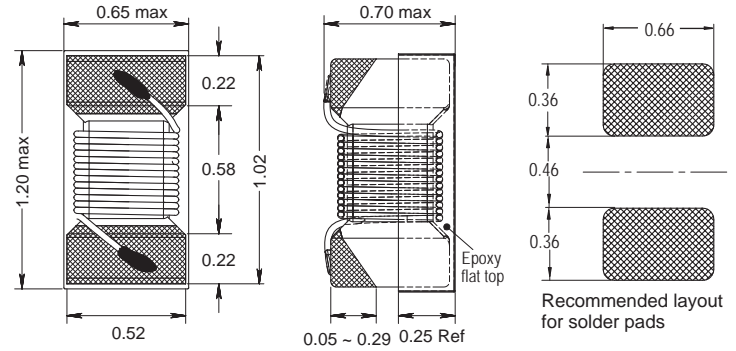
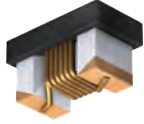

Chip Inductors for RF Applications

(Wire wound - open)

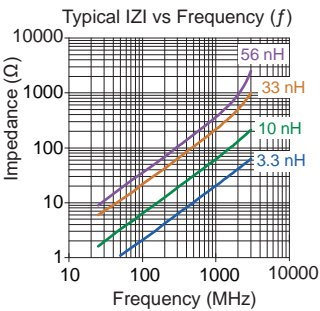
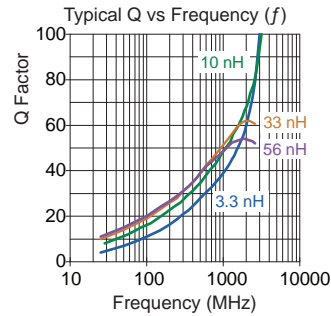
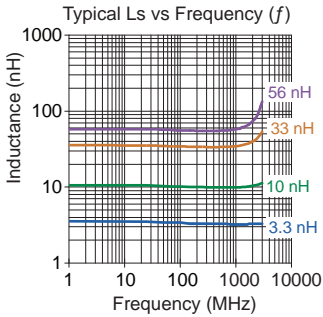

Single layer (typ)

Part No	Inductance	f <sub>L</sub>	Tol	Q	f <sub>α</sub>	SRF	DCR	Rated DC
	L (nH)	(MHz)	± (%)	min	(MHz)	(MHz)	max (Ω)	Current max (mA)
0402AS-0N9K-YY	0.9	250	10	11	250	6000 min	0.04	1360
0402AS-1N0K-YY	1.0	250	10	11	250	6000 min	0.07	700
* 0402AS-1N2K-YY	1.2	250	10	11	250	6000 min	0.11	700
0402AS-1N8K-YY	1.8	250	10	16	250	6000 min	0.07	1040
0402AS-1N9K-YY	1.9	250	10	16	250	6000 min	0.07	1040
0402AS-2N0K-YY	2.0	250	10	16	250	6000 min	0.07	1040
0402AS-2N2K-YY	2.2	250	10	14	250	6000 min	0.11	640
0402AS-2N4K-YY	2.4	250	10	16	250	6000 min	0.12	640
0402AS-2N5K-YY	2.5	250	10	16	250	6000 min	0.12	640
* 0402AS-2N7K-YY	2.7	250	10	16	250	6000 min	0.12	640
* 0402AS-2N9K-YY	2.9	250	10	16	250	6000 min	0.10	700
0402AS-3N3K-YY	3.3	250	10	20	250	6000 min	0.10	700
0402AS-3N6K-YY	3.6	250	10	19	250	6000 min	0.10	700
0402AS-3N9K-YY	3.9	250	10	19	250	4800 min	0.10	700
0402AS-4N3K-YY	4.3	250	10	18	250	6000 min	0.091	700
0402AS-4N7K-YY	4.7	250	10	15	250	4775 min	0.130	640
0402AS-5N1J-YY	5.1	250	5	23	250	4800 min	0.083	800
0402AS-5N6J-YY	5.6	250	5	22	250	4800 min	0.110	760
0402AS-6N2J-YY	6.2	250	5	20	250	4800 min	0.110	760
0402AS-6N8J-YY	6.8	250	5	21	250	4800 min	0.100	680
0402AS-7N5J-YY	7.5	250	5	24	250	4800 min	0.100	680
0402AS-8N2J-YY	8.2	250	5	24	250	4400 min	0.100	680
0402AS-8N7J-YY	8.7	250	5	22	250	4160 min	0.160	681
0402AS-9N0J-YY	9.0	250	5	22	250	4160 min	0.160	681
0402AS-9N1J-YY	9.1	250	5	22	250	4000 min	0.200	480
0402AS-9N5J-YY	9.5	250	5	22	250	4000 min	0.200	480
0402AS-010J-YY	10	250	5	21	250	3900 min	0.200	480
0402AS-011J-YY	11	250	5	24	250	3680 min	0.170	640
0402AS-012J-YY	12	250	5	24	250	3600 min	0.170	640
0402AS-013J-YY	13	250	5	24	250	3600 min	0.170	640
0402AS-015J-YY	15	250	5	24	250	3280 min	0.170	560
0402AS-016J-YY	16	250	5	24	250	3100 min	0.220	560
0402AS-018J-YY	18	250	5	25	250	3100 min	0.23	420
0402AS-019J-YY	19	250	5	24	250	3040 min	0.24	480
0402AS-020J-YY	20	250	5	25	250	3000 min	0.25	420
0402AS-022J-YY	22	250	5	25	250	2800 min	0.30	400
0402AS-023J-YY	23	250	5	22	250	2720 min	0.30	400
0402AS-024J-YY	24	250	5	22	250	2480 min	0.30	400
0402AS-027J-YY	27	250	5	24	250	2480 min	0.30	400
0402AS-030J-YY	30	250	5	24	250	2350 min	0.30	400
0402AS-033J-YY	33	250	5	24	250	2350 min	0.30	320
0402AS-036J-YY	36	250	5	24	250	2320 min	0.44	320
0402AS-039J-YY	39	250	5	25	250	2100 min	0.55	200
0402AS-040J-YY	40	250	5	25	250	2100 min	0.83	150
0402AS-043J-YY	43	250	5	25	250	2100 min	0.70	150
0402AS-047J-YY	47	250	5	25	250	2100 min	0.83	150
* 0402AS-051J-YY	51	250	5	25	250	1760 min	0.97	100
* 0402AS-056J-YY	56	250	5	25	250	1760 min	0.97	100
* 0402AS-068J-YY	68	250	5	25	250	1620 min	0.97	100
* 0402AS-072J-YY	72	100	5	15	100	1070 min	1.20	80
* 0402AS-R10K-YY	100	100	10	15	100	1070 min	1.20	80
* 0402AS-R12K-YY	120	100	10	12	100	580 min	1.30	75
* 0402AS-R13K-YY	130	100	10	10	100	450 typ	1.30	70
* 0402AS-R15K-YY	150	100	10	13	100	400 typ	1.30	60
* 0402AS-R18K-YY	180	50	10	10	50	380 typ	1.50	65
* 0402AS-R20K-YY	200	50	10	10	50	400 typ	1.50	50
* 0402AS-R22K-YY	220	50	10	10	50	190 typ	2.00	50

**Core Material:** Ceramic

**SPQ:** Taped / Reel 1000 [-08]  
5000 [-01]

**Remarks:**

- Unlisted inductance values available upon request.
- 2% and 5% tolerance available upon request.
- All are AEC-Q200 Standard approved EXCEPT \*

## X-ON Electronics

Largest Supplier of Electrical and Electronic Components

*Click to view similar products for [RF inductors - SMD category](#):*

*Click to view products by [Fastron manufacturer](#):*

Other Similar products are found below :

[MHL1ECTTP82NJ](#) [MHL1ECTTP8N2J](#) [CIH10T12NJNC](#) [B82498B1332J000](#) [B82498B3121J000](#) [0805WL220GT](#) [1008WL101GT](#)  
[0805WL681GT](#) [IWC0402D27NR-3G](#) [IWC0603F68NR-3G](#) [IWC0402AR10R-3G](#) [0603WL470JT](#) [IWC0402D33NR-3G](#) [IWC0603F47NR-3G](#)  
[0805WL151JT](#) [IWC0402A68NR-3G](#) [IWC0402AR12R-3G](#) [IWC0402A82NR-3G](#) [IWC0402B39NR-3G](#) [IWC0603CR12R-3G](#)  
[IWC0603AR33R-3G](#) [IWC0603BR18R-3G](#) [IWC0603F39NR-3G](#) [IWC0603BR22R-3G](#) [IWC0402A47NR-3G](#) [IWC0603AR27R-3G](#)  
[IWC0603F27NR-3G](#) [IWC1008DR68R-3G](#) [IWC1008FR12R-3G](#) [IWC1008FR18R-3G](#) [IWC1008J33NR-3G](#) [IWC1008J82NR-3G](#)  
[IWC1008DR47R-3G](#) [IWC1008J18NR-3G](#) [IWC0805E22NR-3G](#) [IWC1008DR82R-3G](#) [IWC0805E33NR-3G](#) [IWC1008J68NR-3G](#)  
[IWC0805D82NR-3G](#) [IWC0805DR10R-3G](#) [IWC0805E39NR-3G](#) [IWC1008DR39R-3G](#) [IWC0805DR15R-3G](#) [IWC1008J39NR-3G](#)  
[IWC1008J27NR-3G](#) [IWC0805DR18R-3G](#) [IWC0805E68NR-3G](#) [IWC1008ER27R-3G](#) [IWC1008FR10R-3G](#) [IWC1008J22NR-3G](#)