

Chip Inductors for RF Applications / Medical Applications (Wire wound-open)

FASTRON's wire wound chip inductors are designed for radio frequency (RF) applications that require optimal Q on high frequency circuits. Its gold flash pad metallization provides better solderability for a higher yield in production. Additionally, their encapsulation not only protects the winding but also allows for surface mount assembly. It comes in compact sizes (from 0402 to 1812) and is available in reel packaging. Unlisted inductance values are usually available upon request. Ferrite core versions are also available for selected case sizes for applications which require higher inductances in a smaller case size.

Applications Used in LC resonant circuits such as oscillator and signal generators, impedance matching, RF filters etc.
 Mobile Telecommunication: GSM, CDMA, TCDMA, cordless phones, 2 way radio
 Automotive Subsystems: TPMS, Keyless Entry, Anti-Theft, GPS
 Wireless Communication: W-LAN, WIFI, WIMAX, RFID, Bluetooth
 Non-magnetic versions for medical imaging applications: ASM series

Technical Data

L – Value (Rated Inductance)	≥ 1 MHz measured with HP 4286A RF LCR meter or equivalent at frequency f_L , 25°C ambient < 1 MHz measured with HP 4285A or equivalent at frequency f_L , 25°C ambient
Q – Factor (min)	≥ 1 MHz measured with E4991B Impedance Analyzer or equivalent at frequency f_Q , 25°C ambient < 1 MHz measured with HP 4285A or equivalent at frequency f_Q , 25°C ambient
SRF (min)	Measured with HP8753ES Network Analyzer or equivalent at 25°C ambient
DCR (max)	Measured at 25°C ambient
Rated DC Current: Irms	Max permissible current that causes a 15°C component temperature rise from 25°C ambient for AS, AQ, ASM & F Max permissible current that causes a 40°C component temperature rise from 25°C ambient for AQC & FLP
Saturation Current: Isat	Max permissible DC bias at 25°C ambient that causes inductivity drop 30% (typ.) related to the unloaded inductivity for FLP.
Operating Temperature	-40°C to +100°C (Including component self-heating): F -40°C to +125°C (Including component self-heating): FLP -40°C to +140°C (Including component self-heating): AS, AQ, ASM & AQC
Surface Finishing	Epoxy molded flat top for perfect pick and place assembly
Pad Metallization	Gold flash as top layer for AS, AQ, F, AF & FLP Silver-Palladium-Platinum for ASM & AQC
Wire Termination	Spot welding
Recommended Soldering Method	Reflow
Moisture Sensitivity Levels (MSL)	MSL Level 1, indicating unlimited floor life at ≤ 30°C / 85% relative humidity
Solderability	Using lead free solder (Sn 99.9) at 260°C ± 5°C for 5 ± 0.5 seconds, min 90% solder coverage of metallization Standard: IEC 68-2-20 (Ta)
Resistance to Soldering Heat	Resistant to 260°C ± 5°C for 10 ± 1 seconds Standard: IEC 68-2-20 (Tb)
Resistance to Solvent	Resistant to isopropyl alcohol for 5 ± 0.5 minutes at 23°C ± 5°C Standard: IEC 68-2-45
Climatic Test	Defined by the following standards IEC 68-2-1 for Cold test: -55°C for 96 hours IEC 68-2-2 for Dry heat test: +85°C for ferrite core and 125°C for ceramic core for 96 hours IEC 60068-2-78 for Humidity test: 40°C at RH 95% for 4 days
Thermal Shock Test	Temperature cycle (ceramic): -40°C to +125°C to -40°C Temperature cycle (ferrite): -40°C to +85°C to -40°C Max/Min temperature duration: 15 minutes Temperature transition duration: 5 minutes Cycles: 25 Standard: MIL-STD-202G
Adhesion of Soldered Component (Shear Test)	Components withstand a pushing force of 10N for 10 ± 1 seconds Standard: IEC 60068-2-21, method Ue3
Mechanical Shock	Mil-Std 202 Method 213, Condition C 3 axis, 6 times, total 18 shocks 100 G, 6 ms, half-sine
Vibration	Mil-Std 202 Method 204 20 mins at 5G 10 Hz to 2000 Hz 12 cycles each of 3 orientations

Chip Inductors for RF Applications / Medical Applications (Wire wound-open)

Ordering Code Example : 0402AS-1N0X-YY → **0402AS-1N0K-01**

0402 AS - 1N0 X - YY
(Case Size) (Core Type) (Inductance Value) (Tolerance) (Packaging Code)

Case Sizes - 0402, 0603, 0805, 1008, 1206, 1210, 1812
Core Type - AS, AQ, AQC, ASM (Ceramic), F (Ferrite), AF (Ceramic & Ferrite), FLP (Ferrite Low Profile)
Tolerances - F ($\pm 1\%$), G ($\pm 2\%$), A ($\pm 3\%$), J ($\pm 5\%$), K ($\pm 10\%$), L ($\pm 15\%$), M ($\pm 20\%$)
Packaging Code - 01, 04, 08 (Taped / Reel)

Packaging Specification Schematic

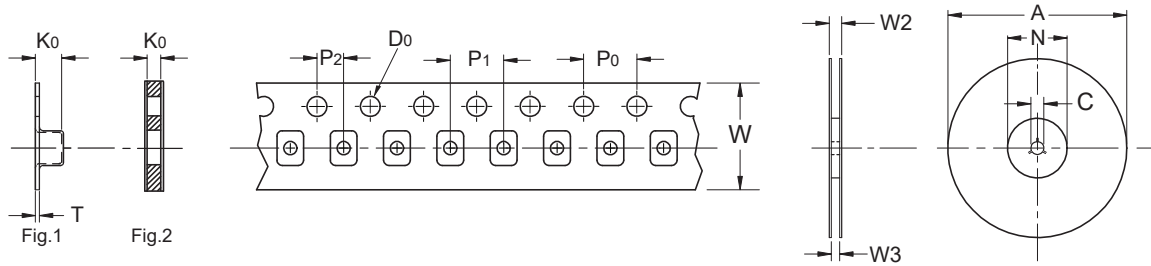

Type	Packaging Code	A	D0	N	C	W2	W3	W	P1	P0	P2	K0	T	Fig
0402	01,08	180	1.55	60	13	11.9	9.5	8	2	4	2	0.60	-	2
0603	01,08	180	1.55	60	13	11.4	9.0	8	4	4	2	0.98, 0.87*	-	2
0603	04	330	1.55	100	13	14.4	8.4	8	4	4	2	0.98, 0.87*	-	2
0805	01,08	180	1.55	60	13	11.4	9.0	8	4	4	2	1.63	0.25	1
0805	04	330	1.55	100	13	14.4	8.4	8	4	4	2	1.63	0.25	1
1008	01,08	180	1.50	60	13	11.4	9.5	8	4	4	2	2.23	0.30	1
1008	04	330	1.55	100	13	14.4	8.4	8	4	4	2	1.63	0.25	1
1206	01,08	180	1.50	60	13	18.4	13.7	12	4	4	2	1.80	0.30	1
1206	04	330	1.50	100	13	18.4	12.4	12	4	4	2	1.80	0.30	1
1210	01	180	1.55	60	13	18.4	13.7	12	8	4	2	2.55	0.30	1
1210	04	330	1.55	100	13	18.4	12.4	12	8	4	2	2.55	0.30	1
1812	01	180	1.50	60	13	18.4	13.7	12	8	4	2	3.70	0.35	1
1812	04	330	1.50	100	13	18.4	12.4	12	8	4	2	3.70	0.35	1

* is for FLP series

0603 FLP



Semi-shielded

Low Profile Design

Engineer's Kit: EK-0603FLP-X

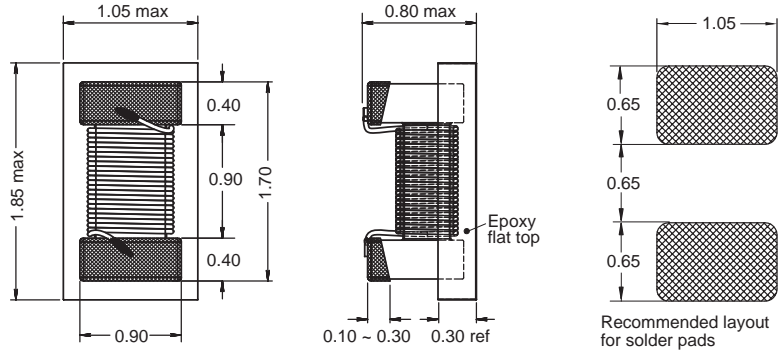
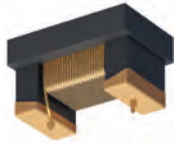

Chip Inductors for RF Applications

Wire wound - open

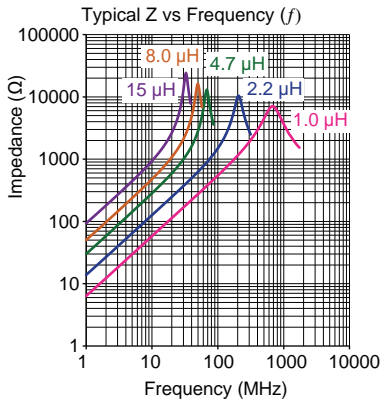
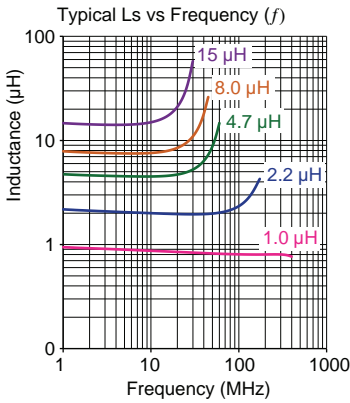

Part No	Inductance	f _L	Tol	SRF	DCR	Rated DC Current (mA)	
	L (µH)	(MHz)	± (%)	typ (MHz)	max (Ω)	I _{sat}	I _{rms}
0603FLP-R56M-YY	0.56	1.0	20	850	0.300	0.700	0.680
0603FLP-R68M-YY	0.68	1.0	20	670	0.350	0.620	0.600
0603FLP-1R0M-YY	1.0	1.0	20	450	0.380	0.560	0.540
0603FLP-1R5M-YY	1.5	1.0	20	175	0.520	0.440	0.420
0603FLP-2R2M-YY	2.2	1.0	20	150	0.750	0.380	0.350
0603FLP-4R7M-YY	4.7	1.0	20	55	1.050	0.300	0.300
0603FLP-6R8M-YY	6.8	1.0	20	40	1.500	0.240	0.280
0603FLP-8R0M-YY	8.0	1.0	20	40	2.500	0.200	0.200
0603FLP-100M-YY	10	1.0	20	30	2.900	0.180	0.180
0603FLP-150M-YY	15	1.0	20	25	3.600	0.140	0.140

Core Material: Ferrite

Revision date: 12 Dec 2023

SPQ: Taped / Reel 1000 [-08]
4000 [-01]
15000 [-04]

Remarks: Unlisted inductance values available upon request.

X-ON Electronics

Largest Supplier of Electrical and Electronic Components

Click to view similar products for [RF inductors - SMD category](#):

Click to view products by [Fastron manufacturer](#):

Other Similar products are found below :

[MHL1ECTTP82NJ](#) [MHL1ECTTP8N2J](#) [CIH10T12NJNC](#) [B82498B1332J000](#) [B82498B3121J000](#) [0805WL220GT](#) [1008WL101GT](#)
[0805WL681GT](#) [IWC0402D27NR-3G](#) [IWC0603F68NR-3G](#) [IWC0402AR10R-3G](#) [0603WL470JT](#) [IWC0402D33NR-3G](#) [IWC0603F47NR-3G](#)
[0805WL151JT](#) [IWC0402A68NR-3G](#) [IWC0402AR12R-3G](#) [IWC0402A82NR-3G](#) [IWC0402B39NR-3G](#) [IWC0603CR12R-3G](#)
[IWC0603AR33R-3G](#) [IWC0603BR18R-3G](#) [IWC0603F39NR-3G](#) [IWC0603BR22R-3G](#) [IWC0402A47NR-3G](#) [IWC0603AR27R-3G](#)
[IWC0603F27NR-3G](#) [IWC1008DR68R-3G](#) [IWC1008FR12R-3G](#) [IWC1008FR18R-3G](#) [IWC1008J33NR-3G](#) [IWC1008J82NR-3G](#)
[IWC1008DR47R-3G](#) [IWC1008J18NR-3G](#) [IWC0805E22NR-3G](#) [IWC1008DR82R-3G](#) [IWC0805E33NR-3G](#) [IWC1008J68NR-3G](#)
[IWC0805D82NR-3G](#) [IWC0805DR10R-3G](#) [IWC0805E39NR-3G](#) [IWC1008DR39R-3G](#) [IWC0805DR15R-3G](#) [IWC1008J39NR-3G](#)
[IWC1008J27NR-3G](#) [IWC0805DR18R-3G](#) [IWC0805E68NR-3G](#) [IWC1008ER27R-3G](#) [IWC1008FR10R-3G](#) [IWC1008J22NR-3G](#)