

Chip Inductors for RF Applications / Medical Applications (Wire wound-open)

FASTRON's wire wound chip inductors are designed for radio frequency (RF) applications that require optimal Q on high frequency circuits. Its gold flash pad metallization provides better solderability for a higher yield in production. Additionally, their encapsulation not only protects the winding but also allows for surface mount assembly. It comes in compact sizes (from 0402 to 1812) and is available in reel packaging. Unlisted inductance values are usually available upon request. Ferrite core versions are also available for selected case sizes for applications which require higher inductances in a smaller case size.

Applications Used in LC resonant circuits such as oscillator and signal generators, impedance matching, RF filters etc.
 Mobile Telecommunication: GSM, CDMA, TCDMA, cordless phones, 2 way radio
 Automotive Subsystems: TPMS, Keyless Entry, Anti-Theft, GPS
 Wireless Communication: W-LAN, WIFI, WIMAX, RFID, Bluetooth
 Non-magnetic versions for medical imaging applications: ASM series

Technical Data

L – Value (Rated Inductance)	≥ 1 MHz measured with HP 4286A RF LCR meter or equivalent at frequency f_L , 25°C ambient < 1 MHz measured with HP 4285A or equivalent at frequency f_L , 25°C ambient
Q – Factor (min)	≥ 1 MHz measured with E4991B Impedance Analyzer or equivalent at frequency f_Q , 25°C ambient < 1 MHz measured with HP 4285A or equivalent at frequency f_Q , 25°C ambient
SRF (min)	Measured with HP8753ES Network Analyzer or equivalent at 25°C ambient
DCR (max)	Measured at 25°C ambient
Rated DC Current: Irms	Max permissible current that causes a 15°C component temperature rise from 25°C ambient for AS, AQ, ASM & F Max permissible current that causes a 40°C component temperature rise from 25°C ambient for AQC & FLP
Saturation Current: Isat	Max permissible DC bias at 25°C ambient that causes inductivity drop 30% (typ.) related to the unloaded inductivity for FLP.
Operating Temperature	-40°C to +100°C (Including component self-heating): F -40°C to +125°C (Including component self-heating): FLP -40°C to +140°C (Including component self-heating): AS, AQ, ASM & AQC
Surface Finishing	Epoxy molded flat top for perfect pick and place assembly
Pad Metallization	Gold flash as top layer for AS, AQ, F & AF Silver-Palladium-Platinum for ASM & AQC Tin as top layer for FLP
Wire Termination	Spot welding
Recommended Soldering Method	Reflow
Moisture Sensitivity Levels (MSL)	MSL Level 1, indicating unlimited floor life at ≤ 30°C / 85% relative humidity
Solderability	Using lead free solder (Sn 99.9) at 260°C ± 5°C for 5 ± 0.5 seconds, min 90% solder coverage of metallization Standard: IEC 68-2-20 (Ta)
Resistance to Soldering Heat	Resistant to 260°C ± 5°C for 10 ± 1 seconds Standard: IEC 68-2-20 (Tb)
Resistance to Solvent	Resistant to isopropyl alcohol for 5 ± 0.5 minutes at 23°C ± 5°C Standard: IEC 68-2-45
Climatic Test	Defined by the following standards IEC 68-2-1 for Cold test: -55°C for 96 hours IEC 68-2-2 for Dry heat test: +85°C for ferrite core and 125°C for ceramic core for 96 hours IEC 60068-2-78 for Humidity test: 40°C at RH 95% for 4 days
Thermal Shock Test	Temperature cycle (ceramic): -40°C to +125°C to -40°C Temperature cycle (ferrite): -40°C to +85°C to -40°C Max/Min temperature duration: 15 minutes Temperature transition duration: 5 minutes Cycles: 25 Standard: MIL-STD-202G
Adhesion of Soldered Component (Shear Test)	Components withstand a pushing force of 10N for 10 ± 1 seconds Standard: IEC 60068-2-21, method Ue3
Mechanical Shock	Mil-Std 202 Method 213, Condition C 3 axis, 6 times, total 18 shocks 100 G, 6 ms, half-sine
Vibration	Mil-Std 202 Method 204 20 mins at 5G 10 Hz to 2000 Hz 12 cycles each of 3 orientations

Chip Inductors for RF Applications / Medical Applications (Wire wound-open)

Ordering Code Example : 0402AS-1N0X-YY → **0402AS-1N0K-01**

0402 AS - 1N0 X - YY
(Case Size) (Core Type) (Inductance Value) (Tolerance) (Packaging Code)

Case Sizes - 0402, 0603, 0805, 1008, 1206, 1210, 1812

Core Type - AS, AQ, AQC, ASM (Ceramic), F (Ferrite), AF (Ceramic & Ferrite), FLP (Ferrite Low Profile)

Tolerances - F (1%), G (2%), A (3%), J (5%), K (10%), L (15%), M (20%)

Packaging Code - 01, 04, 08 (Taped / Reel)

Packaging Specification Schematic

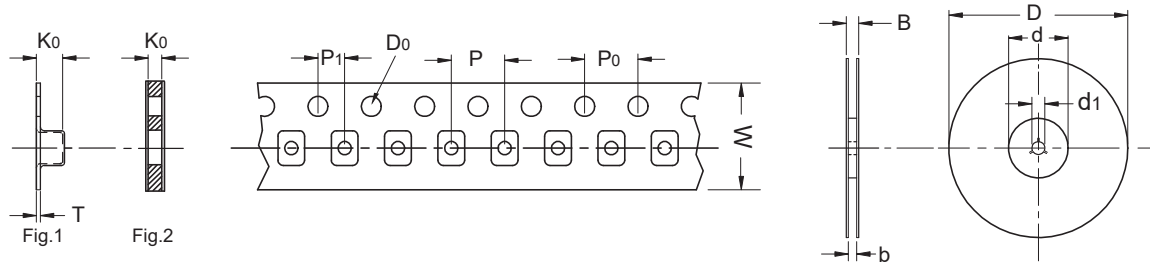

Type	Packaging Code	D	D0	d	d1	B	b	W	P	P0	P1	K0	T	Fig
0402	01,08	180	1.55	60	13	11.9	9.5	8	2	4	2	0.60	-	2
0603	01,08	180	1.55	60	13	11.4	9.0	8	4	4	2	0.98	-	2
0603	04	330	1.55	100	13	14.4	8.4	8	4	4	2	0.98	-	2
0805	01,08	180	1.55	60	13	11.4	9.0	8	4	4	2	1.63	0.25	1
0805	04	330	1.55	100	13	14.4	8.4	8	4	4	2	1.63	0.25	1
1008	01,08	180	1.50	60	13	11.4	9.5	8	4	4	2	2.23	0.30	1
1008	04	330	1.55	100	13	14.4	8.4	8	4	4	2	1.63	0.25	1
1206	01,08	180	1.50	60	13	18.4	13.7	12	4	4	2	1.80	0.30	1
1206	04	330	1.50	100	13	18.4	12.4	12	4	4	2	1.80	0.30	1
1210	01	180	1.55	60	13	18.4	13.7	12	8	4	2	2.55	0.30	1
1210	04	330	1.55	100	13	18.4	12.4	12	8	4	2	2.55	0.30	1
1812	01	180	1.50	60	13	18.4	13.7	12	8	4	2	3.70	0.35	1
1812	04	330	1.50	100	13	18.4	12.4	12	8	4	2	3.70	0.35	1

FASTRON's Component Key Characteristics



Approved according to AEC-Q200



Approved according to AEC-Q200 with High Temperature



Suitable for High Temperature



Part is RoHS conform and Halogen free



Mechanical Shock and Vibration Proof



Designed for High Q-values



Exceptionally High Q-values



Optimized for High Currents



Optimized for High Voltages

1210 ASM

Non-magnetic

Engineer's Kit: EK-1210ASM-X

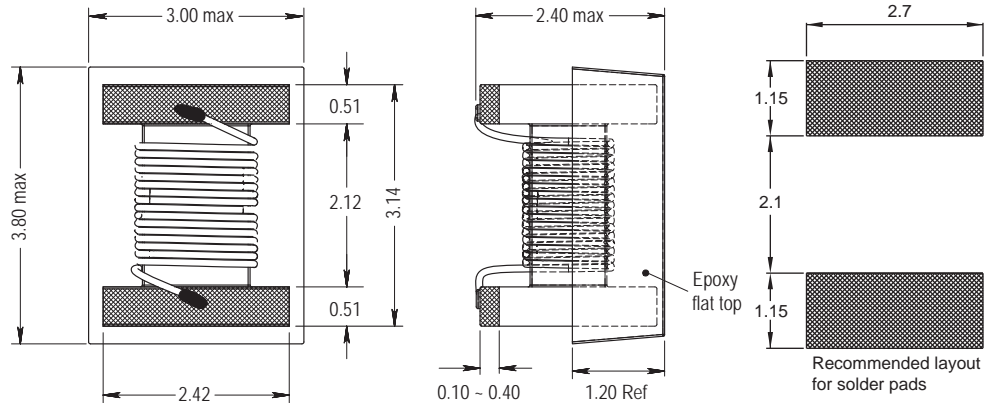
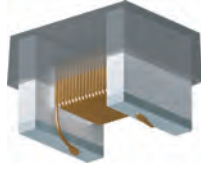

Chip Inductors for RF / Medical Applications

(Wire wound - open)

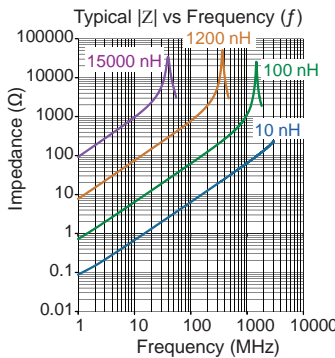
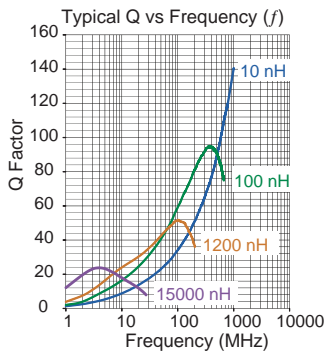
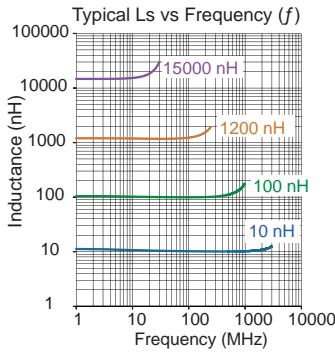

Single layer (typ)

Part No	Inductance L (nH)	f _L (MHz)	Tol ± (%)	Q min	f _Q (MHz)	SRF (MHz)	DCR max (Ω)	Rated DC Current max (mA)
1210ASM-010K-YY	10	50	10	50	500	4100 min	0.08	1000
1210ASM-012K-YY	12	50	10	50	500	2400 min	0.09	1000
1210ASM-015K-YY	15	50	10	50	500	2400 min	0.10	1000
1210ASM-018K-YY	18	50	10	50	350	2400 min	0.11	1000
1210ASM-022K-YY	22	50	10	55	350	2400 min	0.12	1000
1210ASM-027J-YY	27	50	5	55	350	1800 min	0.13	1000
1210ASM-033J-YY	33	50	5	60	350	1600 min	0.14	1000
1210ASM-039J-YY	39	50	5	60	350	1500 min	0.15	1000
1210ASM-047J-YY	47	50	5	65	350	1200 min	0.16	1000
1210ASM-056J-YY	56	50	5	65	350	1200 min	0.16	1000
1210ASM-068J-YY	68	50	5	65	350	1000 min	0.20	1000
1210ASM-082J-YY	82	50	5	60	350	1000 min	0.22	1000
1210ASM-R10J-YY	100	25	5	60	350	1000 min	0.24	980
1210ASM-R12J-YY	120	25	5	60	350	850 min	0.26	920
1210ASM-R15J-YY	150	25	5	50	100	750 min	0.29	870
1210ASM-R18J-YY	180	25	5	50	100	700 min	0.31	830
1210ASM-R22J-YY	220	25	5	50	100	650 min	0.35	790
1210ASM-R27J-YY	270	25	5	45	100	600 min	0.42	730
1210ASM-R33J-YY	330	25	5	45	100	500 min	0.49	680
1210ASM-R39J-YY	390	25	5	45	100	500 min	0.54	640
1210ASM-R47J-YY	470	25	5	45	100	450 min	0.60	610
1210ASM-R56J-YY	560	25	5	45	100	415 min	1.00	460
1210ASM-R68J-YY	680	25	5	45	100	350 min	1.15	420
1210ASM-R82J-YY	820	25	5	45	100	350 min	1.93	350
1210ASM-1R0K-YY	1000	25	10	35	50	290 typ	2.16	330
1210ASM-1R2K-YY	1200	7.9	10	35	50	250 typ	2.38	310
1210ASM-1R5K-YY	1500	7.9	10	25	50	200 typ	2.64	300
1210ASM-1R8K-YY	1800	7.9	10	25	50	160 typ	2.76	290
1210ASM-2R2K-YY	2200	7.9	10	25	50	160 typ	2.98	280
1210ASM-2R7K-YY	2700	7.9	10	25	25	140 typ	3.30	260
1210ASM-3R3K-YY	3300	7.9	10	25	25	120 typ	3.66	250
1210ASM-3R9K-YY	3900	7.9	10	20	25	100 typ	4.00	240
1210ASM-4R7K-YY	4700	7.9	10	20	25	90 typ	4.30	230
1210ASM-5R6K-YY	5600	7.9	10	15	25	60 typ	4.30	230
1210ASM-6R8K-YY	6800	7.9	10	15	25	60 typ	5.20	210
1210ASM-8R2K-YY	8200	7.9	10	17	7.9	45 typ	5.90	168
1210ASM-100K-YY	10000	7.9	10	17	7.9	38 typ	6.00	160
1210ASM-150K-YY	15000	7.9	10	15	7.9	20 typ	7.00	120

Core Material: Ceramic

Revision date: 11 Jan 2022

SPQ: Taped / Reel 800 [-01]
3000 [-04]

Remarks: - Unlisted inductance values available upon request.
- 2% and 5% tolerance available upon request.

X-ON Electronics

Largest Supplier of Electrical and Electronic Components

Click to view similar products for [RF inductors - SMD category](#):

Click to view products by [Fastron manufacturer](#):

Other Similar products are found below :

[MHL1ECTTP82NJ](#) [MHL1ECTTP8N2J](#) [CIH10T12NJNC](#) [B82498B1332J000](#) [B82498B3121J000](#) [0805WL220GT](#) [1008WL101GT](#)
[0805WL681GT](#) [IWC0402D27NR-3G](#) [IWC0603F68NR-3G](#) [IWC0402AR10R-3G](#) [0603WL470JT](#) [IWC0402D33NR-3G](#) [IWC0603F47NR-3G](#)
[0805WL151JT](#) [IWC0402A68NR-3G](#) [IWC0402AR12R-3G](#) [IWC0402A82NR-3G](#) [IWC0402B39NR-3G](#) [IWC0603CR12R-3G](#)
[IWC0603AR33R-3G](#) [IWC0603BR18R-3G](#) [IWC0603F39NR-3G](#) [IWC0603BR22R-3G](#) [IWC0402A47NR-3G](#) [IWC0603AR27R-3G](#)
[IWC0603F27NR-3G](#) [IWC1008DR68R-3G](#) [IWC1008FR12R-3G](#) [IWC1008FR18R-3G](#) [IWC1008J33NR-3G](#) [IWC1008J82NR-3G](#)
[IWC1008DR47R-3G](#) [IWC1008J18NR-3G](#) [IWC0805E22NR-3G](#) [IWC1008DR82R-3G](#) [IWC0805E33NR-3G](#) [IWC1008J68NR-3G](#)
[IWC0805D82NR-3G](#) [IWC0805DR10R-3G](#) [IWC0805E39NR-3G](#) [IWC1008DR39R-3G](#) [IWC0805DR15R-3G](#) [IWC1008J39NR-3G](#)
[IWC1008J27NR-3G](#) [IWC0805DR18R-3G](#) [IWC0805E68NR-3G](#) [IWC1008ER27R-3G](#) [IWC1008FR10R-3G](#) [IWC1008J22NR-3G](#)