

Rail Current Measurement IC



General Description

The FP355 is a wide common mode range high side rail current measurement IC. It is suitable for power systems like battery charger or switching power supply applications. It includes a differential input amplifier and an NPN transistor with emitter output. With three external resistors, the rail current signal can be easily converted into an amplified voltage signal at the IC output pin. Also, the gain can be adjusted by changing the three external resistors values.

Features

- Independent Power Supply Voltage: 2.7 to 12V
- Wide Input Common-Mode Voltage: 2.7 to 12V
- Source Current Emitter Output
- Three Resistors Gain Set-up
- Wide Temperature Range: -20°C to +125°C
- Package: SOT23-5L

Applications

- Battery Charger
- High Side Rail Current Detector
- SPS (Adaptor)
- Current Sense Networking System

Typical Application Circuit

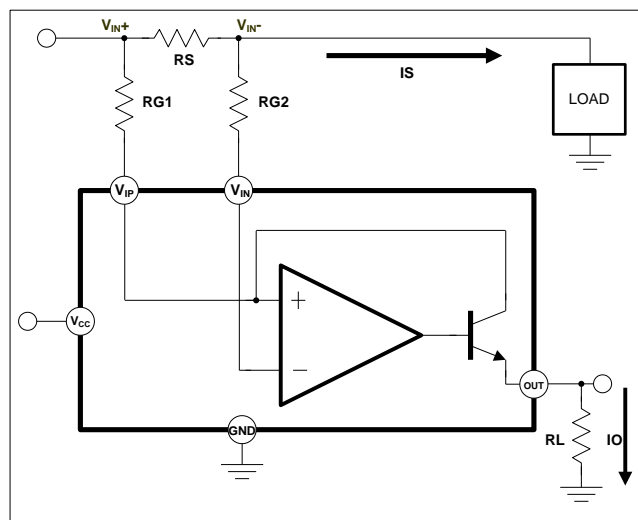

This datasheet contains new product information. Feeling Technology reserves the rights to modify the product specification without notice. No liability is assumed as a result of the use of this product. No rights under any patent accompany the sales of the product.

Function Block Diagram

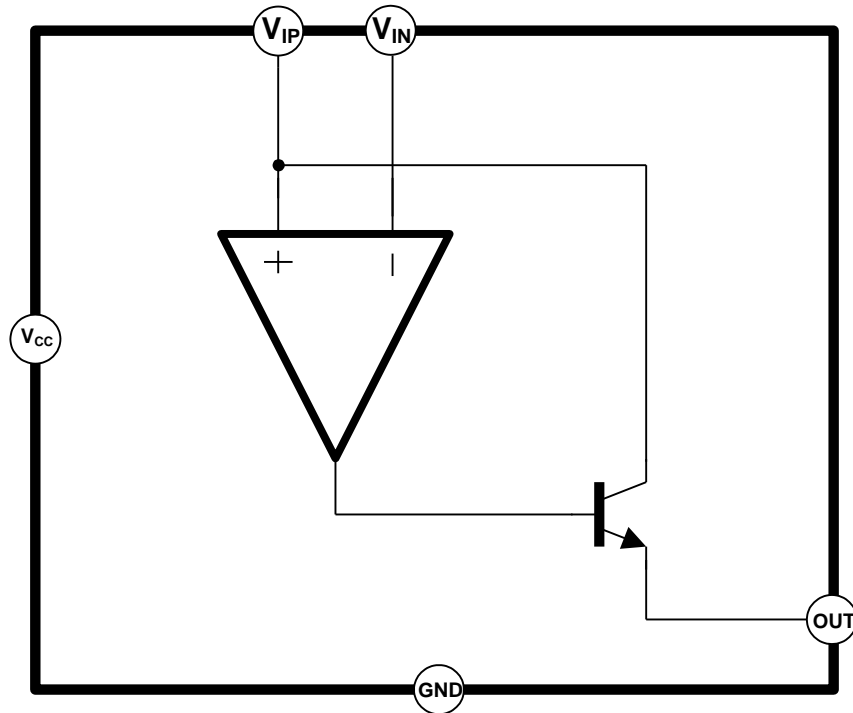

Pin Descriptions

SOT23-5L

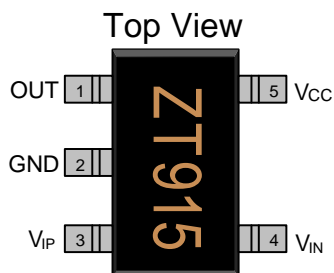

Name	No.	I / O	Description
OUT	1	O	Current Detect Output
GND	2	P	IC Ground
V _{IP}	3	I	Positive Input of Differential OPA
V _{IN}	4	I	Negative Input of Differential OPA
V _{CC}	5	P	IC Power Supply

Marking Information

SOT23-5L

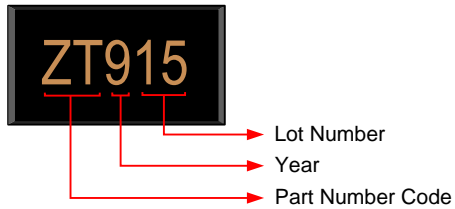

Lot Number: Wafer lot number's last two digits

For Example: 1323~~86~~TB → 86

Year: Production year's last digit

Part Number Code: Part number identification code for this product. It should be always "ZT".

Ordering Information

Part Number	Operating Temperature	Package	MOQ	Description
FP355KR-G1	-20°C ~ +125°C	SOT23-5L	3000EA	Tape & Reel

Absolute Maximum Ratings

Parameter	Symbol	Conditions	Min.	Typ.	Max.	Unit
Supply Voltage	V_{CC}		-0.3		12	V
Common Mode Inputs Voltage	V_i		-0.3		12	V
Differential Inputs Voltage ($V_{IP} - V_{IN}$)			-12		1.5	V
OUT Voltage			-0.3		12	V
Operating Temperature			-20		+125	°C
Storage Temperature			-55		+150	°C
Junction Temperature	T_J				+150	°C
Allowable Power Dissipation		$T_A=25^\circ\text{C}$			220	mW
Junction to Ambient Thermal Resistance	θ_{JA}				+250	°C / W
Junction to Case Thermal Resistance	θ_{JC}				+150	°C / W
SOT25 Lead Temperature (soldering, 10 sec)					+260	°C

IR Re-flow Soldering Curve

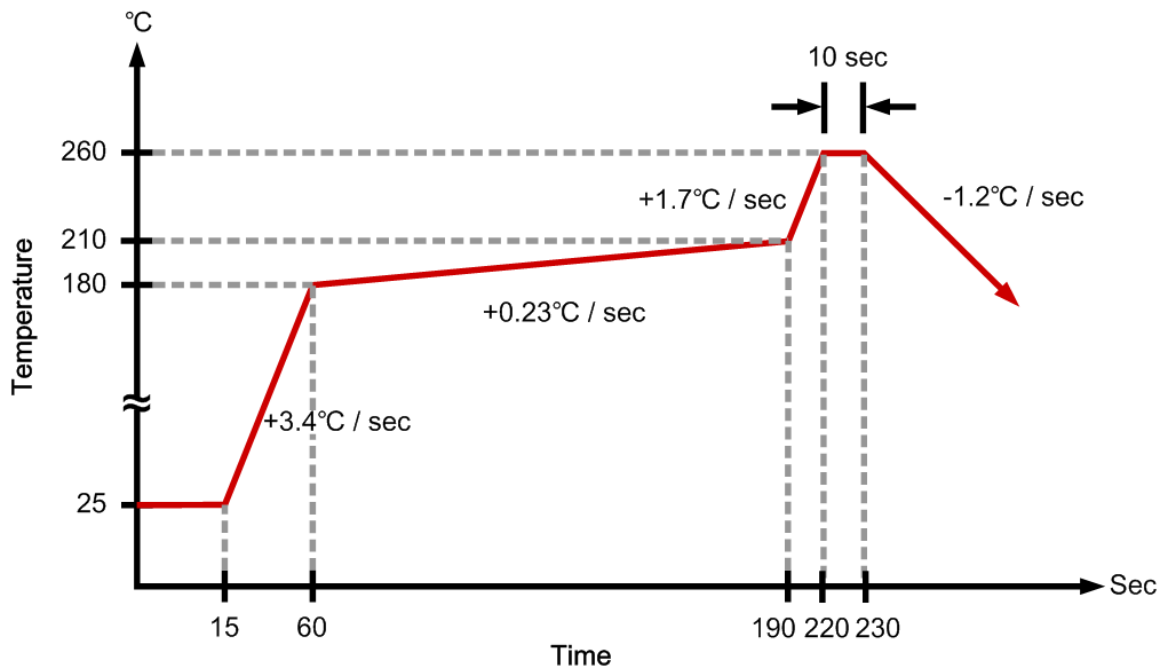

Recommended Operating Conditions

Parameter	Symbol	Conditions	Min.	Typ.	Max.	Unit
Supply Voltage	V_{CC}		2.7		12	V
Operating Temperature			-20		+125	°C

DC Electrical Characteristics

($V_{CC}=5V$, $V_{IN}^+=12V$, $R_{OUT}=125K\Omega$, $T_A=-20^{\circ}C\sim 125^{\circ}C$, unless otherwise noted)

Parameter	Symbol	Conditions	Min.	Typ.	Max.	Unit
Full Scale Sense Voltage	V_{SENSE}	$V_{SENSE}=V_{IN}^+ - V_{IN}^-$		100	500	mV
Common-Mode Input Voltage	V_{CM}		2.7		12	V
Common-Mode Rejection	CMRR	$V_{IN}^+=2.7V$ to 12V, $V_{SENSE}=50mV$	100	120		dB
Input Offset Voltage vs temp	$V_{OFFSET(TA)}$	T_{MIN} to T_{MAX}		4		$\mu V / ^{\circ}C$
Input Offset Voltage vs V_{CC}	$V_{OFFSET(VCC)}$	$V_{CC}=2.7V$ to 12V, $V_{SENSE}=50mV$		2.5	10	$\mu V/V$
Input Bias Current	I_{BIAS}	V_{IP}, V_{IN}		2		μA
Non-linearity Error	NLE	$V_{SENSE}=10mV$ to 150mV			± 1	%
Total Output Error	TOE	$V_{SENSE}=100mV$			± 2	%
Output Impedance	R_{OUT}			1 5		$G\Omega pF$
Voltage Swing to V_{CC}	V_{SCC}			$V_{CC}-0.8$		V
Voltage Swing to V_{CM}	V_{SCM}			$V_{CM}-0.5$		V
Bandwidth	BW	$R_{OUT}=125K\Omega$		32		kHz
Settling Time	T_s	5V Step, $R_{OUT}=125K\Omega$		30		μS
Output Current	I_{OUT}	$V_{CC}=V_{IN}^+=12V$, $V_{SENSE}=1V$, $RG1=RG2=1K\Omega$, $RL=10K\Omega$	350			μA
Total Output-Current Noise	I_{NOISE}	BW=100KHz		3		nA
Operating Voltage Range	V_{CC}		2.7		12	V
Quiescent Current	I_{CC}	$V_{SENSE}=0$, $V_{CC}=12V$		300		μA

Typical Operating Characteristics

($V_{CC}=5V$, $V_{IN}=12V$, $T_A=25^{\circ}C$, unless otherwise noted)

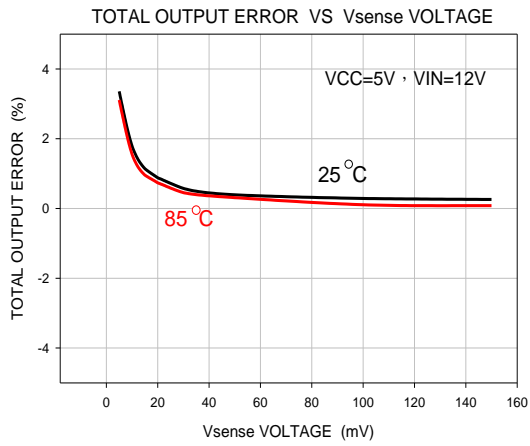

V_{OUT} (RG1=RG2=1K Ω)

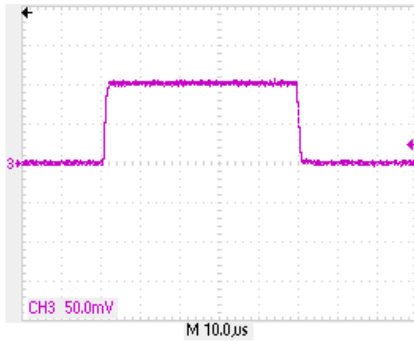

G=1

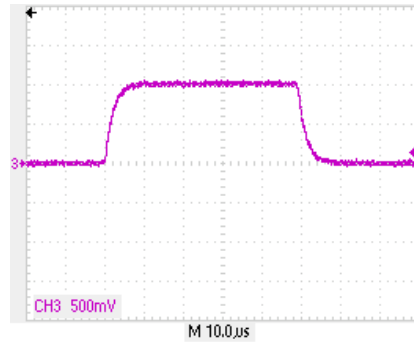

G=10

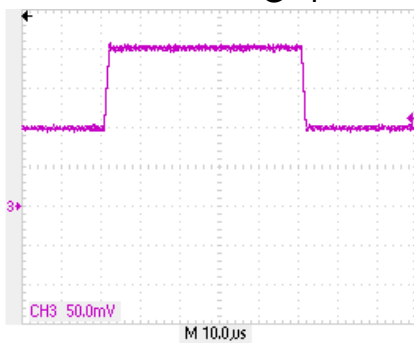

G=1

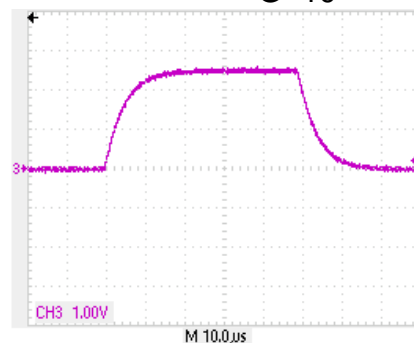

G=25

V_{OUT} (RG1=RG2=5K Ω)

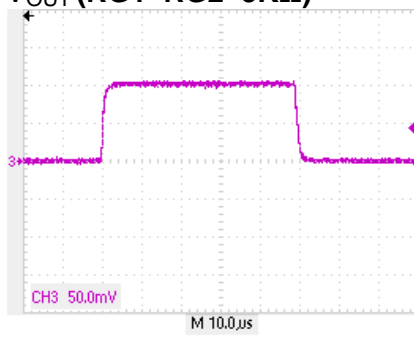

G=1

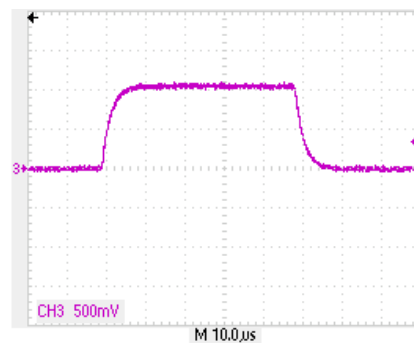

G=10

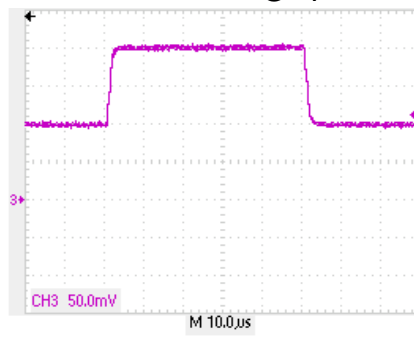

G=1

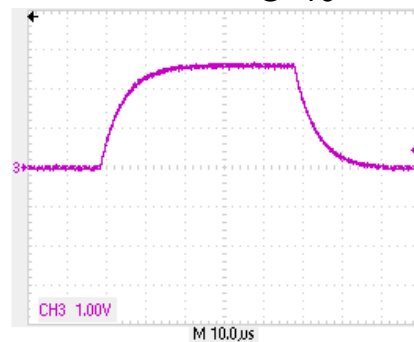

G=25

Function Description

Figure 1 shows the FP355 basic application circuit, the load current (I_S) flows from power supply and generates a voltage difference ($V_{IN}^+ - V_{IN}^-$) at the sense resistor (R_S). Assume internal NPN transistor collector current is same as emitter current (I_O) and V_{IP} is very close V_{IN} , the FP355 transfer function is:

$$I_O = \frac{V_{IN}^+ - V_{IN}^-}{R_{G1}} \quad \text{---- (1)}$$

In the circuit of Figure 1, the ($V_{IN}^+ - V_{IN}^-$), is equal to $I_S \times R_S$ and the output voltage (OUT) is equal to $I_O \times R_L$. The final transfer function for rail current measurement in this application is:

$$V_{OUT} = G \times I_S \times R_S \quad \text{---- (2)}$$

$$G = R_L / R_{G1} \quad \text{---- (3)}$$

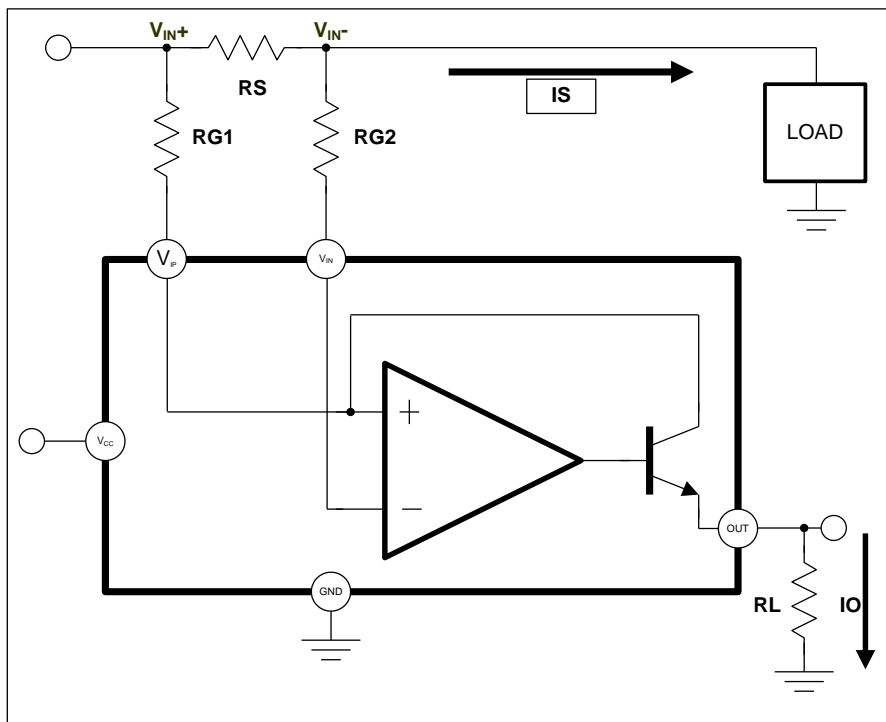

Figure 1 Current Measurement Circuit

Note:

1. The minimum operating voltages of V_{CC} , V_{IP} and V_{IN} are 2.7V. If these supply voltages are lower than 2.7V, the transfer function at output of FP355 is no longer applicable.
2. Do not force a V_{IN} voltage larger than $V_{IP} + 15V$. This condition would generate a leakage current and an incorrect voltage at FP355 output.

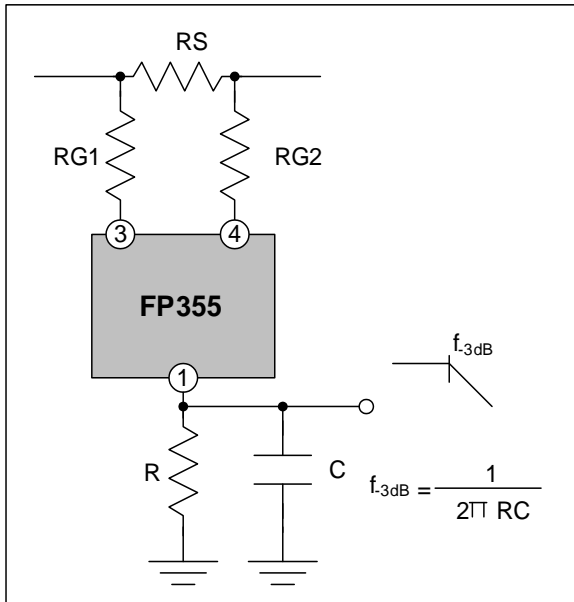

Figure 2 Output R-C Delay Circuit

Figure 2 shows a simple method to delay the converting time. When a transient voltage happens at sense resistor (R_S), the IC would change sourcing current (I_o) to the output and generate a voltage change at the output. The RC circuit will delay a time during output change.

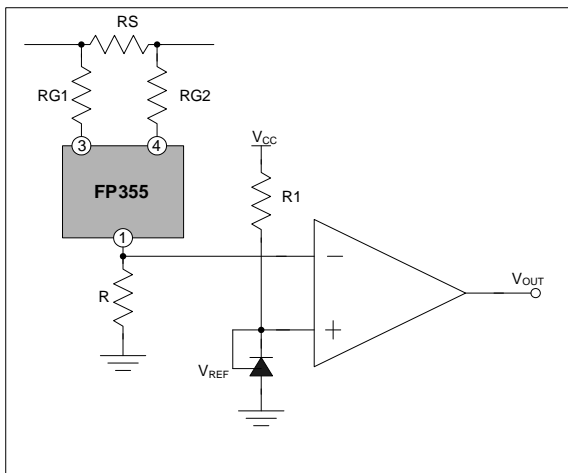

Figure 3 Comparator Detection Circuit

Figure 3 shows a detection circuit using 1.25V reference regulator and comparator.

At initial, the non-inverting input of the comparator which is connected to the 1.25V regulator is higher than inverting input. The comparator's output signal is high. Once the IC output voltage is higher than 1.25V, the comparator's output will change to low.

Package Outline

SOT23-5L

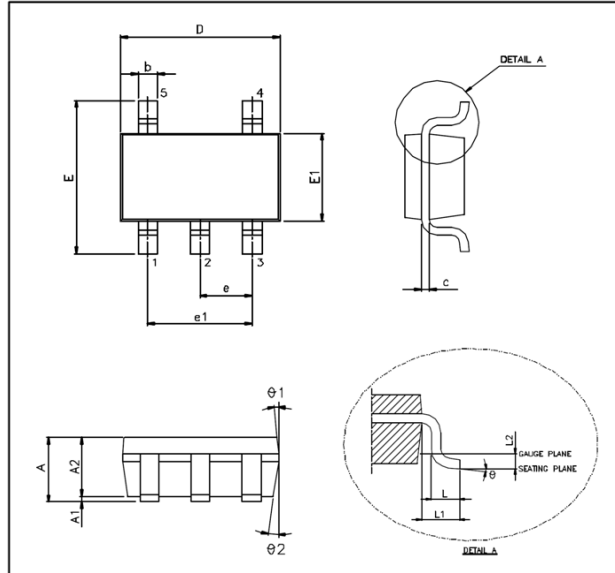

UNIT: mm

Symbols	Min. (mm)	Max.(mm)
A	1.050	1.350
A1	0.050	0.150
A2	1.000	1.200
b	0.250	0.500
c	0.080	0.200
D	2.700	3.000
E	2.600	3.000
E1	1.500	1.700
e	0.950 BSC	
e1	1.900 BSC	
L	0.300	0.550
L1	0.600 REF	
L2	0.250 BSC	
θ°	0°	10°
$\theta 1^\circ$	3°	7°
$\theta 2^\circ$	6°	10°

Note:

1. Package dimensions are in compliance with JEDEC outline: MO-178 AA.
2. Dimension "D" does not include molding flash, protrusions or gate burrs.
3. Dimension "E1" does not include inter-lead flash or protrusions.

X-ON Electronics

Largest Supplier of Electrical and Electronic Components

Click to view similar products for [Supervisory Circuits](#) category:

Click to view products by [Feeling manufacturer](#):

Other Similar products are found below :

[NCP304LSQ38T1G](#) [NCP304LSQ40T1G](#) [NCP304LSQ42T1G](#) [NCP304LSQ43T1G](#) [NCP304LSQ46T1G](#) [NCP305LSQ11T1G](#)
[NCP305LSQ16T1G](#) [NCP305LSQ17T1G](#) [NCP305LSQ18T1G](#) [NCP305LSQ24T1G](#) [NCP305LSQ25T1G](#) [NCP305LSQ29T1G](#)
[NCP305LSQ31T1G](#) [NCP305LSQ32T1G](#) [NCP308MT250TBG](#) [NCP308SN300T1G](#) [NCP391FCALT2G](#) [NCV303LSN42T1G](#)
[NCV308SN330T1G](#) [CAT1161LI-25-G](#) [CAT853STBI-T3](#) [MAX1232CPA](#) [MAX705CPA](#) [CAT1026LI-30-G](#) [CAT1320LI-25-G](#) [CAT872-30ULGT3](#) [LA-ispPAC-POWR1014-01TN48E](#) [NCP304HSQ18T1G](#) [NCP304HSQ29T1G](#) [NCP304LSQ27T1G](#) [NCP304LSQ29T1G](#)
[NCP304LSQ45T1G](#) [NCP305LSQ26T1G](#) [NCP305LSQ35T1G](#) [NCP305LSQ37T1G](#) [NCP308MT300TBG](#) [NCV300LSN36T1G](#)
[NCV302LSN30T1G](#) [NCV303LSN16T1G](#) [NCV303LSN22T1G](#) [NCV303LSN27T1G](#) [NCV33161DMR2G](#) [TC54VN2402EMB713](#)
[MCP1316T-44NE/OT](#) [MCP1316MT-45GE/OT](#) [MCP1316MT-23LI/OT](#) [MCP1316T-26LE/OT](#) [MAX8997EWW+](#) [MAX821RUS+T](#)
[MAX6725AKASYD3-LF-T](#)