

High Efficiency, 175kHz, Step-Down White LED Driver

General Description

The FP7195 is a current mode LED controller. The FP7195 includes a high-voltage startup regulator that operates over a wide input range of 6.5V to 80V. With 175kHz operating frequency, the size of the external PWM inductor and input/output capacitors can be minimized. Brightness dimming can be controlled from either analog or PWM signal.

Features

- High-side adjustable current sense
- PWM and analog dimming
- Internal thermal regulation
- Short circuit protection
- Under voltage lockout

Applications

- DC/DC LED driver applications
- Automotive
- Desk lights and room lighting
- MR16 LED spotlight
- LED backlighting
- Constant-current regulators

Typical Application Circuit

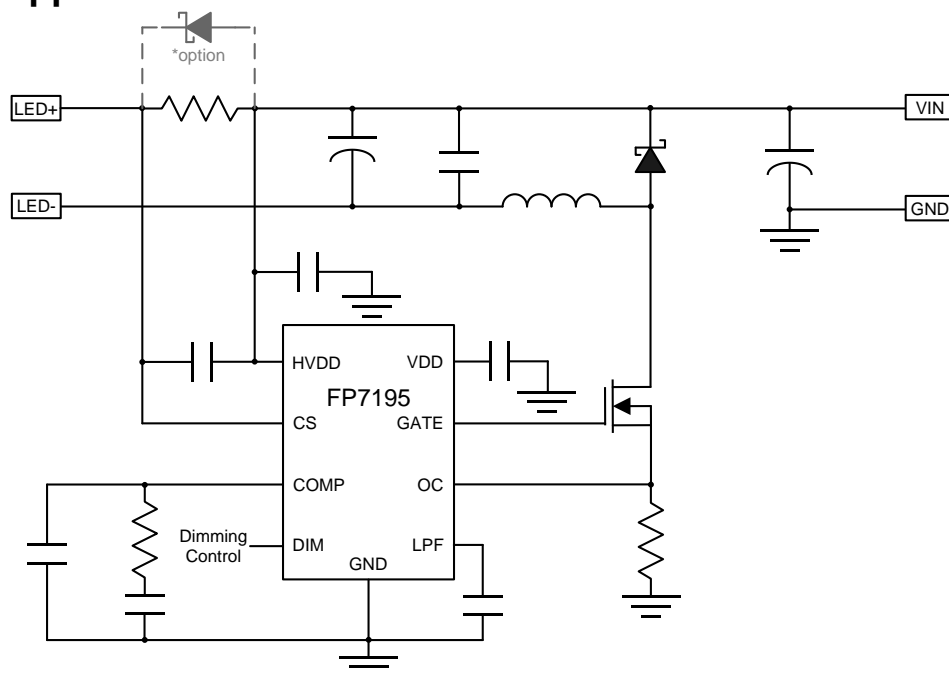

This datasheet contains new product information. Advanced Analog Technology reserves the rights to modify the product specification without notice. No liability is assumed as a result of the use of this product. No rights under any patent accompany the sales of the product.

Function Block Diagram

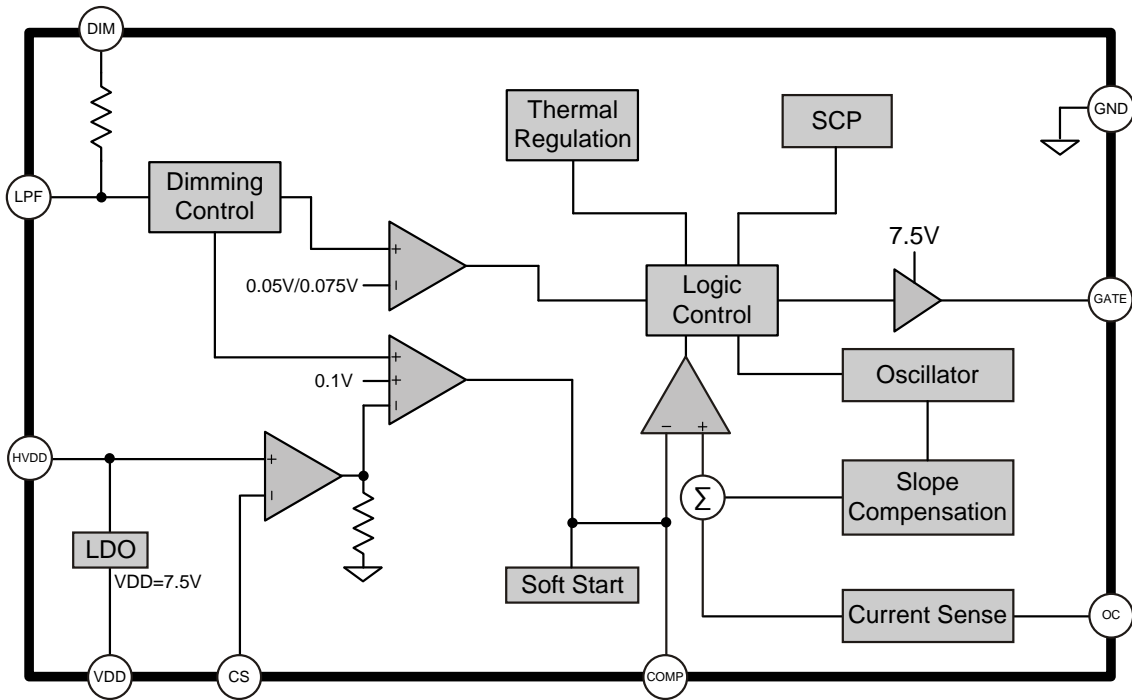

Pin Descriptions

SOP-8L(EP)

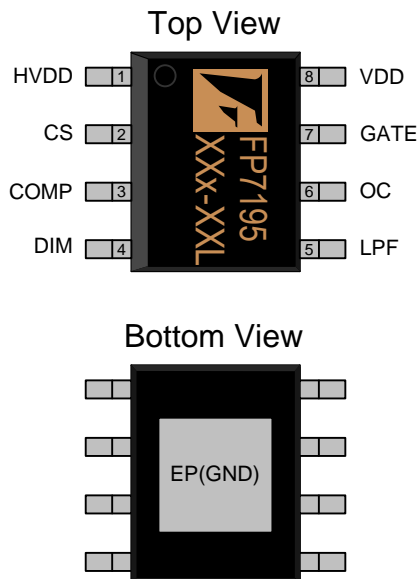

Name	No.	I / O	Description
HVDD	1	P	This is the power supply pin and positive current sense input.
CS	2	I	Negative current sense input.
COMP	3	I	Connect a resistor and capacitor to GND compensate control loop.
DIM	4	I	PWM and analog dimming input
LPF	5	I	Connect a capacitor to ground to filter out the AC ripple from dimming voltage.
OC	6	I	Current detect.
GATE	7	O	This pin is the output GATE driver for an external N-channel power MOSFET.
VDD	8	P	This is the power supply pin for all internal circuits.
EP(GND)	9	P	Ground return for all internal circuitry.

This datasheet contains new product information. Advanced Analog Technology reserves the rights to modify the product specification without notice. No liability is assumed as a result of the use of this product. No rights under any patent accompany the sales of the product.

Marking Information

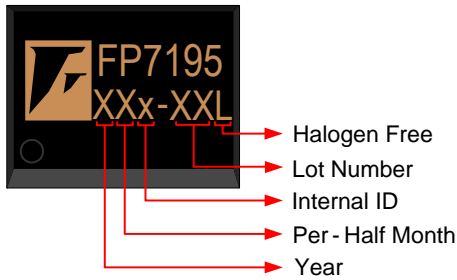

Halogen Free: Halogen free product indicator

Lot Number: Wafer lot number's last two digits

For Example → Lot : 123456 → XXx-56L

Internal ID: Internal Identification Code

Per-Half Month: Production period indicator in half month time unit

For Example : A → First Half Month of January
B → Second Half Month of January
C → First Half Month of February
D → Second Half Month of February

Year: Production year's last digit

Ordering Information

Part Number	Operating Temperature	Package	MOQ	Description
FP7195XR-G1	-25°C ~ +85°C	SOP-8L (EP)	2500EA	Tape & Reel

Absolute Maximum Ratings

Parameter	Symbol	Conditions	Min.	Typ.	Max.	Unit
Power Supply Voltage	H_{VDD}	H_{VDD} to GND	-0.3		85	V
	V_{DD}	V_{DD} to GND	-0.3		10	V
CS			$H_{VDD}-1.5$		H_{VDD}	V
GATE			-0.3		V_{DD}	
DIM, LPF, COMP, OC			-0.3		5.5	V
Allowable Power Dissipation	P_D	SOP-8L(EP) $T_A \leq +25^\circ\text{C}$			1500	mW
Junction to Case Thermal Resistance	θ_{JC}	SOP-8L(EP)			10	$^\circ\text{C} / \text{W}$
Junction to Ambient Thermal Resistance	θ_{JA}	SOP-8L(EP)			60	$^\circ\text{C} / \text{W}$
Storage Temperature	T_S		-40		+150	$^\circ\text{C}$
Lead Temperature		(soldering, 10 sec)			+260	$^\circ\text{C}$

IR Re-flow Soldering Curve

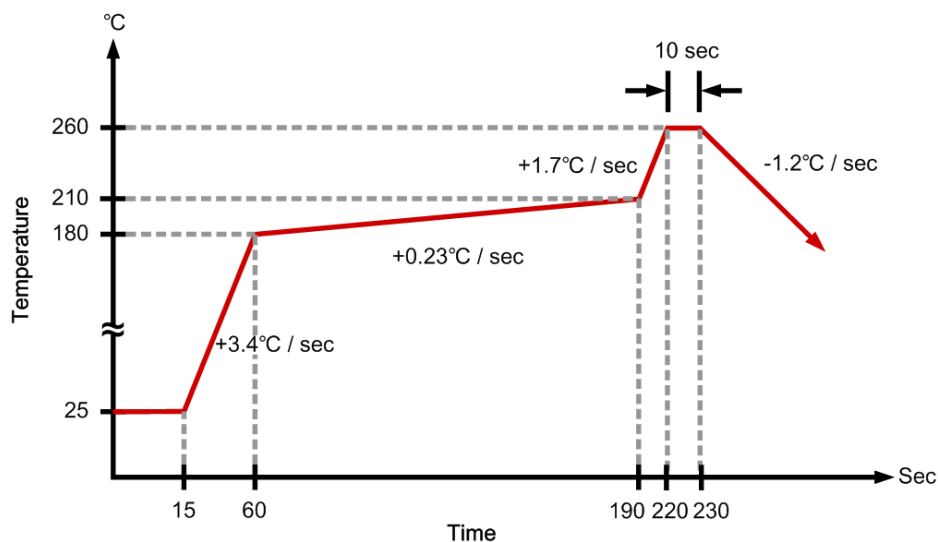

This datasheet contains new product information. Advanced Analog Technology reserves the rights to modify the product specification without notice. No liability is assumed as a result of the use of this product. No rights under any patent accompany the sales of the product.

Recommended Operating Conditions

Parameter	Symbol	Conditions	Min.	Typ.	Max.	Unit
Supply Voltage	$H_{V_{DD}}$		6.5		80	V
Operating Temperature			-25		85	°C

DC Electrical Characteristics (V_{OUT}=12V, T_A = 25°C, unless otherwise noted)

Parameter	Symbol	Conditions	Min.	Typ.	Max.	Unit
Internal Regulator						
Internally regulated voltage	V_{DD}	$H_{V_{DD}}=8V, I_{DD}=0A, V_{DIM}=0V$	7.27	7.5	7.73	V
Line regulation of V_{DD}	$\Delta V_{DD, line}$	$H_{V_{DD}}=8\sim 80V, V_{DIM}=5V$			50	mV
Load regulation of V_{DD}	$\Delta V_{DD, load}$	$H_{V_{DD}}=8V, V_{DIM}=5V, I_{DD}=0\sim 10mA$			100	mV
Shutdown current	I_{SHDN}	$H_{V_{DD}}=8\sim 80V, V_{DIM}=0V$		620		uA
$H_{V_{DD}}$ under voltage lockout threshold	V_{UVLO}	$H_{V_{DD}}$ rising		6		V
		V_{UVLO} hysteresis		0.5		V
Current Sense Logic						
Current sense voltage	$H_{V_{DD}}-V_{CS}$	$H_{V_{DD}}=12V, V_{DIM}=5V$	97	100	103	mV
CS pin input current	I_{CS}	$H_{V_{DD}}=24V, V_{CS}=24V$			20	uA
PWM Converter						
Switching frequency	f_{SW}			175		kHz
Maximum duty cycle	D_{MAX}		100			%
Minimum on-time	T_{MIN}			150	250	ns
GATE Driver						
GATE Pull-UP Resistance	R_{GH}	$V_{GATE} = 0V, V_{DD} = 7.5V$		0.7		Ω
GATE Pull-Down Resistance	R_{GL}	$V_{GATE} = V_{DD}, V_{DD} = 7.5V$		0.7		Ω

This datasheet contains new product information. Advanced Analog Technology reserves the rights to modify the product specification without notice. No liability is assumed as a result of the use of this product. No rights under any patent accompany the sales of the product.

Parameter	Symbol	Conditions	Min.	Typ.	Max.	Unit
Dimming						
Analog dimming disable		I _{LED} =100%		2.5		V
Analog dimming enable	V _{EN_DIM}	I _{LED} =0.1%		0.1		V
Enable voltage	V _{EN}			0.075		V
Shutdown voltage	V _{OFF}			0.05		V
DIM shutdown delay	T _{DELAY}			25		ms
Short Circuit Protection						
SCP current sense voltage	V _{SCP_CS}			240		mV
Restart delay time	T _{SCP}			45		ms
Thermal Regulation						
Internal thermal regulation enable	T _{THERMAL}	I _{LED} =100%		160		°C

This datasheet contains new product information. Advanced Analog Technology reserves the rights to modify the product specification without notice. No liability is assumed as a result of the use of this product. No rights under any patent accompany the sales of the product.

Function Description

Operation

FP7195 is a current mode controller for Buck current regulators which are ideal for driving LED loads. FP7195 has wide input voltage range allowing for regulation of a variety of LED loads. The control loop has a current amplifier to sense the voltage between HVDD and CS pins. The high side differential current sense, with low adjustable threshold voltage, provides an excellent method for regulating output current while maintaining high system efficiency.

LDO Mode

The FP7195's maximum duty cycle can reach 100%, that means the driver main switch is turn on through out whole clock cycle. Once the duty reaches 100%, the feedback path no longer controls the output current. The output current will be the input voltage minus the switch voltage drop.

LED Current Setting

The LED current could be calculated by following equation:

$$I_{LED} (A) = \frac{0.1(V)}{R_{SENSE}(\Omega)}$$

Internal Thermal Protection

FP7195 will reduce output current linearly when chip temperature over thermal protection threshold.

Short Circuit Protection

FP7195 will turn off switch MOSFET and rest for 45ms when HVDD-CS voltage over 240mV. FP7195 goes into hiccup mode. When HVDD-CS voltage drops below 240mV, the chip will recover from hiccup mode.

**Note: When LED+ short to LED-, output capacitor will discharge by very high current in a moment. High current will drop high voltage on R_{CS} . Once HVDD-CS voltage over 1.5V, the high current will go into HVDD pin and damage the chip. Add a schottky diode in parallel on R_{CS} can avoid high current damage the chip.*

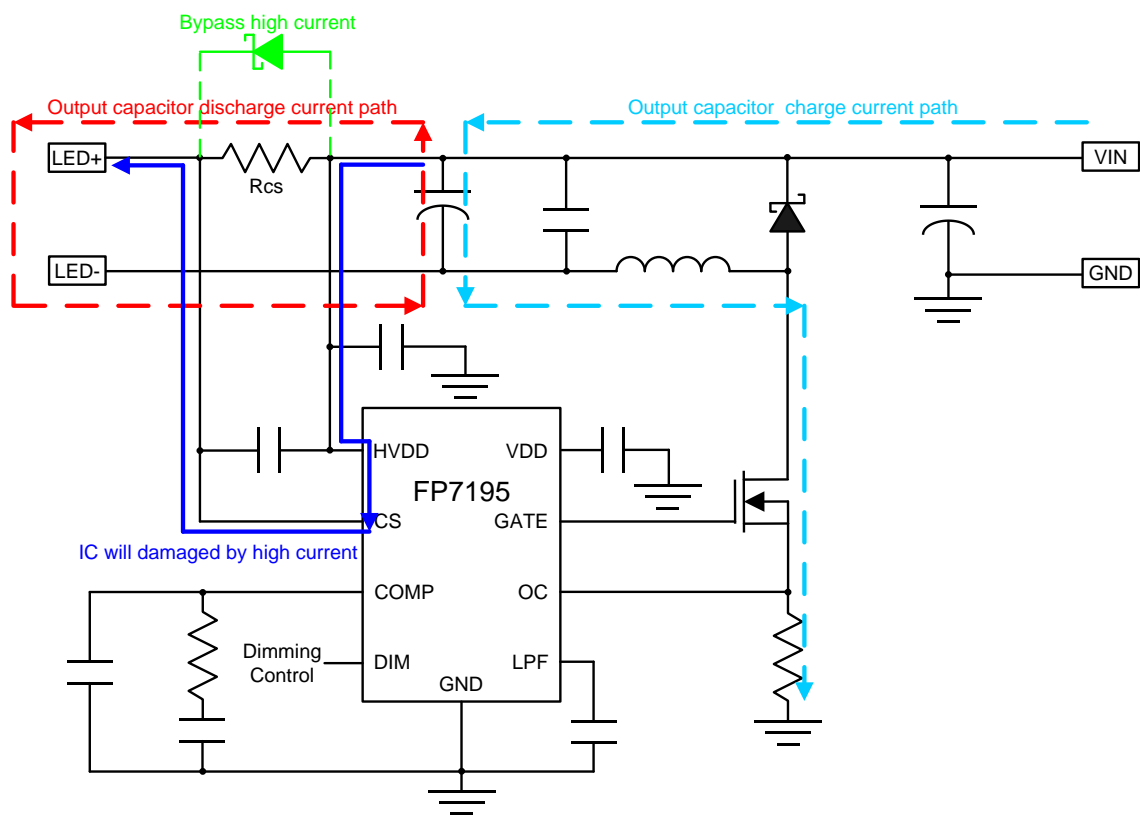

Brightness / Dimming Control

The FP7195 features both analog and digital dimming control. Analog dimming is linearly controlled by an external voltage on DIM pin.

- **Analog Dimming:**

FP7195 can control output current from 0.1% to 100% when V_{DIM} from 0.1V to 2.5V. Output current can be calculated using formula below.

$$I_{LED}(\%) = \frac{V_{DIM}(V) - 0.1V}{2.4} \times 100\%$$

- **Digital Dimming:**

FP7195 can digital dimming while input PWM signal into DIM pin. FP7195 can control output current from 0.1% to 100% when PWM duty from 4% to 100%. FP7195 allows a wide dimming frequency range from 500Hz to 200kHz. Output current can be calculated using formula below.

$$I_{LED}(\%) = \frac{2.5V \times \text{Duty} - 0.1V}{2.4} \times 100\%$$

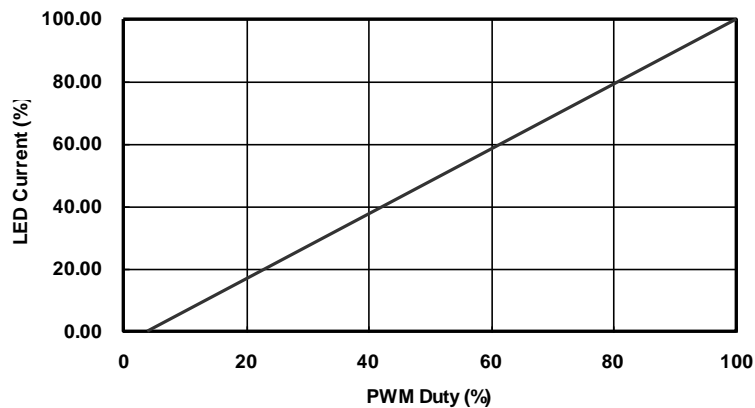

This datasheet contains new product information. Advanced Analog Technology reserves the rights to modify the product specification without notice. No liability is assumed as a result of the use of this product. No rights under any patent accompany the sales of the product.

※ $V_{IN}=80V$, LED=11V, $T_A = 25^{\circ}C$, unless otherwise noted

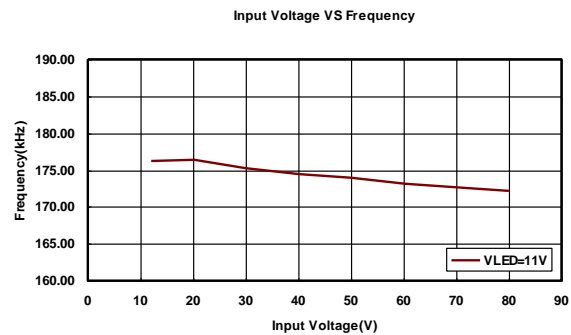
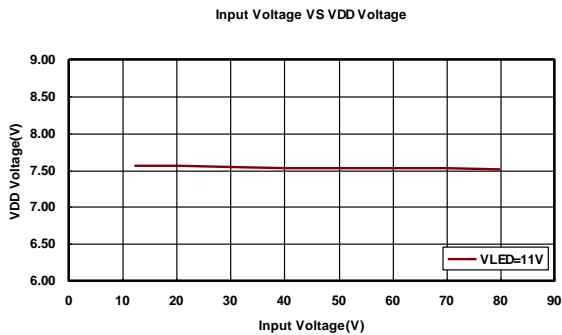
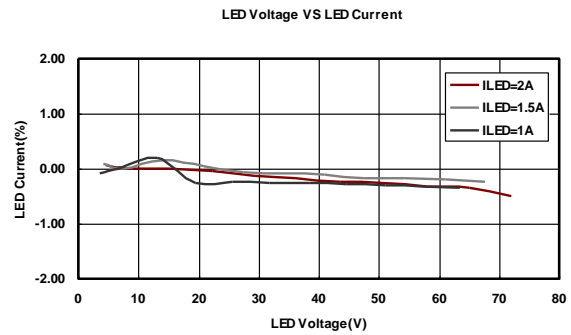
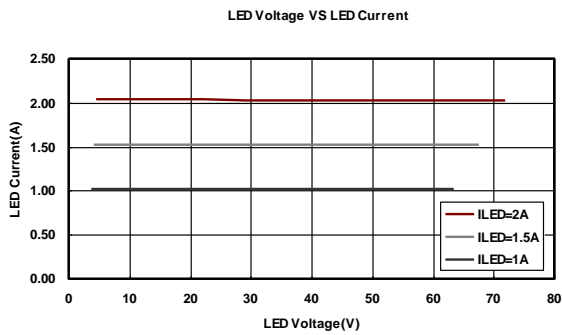
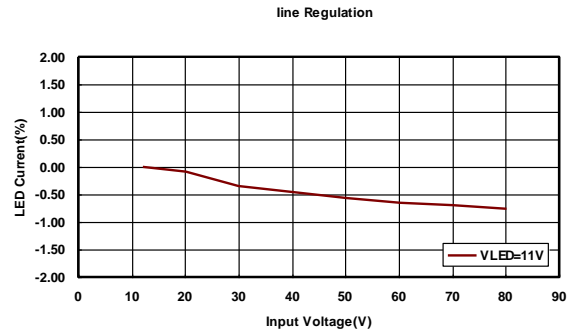
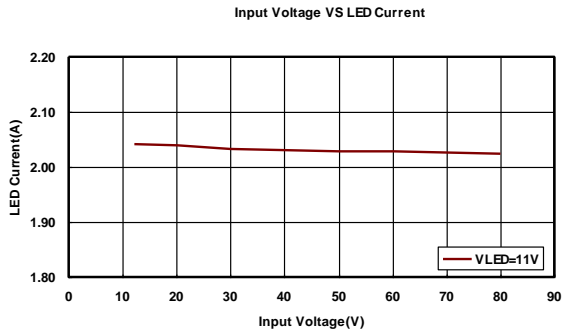

This datasheet contains new product information. Advanced Analog Technology reserves the rights to modify the product specification without notice. No liability is assumed as a result of the use of this product. No rights under any patent accompany the sales of the product.

※ $V_{IN}=48V$, $LED=24V$, $T_A = 25^{\circ}C$, unless otherwise noted

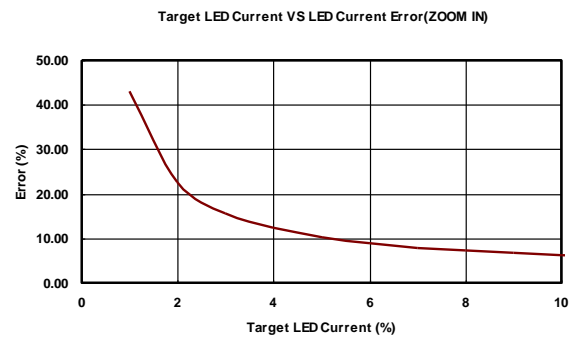
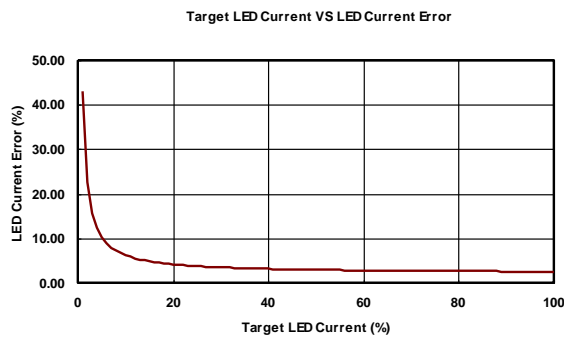
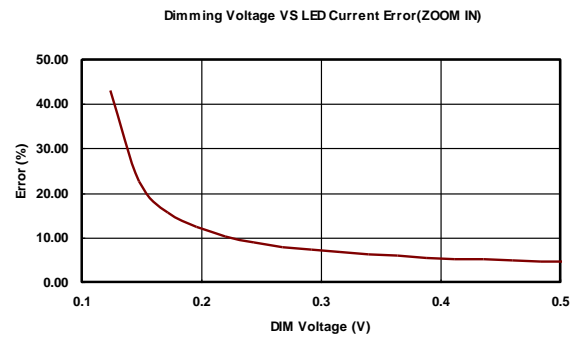
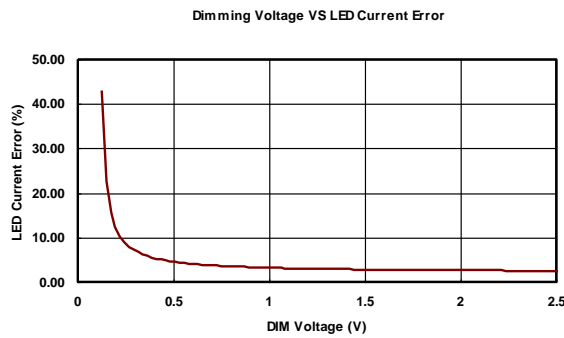
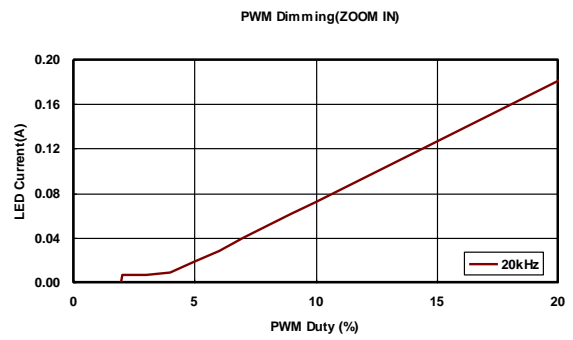
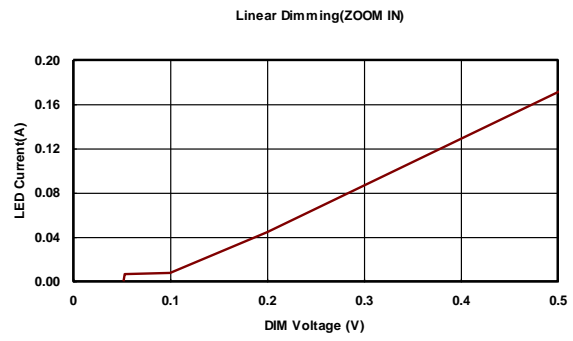
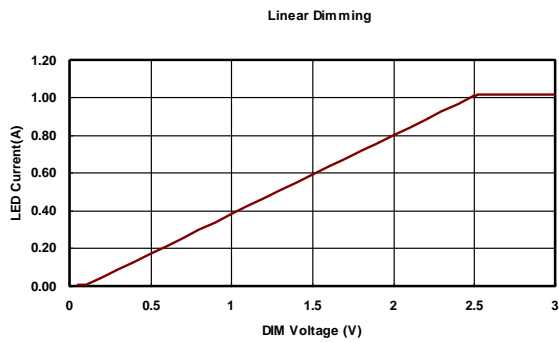

This datasheet contains new product information. Advanced Analog Technology reserves the rights to modify the product specification without notice. No liability is assumed as a result of the use of this product. No rights under any patent accompany the sales of the product.

Application Information

Inductor Selection

Inductance value is decided based on different condition. 68uH inductance value is recommended for general application circuit. There are three important inductor specifications, DC resistance, saturation current and core loss. Low DC resistance has better power efficiency.

The inductor current ripple ratio could be calculated by following equation:

$$\gamma = \frac{V_{IN} \times V_{LED} - V_{LED}^2}{f \times I_L \times L \times V_{IN}} , (I_L = I_{LED}, D = \frac{V_{LED}}{V_{IN}})$$

- ※ γ = inductor current ripple ratio
- ※ f = switch frequency
- ※ D = duty cycle

Capacitor Selection

The output capacitor is required to maintain the DC voltage during switching. Low ESR capacitors are preferred to reduce the output voltage ripple. Ceramic capacitor of X5R and X7R are recommended, which have low equivalent series resistance (ESR) and wider operation temperature range.

Diode Selection

Schottky diodes with fast recovery times and low forward voltages are recommended. Ensure the diode average and peak current rating exceed the average output current and peak inductor current. In addition, the diode's reverse breakdown voltage must exceed the input voltage.

OC resistor selection

FP7195 detect current when switch MOSFET turn on. The detect signal will add to slope compensation for FP7195 control loop stabled. OC resistor could be calculated by following equation:

$$R_{OC} = \frac{2 \times f \times L \times (2 \times V_{IN} - V_{LED})}{100 \times (2 \times f \times I_{LED} \times V_{IN} \times L + V_{LED} \times V_{IN} - V_{LED}^2)}$$

- ※ f = switch frequency
- ※ L = Inductor

Layout Considerations

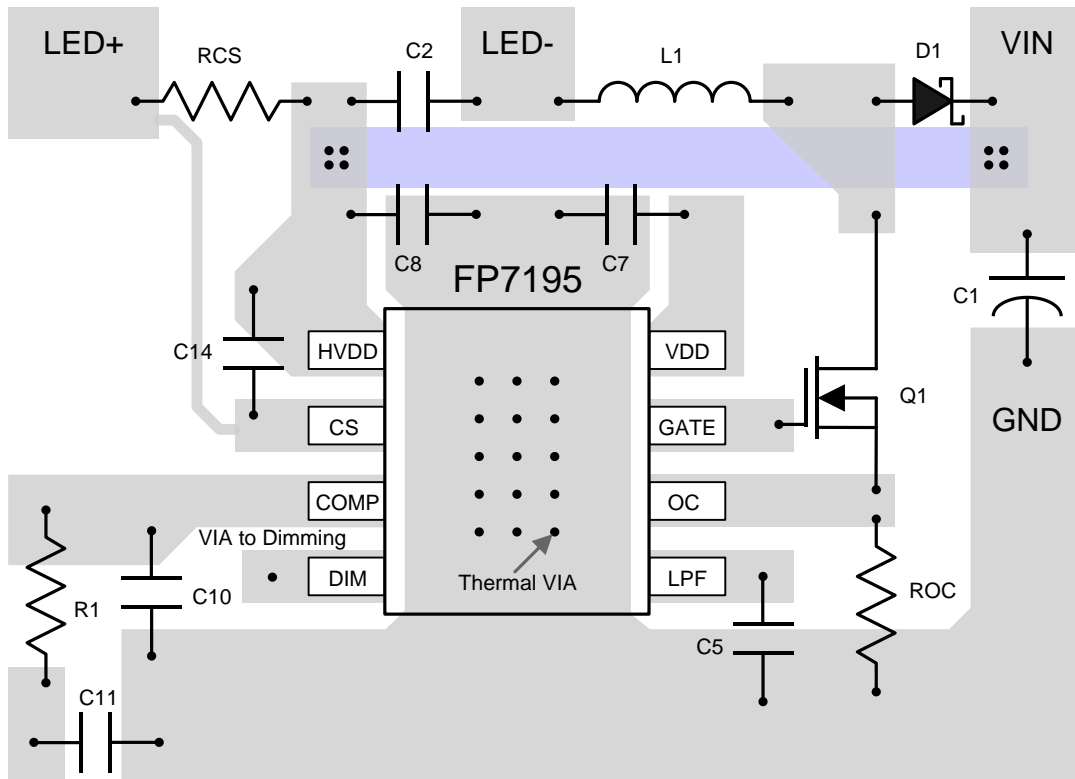

1. The power traces, consisting of the GND trace, the SW trace and the V_{IN} trace should be kept short, direct and wide.
2. Place C7 nearby VDD pin as closely as possible to maintain input voltage steady and filter noise.
3. CS and HVDD pin are the sensitive nodes. Please keep it away from switching node.
4. The GND of the C1、C7、C8 and IC's EP pad should be connected close and together directly to a ground plane. IC's EP pad should pour copper as large area as possible.
5. Place C8 nearby HVDD pin and IC's EP (GND pin) as closely as possible.

Typical Application Circuit

- Input voltage range = 12V ~ 80V
- Output LED voltage = 9V
- Output LED current = 1A

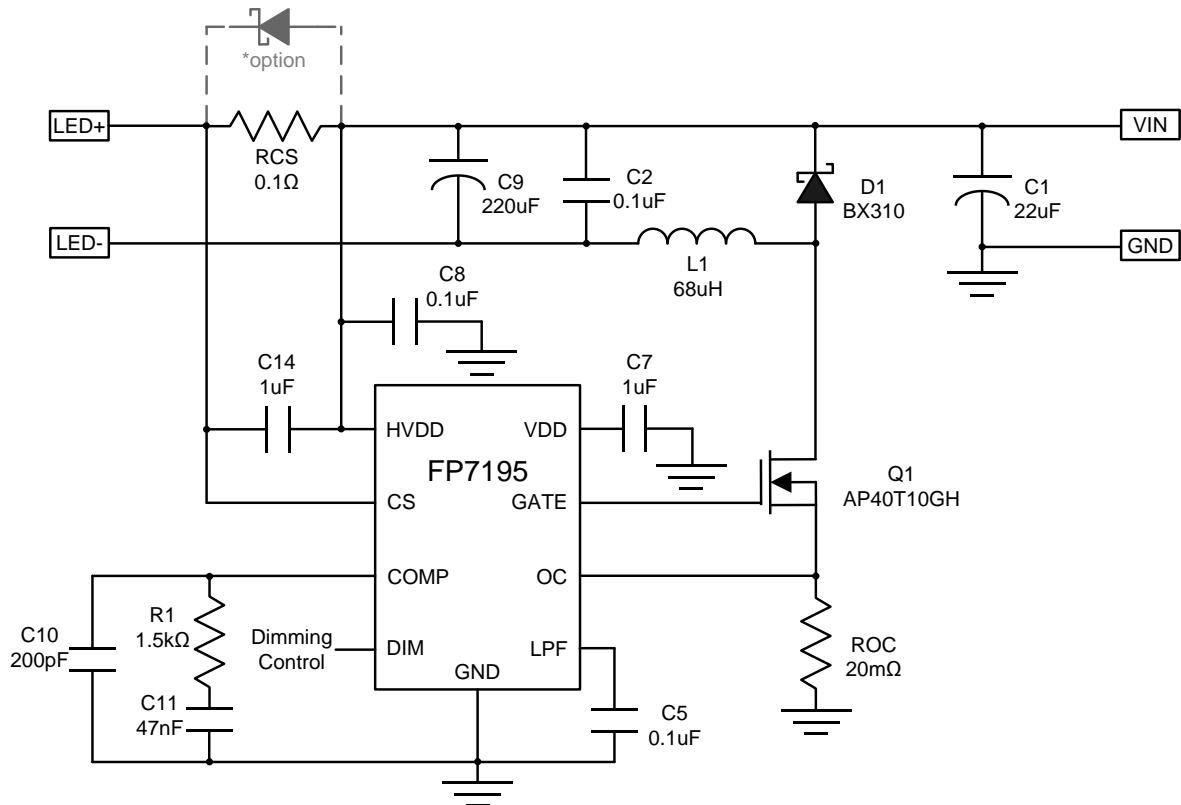

This datasheet contains new product information. Advanced Analog Technology reserves the rights to modify the product specification without notice. No liability is assumed as a result of the use of this product. No rights under any patent accompany the sales of the product.

Package Outline

SOP-8L (EP)

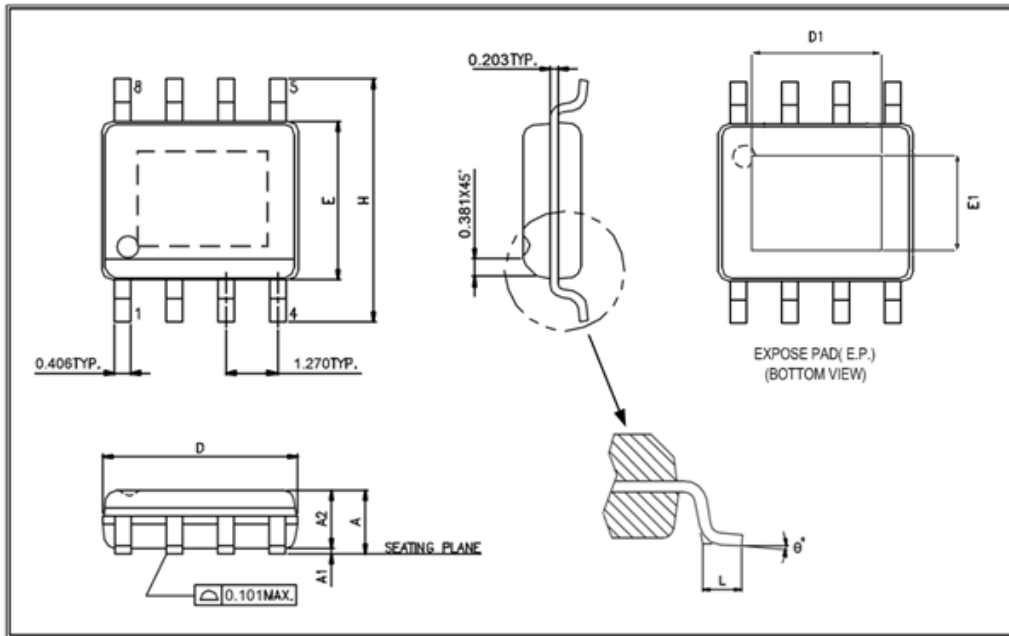

UNIT: mm

Symbols	Min. (mm)	Max. (mm)
A	1.346	1.752
A1	0.050	0.152
A2		1.498
D	4.800	4.978
E	3.810	3.987
H	5.791	6.197
L	0.406	1.270
θ°	0°	8°

Exposed PAD Dimensions:

Symbols	Min. (mm)	Max. (mm)
E1	2.05	2.41
D1	2.81	3.30

Note:

1. Package dimensions are in compliance with JEDEC outline: MS-012 AA.
2. Dimension "D" does not include molding flash, protrusions or gate burrs.
3. Dimension "E" does not include inter-lead flash or protrusions.

X-ON Electronics

Largest Supplier of Electrical and Electronic Components

Click to view similar products for [LED Display Drivers](#) category:

Click to view products by [Feeling](#) manufacturer:

Other Similar products are found below :

[STP16CPP05XTTR](#) [SCT2027CSSG](#) [KP22306WGA](#) [WS9088AS7P](#) [GN1628T](#) [BCT3236EGH-TR](#) [HT1628BRWZ](#) [KP1192SPA](#) [KP1182SPA](#)
[KP1262FSPA](#) [KP1072LSPA](#) [KP1191SPA](#) [KP18001WPA](#) [KP1221SPA](#) [GN1640T](#) [MBI5253GP-A](#) [MBI5124GM-B](#) [WS90561T](#) [S7P](#)
[WS9821B](#) [S7P](#) [WS9032GS7P](#) [LYT3315D](#) [M08888G-11](#) [M08890G-13](#) [BCR420U](#) [SCT2001ASIG](#) [SCT2024CSOG](#) [SCT2024CSSG](#)
[SCT2167CSSG](#) [AL8400QSE-7](#) [PR4401](#) [PR4403](#) [PCA9685PW](#) [STP16CPC05XTTR](#) [WS2821B](#) [PR4402](#) [M08898G-13](#) [RT8471GJ5](#)
[RT9284A-20GJ6E](#) [TLC59482DBQR](#) [ISL97634IRT14Z-TK](#) [AW36413CSR](#) [LP5562TMX](#) [DLD101Q-7](#) [WS2818B](#) [BCR401U](#) [BCR402U](#)
[SCT2004CSOG](#) [SCT2026CSSG](#) [SCT2026CSTG](#) [SCT2110CSSG](#)