

General Description

The FS177 is an integrated Hall effect latched sensor designed for electronic commutation of brush-less DC motor applications. The device includes an on-chip Hall voltage generator for magnetic sensing, a comparator that amplifies the Hall voltage, and a Schmitt trigger to provide switching hysteresis for noise rejection, and open-collector output. An internal bandgap regulator is used to provide temperature compensated supply voltage for internal circuits and allows a wide operating supply range.

A north pole of sufficient strength will turn the output ON. In the absence of a magnetic field, the output is OFF.

Features

- ◆ Wide operating voltage range: 3.0V to 20V
- ◆ Maximum output sink current 25mA
- ◆ Open-Collector pre-driver
- ◆ Reverse polarity protection
- ◆ Package : TO-92SP-3

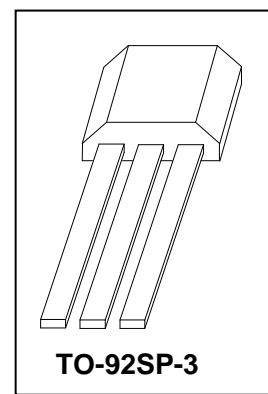

Typical Application Circuit

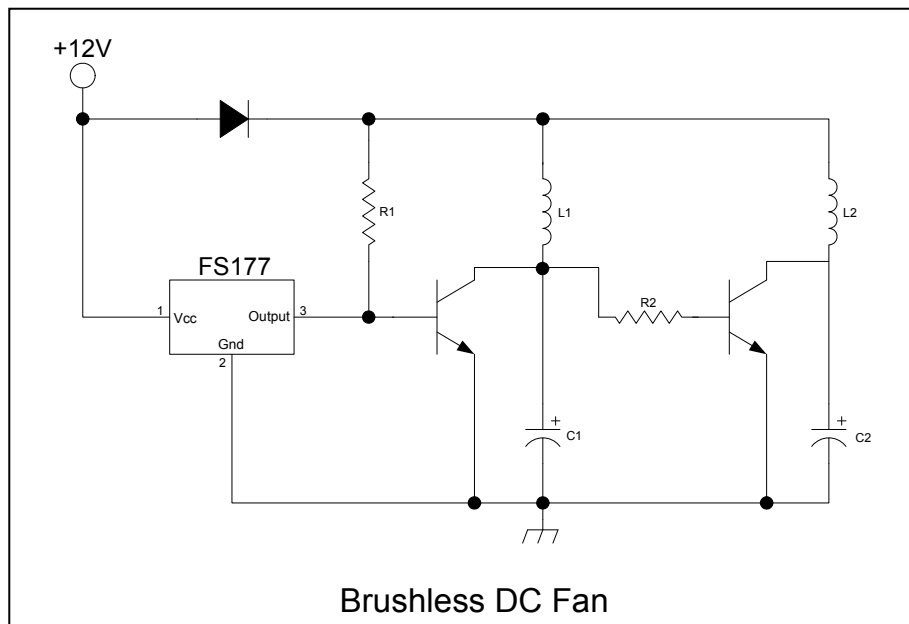

Functional Block Diagram

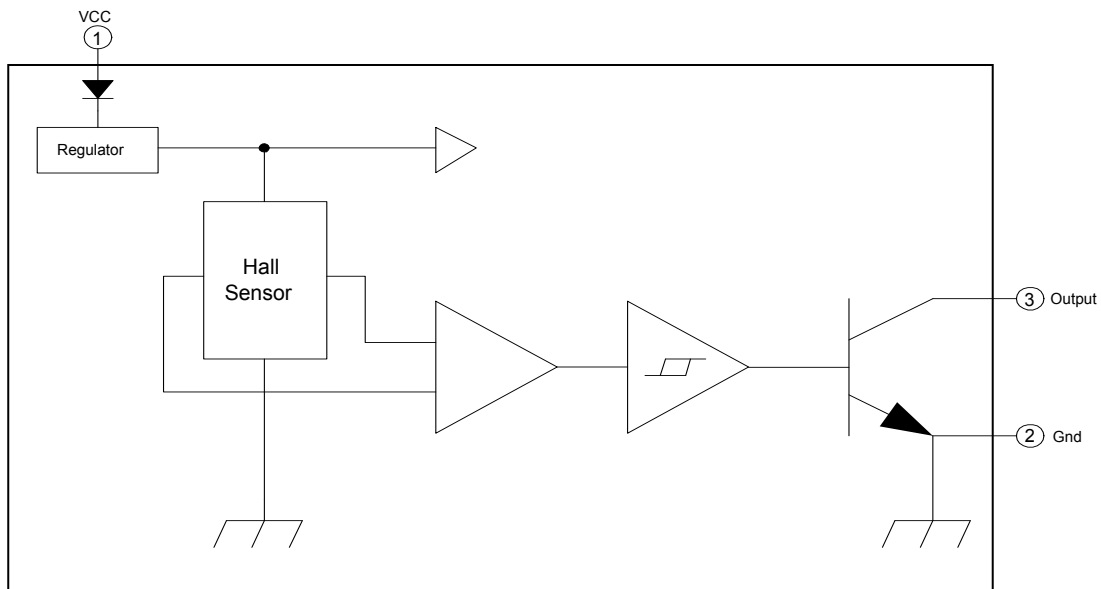

Mark View

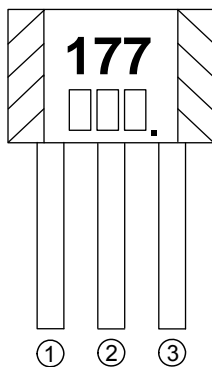

Pin Descriptions

NAME	NO.	STATUS	DESCRIPTION
VCC	1	P	IC Power Supply
GND	2	P	IC Ground
Output	3	O	It is low state during the N magnetic field.

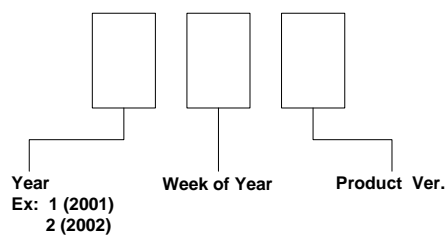

Absolute Maximum Ratings (at Ta = 25 °C)

VCC Pin Voltage -----	20V
Output OFF Voltage, Vce -----	20V
Output ON Current (Io)	
Continuous Current -----	25mA
Power Dissipation	
Ta=25 °C -----	400mW
Ta=100 °C -----	178mW
Thermal Resistance	
Θ_{ja} = -----	0.34 °C/mW
Θ_{jc} = -----	0.42 °C/mW
Operating Temperature Range -----	-20 °C to 100 °C
Storage Temperature Range -----	-65 °C to 150 °C
Junction Temperature -----	+160 °C
Lead Temperature (Soldering, 10 sec) -----	+260 °C

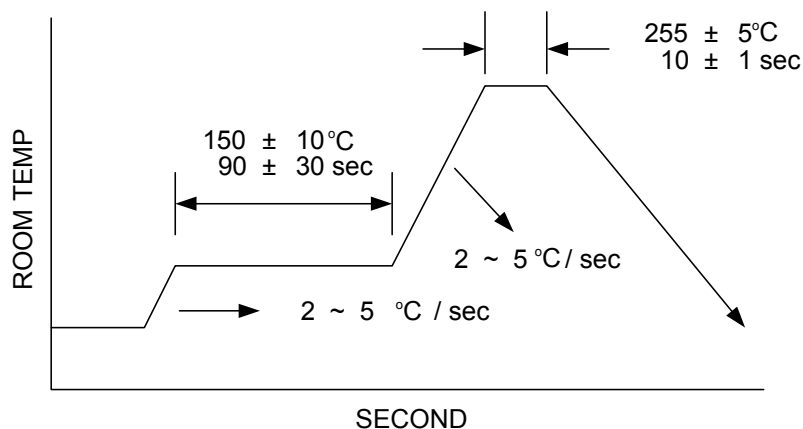

Soldering Condition

DC Electrical Characteristics (at Ta = 25 °C)

PARAMETER	SYMBOL	TEST CONDITIONS	MIN	TYP	MAX	UNIT
Operating Voltage	V _{CC}	No use pin is open (Fig1)	3.0	-	20.0	V
Supply current	I _{CC}	No use pin is open V _{CC} : 3.0V to 20V (Fig1)	-	4.2	10	mA
Output Saturation Voltage	V _{SAT}	V _{CC} =12V, I _o = 20mA	-	165	200	mV
Output Rise time	(t _r)	R _L =500ohm, C _L =20pF (Fig1)	0.2	-	0.75	uS
Output Fall time	(t _f)	R _L =500ohm, C _L =20pF (Fig1)	20	-	150	nS

Note: Fig1 The IC output state is under N magnetic field.

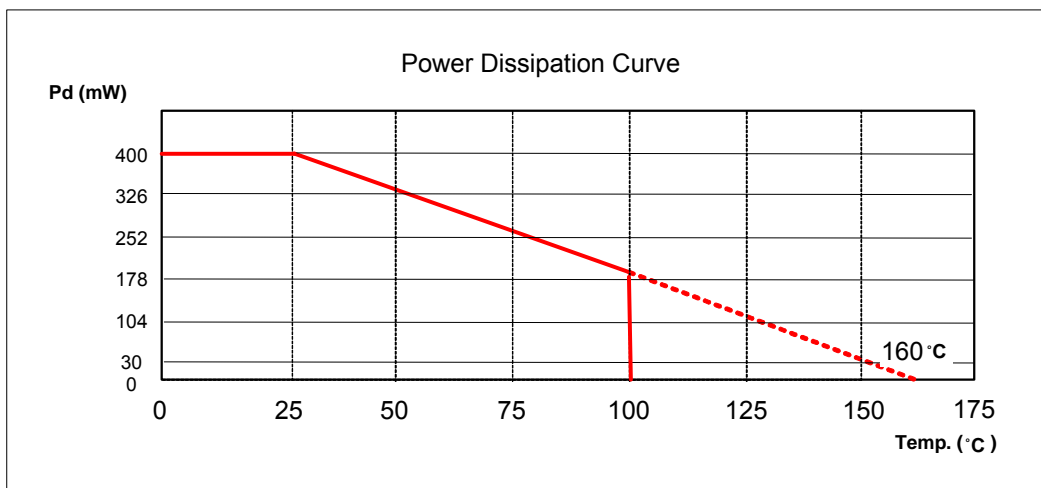

Magnetic Characteristics (1mT=10Gauss)

FS177LF- A		Ta = -20°C to 100°C			
Parameter	Symbol	Min.	Typ	Max.	Unit
Operate Point	Bop	+5	+35	+60	Gauss
Release Point	Brp	-60	-30	-5	Gauss
Hysteresis	Bhys	30		120	Gauss
FS177LF- B		Ta = -20°C to 100°C			
Parameter	Symbol	Min.	Typ	Max.	Unit
Operate Point	Bop	+5	-	+80	Gauss
Release Point	Brp	-80	-	-5	Gauss
Hysteresis	Bhys	30		120	Gauss
FS177LF- C		Ta = -20°C to 100°C			
Parameter	Symbol	Min.	Typ	Max.	Unit
Operate Point	Bop	-	-	+100	Gauss
Release Point	Brp	-100	-	-	Gauss
Hysteresis	Bhys	30		120	Gauss

FS177 Magnetic Hysteresis Characteristics Diagram:

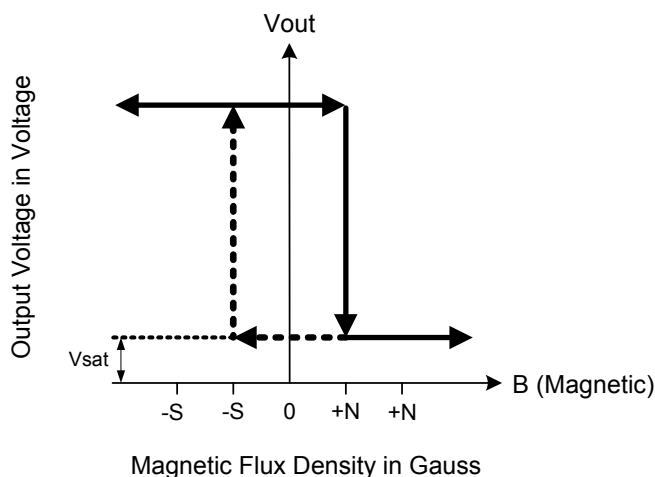

Test Circuits

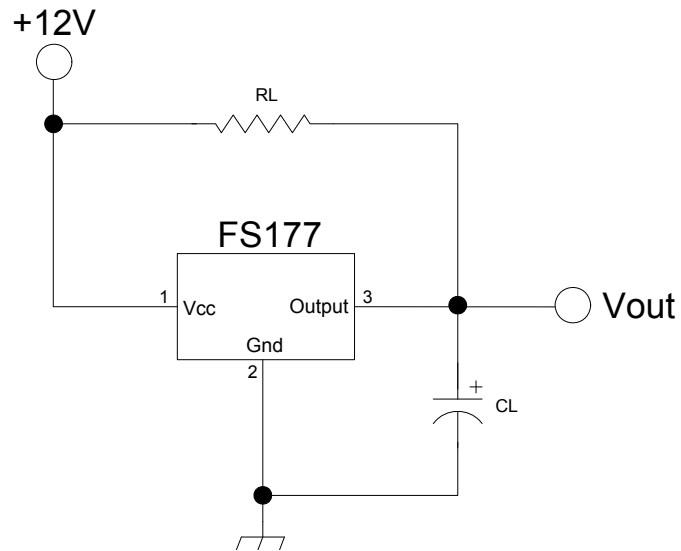

Fig 1

Typical Characteristics

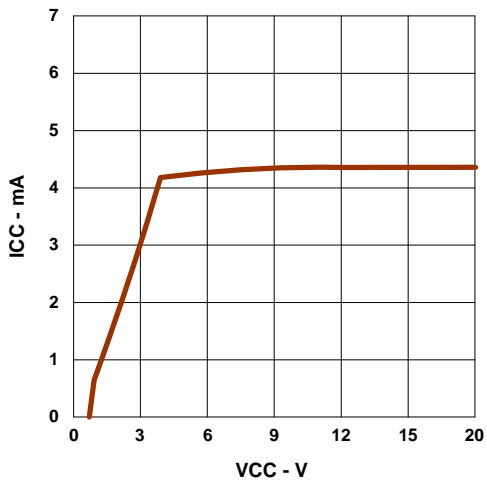

Figure 1

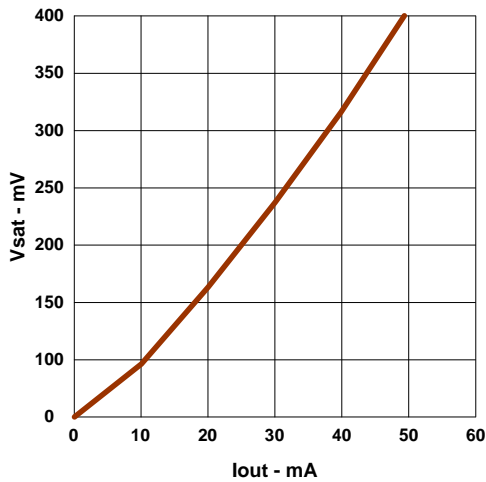

Figure 2

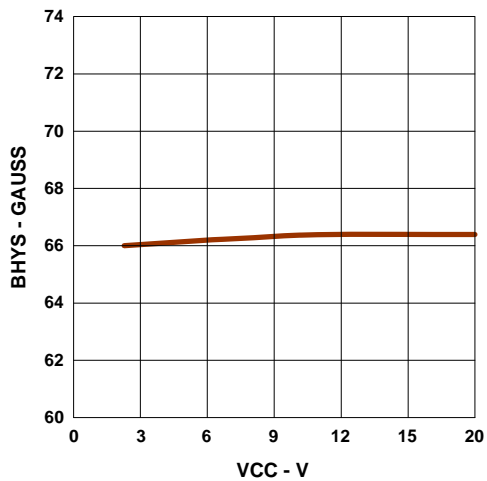

Figure 3

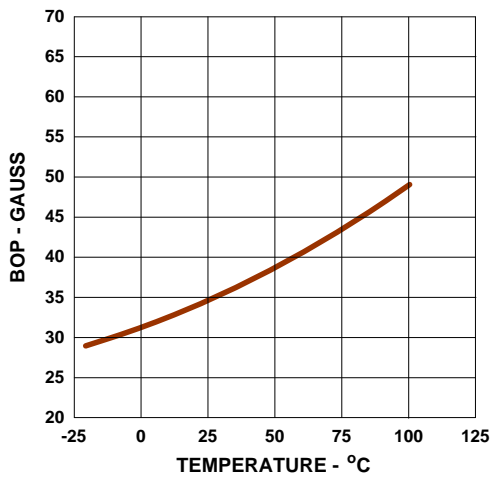

Figure 4

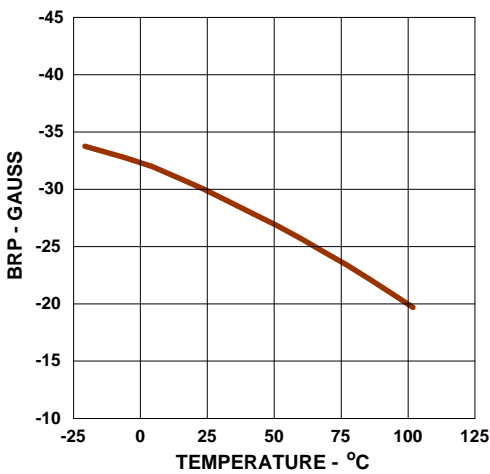

Figure 5

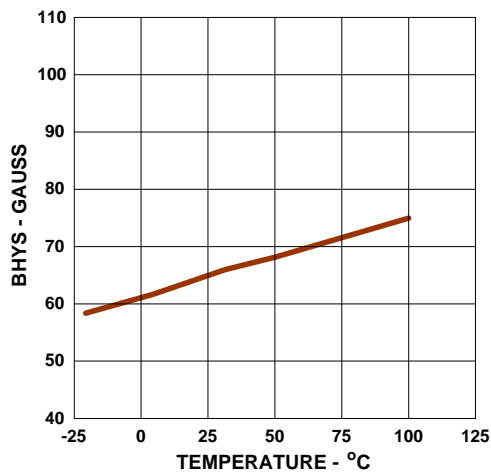

Figure 6

HALL SENSOR LOCATION

The Fig 2 is the hall sensor location, where marks the IC number.

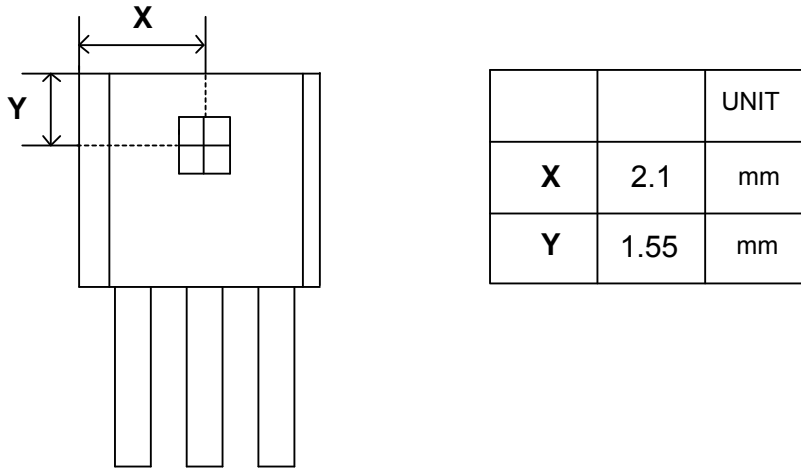
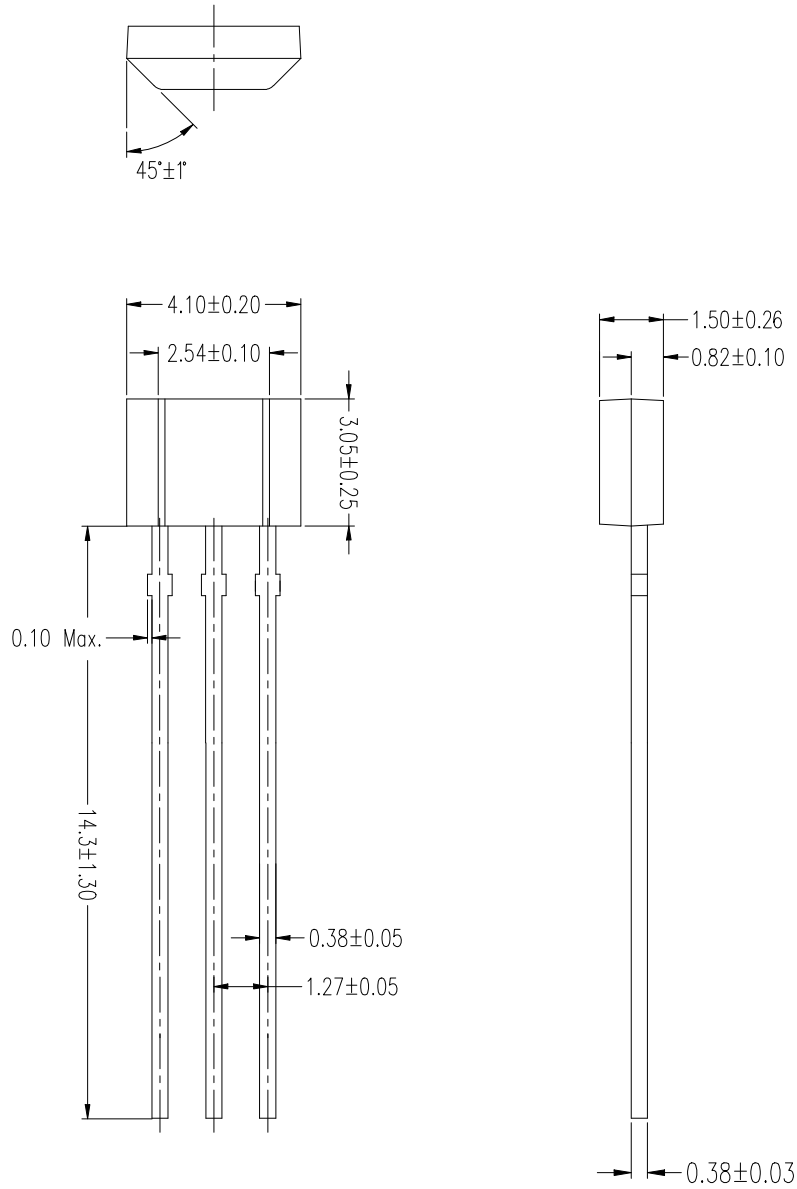
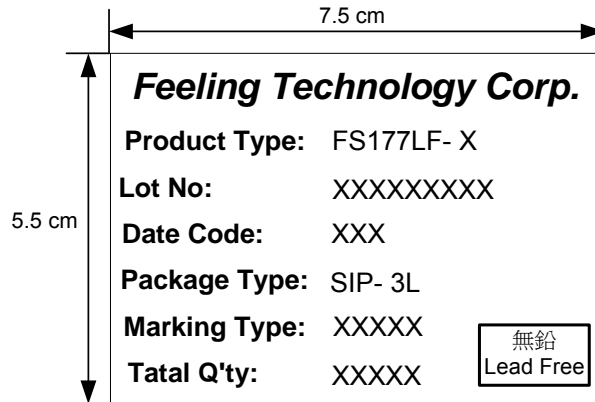

Fig 2 FS177 Hall Sensor Location

Package Outline (LEAD FREE)



LABEL SPECIFICATIONS



BAG LABEL, INSIDE BOX & CARTON LABEL

ORDER INFORMATION

Part Number	Operating Temperature	Package	Description
FS177LF- A	-20 °C to +100 °C	TO-92SP-3	± 60G (B)
FS177LF- B	-20 °C to +100 °C	TO-92SP-3	± 80G (B)
FS177LF- C	-20 °C to +100 °C	TO-92SP-3	±100G (B)

X-ON Electronics

Largest Supplier of Electrical and Electronic Components

Click to view similar products for [Industrial Hall Effect/Magnetic Sensors](#) category:

Click to view products by [Feeling manufacturer](#):

Other Similar products are found below :

[GT-14114](#) [GT-14123](#) [GTN2C15C](#) [GT-12076](#) [GT-14049](#) [GT-14067](#) [GT-14132](#) [GT-18030](#) [MZ07A108](#) [PST360G2-1S-C0000-ERA360-05K](#)
[MZC1-2V2PS-KP0](#) [PSC360G2-F1P-C0000-ERA360-05K-200](#) [115L 9E 502 W06017](#) [115L 5,2E 502 W06017](#) [115L 14E 502 W06017](#)
[103SR14A-1](#) [55100-3H-04-A](#) [MZT7-03VPS-KW0](#) [MZT8-03VPS-KW0](#) [A1326LLHLT-T](#) [ACS770LCB-100U-PFF-T](#) [55505-00-02-B](#) [GN](#)
[55.2-ND-15-3](#) [GN 55.2-ND-18-3](#) [GN 55.2-ND-4-3](#) [GN 55.2-ND-8-3](#) [GN 55.2-SC-10-3](#) [GN 55.4-ND-10-7,5-2](#) [GN 55.4-ND-12-9,5-2,5](#) [GN](#)
[55.4-ND-26-20,3-5](#) [GN 55.4-ND-7,5-4-1,5](#) [101MG7-BP](#) [103SR18-1](#) [A1324LUA-T](#) [MXM1120KIT](#) [MXM1120SOKIT](#) [AA006-02E](#) [55140-](#)
[3H-03-A](#) [55100-2M-02-A](#) [MM12-60APS-ZUK](#) [ACX04-F99-I-V15](#) [GN 55.1-SC-24-11.5-4](#) [MZA70155](#) [MZR40158](#) [PW520000](#) [MZT7-](#)
[03VPS-KP0](#) [MZT8-03VPS-KR0](#) [MZT8-03VPS-KP0](#) [RZT7-03ZRS-KP0](#) [RZT7-03ZRS-KW0](#)