



N 沟道增强型场效应晶体管

N-CHANNEL MOSFET

FHF4N90A

主要参数 MAIN CHARACTERISTICS

| | |
|-----------------------|--------|
| ID | 4A |
| VDSS | 900V |
| Rdson-typ (@Vgs=10V) | 2.6Ω |
| Qg-typ | 25.2nC |

产品特性 FEATURES

| | |
|--------------------|---------------------------|
| 低栅极电荷 | Low gate charge |
| 低 Crss (典型值 7.4pF) | Low Crss (typical 7.4pF) |
| 开关速度快 | Fast switching |
| 100%经过雪崩测试 | 100% avalanche tested |
| 高抗 dv/dt 能力 | Improved dv/dt capability |
| RoHS 产品 | RoHS product |

用途 APPLICATIONS

| | |
|--------|--|
| 高频开关电源 | High efficiency switch mode power supplies |
| LED电源 | LED Power |

封装形式 Package



等效电路 Equivalent Circuit

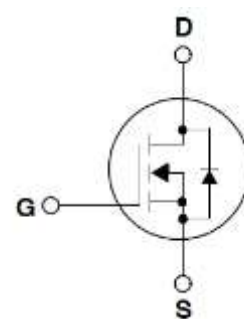

绝对最大额定值 ABSOLUTE RATINGS (Tc=25°C)

| 项目 Parameter | 符号 Symbol | 数值 Value | 单位 Unit |
|---|--------------------|-----------------|------------|
| | | FHF4N90A | |
| 最高漏极-源极直流电压 Drain-Source Voltage | VDS | 900 | V |
| 连续漏极电流* Drain Current -continuous * | ID (TC=25°C) | 4 | A |
| | ID (TC=100°C) | 2.5 | A |
| 最大脉冲漏极电流 (注 1) Drain Current – pulse (note 1) | IDM | 16 | A |
| 最高栅源电压 Gate-Source Voltage | VGS | ±30 | V |
| 单脉冲雪崩能量 (注 2) Single Pulsed Avalanche Energy (note 2) | EAS | 150 | mJ |
| 雪崩电流 (注 1) Avalanche Current (note 1) | IAR | 3.3 | A |
| 重复雪崩能量 (注 1) Repetitive Avalanche Current (note 1) | EAR | 5.5 | mJ |
| 二极管反向恢复最大电压变化速率 (注 3) Peak Diode Recovery dv/dt (note 3) | dv/dt | 5.0 | V/ns |
| 耗散功率 Power Dissipation | PD (TC=25°C) | 35 | W |
| | -Derate above 25°C | 0.28 | W/°C |
| 最高结温及存储温度 Operating and Storage Temperature Range | TJ, TSTG | 150, -55 to 150 | °C |
| 引线最高焊接温度 Maximum Lead Temperature for Soldering Purposes | TL | 300 | °C |

*漏极电流由最高结温限制

*Drain current limited by maximum junction temperature

电特性 ELECTRICAL CHARACTERISTICS

| 项目 Parameter | 符号 Symbol | 测试条件 Tests conditions | 最小 Min | 典型 Typ | 最大 Max | 单位 Units |
|--|-------------------------------------|---|-----------|-----------|-----------|-------------|
| 关态特性 Off –Characteristics | | | | | | |
| 漏-源击穿电压 Drain-Source Voltage | BV _{DSS} | I _D =250μA, V _{GS} =0V | 900 | - | - | V |
| 击穿电压温度特性 Breakdown Voltage Temperature Coefficient | ΔBV _{DSS} /ΔT _J | I _D =250μA, referenced to 25°C | - | 0.92 | - | V/°C |
| 零栅压下漏极漏电流 Zero Gate Voltage Drain Current | I _{DSS} | V _{DS} =900V, V _{GS} =0V, T _C =25°C | - | - | 1 | μA |
| | | V _{DS} =720V, T _C =125°C | - | - | 100 | μA |
| 栅极体漏电流 Gate-body leakage current | I _{GSS} (F/R) | V _{DS} =0V, V _{GS} =±30V | - | - | ±100 | nA |
| 通态特性 On-Characteristics | | | | | | |
| 阈值电压 Gate Threshold Voltage | V _{GS(th)} | V _{DS} = V _{GS} , I _D =250μA | 2.0 | - | 4.0 | V |
| 静态导通电阻 Static Drain-Source On-Resistance | R _{DS(ON)} | V _{GS} =10V , I _D =2A | - | 2.6 | 3.0 | Ω |
| 正向跨导 Forward Transconductance | g _{fs} | V _{DS} = 15V, I _D =2A (note 4) | - | 5 | - | S |
| 动态特性 Dynamic Characteristics | | | | | | |
| 输入电容 Input capacitance | C _{iss} | V _{DS} =25V, V _{GS} =0V, f=1.0MHz | - | 835 | - | pF |
| 输出电容 Output capacitance | C _{oss} | | - | 76 | - | |
| 反向传输电容 Reverse transfer capacitance | C _{rss} | | - | 7.4 | - | |
| 开关特性 Switching Characteristics | | | | | | |
| 延迟时间 Turn-On delay time | t _{d(on)} | V _{DS} =450V, I _D =4A, R _G =10Ω V _{GS} =10V (note 4, 5) | - | 16 | - | ns |
| 上升时间 Turn-On rise time | t _r | | - | 17 | - | ns |
| 延迟时间 Turn-Off delay time | t _{d(off)} | | - | 43 | - | ns |
| 下降时间 Turn-Off Fall time | t _f | | - | 14 | - | ns |
| 栅极电荷总量 Total Gate Charge | Q _g | V _{DS} =720V , I _D =4A , V _{GS} =10V (note 4, 5) | - | 25.2 | - | nC |
| 栅-源电荷 Gate-Source charge | Q _{gs} | | - | 4 | - | nC |
| 栅-漏电荷 Gate-Drain charge | Q _{gd} | | - | 12.2 | - | nC |
| 漏-源二极管特性及最大额定值 Drain-Source Diode Characteristics and Maximum Ratings | | | | | | |
| 正向最大连续电流 Maximum Continuous Drain-Source Diode Forward Current | | I _S | - | - | 4 | A |
| 正向最大脉冲电流 Maximum Pulsed Drain-Source Diode Forward Current | | I _{SM} | - | - | 16 | A |
| 正向压降 Drain-Source Diode Forward Voltage | V _{SD} | V _{GS} =0V, I _S =4A | - | - | 1.4 | V |
| 反向恢复时间 Reverse recovery time | t _{rr} | V _{GS} =0V, I _S =4A ,dI _F /dt=100A/μs (note 4) | - | 382 | - | ns |
| 反向恢复电荷 Reverse recovery charge | Q _{rr} | | - | 1.79 | - | μC |

热特性 THERMAL CHARACTERISTIC

| 项目 Parameter | 符号 Symbol | FHF4N90A | 单位 Unit |
|--|--------------|----------|------------|
| 结到管壳的热阻 Thermal Resistance, Junction to Case | Rth(j-c) | 3.57 | °C/W |
| 结到环境的热阻 Thermal Resistance, Junction to Ambient | Rth(j-A) | 62.5 | °C/W |

注释:

- 1: 脉冲宽度由最高结温限制
- 2: L=10mH, IAS=5.5A, VDD=50V, RG=25 Ω, 起始结温 TJ=25°C
- 3: ISD ≤4A, di/dt ≤100A/μs, VDD≤BV_{DSS}, 起始结温 TJ=25°C
- 4: 脉冲测试: 脉冲宽度 ≤300μs, 占空比≤2%
- 5: 基本与工作温度无关

Notes:

- 1: Pulse width limited by maximum junction temperature
- 2: L=10mH, IAS=5.5A, VDD=50V, RG=25 Ω, Start TJ=25°C;
- 3: ISD ≤4A, di/dt ≤100A/μs, VDD≤BV_{DSS}, Starting TJ=25°C
- 4: Pulse Test: Pulse Width ≤300μs, Duty Cycle≤2%
- 5: Essentially independent of operating temperature

特性曲线

(ELECTRICAL CHARACTERISTICS CURVES)

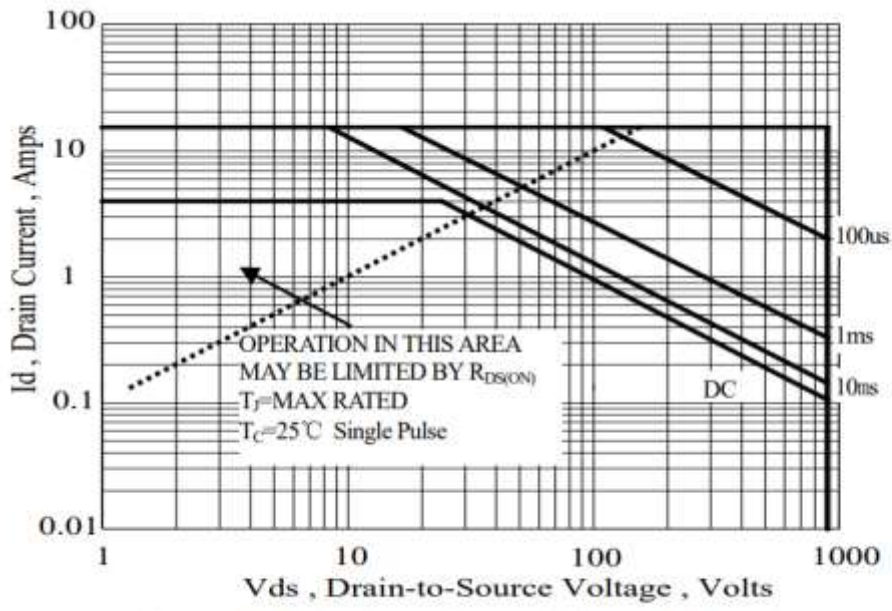

Figure 1 Maximum Forward Bias Safe Operating Area

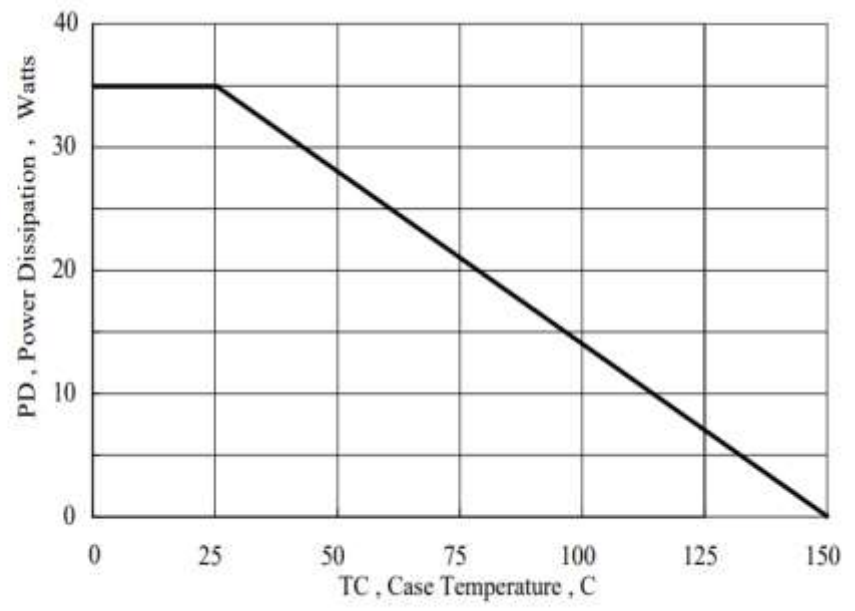

Figure 2 Maximum Power Dissipation vs Case Temperature

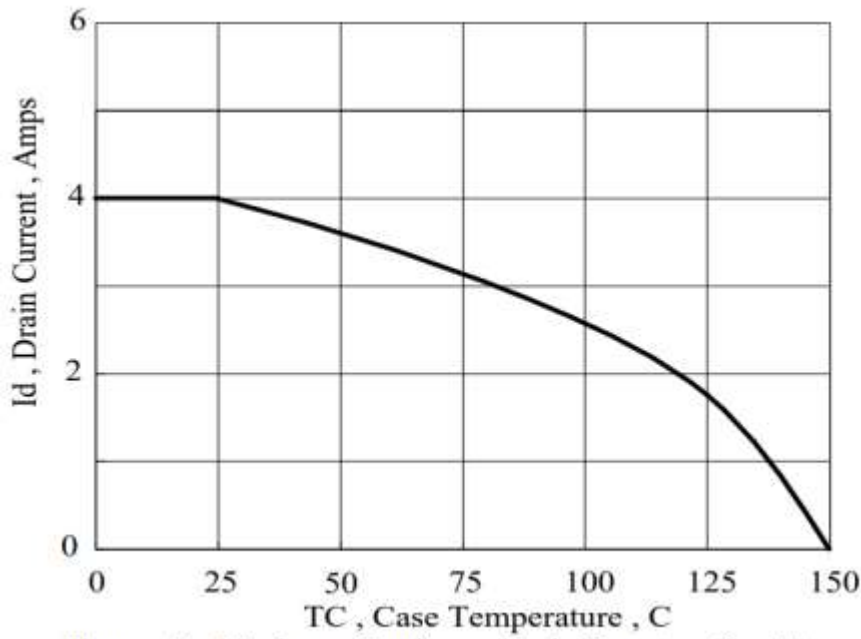

Figure 3 Maximum Continuous Drain Current vs Case Temperature

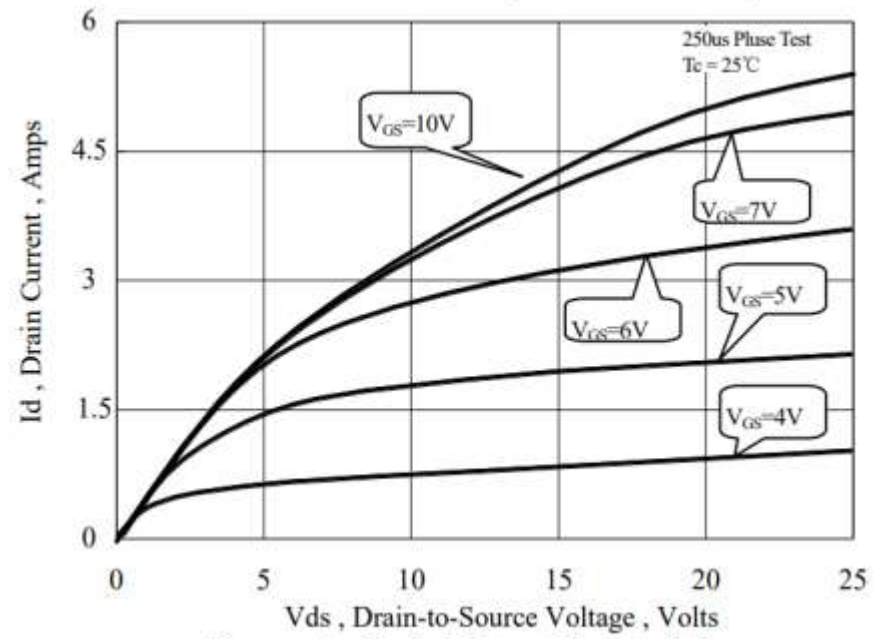

Figure 4 Typical Output Characteristics

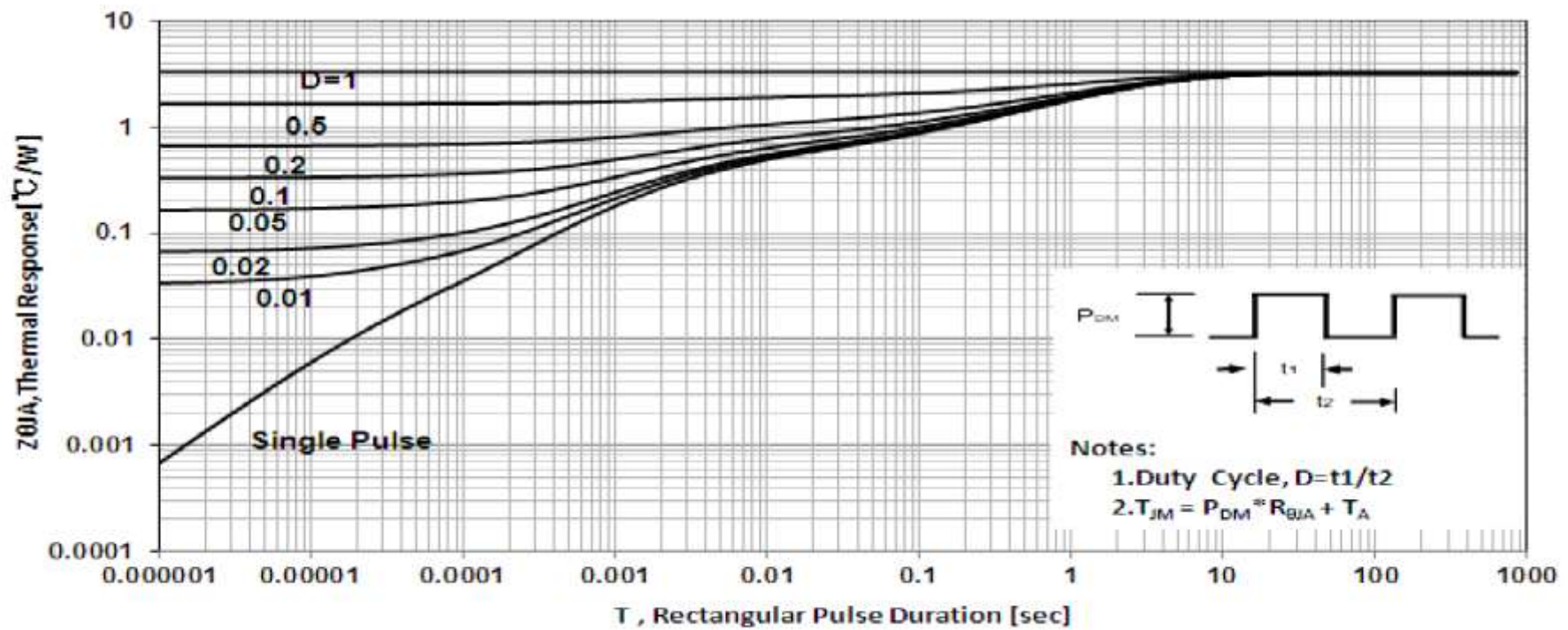

Figure 5 Maximum Effective Thermal Impedance, Junction to Case

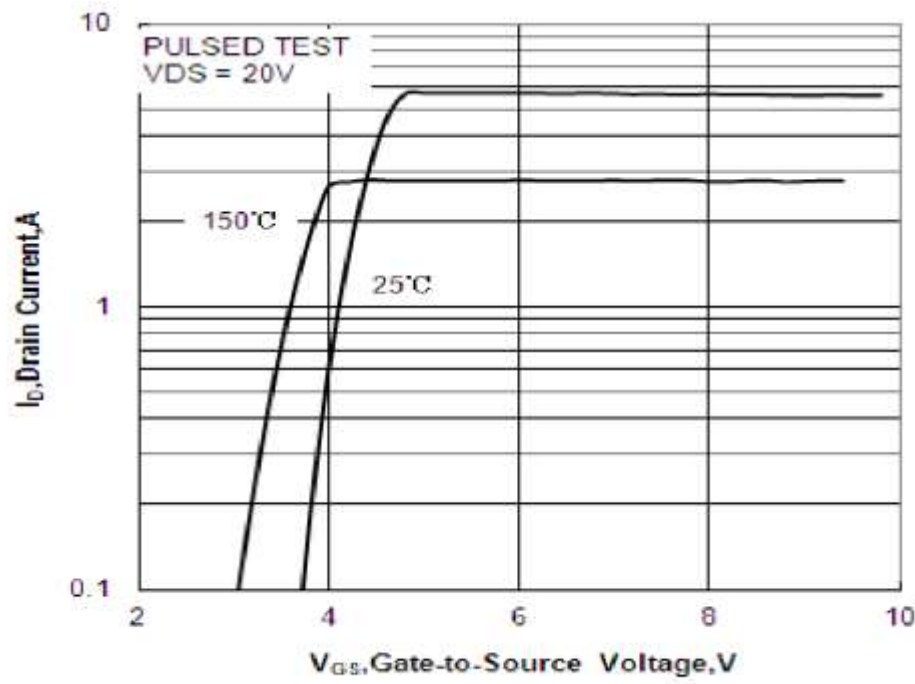

Figure 6 Typical Transfer Characteristics

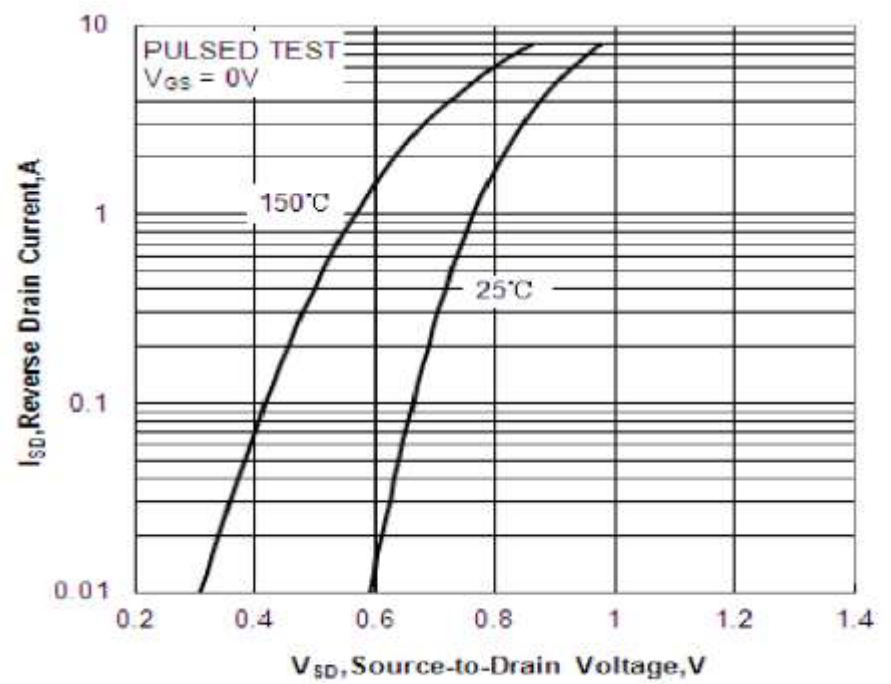

Figure 7 Typical Body Diode Transfer Characteristics

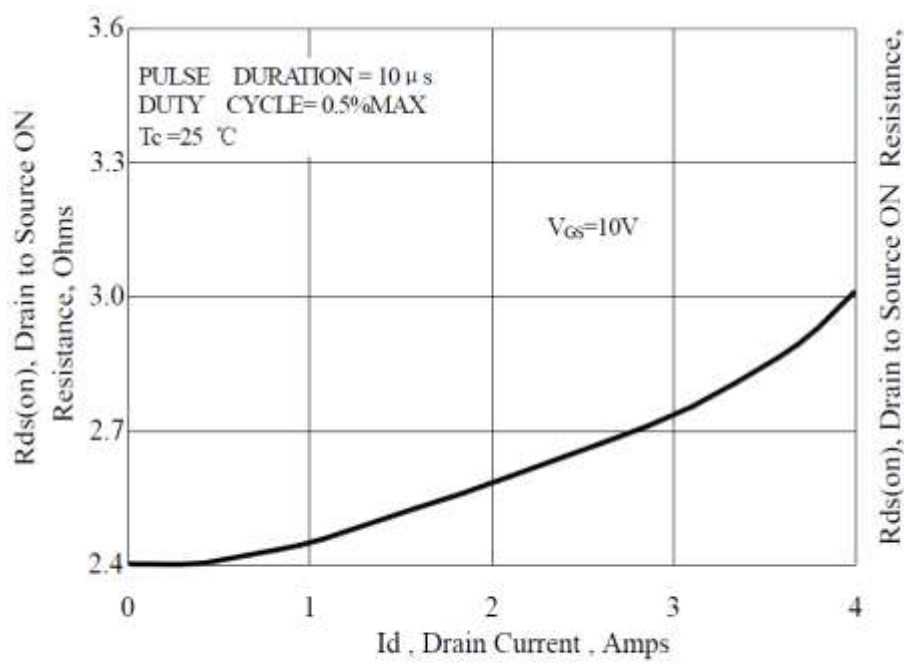

Figure 8 Typical Drain to Source ON Resistance vs Drain Current

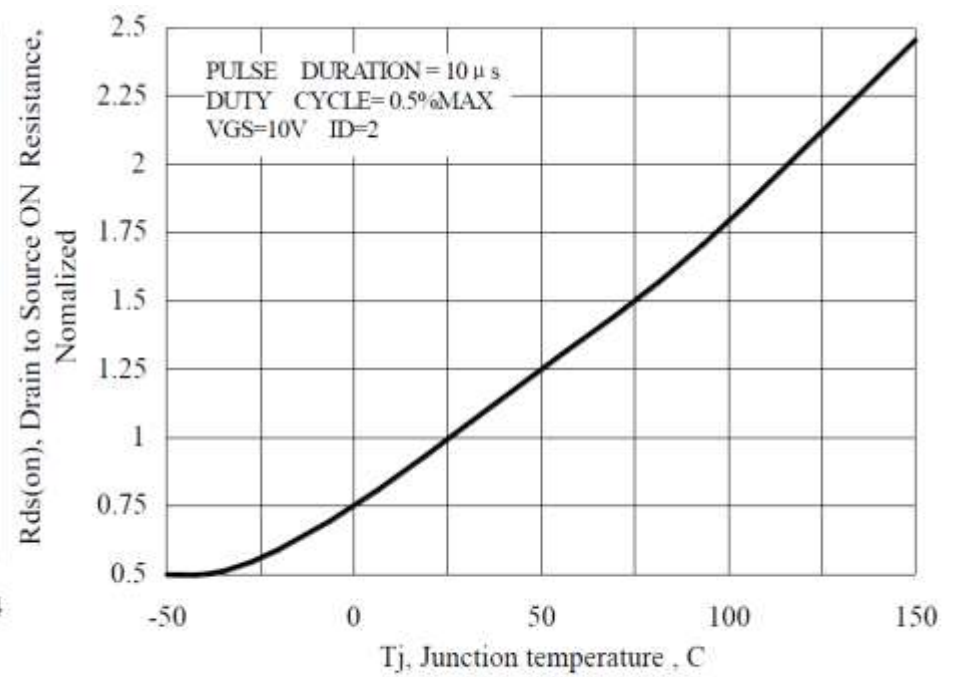

Figure 9 Typical Drain to Source on Resistance vs Junction Temperature

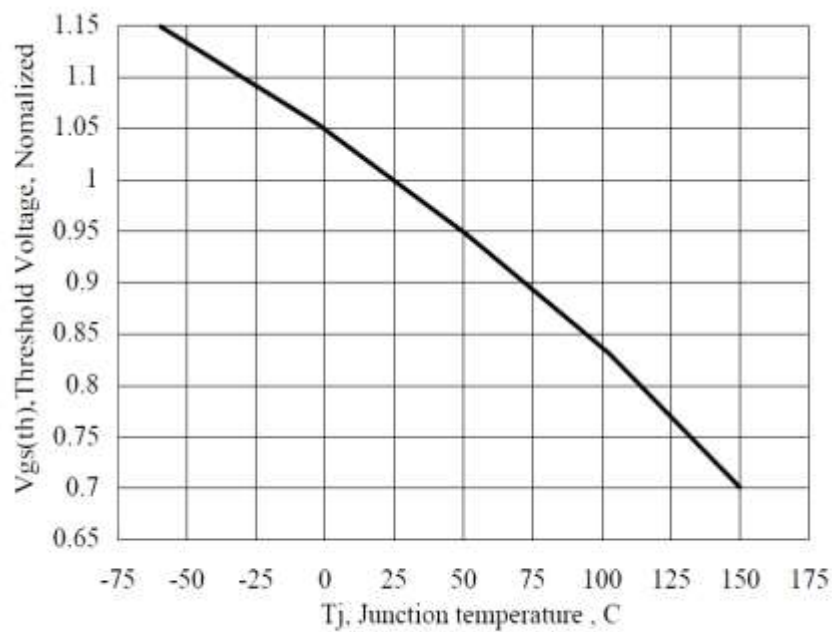

Figure 10 Typical Threshold Voltage vs Junction Temperature

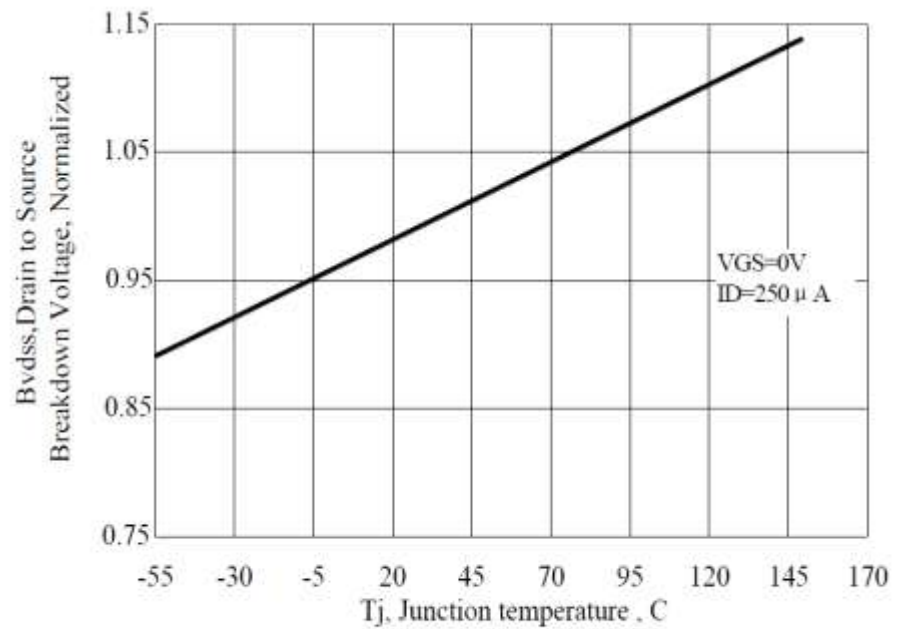

Figure 11 Typical Breakdown Voltage vs Junction Temperature

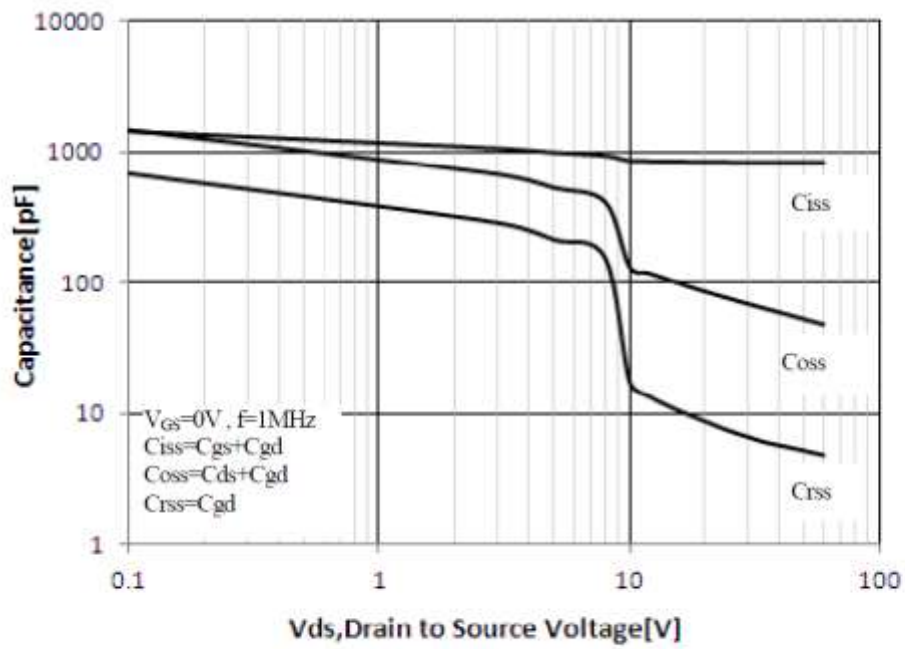

Figure 12 Typical Capacitance vs Drain to Source Voltage

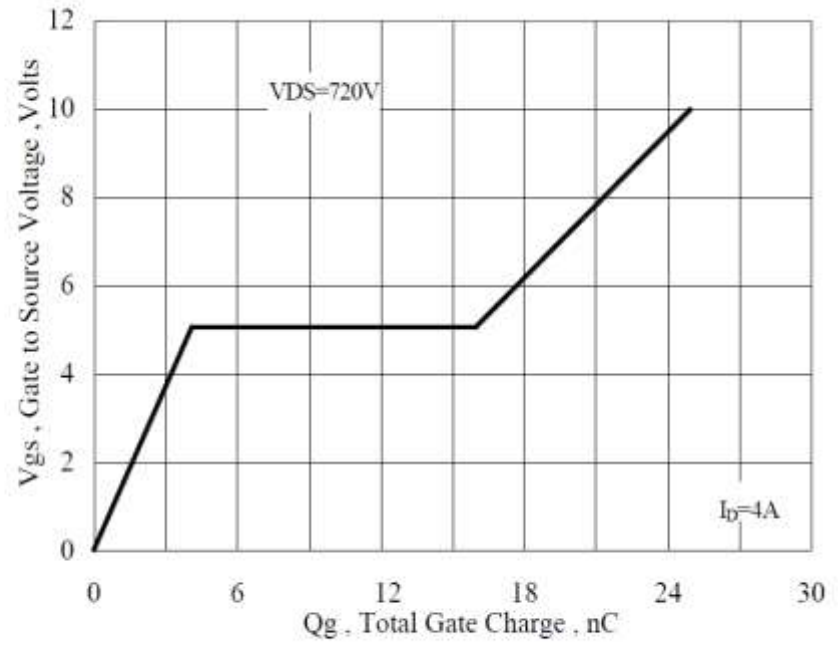

Figure 13 Typical Gate Charge vs Gate to Source Voltage

Test Circuit and Waveform

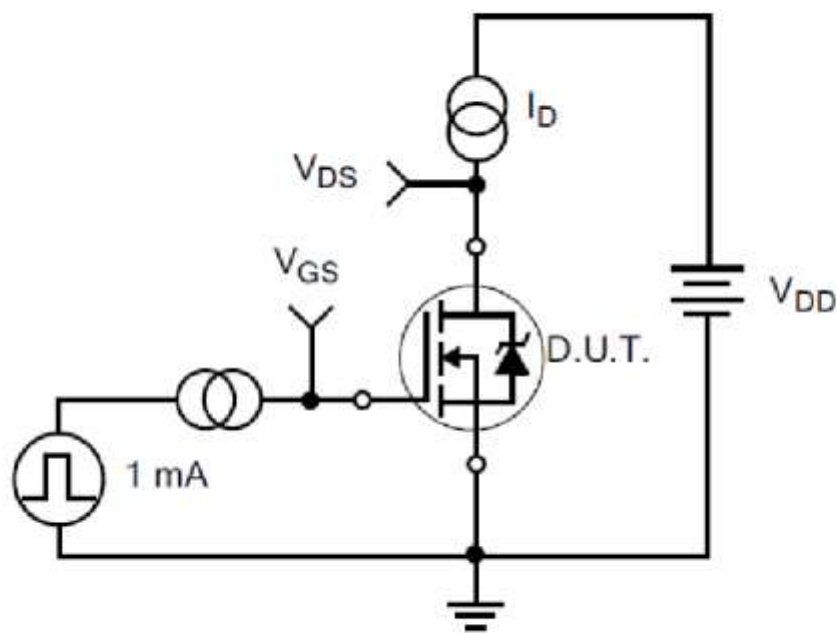

Figure 14. Gate Charge Test Circuit

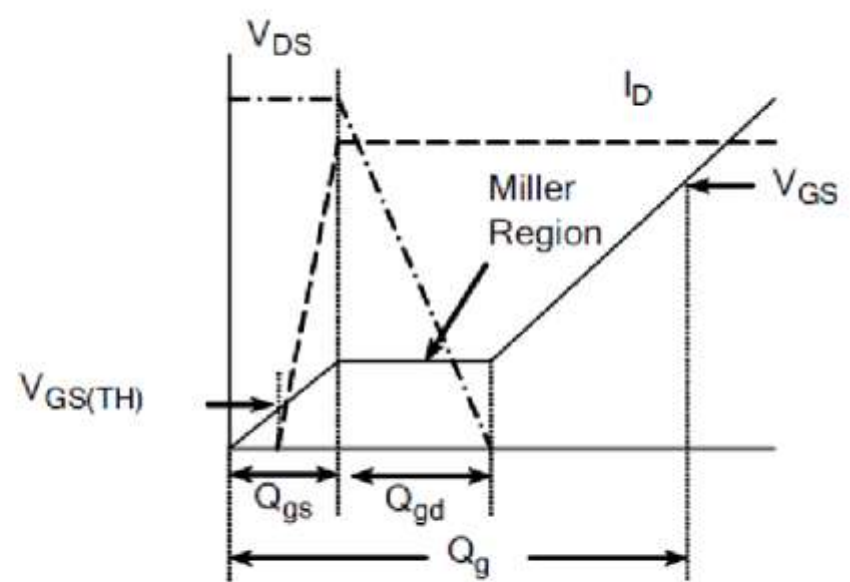

Figure 15. Gate Charge Waveforms

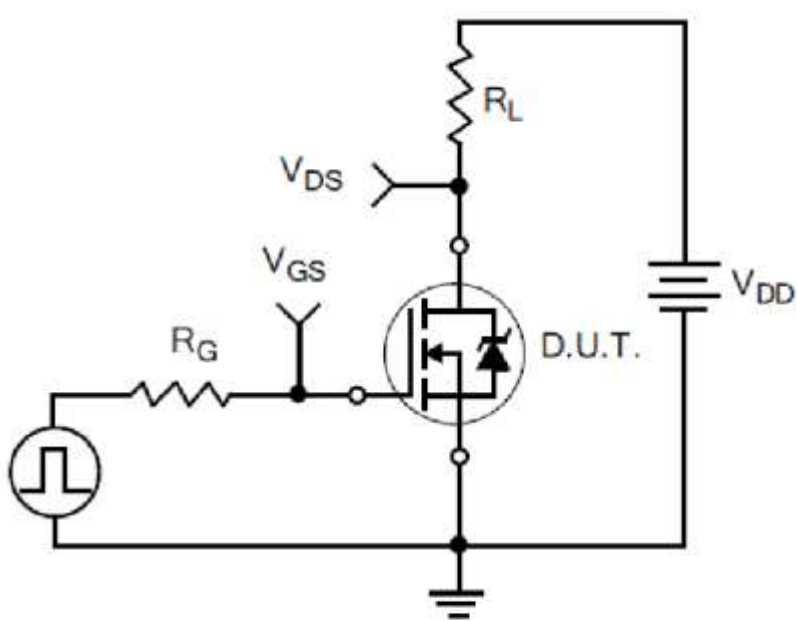

Figure 16. Resistive Switching Test Circuit

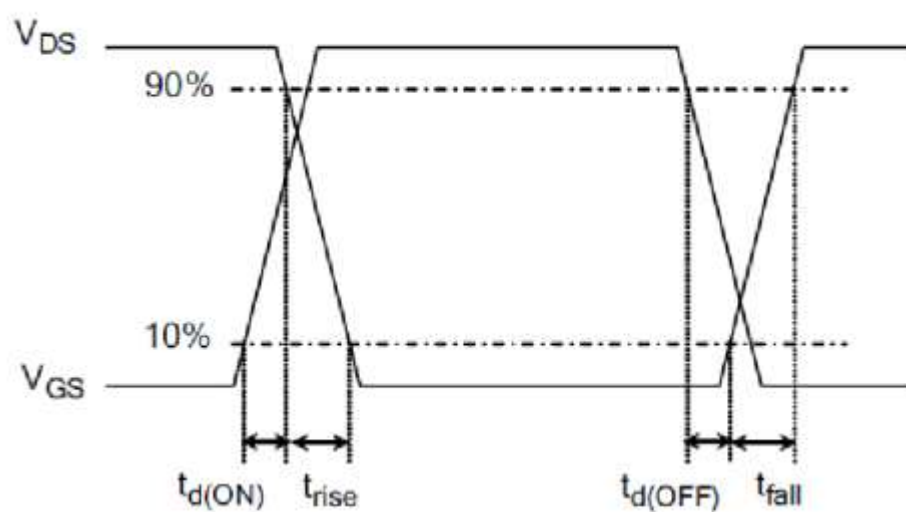

Figure 17. Resistive Switching Waveforms

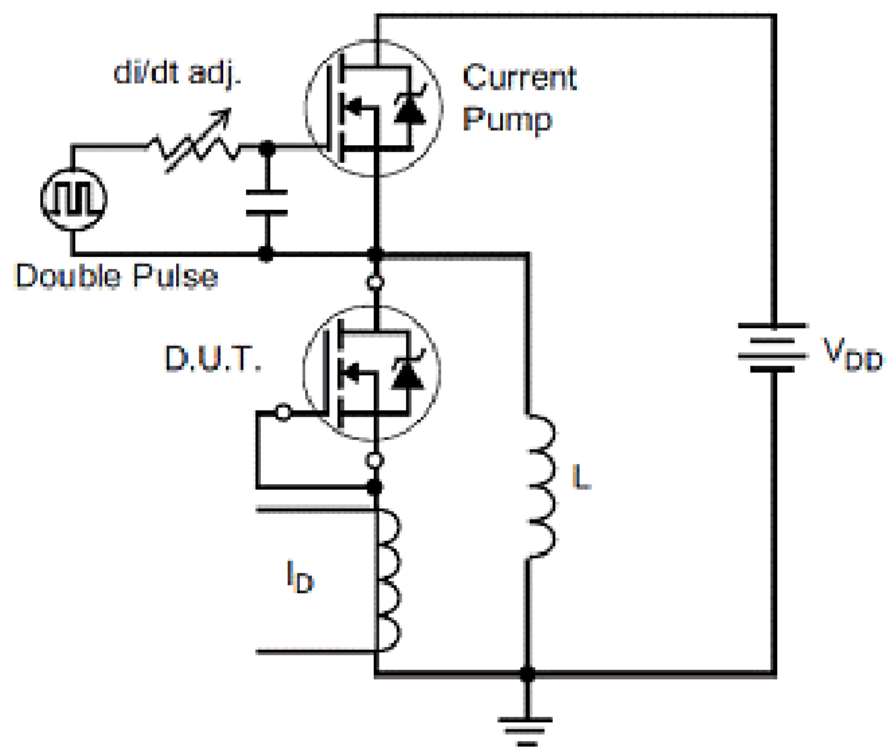

Figure 18. Diode Reverse Recovery Test Circuit

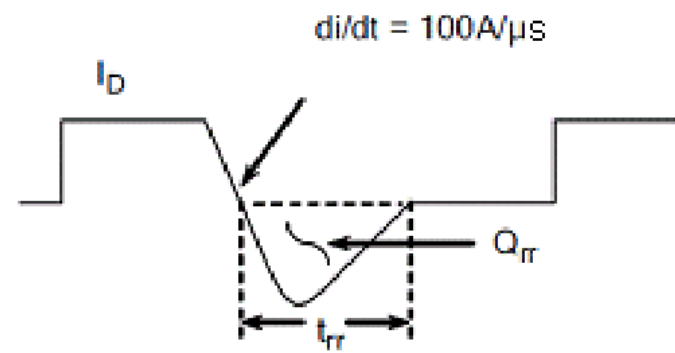

Figure 19. Diode Reverse Recovery Waveform

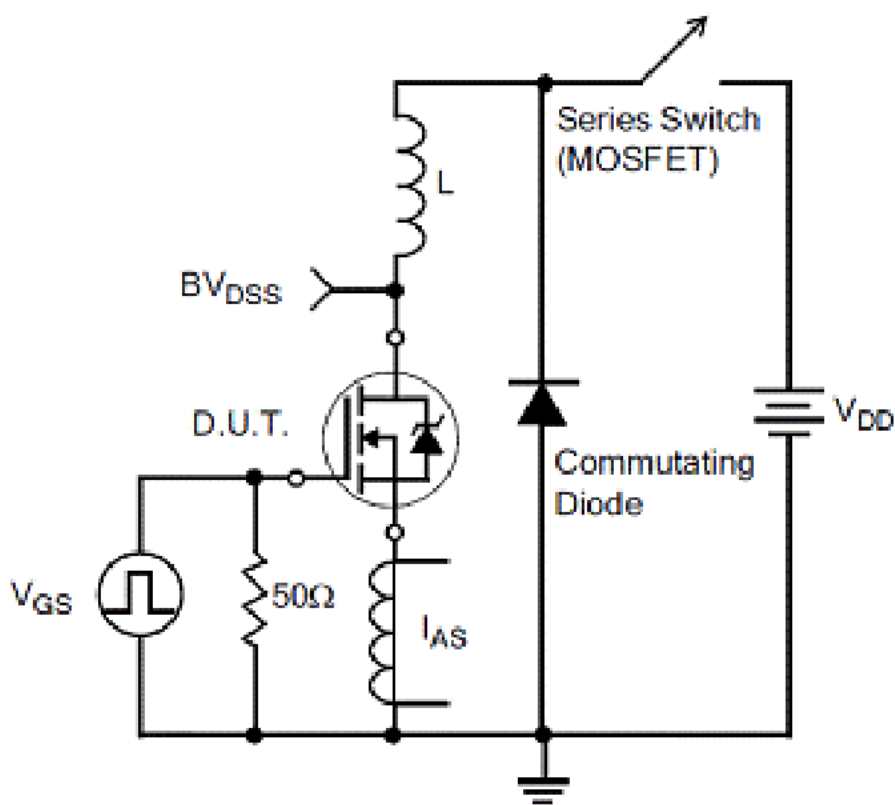

Figure20.Unclamped Inductive Switching Test Circuit

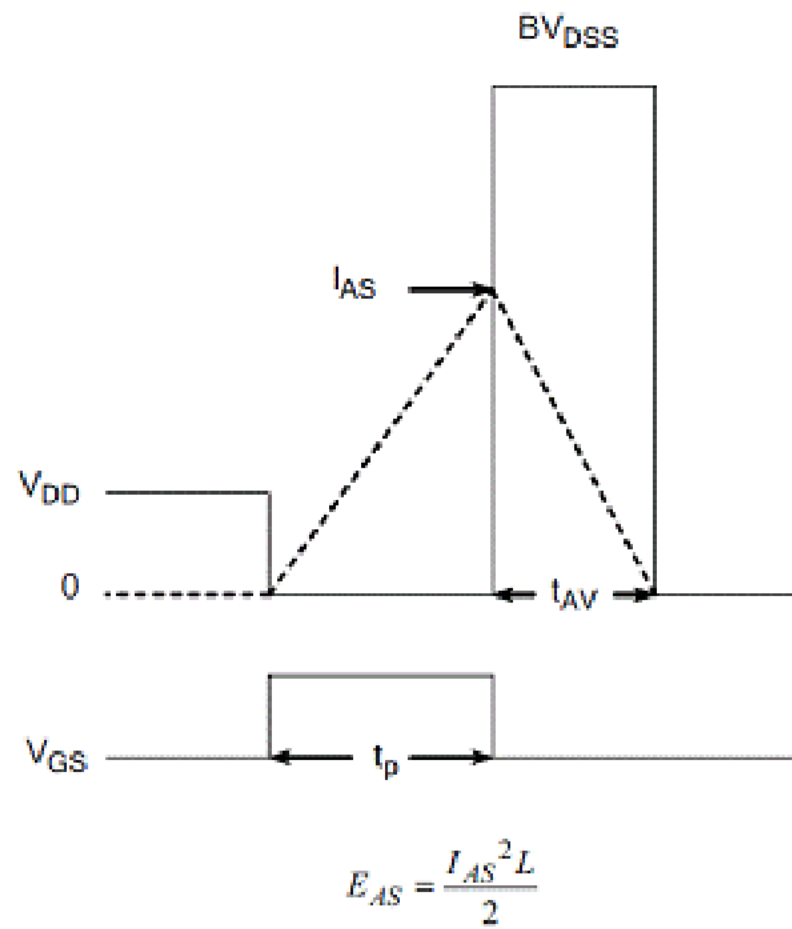
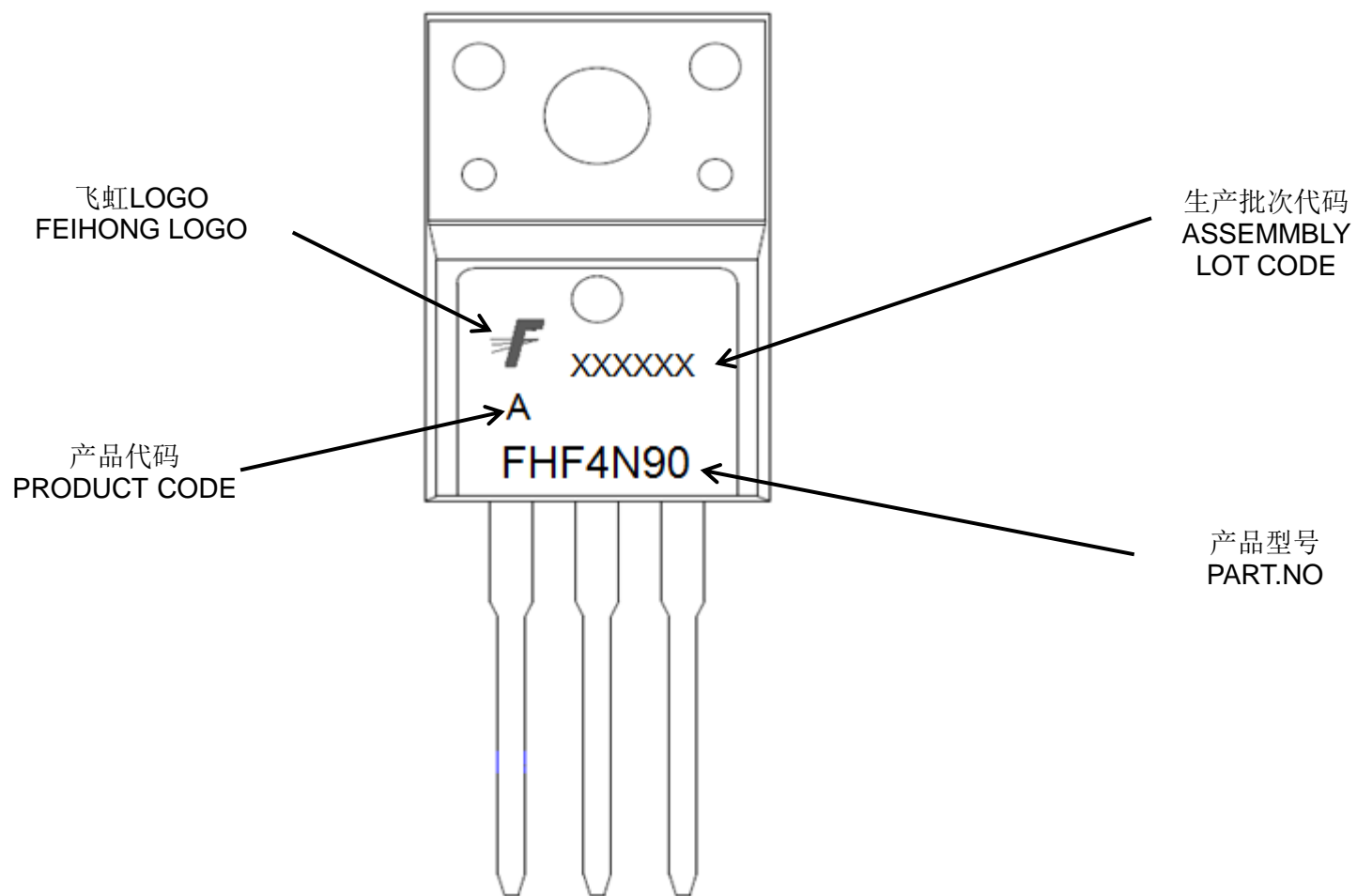

Figure21.Unclamped Inductive Switching Waveform

印记 Marking:



外形尺寸:

Package Dimension:

TO-220F

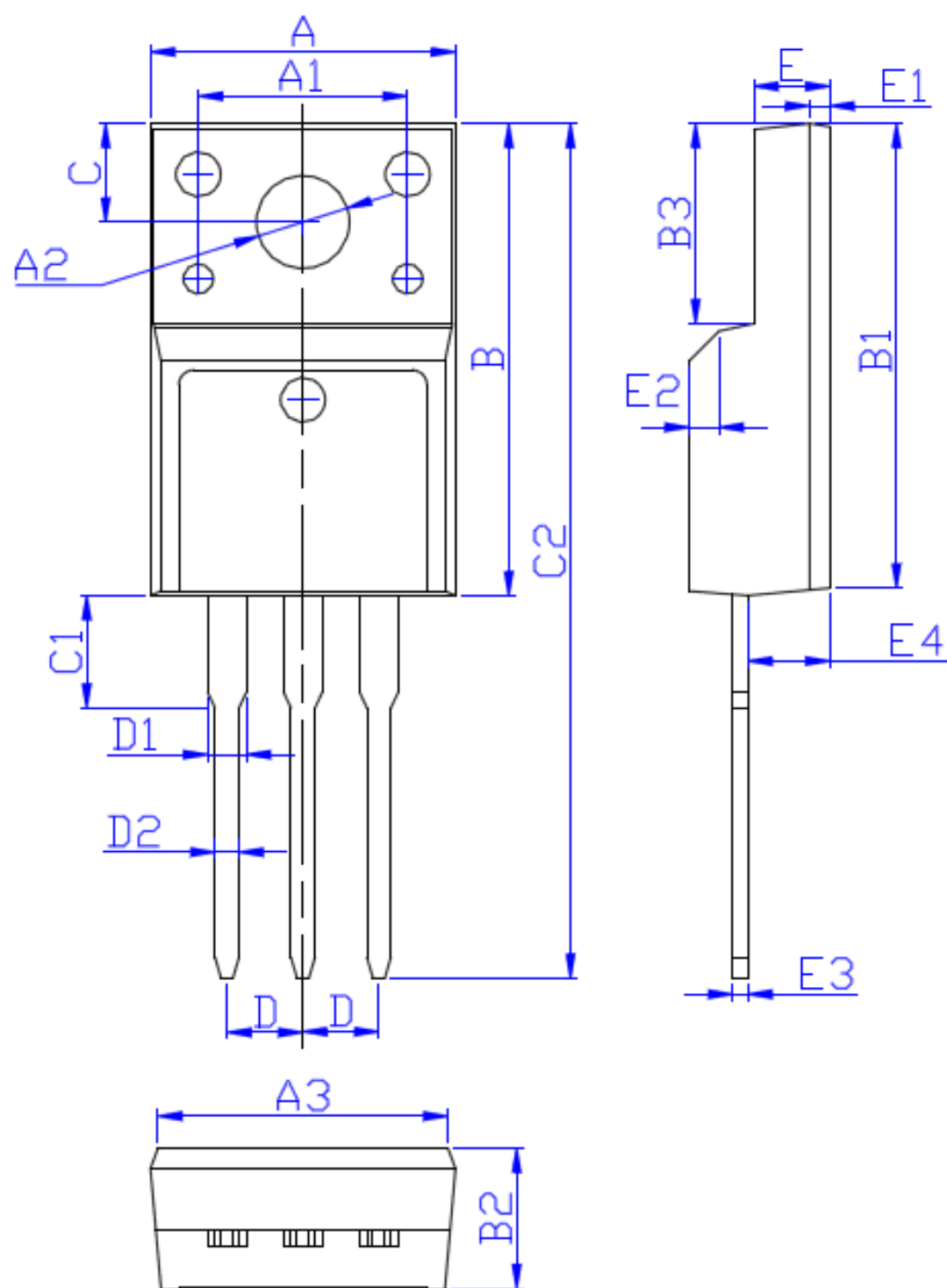

| DIM | MILLIMETERS |
|-----|--------------|
| A | 10.16±0.30 |
| A1 | 7.00±0.20 |
| A2 | 3.12±0.20 |
| A3 | 9.70±0.30 |
| B | 15.90±0.50 |
| B1 | 15.60±0.50 |
| B2 | 4.70±0.30 |
| B3 | 6.70±0.30 |
| C | 3.30±0.25 |
| C1 | 3.25±0.30 |
| C2 | 28.70±0.50 |
| D | Typical 2.54 |
| D1 | 1.47 (MAX) |
| D2 | 0.80±0.20 |
| E | 2.55±0.25 |
| E1 | 0.70±0.25 |
| E2 | 1.0×45° |
| E3 | 0.50±0.20 |
| E4 | 2.75±0.30 |

(Unit:mm)

X-ON Electronics

Largest Supplier of Electrical and Electronic Components

Click to view similar products for [MOSFET](#) category:

Click to view products by [FeiHong](#) manufacturer:

Other Similar products are found below :

[614233C](#) [648584F](#) [MCH3443-TL-E](#) [MCH6422-TL-E](#) [FDPF9N50NZ](#) [FW216A-TL-2W](#) [FW231A-TL-E](#) [APT5010JVR](#) [NTNS3A92PZT5G](#)
[IRF100S201](#) [JANTX2N5237](#) [2SK2464-TL-E](#) [2SK3818-DL-E](#) [FCA20N60_F109](#) [FDZ595PZ](#) [STD6600NT4G](#) [FSS804-TL-E](#) [2SJ277-DL-E](#)
[2SK1691-DL-E](#) [2SK2545\(Q,T\)](#) [D2294UK](#) [405094E](#) [423220D](#) [MCH6646-TL-E](#) [TPCC8103,L1Q\(CM](#) [367-8430-0972-503](#) [VN1206L](#)
[424134F](#) [026935X](#) [051075F](#) [SBVS138LT1G](#) [614234A](#) [715780A](#) [NTNS3166NZT5G](#) [751625C](#) [873612G](#) [IRF7380TRHR](#)
[IPS70R2K0CEAKMA1](#) [RJK60S3DPP-E0#T2](#) [RJK60S5DPK-M0#T0](#) [APT5010JVFR](#) [APT12031JFLL](#) [APT12040JVR](#) [DMN3404LQ-7](#)
[NTE6400](#) [JANTX2N6796U](#) [JANTX2N6784U](#) [JANTXV2N5416U4](#) [SQM110N05-06L-GE3](#) [SIHF35N60E-GE3](#)