



承 认 书

APPROVAL SHEET

客户名称 : _____

产品名称: 车载多层片式陶瓷电容器

尺 寸: AM01~AM20

版 本: _____

日 期: _____

制 造 MANUFACTURER			客 户 CUSTOMER		
拟制 DESIGN	审核 CHECK	批准 APPROVAL	检验 INSPECTOR	审核 CHECK	批准 APPROVAL



一、概述

● 产品概述

- 1、此类电容器为汽车专用电子元器件，已通过 AEC-Q200 标准设定的所有实验条件，在汽车使用过程中更具稳定性、安全性。
- 2、材料使用主要有温度稳定性能较高的 C0G 以及高介电常数的 X7R、X5R、X7S、X7T。
- 3、适用于引擎 ECU 等的驱动系统控制、安全气囊、ABS 等的安全控制装置。

二、型号规格表示方法

 A M 05 CG 101 J 500 N T
 ① ② ③ ④ ⑤ ⑥ ⑦ ⑧ ⑨

※说明：

①A：汽车电子产品

②M：汽车产品系列，应用分类代码

代号	应用描述
U	满足 AEC-Q200，用于车内信息、多媒体、导航、装饰等通用的舒适娱乐模块； 禁用于涉及安全模块的应用，如 ABS、电池、动力传输等
M	满足 AEC-Q200，适用于引擎 ECU 等的驱动系统控制、安全气囊、ABS 等的安全控制装置；
E	满足 AEC-Q200，采用树脂端头工艺，更有效有效抑制板间弯曲产生的应力裂纹，适用于车载电源控制、电池线等易弯曲模块、动力传输模块。
P	满足 AEC-Q200，开路模式产品设计，可以避免开裂导致的瞬间短路烧毁。适用于汽车电池线、动力传输模块。
S	满足符合 IEC60384-14/AEC-Q200 标准，适用于电池充电器、变频器、DC-DC 转换器等



③尺寸

单位: inch/ mm

尺寸规格	01	02	03	05	06	10
长×宽 inch	0.02×0.01	0.04×0.02	0.06×0.03	0.08×0.05	0.12×0.06	0.12×0.10
长×宽 mm	0.60×0.30	1.00×0.50	1.60×0.80	2.00×1.25	3.20×1.60	3.20×2.50

④ 介质种类

介质种类	CG	B	BS	BT	X
介质材料	COG	X7R	X7S	X7T	X5R

⑤ 标称容量

单位(unit): Pf

表示方式	实际值	注: 头两位数字为有效数字, 第三位数字为 0 的个数; R 为小数点。
0R5	0.5	
1R0	1.0	
102	10×10^2	
224	22×10^4	
...	...	

⑥ 容量误差

代码	A	B	C	D	F	G	J	K	M
误差	± 0.05pF	± 0.10pF	± 0.25pF	± 0.5pF	± 1.0%	± 2.0%	± 5.0%	±10%	±20%

备注: A、B、C、D 级误差适用于容量 ≤ 10pF 的产品。

⑦ 额定电压

单位: V

表示方式	实际值	注: 头两位数字为有效数字, 第三位数字为 0 的个数; R 为小数点。
6R3	6.3	
500	50×10^0	
201	20×10^1	
102	10×10^2	
...	...	



⑧ 端头材料

代码	端头类型
N	Cu/Ni/Sn 三层端头
A	柔性端头

备注：具体规格端头类型见容量详情列表

⑨ 包装方式

B	T
散包装	编带包装

三、温度系数/特性

介质种类	参考温度点	标称温度系数	工作温度范围
C0G	20°C	0±30 ppm/°C	-55°C~125°C
X5R	20°C	±15%	-55°C~85°C
X7R	20°C	±15%	-55°C~125°C
X7S	20°C	±22%	-55°C~125°C
X7T	20°C	-33%~22%	-55°C~125°C

备注：I类电容器标称温度系数和允许偏差是采用温度在20°C和85°C之间的电容量变化来确定的，而II类电容器标称温度系数是按照工作范围之间的电容量相对20°C的电容量变化来确定的。

四、尺寸及结构

※ 结构

项目	Cu/Ni/Sn 三层端头产品结构	柔性端头产品结构
结构示意图		
代码描述	① 陶瓷介质 ② 镍电极 ③ 铜电极层 ④ 镍镀层 ⑤ 锡镀层	① 陶瓷介质 ② 镍电极 ③ 铜电极层 ④ 导电性树脂 ⑤ 镍镀层 ⑥ 锡镀层



※ 尺寸

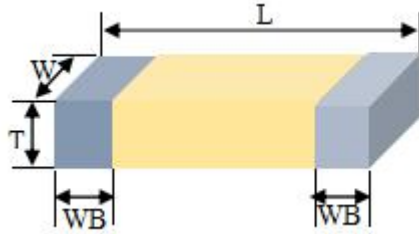

型号	英制表示	公制表示	尺寸 (mm)				备注
			L	W	T	WB	
01	0201	0603	0.6 ± 0.05	0.3 ± 0.05	0.3 ± 0.05	0.15 ± 0.05	
02	0402	1005	1.00 ± 0.05	0.50 ± 0.05	0.50 ± 0.05	0.25 ± 0.05	$C < 1\mu\text{F}$
			1.00 ± 0.15	0.50 ± 0.15	0.50 ± 0.15	0.25 ± 0.05	$1\mu\text{F} \leq C < 10\mu\text{F}$
03	0603	1608	1.60 ± 0.10	0.80 ± 0.10	0.80 ± 0.10	0.35 ± 0.20	$C \leq 1\mu\text{F}$
			1.60 ± 0.20	0.80 ± 0.20	0.80 ± 0.20	0.35 ± 0.20	$C > 1\mu\text{F}$
05	0805	2012	2.00 ± 0.20	1.25 ± 0.20	0.80 ± 0.20	0.50 ± 0.20	$C \leq 0.47 \mu\text{F}$
					1.25 ± 0.20	0.50 ± 0.20	$C > 0.47 \mu\text{F}$
06	1206	3216	3.20 ± 0.30	1.60 ± 0.30	0.80 ± 0.20	0.60 ± 0.30	---
					1.25 ± 0.20		
					1.60 ± 0.30		
10	1210	3225	3.20 ± 0.30	2.50 ± 0.30	≤ 2.80	0.60 ± 0.30	---
08	1808	4520	4.50 ± 0.40	2.00 ± 0.20	≤ 2.20	0.60 ± 0.30	---
12	1812	4532	4.50 ± 0.40	3.20 ± 0.30	≤ 3.50	0.60 ± 0.30	---
20	2220	5750	5.70 ± 0.40	5.00 ± 0.40	≤ 3.50	0.60 ± 0.30	---

备注：1、具体规格通用厚度见容量详情列表。
2、可根据客户的特殊要求设计符合客户需求的产品。



五、容量范围及其电压

I类电容器具体电压对应容量及厚度情况列表

材料	厚度(MM)/端头								
	COG								
	01 (0.6mm*0.3mm)	02 (1.0mm*0.5mm)		03 (1.6mm*0.8mm)		05 (2.0mm*1.25mm)			
电压	50	50	100	50	100	50	100	250	630
0.1 pF	0.3/N	0.5/N	0.5/N						
0.2 pF	0.3/N	0.5/N	0.5/N						
0.5 pF	0.3/N	0.5/N	0.5/N	0.8/N	0.8/N	0.8/N	0.8/N	0.8/N	0.8/N
1 pF	0.3/N	0.5/N	0.5/N	0.8/N	0.8/N	0.8/N	0.8/N	0.8/N	0.8/N
1.2 pF	0.3/N	0.5/N	0.5/N	0.8/N	0.8/N	0.8/N	0.8/N	0.8/N	0.8/N
1.5 pF	0.3/N	0.5/N	0.5/N	0.8/N	0.8/N	0.8/N	0.8/N	0.8/N	0.8/N
1.8 pF	0.3/N	0.5/N	0.5/N	0.8/N	0.8/N	0.8/N	0.8/N	0.8/N	0.8/N
2.0 pF	0.3/N	0.5/N	0.5/N	0.8/N	0.8/N	0.8/N	0.8/N	0.8/N	0.8/N
2.2 pF	0.3/N	0.5/N	0.5/N	0.8/N	0.8/N	0.8/N	0.8/N	0.8/N	0.8/N
2.7 pF	0.3/N	0.5/N	0.5/N	0.8/N	0.8/N	0.8/N	0.8/N	0.8/N	0.8/N
3.0 pF	0.3/N	0.5/N	0.5/N	0.8/N	0.8/N	0.8/N	0.8/N	0.8/N	0.8/N
3.3 pF	0.3/N	0.5/N	0.5/N	0.8/N	0.8/N	0.8/N	0.8/N	0.8/N	0.8/N
3.6 pF	0.3/N	0.5/N	0.5/N	0.8/N	0.8/N	0.8/N	0.8/N	0.8/N	0.8/N
3.9 pF	0.3/N	0.5/N	0.5/N	0.8/N	0.8/N	0.8/N	0.8/N	0.8/N	0.8/N
4.7 pF	0.3/N	0.5/N	0.5/N	0.8/N	0.8/N	0.8/N	0.8/N	0.8/N	0.8/N
5.0 pF	0.3/N	0.5/N	0.5/N	0.8/N	0.8/N	0.8/N	0.8/N	0.8/N	0.8/N
5.6 pF	0.3/N	0.5/N	0.5/N	0.8/N	0.8/N	0.8/N	0.8/N	0.8/N	0.8/N
6.8 pF	0.3/N	0.5/N	0.5/N	0.8/N	0.8/N	0.8/N	0.8/N	0.8/N	0.8/N
8.0 pF	0.3/N	0.5/N	0.5/N	0.8/N	0.8/N	0.8/N	0.8/N	0.8/N	0.8/N
8.2 pF	0.3/N	0.5/N	0.5/N	0.8/N	0.8/N	0.8/N	0.8/N	0.8/N	0.8/N
10 pF	0.3/N	0.5/N	0.5/N	0.8/N	0.8/N	0.8/N	0.8/N	0.8/N	0.8/N
12 pF	0.3/N	0.5/N	0.5/N	0.8/N	0.8/N	0.8/N	0.8/N	0.8/N	0.8/N
15 pF	0.3/N	0.5/N	0.5/N	0.8/N	0.8/N	0.8/N	0.8/N	0.8/N	0.8/N
18 pF	0.3/N	0.5/N	0.5/N	0.8/N	0.8/N	0.8/N	0.8/N	0.8/N	0.8/N
22 pF	0.3/N	0.5/N	0.5/N	0.8/N	0.8/N	0.8/N	0.8/N	0.8/N	0.8/N
27 pF	0.3/N	0.5/N	0.5/N	0.8/N	0.8/N	0.8/N	0.8/N	0.8/N	0.8/N
33 pF	0.3/N	0.5/N	0.5/N	0.8/N	0.8/N	0.8/N	0.8/N	0.8/N	0.8/N
39 pF	0.3/N	0.5/N	0.5/N	0.8/N	0.8/N	0.8/N	0.8/N	0.8/N	0.8/N
47 pF	0.3/N	0.5/N	0.5/N	0.8/N	0.8/N	0.8/N	0.8/N	0.8/N	0.8/N
56 pF	0.3/N	0.5/N	0.5/N	0.8/N	0.8/N	0.8/N	0.8/N	0.8/N	0.8/N
68 pF	0.3/N	0.5/N	0.5/N	0.8/N	0.8/N	0.8/N	0.8/N	0.8/N	0.8/N
100 pF	0.3/N	0.5/N	0.5/N	0.8/N	0.8/N	0.8/N	0.8/N	0.8/N	0.8/N
120 pF		0.5/N		0.8/N	0.8/N	0.8/N	0.8/N	0.8/N	0.8/N
150 pF		0.5/N		0.8/N	0.8/N	0.8/N	0.8/N	0.8/N	1.25/N
180 pF		0.5/N		0.8/N	0.8/N	0.8/N	0.8/N	0.8/N	1.25/N
220 pF		0.5/N		0.8/N	0.8/N	0.8/N	0.8/N	0.8/N	1.25/N
270 pF		0.5/N		0.8/N	0.8/N	0.8/N	0.8/N	0.8/N	1.25/N
330 pF		0.5/N		0.8/N	0.8/N	0.8/N	0.8/N	0.8/N	1.25/N
390 pF		0.5/N		0.8/N	0.8/N	0.8/N	0.8/N	0.8/N	
470 pF		0.5/N		0.8/N	0.8/N	0.8/N	0.8/N	0.8/N	
560 pF		0.5/N		0.8/N	0.8/N	0.8/N	0.8/N	0.8/N	
680 pF		0.5/N		0.8/N	0.8/N	0.8/N	0.8/N	0.8/N	
1 nF		0.5/N		0.8/N	0.8/N	0.8/N	0.8/N	0.8/N	
1.5 nF				0.8/N		0.8/N			
1.8 nF				0.8/N		0.8/N			
2.2 nF				0.8/N		0.8/N			
2.7 nF						0.8/N			
3.3 nF						0.8/N			
3.9 nF									

备注：1、N：Cu/Ni/Sn 三层端头 A：柔性端头

2、可根据客户的特殊要求设计符合客户需求的产品



I类电容器具体电压对应容量及厚度情况列表

厚度(MM)/端头

材料	COG								
	尺寸	06 (3.2mm*1.6mm)				10 (3.2mm*2.5mm)			
		电压	50	100	250	630	1000	250	630
0.1 pF									
0.2 pF									
0.5 pF		0.8/N	0.8/N	0.8/N	1.25/N	1.25/N			
1 pF		0.8/N	0.8/N	0.8/N	1.25/N	1.25/N	1.25/N	1.25/N	1.25/N
1.2 pF		0.8/N	0.8/N	0.8/N	1.25/N	1.25/N	1.25/N	1.25/N	1.25/N
1.5 pF		0.8/N	0.8/N	0.8/N	1.25/N	1.25/N	1.25/N	1.25/N	1.25/N
1.8 pF		0.8/N	0.8/N	0.8/N	1.25/N	1.25/N	1.25/N	1.25/N	1.25/N
2.0 pF		0.8/N	0.8/N	0.8/N	1.25/N	1.25/N	1.25/N	1.25/N	1.25/N
2.2 pF		0.8/N	0.8/N	0.8/N	1.25/N	1.25/N	1.25/N	1.25/N	1.25/N
2.7 pF		0.8/N	0.8/N	0.8/N	1.25/N	1.25/N	1.25/N	1.25/N	1.25/N
3.0 pF		0.8/N	0.8/N	0.8/N	1.25/N	1.25/N	1.25/N	1.25/N	1.25/N
3.3 pF		0.8/N	0.8/N	0.8/N	1.25/N	1.25/N	1.25/N	1.25/N	1.25/N
3.6 pF		0.8/N	0.8/N	0.8/N	1.25/N	1.25/N	1.25/N	1.25/N	1.25/N
3.9 pF		0.8/N	0.8/N	0.8/N	1.25/N	1.25/N	1.25/N	1.25/N	1.25/N
4.7 pF		0.8/N	0.8/N	0.8/N	1.25/N	1.25/N	1.25/N	1.25/N	1.25/N
5.0 pF		0.8/N	0.8/N	0.8/N	1.25/N	1.25/N	1.25/N	1.25/N	1.25/N
5.6 pF		0.8/N	0.8/N	0.8/N	1.25/N	1.25/N	1.25/N	1.25/N	1.25/N
6.8 pF		0.8/N	0.8/N	0.8/N	1.25/N	1.25/N	1.25/N	1.25/N	1.25/N
8.0 pF		0.8/N	0.8/N	0.8/N	1.25/N	1.25/N	1.25/N	1.25/N	1.25/N
8.2 pF		0.8/N	0.8/N	0.8/N	1.25/N	1.25/N	1.25/N	1.25/N	1.25/N
10 pF		0.8/N	0.8/N	0.8/N	1.25/N	1.25/N	1.25/N	1.25/N	1.25/N
12 pF		0.8/N	0.8/N	0.8/N	1.25/N	1.25/N	1.25/N	1.25/N	1.25/N
15 pF		0.8/N	0.8/N	0.8/N	1.25/N	1.25/N	1.25/N	1.25/N	1.25/N
18 pF		0.8/N	0.8/N	0.8/N	1.25/N	1.25/N	1.25/N	1.25/N	1.25/N
22 pF		0.8/N	0.8/N	0.8/N	1.25/N	1.25/N	1.25/N	1.25/N	1.25/N
27 pF		0.8/N	0.8/N	0.8/N	1.25/N	1.25/N	1.25/N	1.25/N	1.25/N
33 pF		0.8/N	0.8/N	0.8/N	1.25/N	1.25/N	1.25/N	1.25/N	1.25/N
39 pF		0.8/N	0.8/N	0.8/N	1.25/N	1.25/N	1.25/N	1.25/N	1.25/N
47 pF		0.8/N	0.8/N	0.8/N	1.25/N	1.25/N	1.25/N	1.25/N	1.25/N
56 pF		0.8/N	0.8/N	0.8/N	1.25/N	1.25/N	1.25/N	1.25/N	1.25/N
68 pF		0.8/N	0.8/N	0.8/N	1.25/N	1.25/N	1.25/N	1.25/N	1.25/N
100 pF		0.8/N	0.8/N	0.8/N	1.25/N	1.25/N	1.25/N	1.25/N	1.25/N
120 pF		0.8/N	0.8/N	0.8/N	1.25/N	1.25/N	1.25/N	1.25/N	1.25/N
150 pF		0.8/N	0.8/N	0.8/N	1.25/N	1.25/N	1.25/N	1.25/N	1.25/N
180 pF		0.8/N	0.8/N	0.8/N	1.25/N	1.25/N	1.25/N	1.25/N	1.25/N
220 pF		0.8/N	0.8/N	0.8/N	1.25/N	1.25/N	1.25/N	1.25/N	1.6/N
270 pF		0.8/N	0.8/N	0.8/N	1.25/N	1.25/N	1.25/N	1.25/N	1.6/N
330 pF		0.8/N	0.8/N	0.8/N	1.25/N	1.25/N	1.25/N	1.25/N	1.6/N
390 pF		0.8/N	0.8/N	0.8/N	1.25/N	1.25/N	1.25/N	1.25/N	
470 pF		0.8/N	0.8/N	0.8/N	1.25/N	1.25/N	1.25/N	1.25/N	
560 pF		0.8/N	0.8/N	0.8/N	1.25/N	1.6/N	1.25/N	1.25/N	
680 pF		0.8/N	0.8/N	0.8/N	1.25/N	1.6/N	1.25/N	1.25/N	
1 nF		0.8/N	0.8/N	0.8/N	1.6/N		1.25/N	1.6/N	
1.5 nF		1.25/N	1.25/N	1.25/N			1.25/N	1.7/N	
1.8 nF		1.25/N	1.25/N	1.25/N			1.25/N	2.0/N	
2.2 nF		1.25/N	1.25/N	1.25/N			1.6/N		
2.7 nF							1.6/N		
3.3 nF							1.6/N		
3.9 nF									

备注：1、N：Cu/Ni/Sn 三层端头 A：柔性端头

2、可根据客户的特殊要求设计符合客户需求的产品



I类电容器具体电压对应容量及厚度情况列表

厚度(MM)/端头

材料	COG								
	08 (4.5mm*2.0mm)			12 (4.5mm*3.2mm)			20 (5.7mm*5.0mm)		
尺寸	250	630	1000	250	630	1000	250	630	1000
电压	250	630	1000	250	630	1000	250	630	1000
1 pF	1.6/N	1.6/N	1.6/N	1.6/N	1.6/N	1.6/N	1.6/N	1.6/N	1.6/N
1.5 pF	1.6/N	1.6/N	1.6/N	1.6/N	1.6/N	1.6/N	1.6/N	1.6/N	1.6/N
1.8 pF	1.6/N	1.6/N	1.6/N	1.6/N	1.6/N	1.6/N	1.6/N	1.6/N	1.6/N
2.0 pF	1.6/N	1.6/N	1.6/N	1.6/N	1.6/N	1.6/N	1.6/N	1.6/N	1.6/N
2.2 pF	1.6/N	1.6/N	1.6/N	1.6/N	1.6/N	1.6/N	1.6/N	1.6/N	1.6/N
2.7 pF	1.6/N	1.6/N	1.6/N	1.6/N	1.6/N	1.6/N	1.6/N	1.6/N	1.6/N
3.0 pF	1.6/N	1.6/N	1.6/N	1.6/N	1.6/N	1.6/N	1.6/N	1.6/N	1.6/N
3.3 pF	1.6/N	1.6/N	1.6/N	1.6/N	1.6/N	1.6/N	1.6/N	1.6/N	1.6/N
3.6 pF	1.6/N	1.6/N	1.6/N	1.6/N	1.6/N	1.6/N	1.6/N	1.6/N	1.6/N
3.9 pF	1.6/N	1.6/N	1.6/N	1.6/N	1.6/N	1.6/N	1.6/N	1.6/N	1.6/N
4.7 pF	1.6/N	1.6/N	1.6/N	1.6/N	1.6/N	1.6/N	1.6/N	1.6/N	1.6/N
5.0 pF	1.6/N	1.6/N	1.6/N	1.6/N	1.6/N	1.6/N	1.6/N	1.6/N	1.6/N
5.6 pF	1.6/N	1.6/N	1.6/N	1.6/N	1.6/N	1.6/N	1.6/N	1.6/N	1.6/N
6.8 pF	1.6/N	1.6/N	1.6/N	1.6/N	1.6/N	1.6/N	1.6/N	1.6/N	1.6/N
8.0 pF	1.6/N	1.6/N	1.6/N	1.6/N	1.6/N	1.6/N	1.6/N	1.6/N	1.6/N
8.2 pF	1.6/N	1.6/N	1.6/N	1.6/N	1.6/N	1.6/N	1.6/N	1.6/N	1.6/N
10 pF	1.6/N	1.6/N	1.6/N	1.6/N	1.6/N	1.6/N	1.6/N	1.6/N	1.6/N
12 pF	1.6/N	1.6/N	1.6/N	1.6/N	1.6/N	1.6/N	1.6/N	1.6/N	1.6/N
15 pF	1.6/N	1.6/N	1.6/N	1.6/N	1.6/N	1.6/N	1.6/N	1.6/N	1.6/N
18 pF	1.6/N	1.6/N	1.6/N	1.6/N	1.6/N	1.6/N	1.6/N	1.6/N	1.6/N
22 pF	1.6/N	1.6/N	1.6/N	1.6/N	1.6/N	1.6/N	1.6/N	1.6/N	1.6/N
27 pF	1.6/N	1.6/N	1.6/N	1.6/N	1.6/N	1.6/N	1.6/N	1.6/N	1.6/N
33 pF	1.6/N	1.6/N	1.6/N	1.6/N	1.6/N	1.6/N	1.6/N	1.6/N	1.6/N
39 pF	1.6/N	1.6/N	1.6/N	1.6/N	1.6/N	1.6/N	1.6/N	1.6/N	1.6/N
47 pF	1.6/N	1.6/N	1.6/N	1.6/N	1.6/N	1.6/N	1.6/N	1.6/N	1.6/N
56 pF	1.6/N	1.6/N	1.6/N	1.6/N	1.6/N	1.6/N	1.6/N	1.6/N	1.6/N
68 pF	1.6/N	1.6/N	1.6/N	1.6/N	1.6/N	1.6/N	1.6/N	1.6/N	1.6/N
100 pF	1.6/N	1.6/N	1.6/N	1.6/N	1.6/N	1.6/N	1.6/N	1.6/N	1.6/N
120 pF	1.6/N	1.6/N	1.6/N	1.6/N	1.6/N	1.6/N	1.6/N	1.6/N	1.6/N
150 pF	1.6/N	1.6/N	1.6/N	1.6/N	1.6/N	1.6/N	1.6/N	1.6/N	1.6/N
180 pF	1.6/N	1.6/N	1.6/N	1.6/N	1.6/N	1.6/N	1.6/N	1.6/N	1.6/N
220 pF	1.6/N	1.6/N	1.6/N	1.6/N	1.6/N	1.6/N	1.6/N	1.6/N	1.6/N
270 pF	1.6/N	1.6/N	1.6/N	1.6/N	1.6/N	1.6/N	1.6/N	1.6/N	1.6/N
330 pF	1.6/N	1.6/N	1.6/N	1.6/N	1.6/N	1.6/N	1.6/N	1.6/N	1.6/N
390 pF	1.6/N	1.6/N	1.6/N	1.6/N	1.6/N	1.6/N	1.6/N	1.6/N	1.6/N
470 pF	1.6/N	1.6/N	1.6/N	1.6/N	1.6/N	1.6/N	1.6/N	1.6/N	1.6/N
560 pF	1.6/N	1.6/N	1.6/N	1.6/N	1.6/N	1.6/N	1.6/N	1.6/N	1.6/N
680 pF	1.6/N	1.6/N	1.6/N	1.6/N	1.6/N	1.6/N	1.6/N	1.6/N	1.6/N
1 nF	1.6/N	1.6/N		1.6/N	1.6/N	2.0/N	1.6/N	1.6/N	1.6/N
1.5 nF	1.6/N	1.6/N		1.6/N	1.6/N		1.6/N	1.6/N	2.0/N
1.8 nF	1.6/N			1.6/N	1.6/N		1.6/N	1.6/N	2.0/N
2.2 nF	1.6/N			1.6/N	1.6/N		1.6/N	1.6/N	
2.7 nF	1.6/N			1.6/N	2.0/N		1.6/N	1.6/N	
3.3 nF	1.6/N			1.6/N	2.0/N		1.6/N	1.6/N	
3.9 nF	1.6/N			1.6/N	2.0/N		1.6/N	1.6/N	
4.7 nF				1.6/N	2.0/N		1.6/N	1.6/N	
5.6 nF				1.6/N			1.6/N	1.6/N	
6.8 nF				1.6/N			1.6/N	1.6/N	
10 nF							1.6/N		
15 nF							1.6/N		

备注：1、N：Cu/Ni/Sn 三层端头 A：柔性端头

2、可根据客户的特殊要求设计符合客户需求的产品



II 类电容器具体电压对应容量及厚度情况列表

AM01 0.6mm*0.3mm

厚度(MM)/端头

材料 电压	E7R				E7S			E7T	
	10	16	25	50	6.3	10	16	6.3	10
100pF									
120pF				0.3/N					
150pF				0.3/N					
180pF				0.3/N					
220pF				0.3/N					
270pF				0.3/N					
330pF				0.3/N					
390pF				0.3/N					
470pF				0.3/N					
560pF				0.3/N					
680pF				0.3/N					
1nF				0.3/N					
1.2nF				0.3/N					
1.5nF				0.3/N					
1.8nF				0.3/N					
2.2nF				0.3/N					
2.7nF				0.3/N					
3.3nF				0.3/N					
3.9nF				0.3/N					
4.7nF				0.3/N					
5.6nF	0.3/N	0.3/N	0.3/N						
6.8nF	0.3/N	0.3/N	0.3/N						
10nF	0.3/N	0.3/N	0.3/N						
12nF							0.3/N		
15nF							0.3/N		
18nF							0.3/N		
22nF							0.3/N		
27nF							0.3/N		
33nF					0.3/N	0.3/N	0.3/N		
39nF					0.3/N	0.3/N			
47nF					0.3/N	0.3/N			
56nF								0.3/N	0.3/N
68nF								0.3/N	0.3/N
100nF								0.3/N	0.3/N
220nF									
330nF									
470nF									
680nF									
1uF									
2.2uF									
3.3uF									
4.7uF									

备注：1、N：Cu/Ni/Sn 三层端头 A：柔性端头

2、可根据客户的特殊要求设计符合客户需求的产品



II 类电容器具体电压对应容量及厚度情况列表 0402

AM02 1.0mm*0.5mm

厚度(MM)/端头

材料 电压	K7R					K5R				K7S			K7T		
	6.3	10	16	25	50	100	6.3	10	16	25	6.3	10	16	6.3	10
100pF					0.5/A	0.5/A									
120pF					0.5/A	0.5/A									
150pF					0.5/A	0.5/A									
180pF					0.5/A	0.5/A									
220pF					0.5/A	0.5/A									
270pF					0.5/A	0.5/A									
330pF					0.5/A	0.5/A									
390pF					0.5/A	0.5/A									
470pF					0.5/A	0.5/A									
560pF					0.5/A	0.5/A									
680pF					0.5/A	0.5/A									
1nF					0.5/A	0.5/A									
1.2nF					0.5/A	0.5/A									
1.5nF					0.5/A	0.5/A									
1.8nF					0.5/A	0.5/A									
2.2nF					0.5/A	0.5/A									
2.7nF					0.5/A	0.5/A									
3.3nF					0.5/A	0.5/A									
3.9nF					0.5/A	0.5/A									
4.7nF					0.5/A	0.5/A									
5.6nF					0.5/A	0.5/A									
6.8nF					0.5/A	0.5/A									
10nF					0.5/A										
12nF				0.5/A	0.5/A										
15nF				0.5/A	0.5/A										
18nF				0.5/A	0.5/A										
22nF				0.5/A	0.5/A										
27nF				0.5/A	0.5/A										
33nF	0.5/A	0.5/A	0.5/A	0.5/A	0.5/A										
39nF	0.5/A	0.5/A	0.5/A	0.5/A	0.5/A										
47nF	0.5/A	0.5/A	0.5/A	0.5/A	0.5/A										
56nF	0.5/A	0.5/A	0.5/A	0.5/A	0.5/A										
68nF	0.5/A	0.5/A	0.5/A	0.5/A	0.5/A										
100nF	0.5/A	0.5/A	0.5/A	0.5/A	0.5/A										
220nF							0.5/N	0.5/N	0.5/N	0.5/N	0.5/N	0.5/N	0.5/N		
330nF							0.5/N	0.5/N	0.5/N					0.5/N	0.5/N
470nF							0.5/N	0.5/N	0.5/N					0.5/N	0.5/N
680nF							0.5/N	0.5/N						0.5/N	0.5/N
1uF							0.5/N	0.5/N						0.5/N	0.5/N
2.2uF							0.5/N								
3.3uF															
4.7uF															

备注：1、N：Cu/Ni/Sn 三层端头 A：柔性端头

2、可根据客户的特殊要求设计符合客户需求的产品



II 类电容器具体电压对应容量及厚度情况列表

AM03 1.6mm*0.8mm

厚度(MM)/端头

材料 电压	K7R						K5R				
	6.3	10	16	25	50	100	6.3	10	16	25	50
100pF					0.8/A	0.8/A					
120pF					0.8/A	0.8/A					
150pF					0.8/A	0.8/A					
180pF					0.8/A	0.8/A					
220pF					0.8/A	0.8/A					
270pF					0.8/A	0.8/A					
330pF					0.8/A	0.8/A					
390pF					0.8/A	0.8/A					
470pF					0.8/A	0.8/A					
560pF					0.8/A	0.8/A					
680pF					0.8/A	0.8/A					
1nF					0.8/A	0.8/A					
1.2nF					0.8/A	0.8/A					
1.5nF					0.8/A	0.8/A					
1.8nF					0.8/A	0.8/A					
2.2nF					0.8/A	0.8/A					
2.7nF					0.8/A	0.8/A					
3.3nF					0.8/A	0.8/A					
3.9nF					0.8/A	0.8/A					
4.7nF					0.8/A	0.8/A					
5.6nF					0.8/A	0.8/A					
6.8nF					0.8/A	0.8/A					
10nF					0.8/A	0.8/A					
12nF					0.8/A	0.8/A					
15nF					0.8/A	0.8/A					
18nF					0.8/A	0.8/A					
22nF					0.8/A	0.8/A					
27nF					0.8/A	0.8/A					
33nF					0.8/A	0.8/A					
39nF					0.8/A	0.8/A					
47nF	0.8/A	0.8/A	0.8/A	0.8/A	0.8/A	0.8/A					
56nF	0.8/A	0.8/A	0.8/A	0.8/A	0.8/A	0.8/A					
68nF	0.8/A	0.8/A	0.8/A	0.8/A	0.8/A	0.8/A					
100nF	0.8/A	0.8/A	0.8/A	0.8/A	0.8/A	0.8/A					
220nF	0.8/N	0.8/N	0.8/N	0.8/N							0.8/N
330nF								0.8/N	0.8/N	0.8/N	0.8/N
470nF							0.8/N	0.8/N	0.8/N	0.8/N	0.8/N
680nF							0.8/N	0.8/N	0.8/N	0.8/N	0.8/N
1uF							0.8/N	0.8/N	0.8/N	0.8/N	0.8/N
2.2uF							0.8/N	0.8/N	0.8/N		
3.3uF							0.8/N				
4.7uF							0.8/N				
6.8uF							0.8/N				
10uF							0.8/N				

AM03 1.6mm*0.8mm

厚度(MM)/端头

材料 电压	K7S					K7T	
	6.3	10	16	25	50	6.3	10
100nF							
220nF					0.8/N		
330nF	0.8/N	0.8/N	0.8/N	0.8/N			
470nF	0.8/N	0.8/N	0.8/N	0.8/N			
680nF	0.8/N	0.8/N	0.8/N	0.8/N			
1uF	0.8/N	0.8/N	0.8/N	0.8/N			
2.2uF						0.8/N	0.8/N
3.3uF						0.8/N	
4.7uF						0.8/N	
6.8uF						0.8/N	
10uF						0.8/N	

备注:

1、N: Cu/Ni/Sn 三层端头

A: 柔性端头

2、可根据客户的特殊要求设计符合客户需求的产品



II类电容器具体电压对应容量及厚度情况列表

AM05 2.0mm*1.25mm

厚度(MM)/端头

材料 电压	X7R				X5R					
	16	25	50	100	6.3	10	16	25	50	100
100pF			0.8/A	0.8/A						
120pF			0.8/A	0.8/A						
150pF			0.8/A	0.8/A						
180pF			0.8/A	0.8/A						
220pF			0.8/A	0.8/A						
270pF			0.8/A	0.8/A						
330pF			0.8/A	0.8/A						
390pF			0.8/A	0.8/A						
470pF			0.8/A	0.8/A						
560pF			0.8/A	0.8/A						
680pF			0.8/A	0.8/A						
1nF			0.8/A	0.8/A						
1.2nF			0.8/A	0.8/A						
1.5nF			0.8/A	0.8/A						
1.8nF			0.8/A	0.8/A						
2.2nF			0.8/A	0.8/A						
2.7nF			0.8/A	0.8/A						
3.3nF			0.8/A	0.8/A						
3.9nF			0.8/A	0.8/A						
4.7nF			0.8/A	0.8/A						
5.6nF			0.8/A	0.8/A						
6.8nF			0.8/A	0.8/A						
10nF			0.8/A	0.8/A						
12nF			0.8/A	0.8/A						
15nF			0.8/A	0.8/A						
18nF			0.8/A	0.8/A						
22nF			0.8/A	0.8/A						
27nF			0.8/A	0.8/A						
33nF			0.8/A	0.8/A						
39nF			0.8/A	0.8/A						
47nF			0.8/A	0.8/A						
56nF			0.8/A	0.8/A						
68nF			0.8/A	1.25/A						
100nF			0.8/A	1.25/A						
220nF			0.8/N	1.25/N						
330nF			0.8/N	1.25/N						
470nF	1.25/N	1.25/N	1.25/N	1.25/N						
680nF	1.25/N	1.25/N	1.25/N							1.25/N
1uF	1.25/N	1.25/N	1.25/N						1.25/N	1.25/N
2.2uF					1.25/N	1.25/N	1.25/N	1.25/N		
3.3uF					1.25/N	1.25/N	1.25/N	1.25/N		
4.7uF					1.25/N	1.25/N	1.25/N	1.25/N		
6.8uF					1.25/N	1.25/N				
10uF					1.25/N	1.25/N				
22uF					1.25/N					

AM05 2.0mm*1.25mm

厚度(MM)/端头

材料 电压	X7S					X7T				
	6.3	10	16	25	50	6.3	10	16	25	100
470nF										
680nF										1.25/N
1uF	1.25/N	1.25/N	1.25/N	1.25/N	1.25/N					
2.2uF	1.25/N	1.25/N	1.25/N							
3.3uF						1.25/N	1.25/N	1.25/N	1.25/N	
4.7uF						1.25/N	1.25/N	1.25/N	1.25/N	
6.8uF						1.25/N				
10uF						1.25/N				
22uF						1.25/N				

备注：1、N：Cu/Ni/Sn 三层端头 A：柔性端头
2、可根据客户的特殊要求设计符合客户需求的产品



II 类电容器具体电压对应容量及厚度情况列表

AM06 3.2mm*1.6mm

厚度(MM)/端头

材料 电压	X7R					
	6.3	10	16	25	50	100
100 pF						
120 pF						
150 pF					0.8/A	0.8/A
180 pF					0.8/A	0.8/A
220 pF					0.8/A	0.8/A
270 pF					0.8/A	0.8/A
330 pF					0.8/A	0.8/A
390 pF					0.8/A	0.8/A
470 pF					0.8/A	0.8/A
560 pF					0.8/A	0.8/A
680 pF					0.8/A	0.8/A
1 nF					0.8/A	0.8/A
1.2 nF					0.8/A	0.8/A
1.5 nF					0.8/A	0.8/A
1.8 nF					0.8/A	0.8/A
2.2 nF					0.8/A	0.8/A
2.7 nF					0.8/A	0.8/A
3.3 nF					0.8/A	0.8/A
3.9 nF					0.8/A	0.8/A
4.7 nF					0.8/A	0.8/A
5.6 nF					0.8/A	0.8/A
6.8 nF					0.8/A	0.8/A
10 nF					0.8/A	0.8/A
12 nF					0.8/A	0.8/A
15 nF					0.8/A	0.8/A
18 nF					0.8/A	0.8/A
22 nF					0.8/A	0.8/A
27 nF					0.8/A	0.8/A
33 nF					0.8/A	0.8/A
39 nF					0.8/A	0.8/A
47 nF					0.8/A	0.8/A
56 nF					0.8/A	0.8/A
68 nF					0.8/A	0.8/A
100 nF					0.8/A	1.25/A
220 nF					0.8/N	1.25/N
330 nF					0.8/N	1.6/N
470 nF					0.8/N	1.6/N
680 nF					0.8/N	1.6/N
1 uF	0.8/N	0.8/N	0.8/N	0.8/N	1.6/N	1.6/N
2.2 uF	1.6/N	1.6/N	1.6/N	1.6/N	1.6/N	
3.3 uF	1.6/N	1.6/N	1.6/N	1.6/N		
4.7 uF	1.6/N	1.6/N	1.6/N	1.6/N		
6.8 uF						
10 uF						
15 uF						
22 uF						

AM06 3.2mm*1.6mm

厚度(MM)/端头

材料 电压	X5R				X7T			
	6.3	10	16	25	6.3	10	16	25
2.2 uF								
3.3 uF								
4.7 uF								
6.8 uF	1.6/N	1.6/N	1.6/N	1.6/N	1.6/N	1.6/N	1.6/N	1.6/N
10 uF	1.6/N	1.6/N	1.6/N	1.6/N	1.6/N	1.6/N	1.6/N	1.6/N
15 uF	1.6/N	1.6/N	1.6/N	1.6/N	1.6/N	1.6/N	1.6/N	1.6/N
22 uF	1.6/N	1.6/N	1.6/N	1.6/N	1.6/N	1.6/N	1.6/N	1.6/N

备注：1、N：Cu/Ni/Sn 三层端头 A：柔性端头

2、可根据客户的特殊要求设计符合客户需求的产品



II 类电容器具体电压对应容量及厚度情况列表

厚度(MM)/端头

尺寸	10 (3.2mm*2.5mm)			08 (4.5mm*2.0mm)			12 (4.5mm*3.2mm)		
	K7R		K7S	K7R		K7S	K7R		K7S
材料	25	50	100	250	630	1000	250	630	1000
电压	25	50	100	250	630	1000	250	630	1000
100pF			1.25/A	1.6/N	1.6/N	1.6/N	1.6/N	1.6/N	1.6/N
120pF			1.25/A	1.6/N	1.6/N	1.6/N	1.6/N	1.6/N	1.6/N
150pF			1.25/A	1.6/N	1.6/N	1.6/N	1.6/N	1.6/N	1.6/N
180pF			1.25/A	1.6/N	1.6/N	1.6/N	1.6/N	1.6/N	1.6/N
220pF			1.25/A	1.6/N	1.6/N	1.6/N	1.6/N	1.6/N	1.6/N
270pF			1.25/A	1.6/N	1.6/N	1.6/N	1.6/N	1.6/N	1.6/N
330pF			1.25/A	1.6/N	1.6/N	1.6/N	1.6/N	1.6/N	1.6/N
390pF			1.25/A	1.6/N	1.6/N	1.6/N	1.6/N	1.6/N	1.6/N
470pF			1.25/A	1.6/N	1.6/N	1.6/N	1.6/N	1.6/N	1.6/N
560pF			1.25/A	1.6/N	1.6/N	1.6/N	1.6/N	1.6/N	1.6/N
680pF			1.25/A	1.6/N	1.6/N	1.6/N	1.6/N	1.6/N	1.6/N
1nF			1.25/A	1.6/N	1.6/N	1.6/N	1.6/N	1.6/N	1.6/N
1.2nF			1.25/A	1.6/N	1.6/N	1.6/N	1.6/N	1.6/N	1.6/N
1.5nF			1.25/A	1.6/N	1.6/N	1.6/N	1.6/N	1.6/N	1.6/N
1.8nF			1.25/A	1.6/N	1.6/N	1.6/N	1.6/N	1.6/N	1.6/N
2.2nF			1.25/A	1.6/N	1.6/N	1.6/N	1.6/N	1.6/N	1.6/N
2.7nF			1.25/A	1.6/N	1.6/N	1.6/N	1.6/N	1.6/N	1.6/N
3.3nF			1.25/A	1.6/N	1.6/N	1.6/N	1.6/N	1.6/N	1.6/N
3.9nF			1.25/A	1.6/N	1.6/N	1.6/N	1.6/N	1.6/N	1.6/N
4.7nF			1.25/A	1.6/N	1.6/N	1.6/N	1.6/N	1.6/N	1.6/N
5.6nF			1.25/A	1.6/N	1.6/N	1.6/N	1.6/N	1.6/N	1.6/N
6.8nF			1.25/A	1.6/N	1.6/N	1.6/N	1.6/N	1.6/N	1.6/N
10nF			1.25/A	1.6/N	1.6/N	1.6/N	1.6/N	1.6/N	1.6/N
12nF			1.25/A	1.6/N	1.6/N	1.6/N	1.6/N	1.6/N	1.6/N
15nF			1.25/A	1.6/N	1.6/N	1.6/N	1.6/N	1.6/N	1.6/N
18nF			1.25/A				1.6/N	1.6/N	1.6/N
22nF			1.25/A				1.6/N	1.6/N	1.6/N
27nF			1.25/A				1.6/N	1.6/N	1.6/N
33nF			1.25/A				1.6/N	1.6/N	1.6/N
39nF			1.25/A				1.6/N	1.6/N	1.6/N
47nF			1.25/A				1.6/N	1.6/N	1.6/N
56nF			1.25/A				1.6/N	1.6/N	1.6/N
68nF			1.25/A				1.6/N	1.6/N	
100nF			1.25/A				1.6/N	2.0/N	
220nF	1.6/N	1.6/N	1.6/N						
330nF	1.6/N	1.6/N	1.6/N						
470nF	1.6/N	1.6/N	1.6/N						
680nF	1.6/N	1.6/N	1.6/N						
1 uF	1.6/N	1.6/N	1.6/N						
2.2 uF	1.6/N	1.6/N	1.6/N						
3.3 uF	1.6/N	1.6/N	1.6/N						
4.7 uF	1.6/N	1.6/N	1.6/N						
6.8 uF									
10 uF									
100uF				2.0/N					

备注：1、N：Cu/Ni/Sn 三层端头 A：柔性端头
2、可根据客户的特殊要求设计符合客户需求的产品



六、可靠性测试

项目	技术规格		测试方法		
1、容量	COG	应符合指定的误差级别	标称容量	测试频率	测试电压
			$\leq 1000\text{pF}$	$1\text{MHz} \pm 10\%$	$1.0 \pm 0.2\text{Vrms}$
			$> 1000\text{pF}$	$1\text{KHz} \pm 10\%$	
X7R/ X7S/ X7T/ X5R	应符合指定的误差级别	测试温度: $25^\circ\text{C} \pm 3^\circ\text{C}$ $C \leq 10\mu\text{F}$: 测试频率: $1\text{KHz} \pm 10\%$ 测试电压: $1.0 \pm 0.2\text{Vrms}$ $C > 10\mu\text{F}$: 测试频率: $120 \pm 24\text{Hz}$ 测试电压: $0.5 \pm 0.1\text{Vrms}$			
2、绝缘电阻 (IR)	COG	$C \leq 10\text{ nF}, R_i \geq 100000\text{M}\Omega$ $C > 10\text{ nF}, R_i \cdot C_R \geq 1000\text{S}$	测试电压: 额定电压 测试时间: 60 ± 5 秒 测试湿度: $\leq 75\%$ 测试温度: $25^\circ\text{C} \pm 3^\circ\text{C}$ 测试充放电电流: $\leq 50\text{mA}$		
	X7R/ X7S	$C \leq 25\text{ nF}, R_i \geq 10000\text{M}\Omega$ $C > 25\text{ nF}, R_i \cdot C_R \geq 100\text{S}$			
3、介质耐电强度(DWV)	不应有介质被击穿或损伤		$U_r < 100\text{V}$	测量电压: COG: 300%额定电压 X7R/X7S: 250%额定电压 时间: 1~5 秒 充/放电电流: 不应超过 50mA	
			$100 \leq U_r \leq 630\text{V}$	施加额定电压的 200%, 5 秒, 最大电流不超过 50mA	
4、损耗角正切($\text{DF}, \tan \delta$)	CG	DF	标称容量	测试频率	测试电压
		$\leq 0.1\%$	$C_r \geq 30\text{pF}$	$1\text{MHz} \pm 10\%$	$1.0 \pm 0.2\text{Vrms}$
		$\leq 0.15\%$	$C_r < 30\text{pF}$	$1\text{MHz} \pm 10\%$	



项目	技术规格						测试方法		
4、损耗角正切(DF, tan δ)	X7R/ X7S/ X7I/ X5R	电压	DF	0201	0402	0603	0805	1206 及以上	<p>$C \leq 10\mu\text{F}$ 测试频率: 1KHz $\pm 10\%$ 测试电压: $1.0 \pm 0.2\text{Vrms}$</p> <p>$C > 10\mu\text{F}$ 测试频率: $120 \pm 24\text{Hz}$ 测试电压: $0.5 \pm 0.1\text{Vrms}$</p>
		$\geq 100\text{V}$	$\leq 5\%$	—	$\leq 10\text{nF}$	$\leq 100\text{nF}$	$\leq 330\text{nF}$	$\leq 680\text{nF}$	
		50V	$\leq 2.5\%$	$\leq 3.3\text{nF}$	$\leq 10\text{nF}$	$\leq 100\text{nF}$	$\leq 330\text{nF}$	$\leq 680\text{nF}$	
			$\leq 3.5\%$	$\leq 10\text{nF}$	—	—	—	$\leq 1\mu\text{F}$	
			$\leq 5\%$	—	—	—	$\leq 680\text{nF}$	—	
			$\leq 10\%$	—	$\leq 1\mu\text{F}$	$\leq 2.2\mu\text{F}$	$\leq 4.7\mu\text{F}$	$\leq 10\mu\text{F}$	
		25V	$\leq 2.5\%$	$\leq 3.3\text{nF}$	$\leq 10\text{nF}$	$\leq 150\text{nF}$	$\leq 330\text{nF}$	$\leq 680\text{nF}$	
			$\leq 3.5\%$	$\leq 10\text{nF}$	$\leq 100\text{nF}$	$\leq 330\text{nF}$	—	$\leq 2.2\mu\text{F}$	
			$\leq 5\%$	—	—	—	$\leq 1\mu\text{F}$	—	
			$\leq 7.5\%$	—	—	—	$\leq 2.2\mu\text{F}$	$\leq 4.7\mu\text{F}$	
			$\leq 10\%$	$\leq 100\text{nF}$	$\leq 2.2\mu\text{F}$	$\leq 10\mu\text{F}$	$\leq 22\mu\text{F}$	$\leq 22\mu\text{F}$	
		16V	$\leq 2.5\%$	$\leq 3.3\text{nF}$	$\leq 10\text{nF}$	$\leq 150\text{nF}$	$\leq 330\text{nF}$	$\leq 680\text{nF}$	
			$\leq 3.5\%$	$\leq 15\text{nF}$	$\leq 100\text{nF}$	$\leq 330\text{nF}$	—	$\leq 2.2\mu\text{F}$	
			$\leq 5\%$	$\leq 47\text{nF}$	$\leq 220\text{nF}$	$\leq 680\text{nF}$	$\leq 2.2\mu\text{F}$	—	
			$\leq 7.5\%$	—	—	—	$\leq 4.7\mu\text{F}$	$\leq 4.7\mu\text{F}$	
			$\leq 10\%$	$\leq 100\text{nF}$	$\leq 4.7\mu\text{F}$	$\leq 10\mu\text{F}$	$\leq 22\mu\text{F}$	$\leq 47\mu\text{F}$	
		10V	$\leq 2.5\%$	$\leq 3.3\text{nF}$	$\leq 10\text{nF}$	$\leq 150\text{nF}$	$\leq 330\text{nF}$	$\leq 680\text{nF}$	
			$\leq 3.5\%$	$\leq 15\text{nF}$	$\leq 100\text{nF}$	$\leq 330\text{nF}$	—	$\leq 2.2\mu\text{F}$	
			$\leq 5\%$	$\leq 47\text{nF}$	—	$\leq 680\text{nF}$	$\leq 2.2\mu\text{F}$	—	
			$\leq 7.5\%$	—	$\leq 1\mu\text{F}$	$\leq 2.2\mu\text{F}$	$\leq 4.7\mu\text{F}$	$\leq 10\mu\text{F}$	
			$\leq 10\%$	$\leq 2.2\mu\text{F}$	$\leq 10\mu\text{F}$	$\leq 22\mu\text{F}$	$\leq 47\mu\text{F}$	$\leq 100\mu\text{F}$	
		$\leq 6.3\text{V}$	$\leq 2.5\%$	$\leq 3.3\text{nF}$	—	$\leq 150\text{nF}$	—	$\leq 680\text{nF}$	
			$\leq 3.5\%$	$\leq 15\text{nF}$	$\leq 100\text{nF}$	$\leq 330\text{nF}$	—	$\leq 2.2\mu\text{F}$	
			$\leq 5\%$	$\leq 47\text{nF}$	$\leq 220\text{nF}$	$\leq 680\text{nF}$	—	—	
			$\leq 7.5\%$	—	$\leq 1\mu\text{F}$	—	$10\mu\text{F} \sim 22\mu\text{F}$	$\leq 10\mu\text{F}$	
			$\leq 10\%$	$\leq 4.7\mu\text{F}$	$\leq 22\mu\text{F}$	$\leq 47\mu\text{F}$	$\leq 47\mu\text{F}$	$\leq 100\mu\text{F}$	



项目	技术规格			测试方法																	
5、高温存储	项目 Item	C0G	X7R/X7S/ X7T/X5R	温度：最高工作温度 125±2℃ 实验电压：不施加电压 实验时间：1000 小时 放置条件：室温 放置时间：24 小时(I 类)；48 小时(II 类)																	
	Δ C/C	≤±1%或±1pF， 取两者中最大者	-12.5%~ +12.5%																		
	DF	同初始标准																			
	IR	同初始标准																			
6、温度循环	项目	C0G	X7R/X7S/ X7T/X5R	※预处理*（仅针对 2 类电容器）：上限类别温度，1 小时；恢复：24±1h 初始测量 循环次数：1000 次,一个循环分以下 4 步： <table border="1" style="margin-left: 20px;"> <thead> <tr> <th>阶段</th> <th>温度 (℃)</th> <th>时间 (分钟)</th> </tr> </thead> <tbody> <tr> <td>第 1 步</td> <td>下限温度 (C0G/X7R/X7S/X7T/X5R:-55)</td> <td>30</td> </tr> <tr> <td>第 2 步</td> <td>常温 (+20)</td> <td>1</td> </tr> <tr> <td>第 3 步</td> <td>上限温度 (C0G/X7R/X7S/X7T:+125 X5R:+85)</td> <td>30</td> </tr> <tr> <td>第 4 步</td> <td>常温 (+20)</td> <td>1</td> </tr> </tbody> </table> 试验后放置（恢复）时间：24±2h			阶段	温度 (℃)	时间 (分钟)	第 1 步	下限温度 (C0G/X7R/X7S/X7T/X5R:-55)	30	第 2 步	常温 (+20)	1	第 3 步	上限温度 (C0G/X7R/X7S/X7T:+125 X5R:+85)	30	第 4 步	常温 (+20)	1
	阶段	温度 (℃)	时间 (分钟)																		
	第 1 步	下限温度 (C0G/X7R/X7S/X7T/X5R:-55)	30																		
	第 2 步	常温 (+20)	1																		
	第 3 步	上限温度 (C0G/X7R/X7S/X7T:+125 X5R:+85)	30																		
	第 4 步	常温 (+20)	1																		
Δ C/C	≤±1%或±1pF， 取两者中最大者	-10%~+10%																			
DF	同初始标准																				
IR	同初始标准																				
外观：无可见损伤																					
7、温度冲击	项目	C0G	X7R/X7S/ X7T/X5R	※预处理*（仅针对 2 类电容器）：上限类别温度，1 小时；恢复：24±1h 初始测量 循环次数：1000 次 实验方法： 1、样品上板后放置入温冲箱内 2、温度区间为-55℃~上限温度，每个温度点停留时间 15min，温区间转换时间<10s 试验后放置（恢复）时间：24±2h																	
	Δ C/C	≤±1%或±1pF， 取两者中最大者	-10%~+10%																		
	DF	同初始标准																			
	IR	同初始标准																			
	外观：无可见损伤																				
8、破坏性物理分析 (DPA)	无缺陷或异常			按照 EIA-469																	
9、偏高湿度	项目	C0G	X7R/X7S/ X7T/X5R	※预处理（仅针对 2 类电容器）： 在 140℃~150℃下预热 1 小时后，在室温下放置 24 小时。 试验条件：85±2℃，80~85%R.H. 串联一个 100K Ω，施加额定电压，1000 小时																	
	ΔCC	≤±2.5%或±2.5pF,取两者之中较大者。	-12.5%~ +12.5%																		
	DF	同初始标准																			
	IR	同初始标准																			
	外观：无可见损伤																				



项目	技术规格	测试方法															
10、外观	无可见损伤	目视检查															
11、尺寸	在规定尺寸范围内	使用卡尺															
12、振动	<table border="1"> <thead> <tr> <th>项目</th> <th>C0G</th> <th>X7R/X7S/ X7T/X5R</th> </tr> </thead> <tbody> <tr> <td>ΔC/C</td> <td>≤±1%或±1pF, 取两者中最大者</td> <td>-10%~+10 %</td> </tr> <tr> <td>DF</td> <td colspan="2">同初始标准</td> </tr> <tr> <td>IR</td> <td colspan="2">同初始标准</td> </tr> <tr> <td>外观</td> <td colspan="2">无可见损伤</td> </tr> </tbody> </table>	项目	C0G	X7R/X7S/ X7T/X5R	ΔC/C	≤±1%或±1pF, 取两者中最大者	-10%~+10 %	DF	同初始标准		IR	同初始标准		外观	无可见损伤		5g 的力 20 分钟，三个方向每个方向 12 个循环。 注意：使用 8"X5" 印刷线路板，.031"厚，在长的一边有 7 个固定点，在对面的边的角有 2 个固定点。产品在距离固定点 2" 内安装。测试频率从 10-2000 赫兹。
	项目	C0G	X7R/X7S/ X7T/X5R														
	ΔC/C	≤±1%或±1pF, 取两者中最大者	-10%~+10 %														
	DF	同初始标准															
	IR	同初始标准															
外观	无可见损伤																
13、机械冲击	<table border="1"> <thead> <tr> <th>项目</th> <th>C0G</th> <th>X7R/X7S/ X7T/X5R</th> </tr> </thead> <tbody> <tr> <td>ΔC/C</td> <td>≤±1%或±1pF, 取两者中最大者</td> <td>-10%~+10 %</td> </tr> <tr> <td>DF</td> <td colspan="2">同初始标准</td> </tr> <tr> <td>IR</td> <td colspan="2">同初始标准</td> </tr> <tr> <td>外观</td> <td colspan="2">无可见损伤</td> </tr> </tbody> </table>	项目	C0G	X7R/X7S/ X7T/X5R	ΔC/C	≤±1%或±1pF, 取两者中最大者	-10%~+10 %	DF	同初始标准		IR	同初始标准		外观	无可见损伤		应沿试件的 3 个互相垂直轴，在每个方向上实施 3 次冲击试验 (共计 18 次冲击)。 脉冲波形：正弦半波 持续时长：0.5 毫秒 峰值：1500g 速度变化：4.7m/s
	项目	C0G	X7R/X7S/ X7T/X5R														
	ΔC/C	≤±1%或±1pF, 取两者中最大者	-10%~+10 %														
	DF	同初始标准															
	IR	同初始标准															
外观	无可见损伤																
14、寿命试验	<table border="1"> <tbody> <tr> <td>ΔC/C</td> <td>C0G: ≤±2.5%或±2.5pF 取两者之中较大者 X7R/X7S/X7T/X5R: ≤±12.5%</td> </tr> <tr> <td>DF</td> <td>同初始标准</td> </tr> <tr> <td rowspan="2">IR</td> <td>C0G: $R_i \geq 5000M \Omega$ 或 $R_i \cdot C_R \geq 50S$ 取两者之中较小者.</td> </tr> <tr> <td>X7R/X7S/X7T/X5R: $R_i \geq 1000M \Omega$ 或 $R_i \cdot C_R \geq 10S$ 取两者之中较小者.</td> </tr> <tr> <td colspan="2">外观: 无损伤</td> </tr> </tbody> </table>	ΔC/C	C0G: ≤±2.5%或±2.5pF 取两者之中较大者 X7R/X7S/X7T/X5R: ≤±12.5%	DF	同初始标准	IR	C0G: $R_i \geq 5000M \Omega$ 或 $R_i \cdot C_R \geq 50S$ 取两者之中较小者.	X7R/X7S/X7T/X5R: $R_i \geq 1000M \Omega$ 或 $R_i \cdot C_R \geq 10S$ 取两者之中较小者.	外观: 无损伤		电压: $U_r < 500V$: 2 倍额定电压 $500V \leq U_r \leq 630V$: 1.5 倍额定电压 $U_r > 630V$: 1 倍额定电压 时间: 1000 小时 温度: 125℃ 充电电流: 不应超过 50mA 放置条件: 室温 放置时间: 24 小时 (C0G), 或 48 小时 (X7R/X7S/X7T/X5R:),						
	ΔC/C	C0G: ≤±2.5%或±2.5pF 取两者之中较大者 X7R/X7S/X7T/X5R: ≤±12.5%															
	DF	同初始标准															
	IR	C0G: $R_i \geq 5000M \Omega$ 或 $R_i \cdot C_R \geq 50S$ 取两者之中较小者.															
X7R/X7S/X7T/X5R: $R_i \geq 1000M \Omega$ 或 $R_i \cdot C_R \geq 10S$ 取两者之中较小者.																	
外观: 无损伤																	

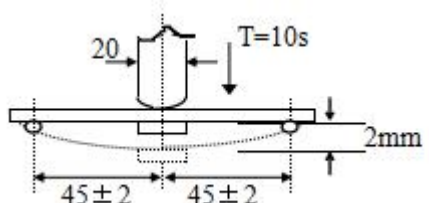
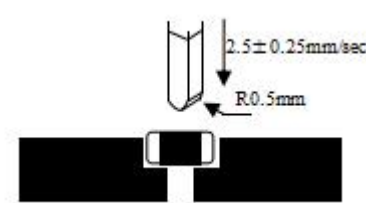

项目	技术规格			测试方法
15、耐焊接热	项目 Item	COG	X7R/X7S/ X7T/X5R	将电容在 100~200℃ 的温度下预热 60~120 秒。 浸锡温度: 265±5℃ 浸锡时间: 10±1s 然后取出溶剂清洗干净,在 10 倍以上的显微镜底下观察 放置时间: 24±2 小时 放置条件: 室温
	ΔCC	≤ ± 1% 或 ± 1pF, 取两者之中较大者。	-15%~ +15%	
	DF	同初始标准		
	IR	同初始标准		
	外观: 无可见损伤 上锡率: ≥95%			
16、静电放电 ESD	项目	COG	X7R/X7S	条件: 接触放电; 放电电压: 2000V 每个样品每个电极承受两次放电, 正、负级性各 1 次
	C	同初始标准		
	DF	同初始标准		
	IR	同初始标准		
	外观	无可见损伤		
17、可焊性	上锡率应大于 95% 外观: 无可见损伤.			将电容在 80~120℃ 的温度下预热 10~30 秒.
				有铅焊料: (Sn/Pb: 63/37) 浸锡温度: 235±5℃ 浸锡时间: 2±0.5s
18、抗弯曲强度	项目	COG	X7R/X7S	试验基板: Al ₂ O ₃ 或 PCB 弯曲深度: 2mm 施压速度: 1mm/sec.; 单位: mm 应在弯曲状态下进行测量。 
	ΔCC	≤ ± 1% 或 ± 1pF, 取两者之中较大者。	-10%~+10 %	
	DF	同初始标准		
	IR	同初始标准		
	外观: 无损伤.			
19、射束负载 (断裂强度)	规格	产品厚度	最小受力	如图所示 产品在测试过程中瓷体断裂时所受力必须大于最小承受力。 
	≤AM05	> 0.5mm	20N	
		≤0.5mm	8N	
	≥AM06	≥1.25mm	54N	
		< 1.25mm	15N	



项目	技术规格	测试方法																							
20、端子强度 (SMD)	<table border="1"> <thead> <tr> <th>项目 Item</th> <th>C0G</th> <th>X7R/X7S</th> </tr> </thead> <tbody> <tr> <td>$\Delta C/C$</td> <td>$\leq \pm 0.5\%$</td> <td>$-10\% \sim +10\%$</td> </tr> <tr> <td>DF</td> <td colspan="2">同初始标准</td> </tr> <tr> <td>IR</td> <td colspan="2">同初始标准</td> </tr> <tr> <td>外观</td> <td colspan="2">无可见损伤</td> </tr> </tbody> </table>	项目 Item	C0G	X7R/X7S	$\Delta C/C$	$\leq \pm 0.5\%$	$-10\% \sim +10\%$	DF	同初始标准		IR	同初始标准		外观	无可见损伤		<p>如图所示 慢慢施加一个 T 的力到电容侧面瓷体上，并保持 60+1 秒。</p> <table border="1"> <thead> <tr> <th>规格 Type</th> <th>施加力 T</th> </tr> </thead> <tbody> <tr> <td>AM02</td> <td>2N</td> </tr> <tr> <td>AM03</td> <td>10N</td> </tr> <tr> <td>>AM03</td> <td>17.7N</td> </tr> </tbody> </table>	规格 Type	施加力 T	AM02	2N	AM03	10N	>AM03	17.7N
	项目 Item	C0G	X7R/X7S																						
$\Delta C/C$	$\leq \pm 0.5\%$	$-10\% \sim +10\%$																							
DF	同初始标准																								
IR	同初始标准																								
外观	无可见损伤																								
规格 Type	施加力 T																								
AM02	2N																								
AM03	10N																								
>AM03	17.7N																								
21、温度特性	<table border="1"> <thead> <tr> <th>项目 Item</th> <th>$\Delta C/C$</th> </tr> </thead> <tbody> <tr> <td>C0G</td> <td>$\pm 0.2\%$或$\pm 0.05\text{pF}$</td> </tr> <tr> <td>X7R</td> <td>$\pm 15\%$</td> </tr> <tr> <td>X7S</td> <td>$\pm 22\%$</td> </tr> <tr> <td>X7T</td> <td>$-33\% \sim +22\%$</td> </tr> </tbody> </table>	项目 Item	$\Delta C/C$	C0G	$\pm 0.2\%$ 或 $\pm 0.05\text{pF}$	X7R	$\pm 15\%$	X7S	$\pm 22\%$	X7T	$-33\% \sim +22\%$	<p>在-55℃、20℃、125℃三个温度点分别测量产品电性能</p>													
项目 Item	$\Delta C/C$																								
C0G	$\pm 0.2\%$ 或 $\pm 0.05\text{pF}$																								
X7R	$\pm 15\%$																								
X7S	$\pm 22\%$																								
X7T	$-33\% \sim +22\%$																								

七、包装

● 纸带卷盘结构

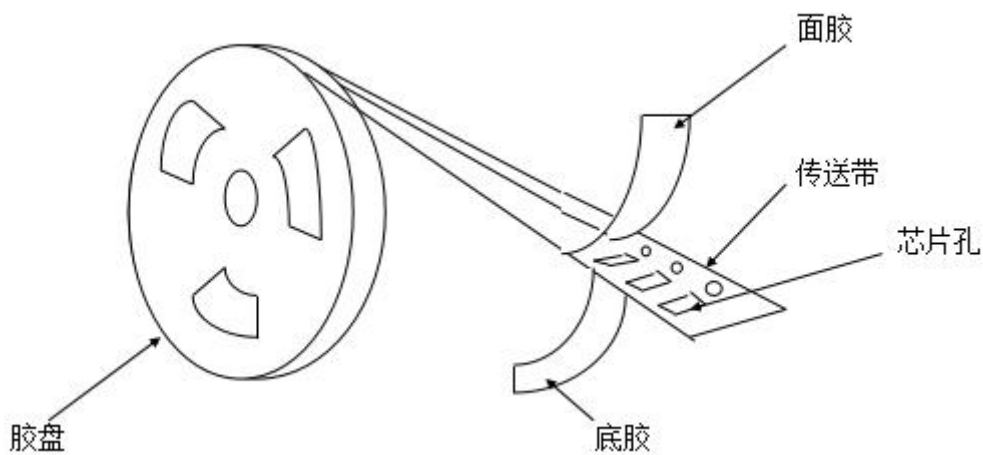



※ AM01、AM02 纸带编带尺寸大小

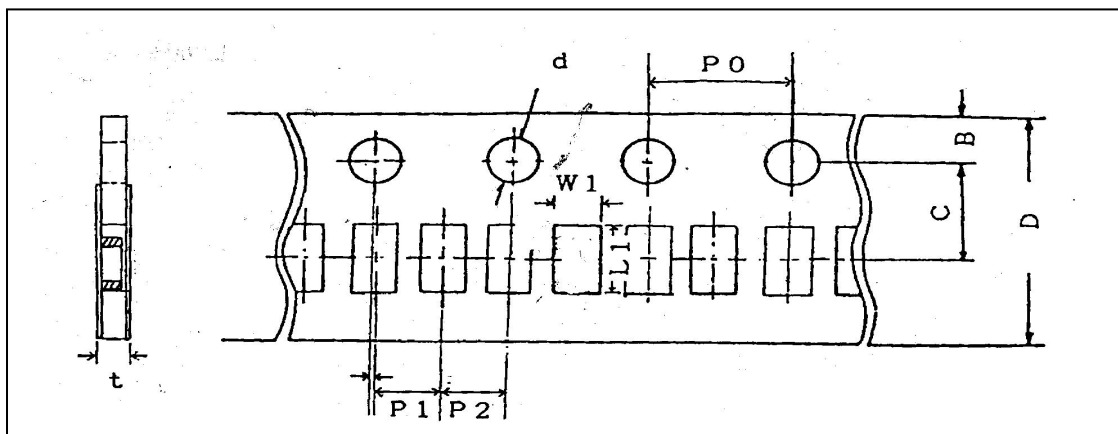

Unit: mm

代号 纸带规格	W1	L1	D	C	B	P1	P2	P0	d	t
AM01	0.37± 0.10	0.67±0 .10	8.00± 0.10	3.50± 0.05	1.75± 0.10	2.00± 0.05	2.00± 0.05	4.00± 0.10	1.50 -0/+0.10	0.80 Below
AM02	0.65± 0.10	1.15± 0.10	8.00± 0.10	3.50± 0.05	1.75± 0.10	2.00± 0.05	2.00± 0.05	4.00± 0.10	1.50 -0/+0.10	0.80 Below

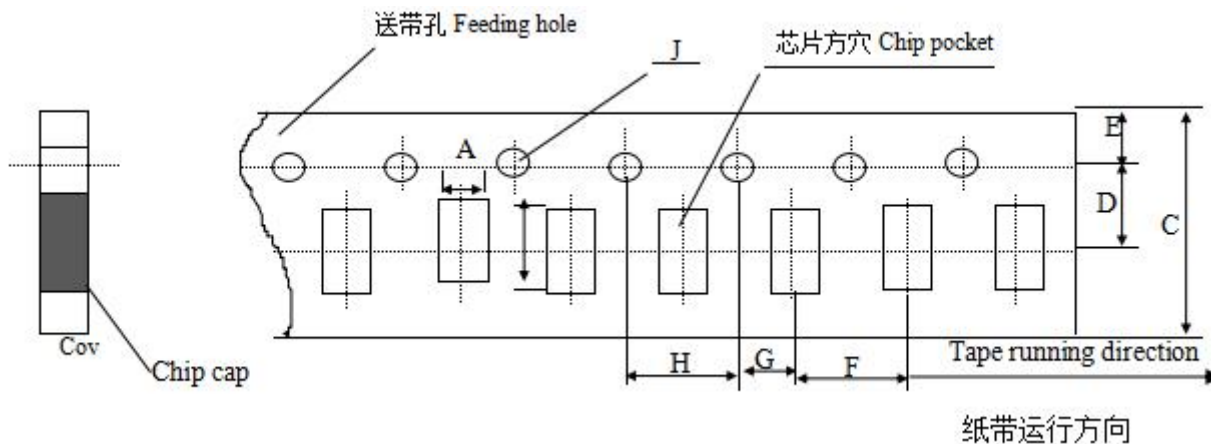

※ 适合 ‘AM03, AM05, AM06’ 常规尺寸产品的纸带尺寸

Unit: mm

代号 纸带规格	A	B	C	D*	E	F	G*	H	J	T
AM03	1.10 ±0.10	1.90 ±0.10	8.00 ±0.10	3.50 ±0.05	1.75 ±0.10	4.00 ±0.10	2.00 ±0.10	4.00 ±0.10	1.50 -0/+0.10	1.10 Max
AM05	1.45 ±0.15	2.30 ±0.15	8.00 ±0.15	3.50 ±0.05	1.75 ±0.10	4.00 ±0.10	2.00 ±0.10	4.00 ±0.10	1.50 -0/+0.10	1.10 Max
AM06	1.80 ±0.20	3.40 ±0.20	8.00 ±0.20	3.50 ±0.05	1.75 ±0.10	4.00 ±0.10	2.00 ±0.10	4.00 ±0.10	1.50 -0/+0.10	1.10 Max

注意：*表示此处对尺寸的要求非常精确。



● 塑胶卷盘结构

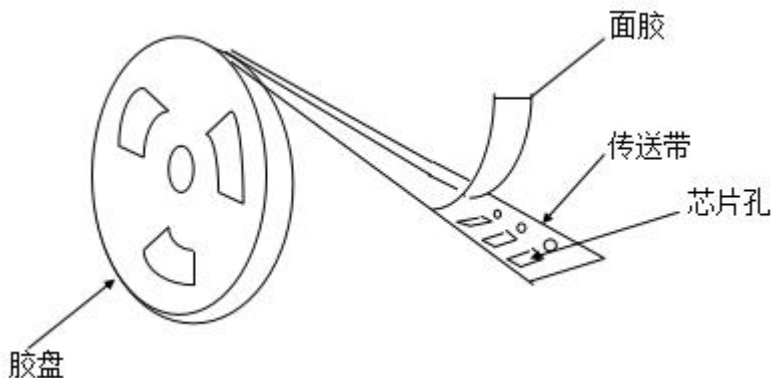

※ 塑胶带尺寸结构(适合‘AM05~AM20’型产品)

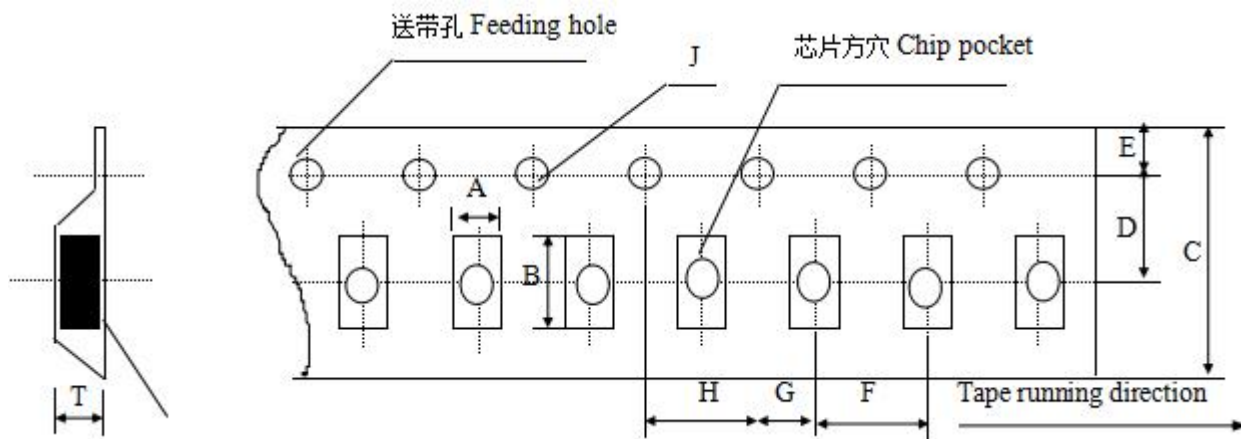

Unit: mm

代号 规格	A	B	C	D*	E	F	G*	H	J	T
AM05	1.55 ± 0.20	2.35 ± 0.20	8.00 ± 0.20	3.50 ± 0.05	1.75 ± 0.10	4.00 ± 0.10	2.00 ± 0.10	4.00 ± 0.10	1.50 -0/+0.10	1.50 Max
AM06	1.95 ± 0.20	3.60 ± 0.20	8.00 ± 0.20	3.50 ± 0.05	1.75 ± 0.10	4.00 ± 0.10	2.00 ± 0.10	4.00 ± 0.1	1.50 -0/+0.10	1.85 Max
AM10	2.70 ± 0.10	3.42 ± 0.10	8.00 ± 0.10	3.50 ± 0.05	1.75 ± 0.10	4.00 ± 0.10	2.00 ± 0.05	4.00 ± 0.10	1.55 -0/+0.10	3.2 Max
AM08	2.20 ± 0.10	4.95 ± 0.10	12.00 ± 0.10	5.50 ± 0.05	1.75 ± 0.10	4.00 ± 0.10	2.00 ± 0.05	4.00 ± 0.10	1.50 -0/+0.10	3.0 Max
AM12	3.66 ± 0.10	4.95 ± 0.10	12.00 ± 0.10	5.50 ± 0.05	1.75 ± 0.10	8.00 ± 0.10	2.00 ± 0.05	4.00 ± 0.10	1.55 -0/+0.10	4.0 Max
AM20	6.2 ± 0.1	6.7 ± 0.1	12.00 ± 0.10	5.50 ± 0.05	1.75 ± 0.10	8.00 ± 0.10	2.00 ± 0.05	4.00 ± 0.10	1.55 -0/+0.10	2.4 ± 0.10

备注：*表示此处对尺寸的要求非常精确。



● 传送带的前后结构

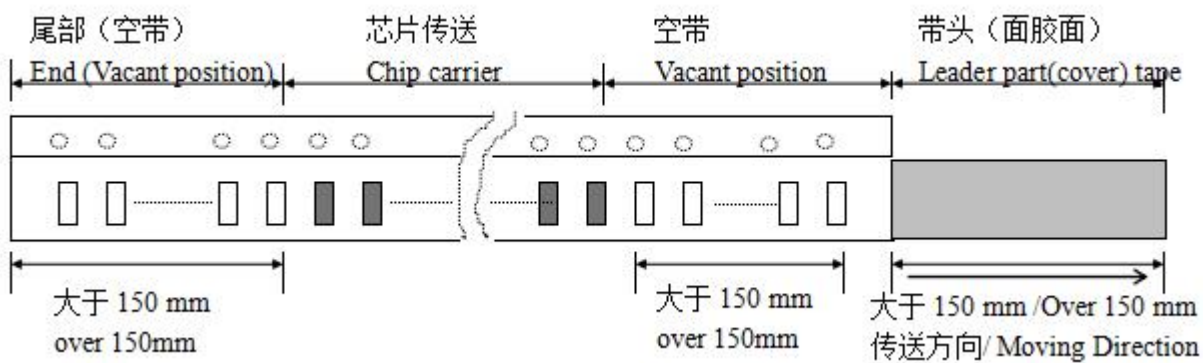

● 卷盘尺寸 (unit: mm)

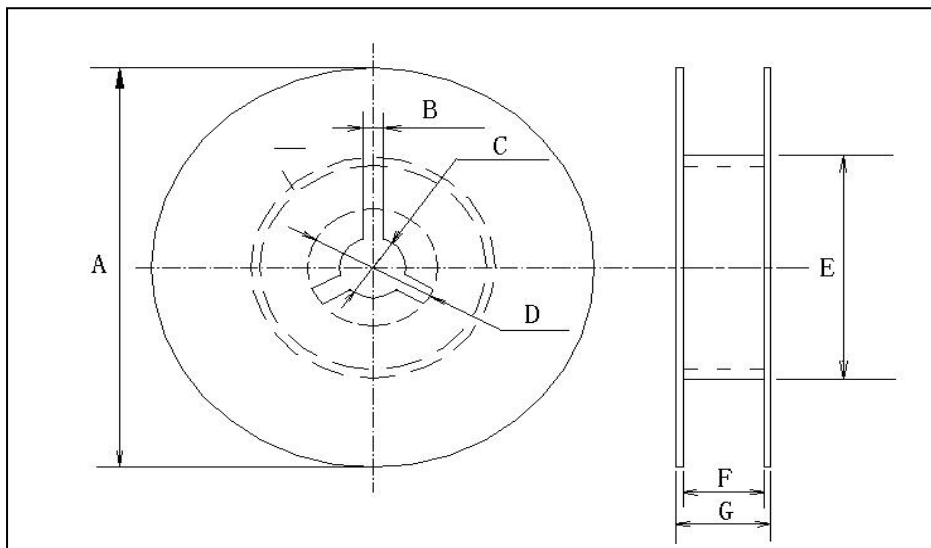

● 尺寸代码 (CODE)

卷盘型号	A	B	C	D	E	F	G
7 REEL	$\phi 178 \pm 2.0$	3.0	$\phi 13 \pm 0.5$	$\phi 21 \pm 0.8$	$\phi 50$ 或更大	100 ± 1.5	12max
13' REEL	$\phi 330 \pm 2.0$	3.0	$\phi 13 \pm 0.5$	$\phi 21 \pm 0.8$	$\phi 50$ 或更大	100 ± 1.5	12max



● 关于卷带的说明

※ 面胶剥离强度

(a) 纸带

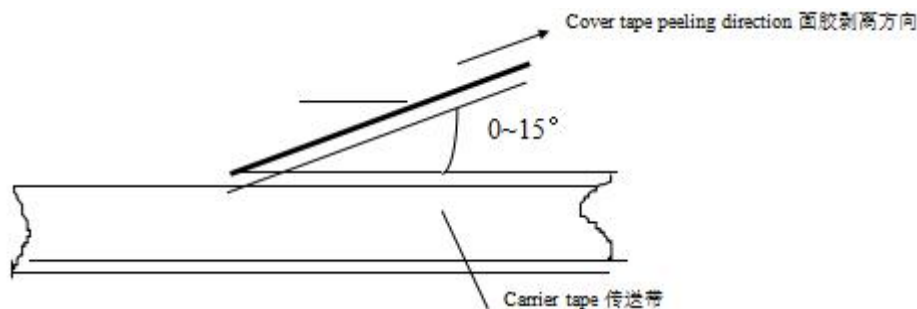

(b) 塑料胶盘

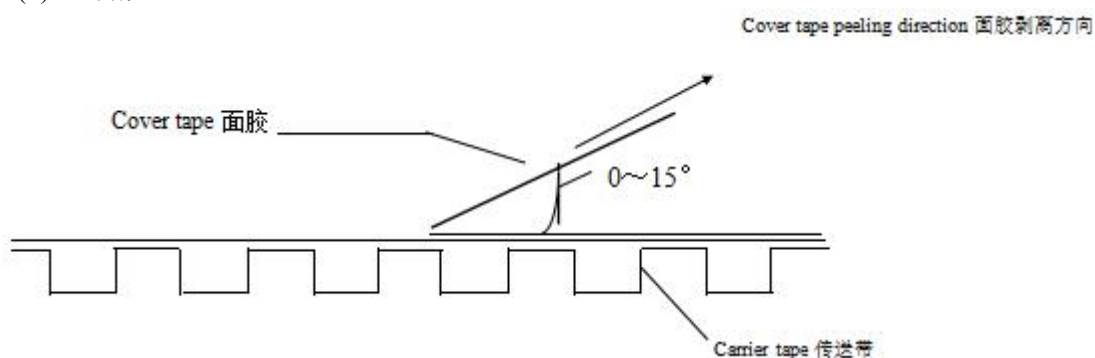

标准：0.1N<剥离强度<0.7N

在剥离时，纸带不能有纸碎，也不能粘在底、面胶上。

※ 塑料盒散包装

单位 (unit) :mm

Symbol	A	B	T	C	D	E
Dimension	6.80±0.10	8.80±1.00	12.00±0.10	15.00+0.10/-0	2.00+0/-0.10	4.70±0.10
Symbol	F	W	G	H	L	I
Dimension	31.50+0.20/-0	36.00+0/-0.20	19.00±0.35	7.00±0.35	110.00±0.70	5.00±0.35

※ 包装数量

尺寸	包装形式和数量 unit: pcs			
	纸带卷盘 (PT)	胶带卷盘 (ET)	塑料盒散装 (BC)	一般散装 (BP)
AM01	15000	-----	-----	-----
AM02	10000	-----	20000	5000
AM03	4000	-----	15000	5000
AM05	4000	3000	10000	5000
AM06	4000	T≤1.35mm 3000 T>1.35mm 2000	5000	5000
AM10	-----	T≤1.80mm 2000 T>1.80mm 1000	-----	2000
AM08	-----	2000	-----	2000
AM12	-----	T≤1.85mm 1000 T>1.85mm 500	-----	2000
AM20	-----	500	-----	-----

注意：包装的形式和数量可根据客户的要求来定。



●外包装

小包装

数量：10卷

大包装

数量：6盒

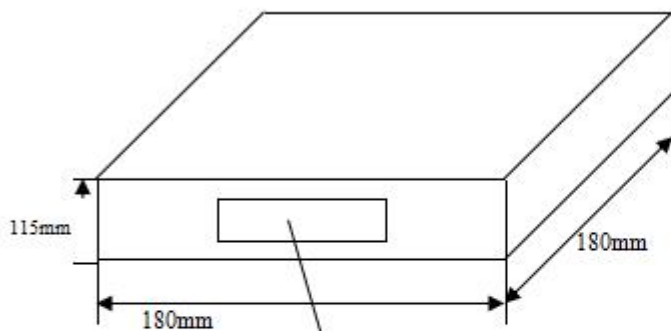

Label 标签

PART No 型号规格
QUANTITY 数量
DATE日期

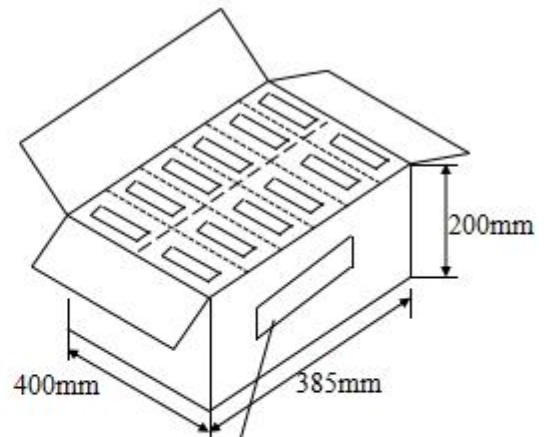

Label 标签

Production name 产品名称
Quantity 数量
Weight 重量

八、储存方法

确保芯片可焊性良好的贮存期限为12个月(在包装好已交付的情况下)。

储存条件：

储存温度 5~40℃

储存相对湿度 20~70%

九、使用前的注意事项

多层片式瓷介电容器(MLCC)在短路或开路的电路中都有可能失效,在超出本承认书或相关说明书中所述使用频率的恶劣工作环境,或外界机械力超压作用下,电容芯片都有可能着火、燃烧甚至爆炸,所以在使用的时候,首先应考虑按本承认书的有关说明来进行,如有不明之处,请联系我们技术部、品管部或生产部。

1. 焊接的条件与相关图表

为避免因温度的突然变化而引起的芯片开裂或局部爆炸的现象发生,请按有关温度曲线图表来进行。

2. 手工焊接

手工焊接很容易因为芯片局部受热不均而引起瓷体微裂或局部爆炸的现象,在焊接时,如果操作者不小心,会使烙铁头直接同电容芯片的瓷体部分接触,这样很容易使电容芯片因热冲击而受损或出现其他意外.因此,使用电烙铁手工焊接时应仔细操作,并对电烙铁的尖端的选择和尖端温度控制应多加小心。



3. 适量的焊料

焊料过多

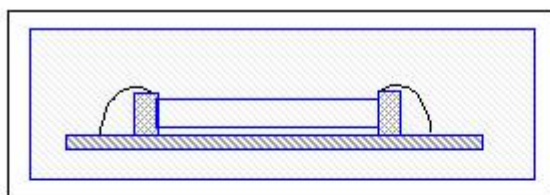

这样会因端头压力过大而可能引起芯片受损

焊料太少

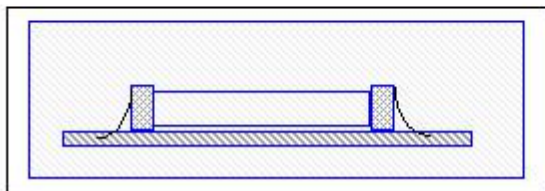

固定力量不足,可能会引起电容芯片与线路接触不良

4. 推荐焊料用量

4.1 回流焊接的最佳焊料用量

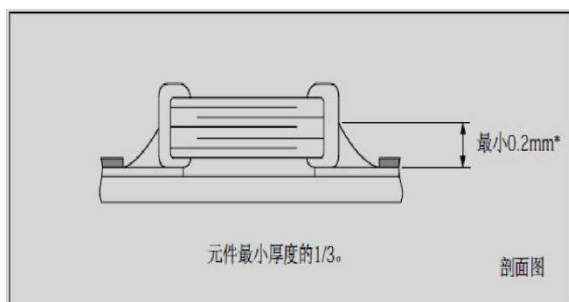

4.2 使用烙铁返修时的最佳焊料量

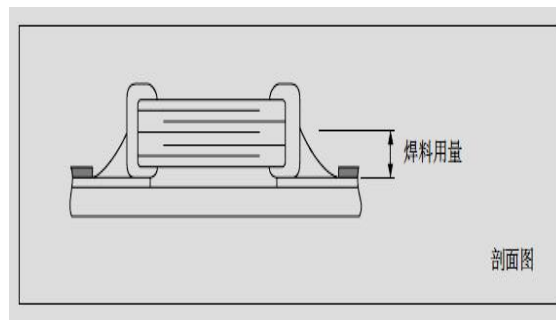

十、推荐焊接方式

规格尺寸	温度特性	焊接方式		温度特性	焊接方式
AM01	NPO	R	AM05	NPO	R
	X7R /X7S/X7T/X5R	R		X7R /X7S/X7T/X5R	R
AM02	NPO	R	AM06	NPO	R
	X7R /X7S/X7T/X5R	R		X7R /X7S/X7T/X5R	R
AM03	NPO	R	≥AM10	NPO	R
	X7R /X7S/X7T/X5R	R		X7R /X7S/X7T/X5R	R

焊接方式：R—回流焊 Reflow Solering



十一、推荐焊接温度曲线图

回流焊接

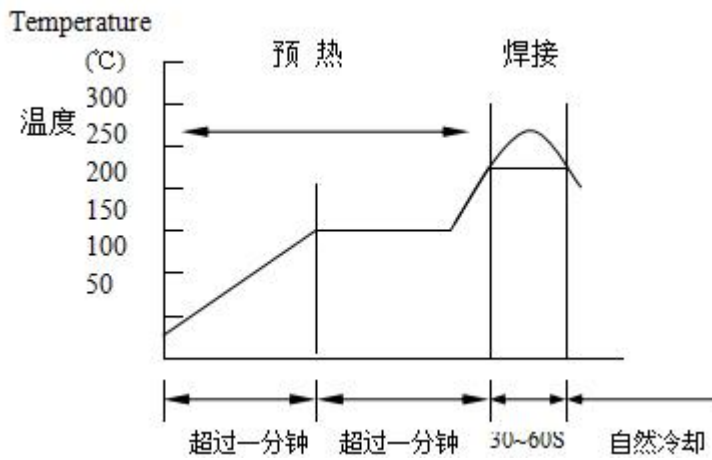

	Pb-Sn 焊接	无铅焊接
尖峰温度	230°C~250°C	240°C~260°C

在预热时，请将焊接温度与芯片表面温度之间的温差维持在 $T \leq 150^\circ\text{C}$ 。

手工焊接

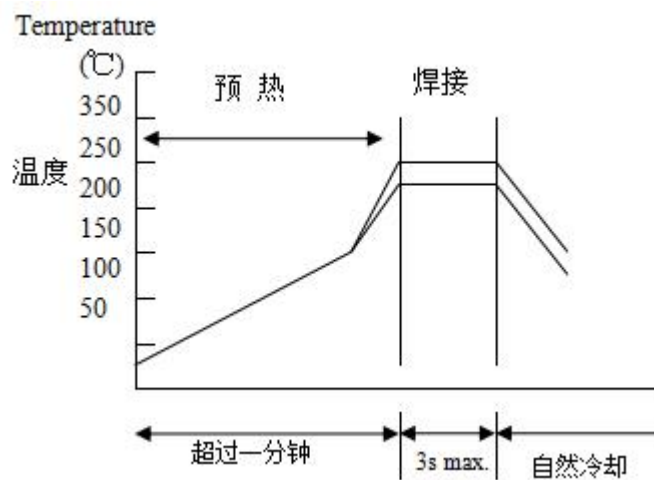

条件：

预热	烙铁头温度	烙铁功率	烙铁头直径	焊接时间	锡膏量	限制条件
$\Delta \leq 130^\circ\text{C}$	最高350°C	最大20W	建议1mm	最长3s	$\leq 1/2$ 芯片厚度	请勿使用烙铁头直接接触陶瓷元件

※以最新版本的内容为准

X-ON Electronics

Largest Supplier of Electrical and Electronic Components

Click to view similar products for [Multilayer Ceramic Capacitors MLCC - SMD/SMT](#) category:

Click to view products by [Fenghua Advanced](#) manufacturer:

Other Similar products are found below :

[M39014/02-1218V](#) [M39014/02-1225V](#) [M39014/22-0631](#) [D55342E07B523DR-T/R](#) [NIN-FC2R7JTRF](#) [NMC0402NPO220J50TRPF](#)
[NMC0402X5R105K6.3TRPF](#) [NMC0402X5R224K6.3TRPF](#) [NMC0402X7R103J25TRPF](#) [NMC0402X7R392K50TRPF](#)
[NMC0603NPO101F50TRPF](#) [NMC0603NPO201J50TRPF](#) [NMC0603NPO330G50TRPF](#) [NMC0603NPO331F50TRPF](#)
[NMC0603X5R475M6.3TRPF](#) [NMC0603X7R333K16TRPF](#) [NMC0805NPO220J100TRPF](#) [NMC0805NPO820J50TRPF](#)
[NMC0805X7R224K25TRPF](#) [NMC1206X7R102K50TRPF](#) [NMC1206X7R106K10TRPLPF](#) [NMC-H0805X7R472K250TRPF](#)
[C1608C0G2A221J](#) [C1608X7R1E334K](#) [C2012C0G2A472J](#) [2220J2K00562KXT](#) [CCR06CG153FSV](#) [CDR04BX104AKSR](#)
[CDR33BX104AKUR](#) [CDR33BX683AKUS](#) [CGA3E1X7R1C684K](#) [CL10C0R8BB8ANNC](#) [M55342H06B20G0R-T/R](#) [C1005X5R0G225M](#)
[C2012X7R2E223K](#) [C3216C0G2J272J](#) [D55342E07B35E7R-T/R](#) [CDR34BX563BKUS](#) [CDR34BX563BKWS](#) [NMC0402NPO220F50TRPF](#)
[NMC0402X7R562J25TRPF](#) [NMC0603NPO102J25TRPF](#) [NMC1206X7R332K50TRPF](#) [NMC-P1206X7R104K250TRPLPF](#) [726632-1](#)
[CGA6M3X7R1H225K](#) [CGA5L2X7R2A105K](#) [CGA3E2X8R1H223K](#) [CDR33BX823AKUR\M500](#) [CDR33BP132BJUR](#)