



承 认 书

APPROVAL SHEET

客户名称 : _____

产品名称: _____ **车规多层片式陶瓷电容器** _____

尺 寸: _____ **AM01~AM20** _____

版 本 : _____

日 期: _____

制 造 MANUFACTURER			客 户 CUSTOMER		
拟制 DESIGN	审核 CHECK	批准 APPROVAL	检验 INSPECTOR	审核 CHECK	批准 APPROVAL



一、概述

● 产品概述

- 1、此类电容器为汽车专用电子元器件，已通过 AEC-Q200 标准设定的所有实验条件，在汽车使用过程中更具稳定性、安全性。
- 2、材料使用主要有温度稳定性能较高的 C0G 以及高介电常数的 X7R、X5R、X7S、X7T。
- 3、适用于引擎 ECU 等的驱动系统控制、安全气囊、ABS 等的安全控制装置。

二、型号规格表示方法

 A M 05 CG 101 J 500 N T
 ① ② ③ ④ ⑤ ⑥ ⑦ ⑧ ⑨

※说明：

①A：汽车电子产品

②M：汽车产品系列，应用分类代码

代号	应用描述
U	满足 AEC-Q200，用于车内信息、多媒体、导航、装饰等通用的舒适娱乐模块； 禁用于涉及安全模块的应用，如 ABS、电池、动力传输等
M	满足 AEC-Q200，适用于引擎 ECU 等的驱动系统控制、安全气囊、ABS 等的安全控制装置；
E	满足 AEC-Q200，采用树脂端头工艺，更有效有效抑制板间弯曲产生的应力裂纹，适用于车载电源控制、电池线等易弯曲模块、动力传输模块。
P	满足 AEC-Q200，开路模式产品设计，可以避免开裂导致的瞬间短路烧毁。适用于汽车电池线、动力传输模块。
S	满足符合 IEC60384-14/AEC-Q200 标准，适用于电池充电器、变频器、DC-DC 转换器等



③尺寸

单位: inch/ mm

尺寸规格	01	02	03	05	06	10	08	12	20
长×宽 inch	0.02×0.01	0.04×0.02	0.06×0.03	0.08×0.05	0.12×0.06	0.12×0.10	0.18×0.08	0.18×0.12	0.22×0.20
长×宽 mm	0.60×0.30	1.00×0.50	1.60×0.80	2.00×1.25	3.20×1.60	3.20×2.50	4.50×2.00	4.50×3.20	5.70×5.00

④ 介质种类

介质种类	CG	B	BS	BT	X
介质材料	COG	X7R	X7S	X7T	X5R

⑤ 标称容量

单位(unit): Pf

表示方式	实际值	注: 头两位数字为有效数字, 第三位数字为0的个数; R为小数点。
0R5	0.5	
1R0	1.0	
102	10×10^2	
224	22×10^4	
...	...	

⑥ 容量误差

代码	A	B	C	D	F	G	J	K	M
误差	±0.05pF	±0.10pF	±0.25pF	±0.5pF	±1.0%	±2.0%	±5.0%	±10%	±20%

备注: A、B、C、D级误差适用于容量≤10pF的产品。

⑦ 额定电压

单位: V

表示方式	实际值	注: 头两位数字为有效数字, 第三位数字为0的个数; R为小数点。
6R3	6.3	
500	50×10^0	
201	20×10^1	
102	10×10^2	
...	...	



⑧ 端头材料

代码	端头类型
N	Cu/Ni/Sn 三层端头
A	柔性端头

备注：具体规格端头类型见容量详情列表

⑨ 包装方式

B	T
散包装	编带包装

三、温度系数/特性

介质种类	参考温度点	标称温度系数	工作温度范围
C0G	20°C	0±30 ppm/°C	-55°C~125°C
X5R	20°C	±15%	-55°C~85°C
X7R	20°C	±15%	-55°C~125°C
X7S	20°C	±22%	-55°C~125°C
X7T	20°C	-33%~22%	-55°C~125°C

备注：I类电容器标称温度系数和允许偏差是采用温度在 20°C 和 85°C 之间的电容量变化来确定的，而 II 类电容器标称温度系数是按照工作范围之间的电容量相对 20°C 的电容量变化来确定的。

四、尺寸及结构

※ 结构

项目	Cu/Ni/Sn 三层端头产品结构	柔性端头产品结构
结构示意图		
代码描述	① 陶瓷介质 ② 镍电极 ③ 铜电极层 ④ 镍镀层 ⑤ 锡镀层	① 陶瓷介质 ② 镍电极 ③ 铜电极层 ④ 导电性树脂 ⑤ 镍镀层 ⑥ 锡镀层



※ 尺寸

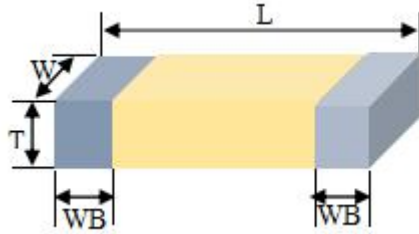

型号	英制表示	公制表示	尺寸 (mm)				备注
			L	W	T	WB	
01	0201	0603	0.6 ± 0.03	0.3 ± 0.03	0.3 ± 0.03	0.15 ± 0.05	$C \leq 47\text{nF}$
			0.6 ± 0.05	0.3 ± 0.05	0.3 ± 0.05	0.15 ± 0.05	$C > 47\text{nF}$
02	0402	1005	1.00 ± 0.05	0.50 ± 0.05	0.50 ± 0.05	0.25 ± 0.05	$C < 1\mu\text{F}$
			1.00 ± 0.15	0.50 ± 0.15	0.50 ± 0.15	0.25 ± 0.05	$1\mu\text{F} \leq C < 10\mu\text{F}$
03	0603	1608	1.60 ± 0.10	0.80 ± 0.10	0.80 ± 0.10	0.35 ± 0.20	$C \leq 1\mu\text{F}$
			1.60 ± 0.20	0.80 ± 0.20	0.80 ± 0.20	0.35 ± 0.20	$C > 1\mu\text{F}$
05	0805	2012	2.00 ± 0.20	1.25 ± 0.20	0.80 ± 0.20	0.50 ± 0.20	$C \leq 0.47 \mu\text{F}$
					1.25 ± 0.20	0.50 ± 0.20	$C > 0.47 \mu\text{F}$
06	1206	3216	3.20 ± 0.30	1.60 ± 0.30	0.80 ± 0.20	0.60 ± 0.30	---
					1.25 ± 0.20		
					1.60 ± 0.30		
10	1210	3225	3.20 ± 0.30	2.50 ± 0.30	≤ 2.80	0.60 ± 0.30	---
08	1808	4520	4.50 ± 0.40	2.00 ± 0.20	≤ 2.20	0.60 ± 0.30	---
12	1812	4532	4.50 ± 0.40	3.20 ± 0.30	≤ 3.50	0.60 ± 0.30	---
20	2220	5750	5.70 ± 0.40	5.00 ± 0.40	≤ 3.50	0.60 ± 0.30	---

备注：可根据客户的特殊要求设计符合客户需求的产品。



五、容量范围及其电压

I类电容器具体电压对应容量及厚度情况列表

AM01、AM02、AM03 规格 N 端头产品

材料	C0G					
	01 (0.6mm*0.3mm)	02 (1.0mm*0.5mm)		03 (1.6mm*0.8mm)		
尺寸	50V	50V	100V	50V	100V	250V
电压	50V	50V	100V	50V	100V	250V
0.1pF	0.3±0.03	0.50±0.05	0.50±0.05	0.80±0.10	0.80±0.10	0.80±0.10
0.2pF						
0.5pF						
1pF						
1.2pF						
1.5pF						
1.8pF						
2.0pF						
2.2pF						
2.7pF						
3.0pF						
3.3pF						
3.6pF						
3.9pF						
4.7pF						
5.0pF						
5.6pF						
6.8pF						
8.0pF						
8.2pF						
10pF						
12pF						
15pF						
18pF						
22pF						
27pF						
33pF						
39pF						
47pF						
56pF						
68pF						
100pF						
120pF						
150pF						
180pF		0.50±0.05		0.80±0.10	0.80±0.10	0.80±0.10
220pF						
270pF						
330pF						
390pF						
470pF						
560pF		0.50±0.05		0.80±0.10	0.80±0.10	
680pF						
1nF						
1.5nF						
1.8nF				0.80±0.10		
2.2nF						
2.7nF						
3.3nF						
4.7nF						

备注：1、对应产品设计厚度，单位：mm

2、可根据客户的特殊要求设计符合客户需求的产品



AM05、AM06 规格 N 端头产品

材料	C0G									
	05 (2.0mm*1.25mm)				06 (3.2mm*1.6mm)					
尺寸	50V	100V	250V	500V	50V	100V	250V	500V	1000V	2000V
0.5pF										
1pF										
1.2pF										
1.5pF										
1.8pF										
2.0pF										
2.2pF										
2.7pF										
3.0pF										
3.3pF										
3.6pF										
3.9pF										
4.7pF										
5.0pF										
5.6pF										
6.8pF	0.80	0.80	0.80	0.80						
8.0pF	±0.20	±0.20	±0.20	±0.20	0.80	0.80	0.80	1.25±0.20	1.25	
8.2pF					±0.20	±0.20	±0.20		±0.20	
10pF										
12pF										
15pF										
18pF										
22pF										
27pF										
33pF										
39pF										
47pF										
56pF										
68pF										
100pF										
120pF										
150pF										
180pF	0.80	0.80	0.80	1.25						
220pF	±0.20	±0.20	±0.20	±0.20						
270pF				1.25						
330pF	0.80	0.80	0.80	±0.20	0.80	0.80	0.80	1.25±0.20	1.25	
390pF	±0.20	±0.20	±0.20		±0.20	±0.20	±0.20		±0.20	
470pF										
560pF										
680pF	0.80	0.80	0.80		0.80	0.80	0.80	1.25±0.20	1.60	
1nF	±0.20	±0.20	±0.20		±0.20	±0.20	±0.20	1.60±0.30	±0.30	
1.5nF										
1.8nF					1.25	1.25	1.25			
2.2nF	0.80				±0.20	±0.20	±0.20			
2.7nF	±0.20									
3.3nF					1.25					
4.7nF					±0.20					

备注：1、对应产品设计厚度，单位：mm

2、可根据客户的特殊要求设计符合客户需求的产品



AM10、AM08 规格 N 端头产品

材料	C0G								
	10 (3.2mm*2.5mm)				08 (4.5mm*2.0mm)				
尺寸	250V	500V	1000V	2000V	250V	500V	1000V	2000V	3000V
电压	250V	500V	1000V	2000V	250V	500V	1000V	2000V	3000V
1pF									
1.2pF									
1.5pF	1.25±0.2	1.25±0.2	1.25±0.2		1.60±0.3	1.60±0.3	1.60±0.3		
1.8pF									
2.0pF									
2.2pF									
2.7pF									
3.0pF									
3.3pF									
3.6pF									
3.9pF									
4.7pF									
5.0pF									
5.6pF									
6.8pF									
8.0pF									
8.2pF									
10pF									
12pF	1.25±0.2	1.25±0.2	1.25±0.2	1.60±0.3	1.60±0.3	1.60±0.3	1.60±0.3	1.60±0.3	1.60±0.3
15pF									
18pF									
22pF									
27pF									
33pF									
39pF									
47pF									
56pF									
68pF									
100pF									
120pF									
150pF									
180pF									
220pF									
270pF	1.25±0.2	1.25±0.2	1.60±0.3						
330pF									
390pF									
470pF	1.25±0.2	1.25±0.2			1.60±0.3	1.60±0.3	1.60±0.3		
560pF									
680pF									
1nF									
1.5nF	1.25±0.2	1.60±0.3			1.60±0.3	1.60±0.3			
1.8nF		2.00±0.3							
2.2nF									
2.7nF	1.60±0.3				1.60±0.3				
3.3nF									
3.9nF									
4.7nF									

备注：1、对应产品设计厚度，单位：mm

2、可根据客户的特殊要求设计符合客户需求的产品



AM12、AM20 规格 N 端头产品

材料	COG									
	12 (4.5mm*3.2mm)					20 (5.7mm*5.0mm)				
尺寸	250V	500V	1000V	2000V	3000V	250V	500V	1000V	2000V	3000V
1pF										
1.2pF										
1.5pF										
1.8pF										
2.0pF										
2.2pF										
2.7pF										
3.0pF										
3.3pF										
3.6pF										
3.9pF										
4.7pF										
5.0pF										
5.6pF										
6.8pF										
8.0pF				1.6±0.3	1.6±0.3					
8.2pF										
10pF										
12pF	1.6±0.3	1.6±0.3	1.6±0.3							
15pF						1.6±0.3	1.6±0.3	1.6±0.3		
18pF										
22pF										
27pF										
33pF										
39pF										
47pF										
56pF										
68pF										
100pF									2.0±0.3	2.0±0.3
120pF										
150pF										
180pF										
220pF				1.6±0.3	2.0±0.3					
270pF										
330pF										
390pF				1.6±0.3						
470pF										
560pF			1.6±0.3	2.0±0.3						
680pF	1.6±0.3	1.6±0.3	1.6±0.3	2.0±0.3						
1nF			2.0±0.3							
1.5nF						1.6±0.3	1.6±0.3	2.0±0.3		
1.8nF	1.6±0.3	1.6±0.3								
2.2nF										
2.7nF										
3.3nF										
3.9nF	1.6±0.3	2.0±0.3								
4.7nF						1.6±0.3	1.6±0.3			
5.6nF	1.6±0.3									
6.8nF										
10nF										
15nF										

备注：1、对应产品设计厚度，单位：mm

2、可根据客户的特殊要求设计符合客户需求的产品



II 类电容器具体电压对应容量及厚度情况列表

AM01 规格(0.6mm*0.3mm)

材料	X7R		X7S			X7T				X5R				
	≤ 25V	50V	≤ 10V	16V	25V	50V	≤ 10V	16V	25V	50V	≤ 10V	16V	25V	50V
120pF														
150pF														
180pF														
220pF														
270pF														
330pF														
390pF														
470pF														
560pF		0.3 ± 0.03 (N)				0.3 ± 0.03 (N)				0.3 ± 0.03 (N)				0.3 ± 0.03 (N)
680pF	0.3 ± 0.03 (N)				0.3 ± 0.03 (N)				0.3 ± 0.03 (N)				0.3 ± 0.03 (N)	
1nF														
1.2nF														
1.5nF														
1.8nF			0.3 ± 0.03 (N)				0.3 ± 0.03 (N)				0.3 ± 0.03 (N)			
2.2nF														
2.7nF														
3.3nF														
3.9nF														
4.7nF														
5.6nF														
6.8nF														
10nF														
12nF														
15nF														
18nF														
22nF														
27nF														
33nF														
39nF														
47nF														
56nF							0.3 ± 0.05 (N)				0.3 ± 0.05 (N)			
68nF														
100nF														

备注：1、对应产品设计厚度，单位：mm；“（N）”表示 N 端头产品，“（A）”表示柔性端头产品

2、可根据客户的特殊要求设计符合客户需求的产品

AM02 规格(1.0mm*0.5mm) _X5R 系列(85℃)

材料	X5R			
	6.3V	10V	16V	25V
56nF				
68nF	0.50±0.05 (A)	0.50±0.05 (A)	0.50±0.05 (A)	0.50±0.05 (A)
100nF				
220nF				0.50±0.05 (N)
330nF	0.50±0.05 (N)	0.50±0.05 (N)	0.50±0.05 (N)	
470nF				
680nF				
1uF	0.50±0.15 (N)	0.50±0.15 (N)		

备注：1、对应产品设计厚度，单位：mm；“（N）”表示 N 端头产品，“（A）”表示柔性端头产品

2、可根据客户的特殊要求设计符合客户需求的产品



AM02 规格(1.0mm*0.5mm) _X7R 系列 (125℃)

材料	X7R					
	6.3V	10V	16V	25V	50V	100V
120pF	0.50±0.05 (A)	0.50±0.05 (A)	0.50±0.05 (A)	0.50±0.05 (A)	0.50±0.05 (A)	0.50±0.05 (A)
150pF						
180pF						
220pF						
270pF						
330pF						
390pF						
470pF						
560pF						
680pF						
1nF						
1.2nF						
1.5nF						
1.8nF						
2.2nF						
2.7nF						
3.3nF						
3.9nF						
4.7nF						
5.6nF						
6.8nF						
10nF	0.50±0.05 (A)	0.50±0.05 (A)	0.50±0.05 (A)	0.50±0.05 (A)	0.50±0.05 (A)	
12nF						
15nF						
18nF						
22nF						
27nF						
33nF						
39nF						
47nF						
56nF						

_X7S/X7T 系列 (125℃)

材料	X7S				X7T	
	6.3V	10V	16V	25V	6.3V	10V
39nF	0.50±0.05 (A)	0.50±0.05 (A)	0.50±0.05 (A)	0.50±0.05 (A)	0.50±0.05 (A)	0.50±0.05 (A)
47nF						
56nF						
68nF						
100nF	0.50±0.05 (N)	0.50±0.05 (N)			0.50±0.05 (N)	0.50±0.05 (N)
220nF						
330nF						
470nF						
680nF					0.50±0.15 (N)	0.50±0.15 (N)
1uF						

备注：1、对应产品设计厚度，单位：mm；“(N)”表示 N 端头产品，“(A)”表示柔性端头产品
2、可根据客户的特殊要求设计符合客户需求的产品



AM03 规格(1.6mm*0.8mm)_X5R 系列 (85℃)

材料	X5R				
电压	6.3V	10V	16V	25V	50V
47nF	0.80±0.10 (A)	0.80±0.10 (A)	0.80±0.10 (A)	0.80±0.10 (A)	0.80±0.10 (A)
100nF	0.80±0.10 (N)	0.80±0.10 (N)	0.80±0.10 (N)	0.80±0.10 (N)	0.80±0.10 (N)
220nF					
330nF					
470nF					
680nF					
1uF	0.80±0.20 (N)	0.80±0.20 (N)			
2.2uF					
3.3uF					
4.7uF					

_X7R 系列 (125℃)

材料	X7R					
电压	6.3V	10V	16V	25V	50V	100V
120pF	0.80±0.10 (A)	0.80±0.10 (A)	0.80±0.10 (A)	0.80±0.10 (A)	0.80±0.10 (A)	0.80±0.10 (A)
150pF						
180pF						
220pF						
270pF						
330pF						
390pF						
470pF						
560pF						
680pF						
1nF						
1.2nF						
1.5nF						
1.8nF						
2.2nF						
2.7nF						
3.3nF						
3.9nF						
4.7nF						
5.6nF						
6.8nF						
10nF						
12nF						
15nF						
18nF						
22nF						
27nF						
33nF						
39nF						
47nF						
56nF						
68nF						
100nF	0.80±0.10 (N)	0.80±0.10 (N)	0.80±0.10 (N)	0.80±0.10 (N)	0.80±0.10 (N)	0.80±0.10 (N)
220nF	0.80±0.10 (N)	0.80±0.10 (N)	0.80±0.10 (N)	0.80±0.10 (N)	0.80±0.10 (N)	



X7S/X7T 系列 (125℃)

材料	X7S					X7T	
	6.3V	10V	16V	25V	50V	6.3V	10V
47nF							
56nF	0.80±0.10 (A)	0.80±0.10 (A)	0.80±0.10 (A)	0.80±0.10 (A)	0.80±0.10 (A)	0.80±0.10 (A)	0.80±0.10 (A)
68nF							
100nF					0.80±0.10 (N)		
220nF	0.80±0.10 (N)	0.80±0.10 (N)	0.80±0.10 (N)	0.80±0.10 (N)			
330nF							
470nF						0.80±0.10 (N)	0.80±0.10 (N)
680nF	0.80±0.10 (N)	0.80±0.10 (N)	0.80±0.10 (N)				
1uF							
2.2uF							

备注：1、对应产品设计厚度，单位：mm；“(N)”表示 N 端头产品，“(A)”表示柔性端头产品
2、可根据客户的特殊要求设计符合客户需求的产品

AM05 规格(2.0mm*1.25mm)_X5R 系列 (85℃)

材料	X5R					
	6.3V	10V	16V	25V	50V	100V
56nF						0.80±0.20 (A)
68nF	0.80±0.20 (A)	0.80±0.20 (A)	0.80±0.20 (A)	0.80±0.20 (A)	0.80±0.20 (A)	
100nF						1.25±0.20 (N)
220nF	0.80±0.20 (N)	0.80±0.20 (N)	0.80±0.20 (N)	0.80±0.20 (N)	0.80±0.20 (N)	
330nF						
470nF						
680nF					1.25±0.20 (N)	
1uF	1.25±0.20 (N)	1.25±0.20 (N)	1.25±0.20 (N)	1.25±0.20 (N)		
2.2uF						
3.3uF						
4.7uF						
6.8uF	1.25±0.20 (N)	1.25±0.20 (N)				
10uF						

X7R 系列 (125℃)

材料	X7R						
	≤10V	16V	25V	50V	100V	250V	500V
120pF							
150pF							
180pF							
220pF							
270pF							
330pF							
390pF	0.80±0.20 (A)	0.80±0.20 (A)	0.80±0.20 (A)	0.80±0.20 (A)	0.80±0.20 (A)	0.80±0.20 (A)	0.80±0.20 (A)
470pF							
560pF							
680pF							
1nF							
1.2nF							
1.5nF							
1.8nF							

接下页



接上页

材料	X7R						
	≤10V	16V	25V	50V	100V	250V	500V
2.2nF	0.80±0.20 (A)	0.80±0.20 (A)	0.80±0.20 (A)	0.80±0.20 (A)	0.80±0.20 (A)	0.80±0.20 (A)	0.80±0.20 (A)
2.7nF							
3.3nF	0.80±0.20 (A)	0.80±0.20 (A)	0.80±0.20 (A)	0.80±0.20 (A)	0.80±0.20 (A)	0.80±0.20 (A)	1.25±0.20 (N)
3.9nF							
4.7nF							
5.6nF	0.80±0.20 (A)	0.80±0.20 (A)	0.80±0.20 (A)	0.80±0.20 (A)	0.80±0.20 (A)	1.25±0.20 (N)	
6.8nF							
10nF							
12nF	0.80±0.20 (A)	0.80±0.20 (A)	0.80±0.20 (A)	0.80±0.20 (A)	0.80±0.20 (A)	1.25±0.20 (N)	
15nF							
18nF							
22nF							
27nF							
33nF	0.80±0.20 (A)	0.80±0.20 (A)	0.80±0.20 (A)	0.80±0.20 (A)	0.80±0.20 (A)		
39nF							
47nF							
56nF	0.80±0.20 (A)	0.80±0.20 (A)	0.80±0.20 (A)	0.80±0.20 (A)	0.80±0.20 (A)		
68nF							
100nF							
220nF	0.80±0.20 (N)	0.80±0.20 (N)	0.80±0.20 (N)	0.80±0.20 (N)	1.25±0.20 (N)		
330nF							
470nF	1.25±0.20 (N)	1.25±0.20 (N)	1.25±0.20 (N)	1.25±0.20 (N)			
680nF							
1uF							

X7S/X7T 系列 (125°C)

材料	X7S			X7T			
	≤10V	16V	25V	6.3V	10V	16V	25V
56nF	0.80±0.20 (A)	0.80±0.20 (A)	0.80±0.20 (A)	0.80±0.20 (A)	0.80±0.20 (A)	0.80±0.20 (A)	0.80±0.20 (A)
68nF							
100nF							
220nF	0.80±0.20 (N)	0.80±0.20 (N)	0.80±0.20 (N)	0.80±0.20 (N)	0.80±0.20 (N)	0.80±0.20 (N)	0.80±0.20 (N)
330nF							
470nF	1.25±0.20 (N)	1.25±0.20 (N)	1.25±0.20 (N)	1.25±0.20 (N)	1.25±0.20 (N)	1.25±0.20 (N)	1.25±0.20 (N)
680nF							
1uF							
2.2uF				1.25±0.20 (N)	1.25±0.20 (N)	1.25±0.20 (N)	
3.3uF							
4.7uF							
6.8uF				1.25±0.20 (N)			
10uF							

备注：1、对应产品设计厚度，单位：mm；“（N）”表示 N 端头产品，“（A）”表示柔性端头产品
2、可根据客户的特殊要求设计符合客户需求的产品



AM06 规格(3.2mm*1.6mm)_X5R 系列 (85℃)

材料	X5R				
电压	6.3V	10V	16V	25V	50V
2.2uF	1.60±0.30 (N)	1.60±0.30 (N)	1.60±0.30 (N)	1.60±0.30 (N)	1.60±0.30 (N)
3.3uF					
4.7uF					
6.8uF	1.60±0.30 (N)	1.60±0.30 (N)	1.60±0.30 (N)	1.60±0.30 (N)	
10uF					
15uF	1.60±0.30 (N)	1.60±0.30 (N)			
22uF					

X7R 系列 (125℃)

材料	X7R						
电压	≤25V	50V	100V	250V	500V	1000V	2000V
120pF	0.80±0.20 (A)	0.80±0.20 (A)	0.80±0.20 (A)	0.80±0.20 (A)	0.80±0.20 (A)	0.80±0.20 (A)	1.25±0.20 (N)
150pF							
180pF							
220pF							
270pF							
330pF							
390pF							
470pF							
560pF							
680pF							
1nF	0.80±0.20 (A)	0.80±0.20 (A)	0.80±0.20 (A)	0.80±0.20 (A)	0.80±0.20 (A)	1.25±0.20 (N)	
1.2nF							
1.5nF							
1.8nF							
2.2nF							
2.7nF							
3.3nF							
3.9nF							
4.7nF							
5.6nF							
6.8nF	0.80±0.20 (A)	0.80±0.20 (A)	0.80±0.20 (A)	1.25±0.20 (N)	1.25±0.20 (N)		
10nF							
12nF							
15nF							
18nF							
22nF							
27nF							
33nF							
39nF							
47nF							
56nF	0.80±0.20 (A)	0.80±0.20 (A)	1.25±0.20 (N)				
68nF							
100nF							
220nF							
330nF							
470nF							
	0.80±0.20 (N)	0.80±0.20 (N)	1.60±0.30 (N)				

接下页



接上页

材料	X7R						
电压	≤25V	50V	100V	250V	500V	1000V	2000V
680nF	0.80±0.20 (N)	0.80±0.20 (N)	1.60±0.30 (N)				
1uF	0.80±0.20 (N)	1.60±0.30 (N)					
2.2uF	1.60±0.30 (N)	1.60±0.30 (N)					
3.3uF							
4.7uF							

X7S/X7T 系列 (125℃)

材料	X7S			X7T			
电压	≤25V	50V	100V	6.3V	10V	16V	25V
1uF	0.80±0.20 (N)	1.60±0.30 (N)	1.60±0.30 (N)	0.80±0.20 (N)	0.80±0.20 (N)	0.80±0.20 (N)	0.80±0.20 (N)
2.2uF	1.60±0.30 (N)	1.60±0.30 (N)		1.60±0.30 (N)	1.60±0.30 (N)	1.60±0.30	1.60±0.30
3.3uF	1.60±0.30 (N)						
4.7uF							
6.8uF				1.60±0.30 (N)	1.60±0.30 (N)		
10uF							
22uF				1.60±0.30 (N)			

备注：1、对应产品设计厚度，单位：mm；“(N)”表示 N 端头产品，“(A)”表示柔性端头产品
2、可根据客户的特殊要求设计符合客户需求的产品

AM10 规格(3.2mm*2.5mm) X7R 系列 (125℃)

材料	X7R					
电压	≤50V	100V	250V	500V	1000V	2000V
120pF	1.25±0.20 (N)	1.25±0.20 (N)	1.25±0.20 (N)	1.25±0.20 (N)	1.25±0.20 (N)	
150pF						
180pF						
220pF						
270pF						
330pF						
390pF						
470pF						
560pF	1.25±0.20 (N)	1.25±0.20 (N)	1.25±0.20 (N)	1.25±0.20 (N)	1.25±0.20 (N)	1.25±0.20 (N)
680pF						
1nF						
1.2nF						
1.5nF						
1.8nF						
2.2nF						
3.3nF						
4.7nF						

接下页



接上页

材料	X7R					
电压	≤50V	100V	250V	500V	1000V	2000V
5.6nF	1.25±0.20 (N)	1.25±0.20 (N)	1.25±0.20 (N)	1.25±0.20 (N)	1.25±0.20 (N)	1.60±0.30 (N)
6.8nF	1.25±0.20 (N)	1.25±0.20 (N)	1.25±0.20 (N)	1.25±0.20 (N)	1.60±0.30 (N)	
10nF	1.25±0.20 (N)	1.25±0.20 (N)	1.25±0.20 (N)	1.25±0.20 (N)	1.60±0.30 (N)	
12nF	1.25±0.20 (N)	1.25±0.20 (N)	1.25±0.20 (N)	1.25±0.20 (N)	1.60±0.30 (N)	
15nF						
18nF						
22nF						
27nF	1.25±0.20 (N)	1.25±0.20 (N)	1.25±0.20 (N)	1.60±0.30 (N)		
33nF						
39nF						
47nF						
56nF						
68nF						
100nF						
220nF	1.60±0.30 (N)	1.60±0.30 (N)	1.60±0.30 (N)			
330nF	1.60±0.30 (N)	1.60±0.30 (N)				
470nF						
680nF						
1uF						
2.2uF	1.60±0.30 (N)					
3.3uF						
4.7uF						

备注：1、对应产品设计厚度，单位：mm；“(N)”表示N端头产品，“(A)”表示柔性端头产品
2、可根据客户的特殊要求设计符合客户需求的产品

AM08 规格(4.5mm*2.0mm) _X7R 系列 (125℃)

材料	X7R				
电压	≤250V	500V	1000V	2000V	3000V
120pF	1.60±0.30 (N)	1.60±0.30 (N)	1.60±0.30 (N)	1.60±0.30 (N)	1.60±0.30 (N)
150pF					
180pF					
220pF					
270pF					
330pF					
390pF					
470pF					
560pF					
680pF					
1nF					
1.2nF					
1.5nF					
1.8nF					
2.2nF					

接下页



接上页

材料	X7R				
	≤250V	500V	1000V	2000V	3000V
2.7nF	1.60±0.30 (N)	1.60±0.30 (N)	1.60±0.30 (N)	1.60±0.30 (N)	1.60±0.30 (N)
3.3nF					
3.9nF					
4.7nF					
5.6nF	1.60±0.30 (N)	1.60±0.30 (N)	1.60±0.30 (N)	1.60±0.30 (N)	
6.8nF					
10nF					
12nF					
15nF	1.60±0.30 (N)	1.60±0.30 (N)	1.60±0.30 (N)		
18nF					
22nF					
27nF					
33nF	1.60±0.30 (N)	1.60±0.30 (N)	2.00±0.30 (N)		
39nF	1.60±0.30 (N)	1.60±0.30 (N)			
47nF					
56nF	1.60±0.30 (N)	2.50±0.30 (N)			
68nF					
100nF	1.60±0.30 (N)				
220nF	2.00±0.30 (N)				
330nF					
470nF					
680nF					

备注：1、对应产品设计厚度，单位：mm；“(N)”表示N端头产品，“(A)”表示柔性端头产品
2、可根据客户的特殊要求设计符合客户需求的产品

AM12 规格(4.5mm*3.2mm) _X7R 系列 (125℃)

材料	X7R				
	≤250V	500V	1000V	2000V	3000V
120pF	1.60±0.30 (N)	1.60±0.30 (N)	1.60±0.30 (N)	1.60±0.30 (N)	1.60±0.30 (N)
150pF					
180pF					
220pF					
270pF					
330pF					
390pF					
470pF					
560pF					
680pF					
1nF					
1.2nF					
1.5nF					
1.8nF					
2.2nF					

接下页



接上页

材料	X7R				
	≤250V	500V	1000V	2000V	3000V
2.7nF	1.60±0.30 (N)	1.60±0.30 (N)	1.60±0.30 (N)	1.60±0.30 (N)	1.60±0.30 (N)
3.3nF					
3.9nF					
4.7nF					
5.6nF	1.60±0.30 (N)	1.60±0.30 (N)	1.60±0.30 (N)	1.60±0.30 (N)	
6.8nF					
10nF					
12nF					
15nF	1.60±0.30 (N)	1.60±0.30 (N)	1.60±0.30 (N)		
18nF					
22nF					
27nF					
33nF					
39nF					
47nF	1.60±0.30 (N)	1.60±0.30 (N)	2.00±0.30 (N)		
56nF					
68nF					
100nF					
220nF	1.60±0.30 (N)				
330nF					
470nF					
680nF					
1 μF	2.00±0.30 (N)				

备注：1、对应产品设计厚度，单位：mm；“N”表示N端头产品，“A”表示柔性端头产品
2、可根据客户的特殊要求设计符合客户需求的产品

AM20 规格(5.7mm*5.0mm) _X7R 系列 (125℃)

材料	X7R				
	250V	500V	1000V	2000V	3000V
1nF	1.60±0.30 (N)	1.60±0.30 (N)	1.60±0.30 (N)	1.60±0.30 (N)	1.60±0.30 (N)
1.2nF					
1.5nF					
1.8nF					
2.2nF					
2.7nF					
3.3nF					
3.9nF					
4.7nF					
5.6nF					
6.8nF	1.60±0.30 (N)	1.60±0.30 (N)	1.60±0.30 (N)	1.60±0.30 (N)	
10nF					
12nF					
15nF	1.60±0.30 (N)	1.60±0.30 (N)	1.60±0.30 (N)	1.60±0.30 (N)	

接下页



接上页

材料	X7R				
	250V	500V	1000V	2000V	3000V
18nF	1.60±0.30 (N)	1.60±0.30 (N)	1.60±0.30 (N)	1.60±0.30 (N)	
22nF					
27nF					
33nF	1.60±0.30 (N)	1.60±0.30 (N)	1.60±0.30 (N)	1.80±0.30 (N)	
39nF					
47nF	1.60±0.30 (N)	1.60±0.30 (N)	1.60±0.30 (N)	2.00±0.30 (N)	
56nF					
68nF	1.60±0.30 (N)	1.60±0.30 (N)	1.60±0.30 (N)		
100nF	1.60±0.30 (N)	1.60±0.30 (N)	2.00±0.30 (N)		
220nF					
330nF	1.60±0.30 (N)	1.60±0.30 (N)			
470nF	1.60±0.30 (N)	2.00±0.30 (N)			
680nF					
1 μ F	2.00±0.30 (N)				

备注：1、对应产品设计厚度，单位：mm；“(N)”表示N端头产品，“(A)”表示柔性端头产品
2、可根据客户的特殊要求设计符合客户需求的产品

六、可靠性测试

序号	项目	技术规格	测试方法			
			标称容量	测试频率	测试电压	
1	容量	I类	应符合指定的误差级别	≤1000pF	1MHz±10%	1.0±0.2Vrms
				>1000 pF	1KHz±10%	
		II类	应符合指定的误差级别	测试温度：25℃±3℃ C≤10μF：测试频率：1KHz±10% 测试电压：1.0±0.2Vrms C>10μF：测试频率：120±24 Hz 测试电压：0.5±0.1Vrms		
2	绝缘电阻 (IR)	I类	C≤10 nF, Ri≥100000M Ω C>10 nF, Ri·Cr≥1000S	测试电压：额定电压 测试时间：60±5 秒 测试湿度：≤75% 测试温度：25℃±3℃ 测试充放电电流：≤50mA		
		II类	C≤25 nF, Ri≥10000M Ω C>25 nF, Ri·Cr≥100S			
3	I类损耗 (DF)	DF	标称容量	测试频率：1MHz±10% 测试电压：1.0±0.2Vrms		
		≤0.1%	Cr≥30pF			
		≤0.15%	Cr<30 pF			



序号	项目	技术规格						测试方法				
3	II 类 损耗 (DF)	电压	DF	0201	0402	0603	0805	1206 及 以上	C ≤ 10μF 测试频率： 1KHz ± 10% 测试电压： 1.0 ± 0.2Vrms C > 10μF 测试频率： 120 ± 24 Hz 测试电压： 0.5 ± 0.1Vrms			
		≥ 100V	DF ≅ 5%	—	≤10nF	≤100nF	≤330nF	≤680nF				
		50V	DF ≅ 2.5%	≤3.3nF	≤10nF	≤100nF	≤330nF	≤680nF				
			DF ≅ 3.5%	≤10nF	—	—	—	≤1μF				
			DF ≅ 5%	—	—	—	≤680nF	—				
			DF ≅ 10%	—	≤1μF	≤2.2μF	≤4.7μF	≤10μF				
		25V	DF ≅ 2.5%	≤3.3nF	≤10nF	≤150nF	≤330nF	≤680nF				
			DF ≅ 3.5%	≤10nF	≤100nF	≤330nF	—	≤2.2μF				
			DF ≅ 5%	—	—	—	≤1μF	—				
			DF ≅ 7.5%	—	—	—	≤2.2μF	≤4.7μF				
		16V	DF ≅ 2.5%	≤3.3nF	≤10nF	≤150nF	≤330nF	≤680nF				
			DF ≅ 3.5%	≤15nF	≤100nF	≤330nF	—	≤2.2μF				
			DF ≅ 5%	≤47nF	≤220nF	≤680nF	≤2.2μF	—				
			DF ≅ 7.5%	—	—	—	≤4.7μF	≤4.7μF				
		10V	DF ≅ 2.5%	≤3.3nF	≤10nF	≤150nF	≤330nF	≤680nF				
			DF ≅ 3.5%	≤15nF	≤100nF	≤330nF	—	≤2.2μF				
			DF ≅ 5%	≤47nF	—	≤680nF	≤2.2μF	—				
			DF ≅ 7.5%	—	≤1μF	≤2.2μF	≤4.7μF	≤10μF				
		≅ 6.3V	DF ≅ 2.5%	≤3.3nF	—	≤150nF	—	≤680nF				
			DF ≅ 3.5%	≤15nF	≤100nF	≤330nF	—	≤2.2μF				
			DF ≅ 5%	≤47nF	≤220nF	≤680nF	—	—				
			DF ≅ 7.5%	—	≤1μF	—	10μF~22μF	≤10μF				
				DF ≅ 10%	≤4.7μF	≤22μF	≤47μF	≤100μF				
		4	介质 耐电 强度	不应有介 质被击穿 或损伤	Ur < 100V	测量电压： C0G: 300%额定电压 X7R/X7S: 250%额定电压 时间: 1~5 秒 充/放电电流: 不应超过 50mA						
					100 ≤ Ur < 500V	施加额定电压的 200%, 5 秒, 最大电流不超过 50mA						
					500V ≤ Ur ≤ 1000V	施加额定电压的 150%, 5 秒, 最大电流不超过 50mA						
					1000V < Ur ≤ 2000V	施加额定电压的 120%, 5 秒, 最大电流不超过 50mA						
					Ur > 2000V	施加额定电压的 120%, 5 秒, 最大电流不超过 10mA						





序号	项目	技术规格	测试方法																														
5	外观	无可见损伤	目视检查																														
6	尺寸	在规定尺寸范围内	使用卡尺																														
7	破坏性物理分析 (DPA)	无缺陷或异常	按照 EIA-469																														
8	高温存储	<table border="1"> <thead> <tr> <th>项目</th> <th>I 类</th> <th>II 类</th> </tr> </thead> <tbody> <tr> <td>$\Delta C/C$</td> <td>$\leq \pm 1\%$或$\pm 1pF$, 取两者中最大者</td> <td>$-12.5\% \sim +12.5\%$</td> </tr> <tr> <td>DF</td> <td colspan="2">同初始标准</td> </tr> <tr> <td>IR</td> <td colspan="2">同初始标准</td> </tr> </tbody> </table>	项目	I 类	II 类	$\Delta C/C$	$\leq \pm 1\%$ 或 $\pm 1pF$, 取两者中最大者	$-12.5\% \sim +12.5\%$	DF	同初始标准		IR	同初始标准		温度: 最高工作温度 $125 \pm 2^\circ C$ 实验电压: 不施加电压 实验时间: 1000 小时 放置条件: 室温 放置时间: 24 小时(I 类); 48 小时(II 类)																		
项目	I 类	II 类																															
$\Delta C/C$	$\leq \pm 1\%$ 或 $\pm 1pF$, 取两者中最大者	$-12.5\% \sim +12.5\%$																															
DF	同初始标准																																
IR	同初始标准																																
9	温度冲击	<table border="1"> <thead> <tr> <th>项目</th> <th>I 类</th> <th>II 类</th> </tr> </thead> <tbody> <tr> <td>$\Delta C/C$</td> <td>$\leq \pm 1\%$或$\pm 1pF$, 取两者中最大者</td> <td>$-10\% \sim +10\%$</td> </tr> <tr> <td>DF</td> <td colspan="2">同初始标准</td> </tr> <tr> <td>IR</td> <td colspan="2">同初始标准</td> </tr> <tr> <td colspan="3">外观: 无可见损伤</td> </tr> </tbody> </table>	项目	I 类	II 类	$\Delta C/C$	$\leq \pm 1\%$ 或 $\pm 1pF$, 取两者中最大者	$-10\% \sim +10\%$	DF	同初始标准		IR	同初始标准		外观: 无可见损伤			※预处理* (仅针对 2 类电容器): 上限类别温度, 1 小时; 恢复: $24 \pm 1h$ 初始测量 循环次数: 1000 次 实验方法: 1、样品上板后放置入温冲箱内 2、温度区间为 $-55^\circ C \sim$ 上限温度, 每个温度点停留时间 15min, 温区间转换时间 $<10s$ 试验后放置(恢复)时间: $24 \pm 2h$															
项目	I 类	II 类																															
$\Delta C/C$	$\leq \pm 1\%$ 或 $\pm 1pF$, 取两者中最大者	$-10\% \sim +10\%$																															
DF	同初始标准																																
IR	同初始标准																																
外观: 无可见损伤																																	
10	温度循环	<table border="1"> <thead> <tr> <th>项目</th> <th>I 类</th> <th>II 类</th> </tr> </thead> <tbody> <tr> <td>$\Delta C/C$</td> <td>$\leq \pm 1\%$或$\pm 1pF$,取两者中最大者</td> <td>$-10\% \sim +10\%$</td> </tr> <tr> <td>DF</td> <td colspan="2">同初始标准</td> </tr> <tr> <td>IR</td> <td colspan="2">同初始标准</td> </tr> <tr> <td colspan="3">外观: 无可见损伤</td> </tr> </tbody> </table>	项目	I 类	II 类	$\Delta C/C$	$\leq \pm 1\%$ 或 $\pm 1pF$,取两者中最大者	$-10\% \sim +10\%$	DF	同初始标准		IR	同初始标准		外观: 无可见损伤			※预处理* (仅针对 2 类电容器): 上限类别温度, 1 小时; 恢复: $24 \pm 1h$ 初始测量 循环次数: 1000 次,一个循环分以下 4 步: <table border="1"> <thead> <tr> <th>阶段</th> <th>温度 ($^\circ C$)</th> <th>时间(分钟)</th> </tr> </thead> <tbody> <tr> <td>第 1 步</td> <td>下限温度(-55)</td> <td>30</td> </tr> <tr> <td>第 2 步</td> <td>常温 (+20)</td> <td>1</td> </tr> <tr> <td>第 3 步</td> <td>上限温度 (C0G/X7R/X7S/X7T: +125 X5R:+85)</td> <td>30</td> </tr> <tr> <td>第 4 步</td> <td>常温 (+20)</td> <td>1</td> </tr> </tbody> </table> 试验后放置(恢复)时间: $24 \pm 2h$	阶段	温度 ($^\circ C$)	时间(分钟)	第 1 步	下限温度(-55)	30	第 2 步	常温 (+20)	1	第 3 步	上限温度 (C0G/X7R/X7S/X7T: +125 X5R:+85)	30	第 4 步	常温 (+20)	1
项目	I 类	II 类																															
$\Delta C/C$	$\leq \pm 1\%$ 或 $\pm 1pF$,取两者中最大者	$-10\% \sim +10\%$																															
DF	同初始标准																																
IR	同初始标准																																
外观: 无可见损伤																																	
阶段	温度 ($^\circ C$)	时间(分钟)																															
第 1 步	下限温度(-55)	30																															
第 2 步	常温 (+20)	1																															
第 3 步	上限温度 (C0G/X7R/X7S/X7T: +125 X5R:+85)	30																															
第 4 步	常温 (+20)	1																															



序号	项目	技术规格	测试方法															
11	寿命试验	<table border="1"> <tr> <td>Δ C/C</td> <td colspan="2">I类: $\leq \pm 2.5\%$或$\pm 2.5\text{pF}$ 取两者之中较大者 II类: $\leq \pm 12.5\%$</td> </tr> <tr> <td>DF</td> <td colspan="2">同初始标准</td> </tr> <tr> <td rowspan="2">IR</td> <td colspan="2">I类: $R_i \geq 5000\text{M}\Omega$或$R_i \cdot C_R \geq 50\text{S}$取两者之中较小者.</td> </tr> <tr> <td colspan="2">II类: $R_i \geq 1000\text{M}\Omega$或$R_i \cdot C_R \geq 10\text{S}$取两者之中较小者.</td> </tr> <tr> <td colspan="3">外观: 无损伤</td> </tr> </table>	Δ C/C	I类: $\leq \pm 2.5\%$ 或 $\pm 2.5\text{pF}$ 取两者之中较大者 II类: $\leq \pm 12.5\%$		DF	同初始标准		IR	I类: $R_i \geq 5000\text{M}\Omega$ 或 $R_i \cdot C_R \geq 50\text{S}$ 取两者之中较小者.		II类: $R_i \geq 1000\text{M}\Omega$ 或 $R_i \cdot C_R \geq 10\text{S}$ 取两者之中较小者.		外观: 无损伤			电压: $U_r < 500\text{V}$: 2倍额定电压 $500\text{V} \leq U_r \leq 630\text{V}$: 1.5倍额定电压 $U_r > 630\text{V}$: 1倍额定电压 时间: 1000小时 温度: 125°C 充电电流: 不应超过 50mA 放置条件: 室温 放置时间: 24小时 (I类), 或 48小时 (II类)。	
Δ C/C	I类: $\leq \pm 2.5\%$ 或 $\pm 2.5\text{pF}$ 取两者之中较大者 II类: $\leq \pm 12.5\%$																	
DF	同初始标准																	
IR	I类: $R_i \geq 5000\text{M}\Omega$ 或 $R_i \cdot C_R \geq 50\text{S}$ 取两者之中较小者.																	
	II类: $R_i \geq 1000\text{M}\Omega$ 或 $R_i \cdot C_R \geq 10\text{S}$ 取两者之中较小者.																	
外观: 无损伤																		
12	偏高湿度	<table border="1"> <tr> <td>项目</td> <td>I类</td> <td>II类</td> </tr> <tr> <td>ΔC/C</td> <td>$\leq \pm 2.5\%$或$\pm 2.5\text{pF}$, 取两者之中较大者。</td> <td>$-12.5\% \sim +12.5\%$</td> </tr> <tr> <td>DF</td> <td colspan="2">同初始标准</td> </tr> <tr> <td>IR</td> <td colspan="2">同初始标准</td> </tr> <tr> <td>外观</td> <td colspan="2">无可见损伤</td> </tr> </table>	项目	I类	II类	Δ C/C	$\leq \pm 2.5\%$ 或 $\pm 2.5\text{pF}$, 取两者之中较大者。	$-12.5\% \sim +12.5\%$	DF	同初始标准		IR	同初始标准		外观	无可见损伤		※预处理 (仅针对 2 类电容器): 在 $140^\circ\text{C} \sim 150^\circ\text{C}$ 下预热 1 小时后, 在室温下放置 24 小时。 试验条件: $85 \pm 2^\circ\text{C}$, 80~85%R.H. 串联一个 $100\text{K}\Omega$, 施加额定电压, 1000 小时
项目	I类	II类																
Δ C/C	$\leq \pm 2.5\%$ 或 $\pm 2.5\text{pF}$, 取两者之中较大者。	$-12.5\% \sim +12.5\%$																
DF	同初始标准																	
IR	同初始标准																	
外观	无可见损伤																	
13	可焊性	上锡率应大于 95% 外观: 无可见损伤.	将电容在 $80 \sim 120^\circ\text{C}$ 的温度下预热 10~30 秒. <table border="1"> <tr> <td>有铅焊料: (Sn/Pb: 63/37)</td> <td>无铅焊料:</td> </tr> <tr> <td>浸锡温度: $235 \pm 5^\circ\text{C}$</td> <td>浸锡温度: $245 \pm 5^\circ\text{C}$</td> </tr> <tr> <td>浸锡时间: $2 \pm 0.5\text{s}$</td> <td>浸锡时间: $3 \pm 0.3\text{s}$</td> </tr> </table>	有铅焊料: (Sn/Pb: 63/37)	无铅焊料:	浸锡温度: $235 \pm 5^\circ\text{C}$	浸锡温度: $245 \pm 5^\circ\text{C}$	浸锡时间: $2 \pm 0.5\text{s}$	浸锡时间: $3 \pm 0.3\text{s}$									
有铅焊料: (Sn/Pb: 63/37)	无铅焊料:																	
浸锡温度: $235 \pm 5^\circ\text{C}$	浸锡温度: $245 \pm 5^\circ\text{C}$																	
浸锡时间: $2 \pm 0.5\text{s}$	浸锡时间: $3 \pm 0.3\text{s}$																	
14	耐焊接热	<table border="1"> <tr> <td>项目</td> <td>I类</td> <td>II类</td> </tr> <tr> <td>ΔC/C</td> <td>$\leq \pm 1\%$或$\pm 1\text{pF}$,取 两者之中较大者。</td> <td>$-15\% \sim +15\%$</td> </tr> <tr> <td>DF</td> <td colspan="2">同初始标准</td> </tr> <tr> <td>IR</td> <td colspan="2">同初始标准</td> </tr> <tr> <td>外观</td> <td colspan="2">无可见损伤 上锡率: $\geq 95\%$</td> </tr> </table>	项目	I类	II类	Δ C/C	$\leq \pm 1\%$ 或 $\pm 1\text{pF}$,取 两者之中较大者。	$-15\% \sim +15\%$	DF	同初始标准		IR	同初始标准		外观	无可见损伤 上锡率: $\geq 95\%$		将电容在 $100 \sim 200^\circ\text{C}$ 的温度下预热 60~120 秒. 浸锡温度: $265 \pm 5^\circ\text{C}$ 浸锡时间: $10 \pm 1\text{s}$ 然后取出溶剂清洗干净, 在 10 倍以上的显微镜底下观察 放置时间: 24 ± 2 小时 放置条件: 室温
项目	I类	II类																
Δ C/C	$\leq \pm 1\%$ 或 $\pm 1\text{pF}$,取 两者之中较大者。	$-15\% \sim +15\%$																
DF	同初始标准																	
IR	同初始标准																	
外观	无可见损伤 上锡率: $\geq 95\%$																	
15	静电放电 ESD	<table border="1"> <tr> <td>项目</td> <td>I类</td> <td>II类</td> </tr> <tr> <td>C</td> <td colspan="2">同初始标准</td> </tr> <tr> <td>DF</td> <td colspan="2">同初始标准</td> </tr> <tr> <td>IR</td> <td colspan="2">同初始标准</td> </tr> <tr> <td>外观</td> <td colspan="2">无可见损伤</td> </tr> </table>	项目	I类	II类	C	同初始标准		DF	同初始标准		IR	同初始标准		外观	无可见损伤		参照 AEC-Q200-002 方法进行 ESD 静电放电试验; 放电电压: $2\text{kV} \sim 22\text{kV}$ 按 2kV 步进测试。 每个样品每个电极承受两次放电, 正、负级性各 1 次; 样品经过指定等级的电压后符合验收标准要求, 则使用原样品进入下一个电压应力等级试验。
项目	I类	II类																
C	同初始标准																	
DF	同初始标准																	
IR	同初始标准																	
外观	无可见损伤																	

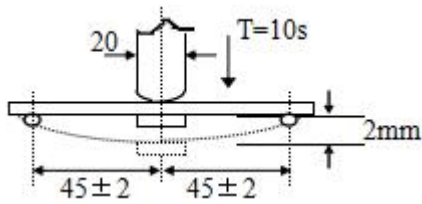

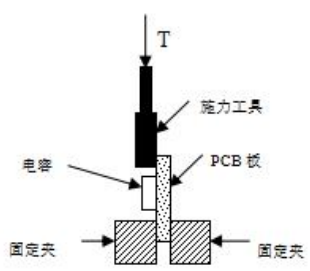
序号	项目	技术规格	测试方法																							
16	抗弯曲度	<table border="1"> <thead> <tr> <th>项目</th> <th>I类</th> <th>II类</th> </tr> </thead> <tbody> <tr> <td>ΔCC</td> <td>$\leq \pm 1\%$或$\pm 1pF$,取两者之中较大者。</td> <td>$-10\% \sim +10\%$</td> </tr> <tr> <td>DF</td> <td colspan="2">同初始标准</td> </tr> <tr> <td>IR</td> <td colspan="2">同初始标准</td> </tr> <tr> <td colspan="3">外观: 无损伤.</td> </tr> </tbody> </table>	项目	I类	II类	ΔCC	$\leq \pm 1\%$ 或 $\pm 1pF$,取两者之中较大者。	$-10\% \sim +10\%$	DF	同初始标准		IR	同初始标准		外观: 无损伤.			试验基板: Al_2O_3 或 PCB 弯曲深度: 2mm 施压速度: 1mm/sec.; 单位: mm 应在弯曲状态下进行测量。 								
项目	I类	II类																								
ΔCC	$\leq \pm 1\%$ 或 $\pm 1pF$,取两者之中较大者。	$-10\% \sim +10\%$																								
DF	同初始标准																									
IR	同初始标准																									
外观: 无损伤.																										
17	射束负载 (断裂强度)	<table border="1"> <thead> <tr> <th>规格</th> <th>产品厚度</th> <th>最小受力</th> </tr> </thead> <tbody> <tr> <td rowspan="2">$\leq AU05$</td> <td>$> 0.5mm$</td> <td>20N</td> </tr> <tr> <td>$\leq 0.5mm$</td> <td>8N</td> </tr> <tr> <td rowspan="2">$\geq AU06$</td> <td>$\geq 1.25mm$</td> <td>54N</td> </tr> <tr> <td>$< 1.25mm$</td> <td>15N</td> </tr> </tbody> </table>	规格	产品厚度	最小受力	$\leq AU05$	$> 0.5mm$	20N	$\leq 0.5mm$	8N	$\geq AU06$	$\geq 1.25mm$	54N	$< 1.25mm$	15N	如图所示 产品在测试过程中瓷体断裂时所受力必须大于最小受力。 										
规格	产品厚度	最小受力																								
$\leq AU05$	$> 0.5mm$	20N																								
	$\leq 0.5mm$	8N																								
$\geq AU06$	$\geq 1.25mm$	54N																								
	$< 1.25mm$	15N																								
18	端子强度 (SMD)	<table border="1"> <thead> <tr> <th>项目</th> <th>I类</th> <th>II类</th> </tr> </thead> <tbody> <tr> <td>ΔCC</td> <td>$\leq \pm 0.5\%$</td> <td>$-10\% \sim +10\%$</td> </tr> <tr> <td>DF</td> <td colspan="2">同初始标准</td> </tr> <tr> <td>IR</td> <td colspan="2">同初始标准</td> </tr> <tr> <td>外观</td> <td colspan="2">无可见损伤</td> </tr> </tbody> </table>	项目	I类	II类	ΔCC	$\leq \pm 0.5\%$	$-10\% \sim +10\%$	DF	同初始标准		IR	同初始标准		外观	无可见损伤		如图所示 慢慢施加一个 T 的力到电容侧面瓷体上, 并保持 60+1 秒。  <table border="1"> <thead> <tr> <th>规格</th> <th>施加力 T</th> </tr> </thead> <tbody> <tr> <td>AU02</td> <td>2N</td> </tr> <tr> <td>AU03</td> <td>10N</td> </tr> <tr> <td>$> AU03$</td> <td>17.7N</td> </tr> </tbody> </table>	规格	施加力 T	AU02	2N	AU03	10N	$> AU03$	17.7N
项目	I类	II类																								
ΔCC	$\leq \pm 0.5\%$	$-10\% \sim +10\%$																								
DF	同初始标准																									
IR	同初始标准																									
外观	无可见损伤																									
规格	施加力 T																									
AU02	2N																									
AU03	10N																									
$> AU03$	17.7N																									
19	温度特性	<table border="1"> <thead> <tr> <th>项目</th> <th>ΔCC</th> </tr> </thead> <tbody> <tr> <td>C0G</td> <td>$\pm 0.2\%$或$\pm 0.05pF$</td> </tr> <tr> <td>X7R</td> <td>$\pm 15\%$</td> </tr> <tr> <td>X7S</td> <td>$\pm 22\%$</td> </tr> <tr> <td>X7T</td> <td>$-33\% \sim +22\%$</td> </tr> </tbody> </table>	项目	ΔCC	C0G	$\pm 0.2\%$ 或 $\pm 0.05pF$	X7R	$\pm 15\%$	X7S	$\pm 22\%$	X7T	$-33\% \sim +22\%$	在 $-55^\circ C$ 、 $20^\circ C$ 、 $125^\circ C$ 三个温度点分别测量产品电性能													
项目	ΔCC																									
C0G	$\pm 0.2\%$ 或 $\pm 0.05pF$																									
X7R	$\pm 15\%$																									
X7S	$\pm 22\%$																									
X7T	$-33\% \sim +22\%$																									



序号	项目	技术规格	测试方法															
20	振动	<table border="1"> <thead> <tr> <th>项目</th> <th>I 类</th> <th>II 类</th> </tr> </thead> <tbody> <tr> <td>$\Delta C/C$</td> <td>$\leq \pm 1\%$或$\pm 1pF$, 取两者中最大者</td> <td>-10%~$+10\%$</td> </tr> <tr> <td>DF</td> <td colspan="2">同初始标准</td> </tr> <tr> <td>IR</td> <td colspan="2">同初始标准</td> </tr> <tr> <td>外观</td> <td colspan="2">无可见损伤</td> </tr> </tbody> </table>	项目	I 类	II 类	$\Delta C/C$	$\leq \pm 1\%$ 或 $\pm 1pF$, 取两者中最大者	-10% ~ $+10\%$	DF	同初始标准		IR	同初始标准		外观	无可见损伤		5g 的力 20 分钟，三个方向每个方向 12 个循环。 注意：使用 8"X5" 印刷线路板，.031"厚，在长的一边有 7 个固定点，在对面的边的角有 2 个固定点。产品在距离固定点 2" 内安装。 测试频率从 10-2000 赫兹。
		项目	I 类	II 类														
		$\Delta C/C$	$\leq \pm 1\%$ 或 $\pm 1pF$, 取两者中最大者	-10% ~ $+10\%$														
		DF	同初始标准															
		IR	同初始标准															
外观	无可见损伤																	
21	机械冲击	<table border="1"> <thead> <tr> <th>项目</th> <th>I 类</th> <th>II 类</th> </tr> </thead> <tbody> <tr> <td>$\Delta C/C$</td> <td>$\leq \pm 1\%$或$\pm 1pF$, 取两者中最大者</td> <td>-10%~$+10\%$</td> </tr> <tr> <td>DF</td> <td colspan="2">同初始标准</td> </tr> <tr> <td>IR</td> <td colspan="2">同初始标准</td> </tr> <tr> <td>外观</td> <td colspan="2">无可见损伤</td> </tr> </tbody> </table>	项目	I 类	II 类	$\Delta C/C$	$\leq \pm 1\%$ 或 $\pm 1pF$, 取两者中最大者	-10% ~ $+10\%$	DF	同初始标准		IR	同初始标准		外观	无可见损伤		应沿试件的 3 个互相垂直轴，在每个方向上实施 3 次冲击试验 (共计 18 次冲击)。 脉冲波形：正弦半波 持续时长：0.5 毫秒 峰值：1500g 速度变化：4.7m/s
		项目	I 类	II 类														
		$\Delta C/C$	$\leq \pm 1\%$ 或 $\pm 1pF$, 取两者中最大者	-10% ~ $+10\%$														
		DF	同初始标准															
		IR	同初始标准															
外观	无可见损伤																	

七、包装

● 纸带卷盘结构

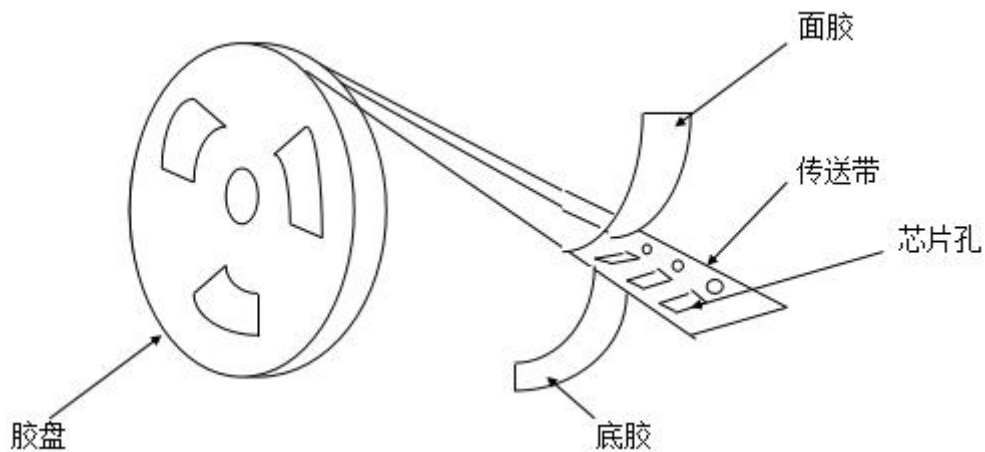



※ AM01、AM02 纸带编带尺寸大小

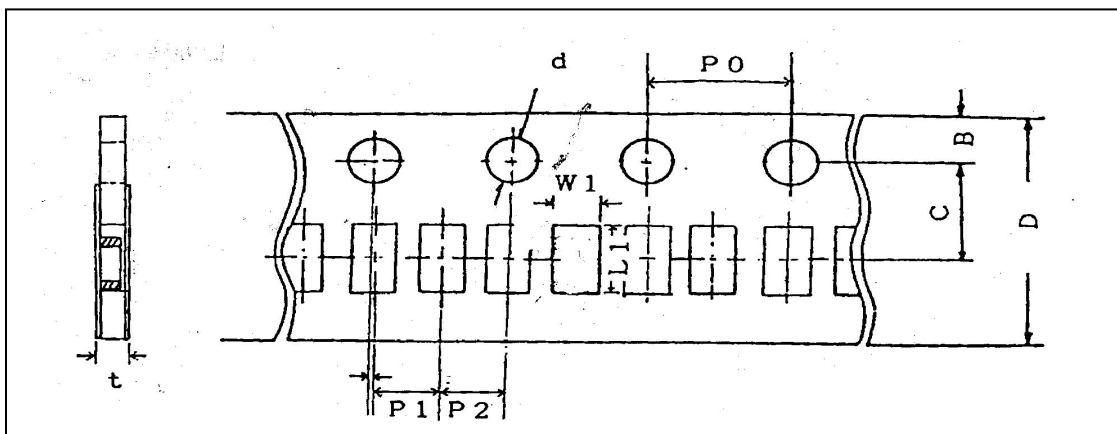

Unit: mm

代号 纸带规格	W1	L1	D	C	B	P1	P2	P0	d	t
AM01	0.37± 0.10	0.67±0 .10	8.00± 0.10	3.50± 0.05	1.75± 0.10	2.00± 0.05	2.00± 0.05	4.00± 0.10	1.50 -0/+0.10	0.80 Below
AM02	0.65± 0.10	1.15± 0.10	8.00± 0.10	3.50± 0.05	1.75± 0.10	2.00± 0.05	2.00± 0.05	4.00± 0.10	1.50 -0/+0.10	0.80 Below

※ 适合‘AM03, AM05, AM06’常规尺寸产品的纸带尺寸

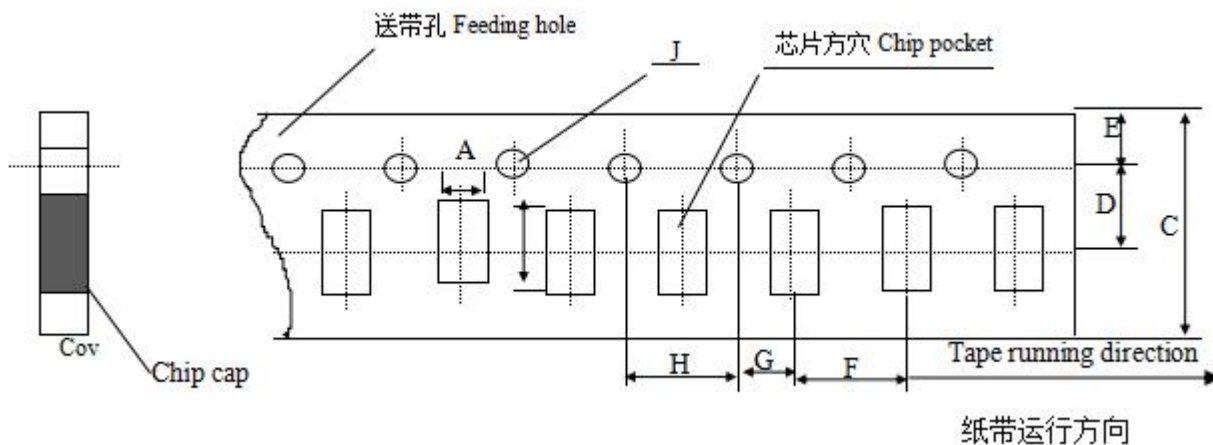

Unit: mm

代号 纸带规格	A	B	C	D*	E	F	G*	H	J	T
AM03	1.10 ±0.10	1.90 ±0.10	8.00 ±0.10	3.50 ±0.05	1.75 ±0.10	4.00 ±0.10	2.00 ±0.10	4.00 ±0.10	1.50 -0/+0.10	1.10 Max
AM05	1.45 ±0.15	2.30 ±0.15	8.0 ±0.15	3.50 ±0.05	1.75 ±0.10	4.00 ±0.10	2.00 ±0.10	4.00 ±0.10	1.50 -0/+0.10	1.10 Max
AM06	1.80 ±0.20	3.40 ±0.20	8.00 ±0.20	3.50 ±0.05	1.75 ±0.10	4.00 ±0.10	2.00 ±0.10	4.00 ±0.10	1.50 -0/+0.10	1.10 Max

注意：*表示此处对尺寸的要求非常精确。



● 塑胶卷盘结构

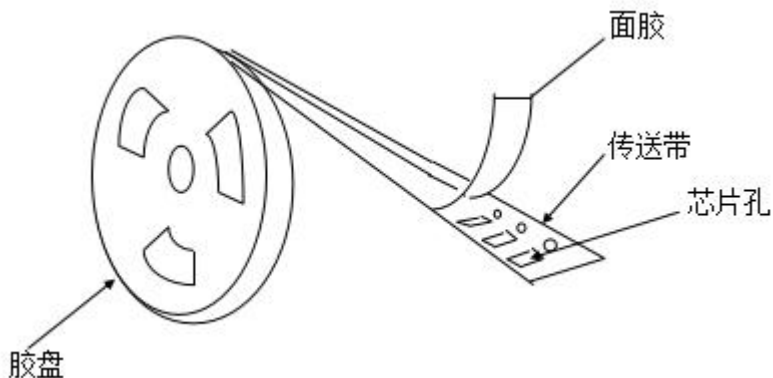

※ 塑胶带尺寸结构(适合 ‘AM05、AM06、AM10、AM08、AM12、AM20’ 型产品)

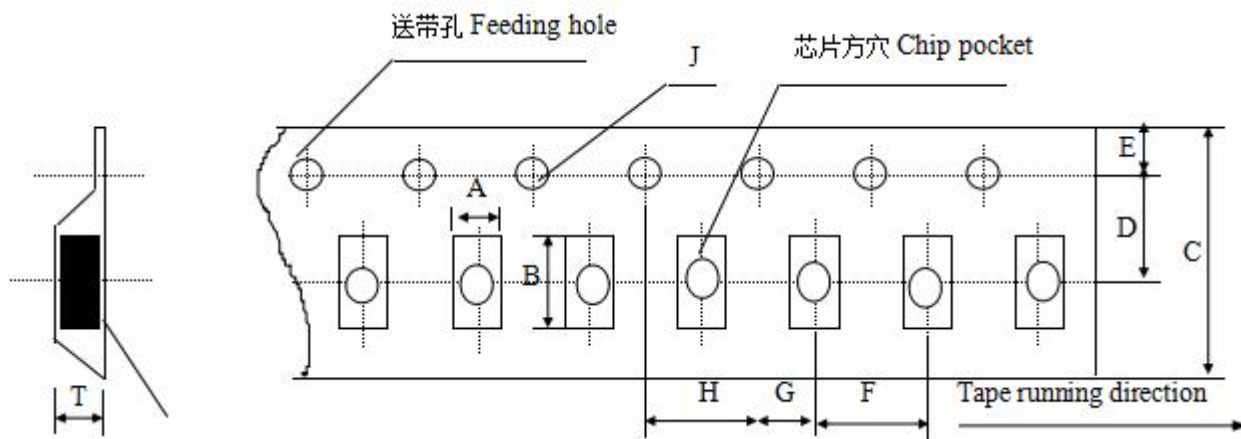

Unit: mm

代号 规格	A	B	C	D*	E	F	G*	H	J	T
AM05	1.55 ± 0.20	2.35 ± 0.20	8.00 ± 0.20	3.50 ± 0.05	1.75 ± 0.10	4.00 ± 0.10	2.00 ± 0.10	4.00 ± 0.10	1.50 -0/+0.10	1.50 Max
AM06	1.95 ± 0.20	3.60 ± 0.20	8.00 ± 0.20	3.50 ± 0.05	1.75 ± 0.10	4.00 ± 0.10	2.00 ± 0.10	4.00 ± 0.1	1.50 -0/+0.10	1.85 Max
AM10	2.70 ± 0.10	3.42 ± 0.10	8.00 ± 0.10	3.50 ± 0.05	1.75 ± 0.10	4.00 ± 0.10	2.00 ± 0.05	4.00 ± 0.10	1.55 -0/+0.10	3.2 Max
AM08	2.20 ± 0.10	4.95 ± 0.10	12.00 ± 0.10	5.50 ± 0.05	1.75 ± 0.10	4.00 ± 0.10	2.00 ± 0.05	4.00 ± 0.10	1.50 -0/+0.10	3.0 Max
AM12	3.66 ± 0.10	4.95 ± 0.10	12.00 ± 0.10	5.50 ± 0.05	1.75 ± 0.10	8.00 ± 0.10	2.00 ± 0.05	4.00 ± 0.10	1.55 -0/+0.10	4.0 Max
AM20	6.2 ± 0.1	6.7 ± 0.1	12.00 ± 0.10	5.50 ± 0.05	1.75 ± 0.10	8.00 ± 0.10	2.00 ± 0.05	4.00 ± 0.10	1.55 -0/+0.10	2.4 ± 0.10

备注：*表示此处对尺寸的要求非常精确。



● 传送带的前后结构

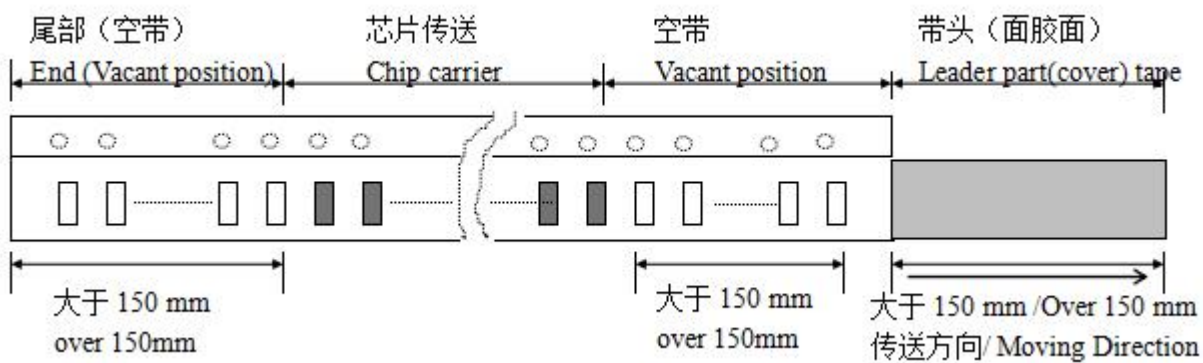

● 卷盘尺寸 (unit: mm)

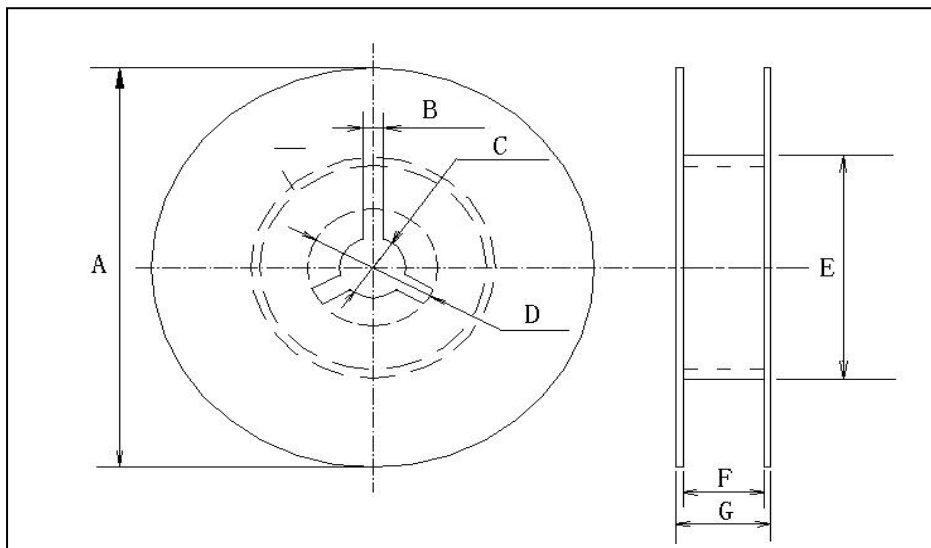

● 尺寸代码 (CODE)

卷盘型号	A	B	C	D	E	F	G
7 REEL	$\phi 178 \pm 2.0$	3.0	$\phi 13 \pm 0.5$	$\phi 21 \pm 0.8$	$\phi 50$ 或更大	100 ± 1.5	12max



● 关于卷带的说明

※ 面胶剥离强度

(a) 纸带

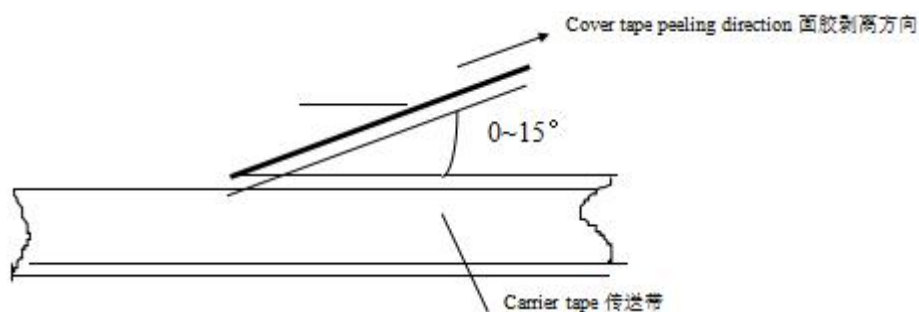

(b) 塑料胶盘

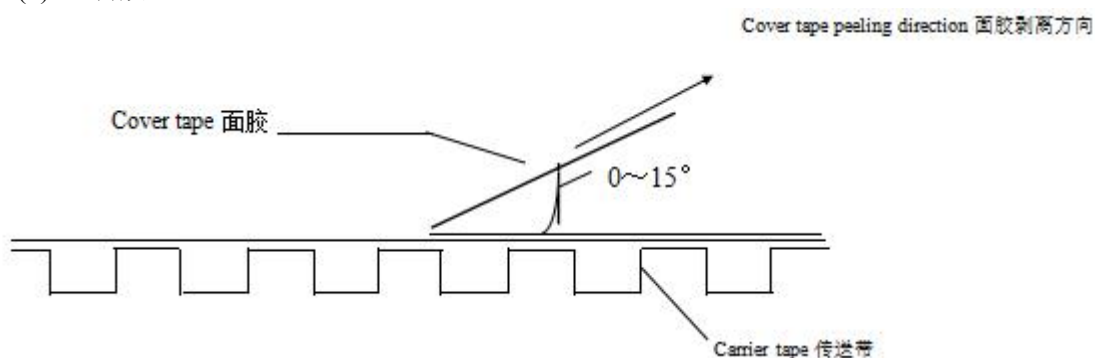

标准：0.1N<剥离强度<0.7N

在剥离时，纸带不能有纸碎，也不能粘在底、面胶上。

※ 塑料盒散包装

单位 (unit) :mm

Symbol	A	B	T	C	D	E
Dimension	6.80±0.10	8.80±1.00	12.00±0.10	15.00+0.10/-0	2.00+0/-0.10	4.70±0.10
Symbol	F	W	G	H	L	I
Dimension	31.50+0.20/-0	36.00+0/-0.20	19.00±0.35	7.00±0.35	110.00±0.70	5.00±0.35

※ 包装数量

尺寸	包装形式和数量 unit: pcs			
	纸带卷盘 (PT)	胶带卷盘 (ET)	塑料盒散装 (BC)	一般散装 (BP)
AM01	15000	-----	-----	-----
AM02	10000	-----	20000	5000
AM03	4000	-----	15000	5000
AM05	4000	3000	10000	5000
AM06	4000	T≤1.35mm 3000 T>1.35mm 2000	5000	5000
AM10	-----	T≤1.80mm 2000 T>1.80mm 1000	-----	2000
AM08	-----	2000	-----	2000
AM12	-----	T≤1.85mm 1000 T>1.85mm 500	-----	2000
AM20	-----	500	-----	-----

注意：包装的形式和数量可根据客户的要求来定。



●外包装

小包装

数量：10 卷

大包装

数量：6 盒

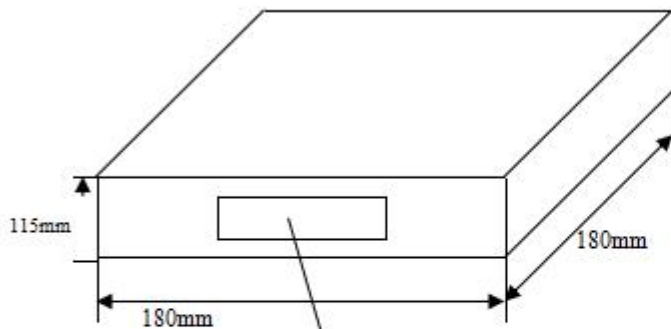

Label 标签

PART No 型号规格
QUANTITY 数量
DATE 日期

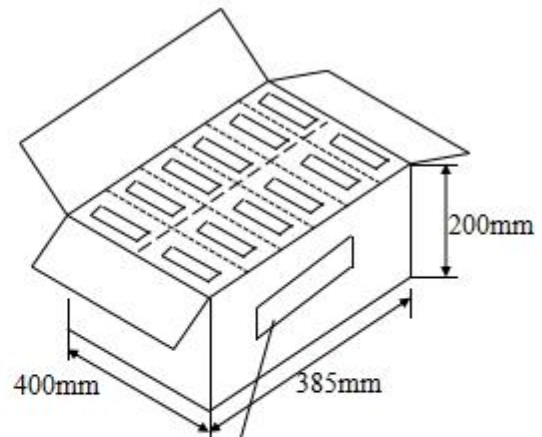

Label 标签

Production name 产品名称
Quantity 数量
Weight 重量

八、储存方法

确保芯片可焊性良好的贮存期限为 12 个月(在包装好已交付的情况下)。

储存条件：

储存温度 5~40℃

储存相对湿度 20~70%

九、使用前的注意事项

多层片式瓷介电容器(MLCC)在短路或开路的电路中都有可能失效,在超出本承认书或相关说明书中所述使用频率的恶劣工作环境,或外界机械力超压作用下,电容芯片都有可能着火、燃烧甚至爆炸,所以在使用的時候,首先应考虑按本承认书的有关说明来进行,如有不明之处,请联系我们技术部、品管部或生产部。

1. 焊接的条件与相关图表

为避免因温度的突然变化而引起的芯片开裂或局部爆炸的现象发生,请按有关温度曲线图表来进行。

2. 手工焊接

手工焊接很容易因为芯片局部受热不均而引起瓷体微裂或局部爆炸的现象,在焊接时,如果操作者不小心,会使烙铁头直接同电容芯片的瓷体部分接触,这样很容易使电容芯片因热冲击而受损或出现其他意外.因此,使用电烙铁手工焊接时应仔细操作,并对电烙铁的尖端的选择和尖端温度控制应多加小心。



3. 适量的焊料

焊料过多

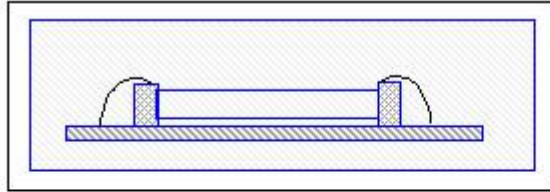

这样会因端头压力过大而可能引起芯片受损

焊料太少

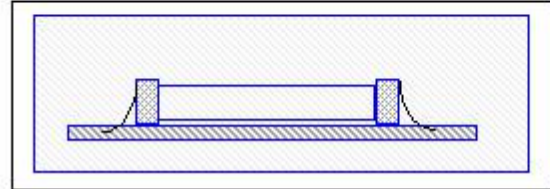

固定力量不足,可能会引起电容芯片与线路接触不良

4. 推荐焊料用量

4.1 回流焊接的最佳焊料用量

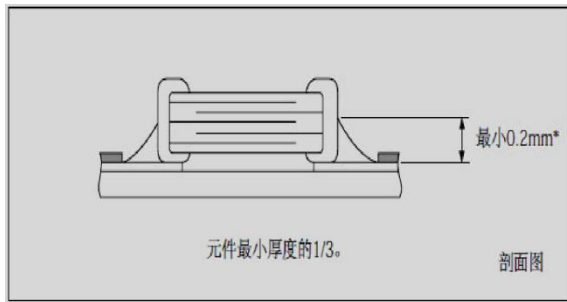

4.2 使用烙铁返修时的最佳焊料量

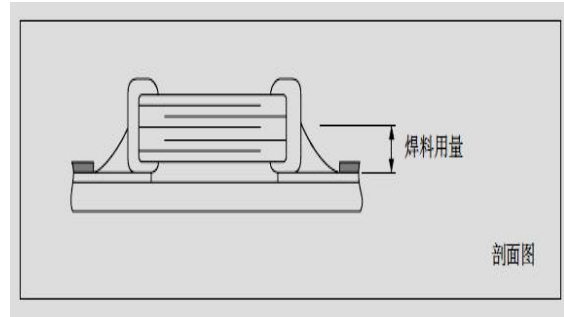

十、推荐焊接方式

规格尺寸	温度特性	焊接方式		温度特性	焊接方式
AM01	NPO	R	AM05	NPO	R
	X7R /X7S/X7T/X5R	R		X7R /X7S/X7T/X5R	R
AM02	NPO	R	AM06	NPO	R
	X7R /X7S/X7T/X5R	R		X7R /X7S/X7T/X5R	R
AM03	NPO	R	≥AM10	NPO	R
	X7R /X7S/X7T/X5R	R		X7R /X7S/X7T/X5R	R

焊接方式：R—回流焊 Reflow Solering



十一、推荐焊接温度曲线图

回流焊接

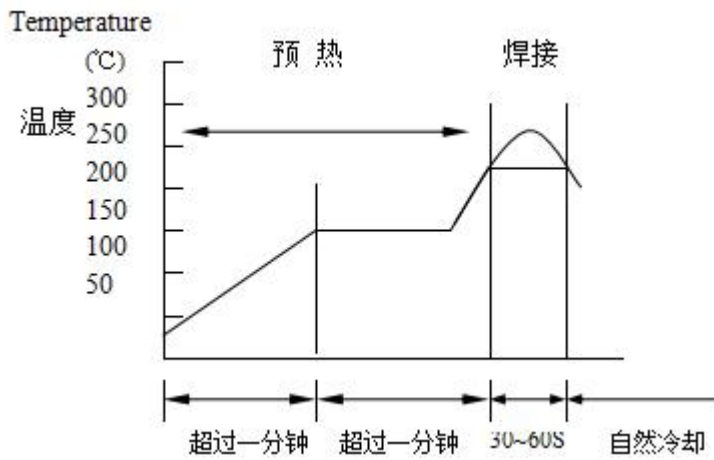

	Pb-Sn 焊接	无铅焊接
尖峰温度	230°C~250°C	240°C~260°C

在预热时，请将焊接温度与芯片表面温度之间的温差维持在 $T \leq 150^\circ\text{C}$ 。

手工焊接

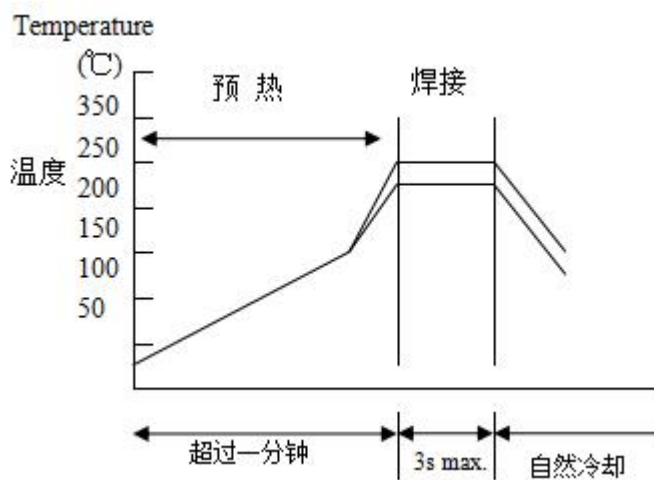

条件:

预热	烙铁头温度	烙铁功率	烙铁头直径	焊接时间	锡膏量	限制条件
$\Delta \leq 130^\circ\text{C}$	最高350°C	最大20W	建议1mm	最长3s	$\leq 1/2$ 芯片厚度	请勿使用烙铁头直接接触陶瓷元件

※以最新版本的内容为准

X-ON Electronics

Largest Supplier of Electrical and Electronic Components

Click to view similar products for [Multilayer Ceramic Capacitors MLCC - SMD/SMT](#) category:

Click to view products by [Fenghua Advanced](#) manufacturer:

Other Similar products are found below :

[M39014/02-1218V](#) [M39014/02-1225V](#) [M39014/22-0631](#) [D55342E07B523DR-T/R](#) [NIN-FB391JTRF](#) [NIN-FC2R7JTRF](#)
[NMC0402NPO220J50TRPF](#) [NMC0402X5R105K6.3TRPF](#) [NMC0402X5R224K6.3TRPF](#) [NMC0402X7R103J25TRPF](#)
[NMC0402X7R392K50TRPF](#) [NMC0603NPO201J50TRPF](#) [NMC0603NPO330G50TRPF](#) [NMC0603NPO331F50TRPF](#)
[NMC0603X5R475M6.3TRPF](#) [NMC0603X7R333K16TRPF](#) [NMC0805NPO220J100TRPF](#) [NMC0805NPO820J50TRPF](#)
[NMC1206X7R102K50TRPF](#) [NMC1206X7R106K10TRPLPF](#) [NMC-H0805X7R472K250TRPF](#) [C1608C0G2A221J](#) [C1608X7R1E334K](#)
[C2012C0G2A472J](#) [2220J2K00562KXT](#) [CCR06CG153FSV](#) [CDR33BX104AKUR](#) [CDR33BX683AKUS](#) [CGA3E1X7R1C684K](#)
[CL10C0R8BB8ANNC](#) [M55342H06B20G0R-T/R](#) [C1005X5R0G225M](#) [C2012X7R2E223K](#) [C3216C0G2J272J](#) [D55342E07B35E7R-T/R](#)
[CDR34BX563BKUS](#) [CDR34BX563BKWS](#) [NMC0402NPO220F50TRPF](#) [NMC0402X7R562J25TRPF](#) [NMC0603NPO102J25TRPF](#)
[NMC1206X7R332K50TRPF](#) [NMC-P1206X7R104K250TRPLPF](#) [726632-1](#) [CGA6M3X7R1H225K](#) [CGA5L2X7R2A105K](#)
[CGA3E2X8R1H223K](#) [CDR33BX823AKUR\M500](#) [CDR33BP132BJUR](#) [CDR35BX474AKUR\M500](#) [CDR35BX104BKUR\M500](#)