



承 认 书

品名： 圆片陶瓷电容器

ITEM: Ceramic Disc Capacitors

制造 MANUFACTURER			客户 CUSTOMER		
拟制 DESIGN	审核 CHECK	批准 APPROVAL	检验 INSPECTOR	审核 CHECK	批准 APPROVAL
陈健业	张锦洪	李际勇			

公司名称：广东风华高新科技股份有限公司正华陶瓷电容器分公司

Company name: Guangdong Fenghua Advanced Technology Holding CO.,LTD
ZhengHua Ceramic Disc Capacitor Branch Company

地 址:广东省肇庆市端州一路工业城 110 号

Address: (Multiple function building),Block 110,Industrial Zone,Duanzhou Ist
Road,Zhaoqing City,Guangdong,P.R.China

电话 (Telephone) :0758-6923812 邮编 (Zip code) :526060



圆片瓷介电容器 Ceramic disc capacitor







客户 Customer name:

产品规格栏 Product specifications											
客户代码 The client code						风华型号 Fenghua models					
(1)						(1)					
(2)						(2)					
(3)						(3)					
NO	额定电压 Voltage	标称容量 Capacitance	容量偏差 Tolerance	温度特性 T.C	外形尺寸(mm)					脚型 Foot type - 包装 Packing	产品标识 Product identification
					成品 Product (D)	成品 Product (T)	线径Φ (d)	脚长 Length (H/L)	间距 Lead spacing (F)		
1											
2											
3											
附注											



圆片瓷介电容器 Ceramicdisc capacitor

安规认证清单表 Safety Certification List

产品系列 Series	CT7 安规（交流）系列产品 CT7 Alternating current disk ceramic capacitor			
证书名称 Certificate name	认证标志 Certification Mark	认证标准 Certification Standard	Y1-Series	Y2-Series
中国 CQC		GB/T6346.14-2015	CQC03001007930	CQC03001007929
德国 VDE		IEC 60384-14 (ed.4)	40013874	40013869
美国 UL		IEC 60384-14 (ed.4)	E219015	
CB 证书	—	EN 60384-14:2013 /AMD1:2016	DE1-62035	DE1-62042
瑞士 SEV		IEC 60384-14 (ed.4) : 2013	19.0469	19.0470
瑞典 SEMKO		EN 60384-14:2013	1911979	1911982
挪威 NEMKO		IEC 60384-14: 2013	P19223835	P19223836
丹麦 DEMKO		EN 60384-14:2013	D-06110-M1	D-06111-M1
芬兰 FIMKO		EN 60384-14:2013 +AMD1:2016	FI/40255	FI/40256
韩国 Korea		KC 60384-1 (2015-09) KC 60384-14 (2015-09)	SU03101-17002	SU03101-17001



圆片瓷介电容器 Ceramic disc capacitor

1 选型参考 Type selection reference

产品类型 Product Type	主要用途 Main application
CC81—I类温度补偿型 Class I -- Temperature compensation capacitor	用于要求损耗值小、容量稳定性要求较高的电路中：谐振回路、高频旁路、温度补偿、控制电路的时间常数元件、稳定性要求高的耦合元件。 Loss value for small and high capacitance stability circuit: the resonant circuit, high-frequency bypass, temperature compensation and control time constant of the circuit components, high stability requirements of coupling components.
CT81—II类高介电常数 Class II -- High dielectric constant	用于对损耗值和容量稳定性要求不高的电路中，如低频旁路、耦合、滤波、退耦等，时间常数元件。 Used for loss value and volume stability of circuits, such as low frequency, by-pass, coupling, filtering, decoupling, etc., the time constant of components.
CT7—交流 Alternating current	交流瓷介电容器适于在电子设备中作为跨电源线连接、天线耦合和旁路等 In ac ceramic capacitor is suitable for electronic equipment as the power cord connection and antenna coupling and bypass, etc
备注 note: 要注意产品类别、材质类别、电压级别、容量级别、外形尺寸的选择。 Pay attention to the product category and material category, the choice of voltage level, capacity level, appearance size.	

2、注意事项 Points to note

瓷介电容器的静电容量易受温度影响，由后面的温度特性曲线可知道：I类产品的容易受温度影响相对偏小，II类、III类产品容量受温度影响呈非线性变化，因此进行容量测试前要把产品在国标规定的标准测试条件 $25 \pm 2^\circ\text{C}$ 的环境下放置 $2 \sim 4$ 小时后再进行测试。

Ceramic capacitor electrostatic capacity is affected by temperature, the temperature characteristic curve of the back know: I products easily affected by temperature is relatively small, II, III product capacity is affected by the temperature change is nonlinear, so the capacity test before to product the standards prescribed by the national standard test conditions to $25 + 2^\circ\text{C}$ placed under the environment of $2 \sim 4$ hours before test.

3、使用温度范围 Operating temperature range :

3.1 国标 (GB) : $-25^\circ\text{C} \sim +85^\circ\text{C}$

3.2 我公司承认 My company admits: $-25^\circ\text{C} \sim +125^\circ\text{C}$

4、应用领域 Application field

广泛适用于家电、照明、通讯、网络、汽车电子等设备中。

Widely used in household appliances, lighting, communications, networking, automotive electronics and other equipment.



圆片瓷介电容器 Ceramic disc capacitor

5、型号构成 Part numbers

编码 Coding	CT7	Y	4	Y5V	0	E	102	M	T	E	A	03
段数 Segment number	(1)	(2)	(3)	(4)	(5)	(6)	(7)	(8)	(9)	(10)	(11)	(12)
											厂商内部代码 Manufacturer's internal code	



段数 Segment number	项目 Projects	编码 Coding
(1)	产品类型 Product Type	NO: 1~4
(2)	额定电压及代码 Rated Voltage and the code	NO: 5
(3)	直径代码 Diameter Code	NO: 6
(4)	温度特性 Temperature Characteristics (T.C.)	NO: 7~9
(5)	引线形式 Lead style	NO: 10
(6)	引线间距 Lead spacing	NO: 11
(7)	标称容量 (额定容量) Rated capacitance	NO: 12~14
(8)	允许偏差 Capacitance Tolerance	NO: 15
(9)	包装形式 Packing style	NO: 16
(10)	环氧树脂包封料颜色 Epoxy color	NO: 17
(11)	内部电极 Internal electrode	NO: 18
(12)	尺寸代码 Size Code	NO: 19~20

5.1 产品类型 Product Type (NO: 1~4)

代码	产品类型
CT7-	交流 (安规) 系列电容器 Alternating current disk ceramic capacitor
CT81	中高压高介电常数系列电容器 High voltage high dielectric constant disk ceramic capacitor
CC81	中高压高压温度补偿系列电容器 High voltage temperature compensation capacitor
CHG-	车规系列产品 Car gauge series products

5.2 额定电压及代码 Rated Voltage and the code (NO: 5)

代码 code	N	M	P	Q	R	S	U	W	T	Z	A	X	Y	B	C
电压 Voltage	1KV DC	2KV DC	3KV DC	4KV DC	5KV DC	6KV DC	8KV DC	10KV DC	12KV DC	15KV DC	20KV DC	250V AC	400V AC	300V AC	500V AC

5.3 直径代码 Diameter Code (NO: 6)

代码 code	4	5	6	7	8	9	10	11
成品尺寸 Finished dimension	7.0max	8.0max	9.0max	10.0max	11.0max	12.0max	13.0max	14.0max
代码 code	12	13	14	15	附注说明 Notes			
成品尺寸 Finished dimension	15.0max	16.0max	17.0max	18.0max	供参考, 具体规格尺寸见《产品规格栏》 For reference, see product specification column for specific specifications			



圆片瓷介电容器 Ceramic disc capacitor

5.4 温度特性 T.C. Temperature Characteristics (NO: 7~9)

材质代码 Material Code		温度特性 Temperature Characteristics (温度范围 Temperature range)	容量允许偏差 Capacity tolerance	工作温度范围 Operating temperature range
Used code	EIA code			
NPO	COH	-25°C ~ +85°C	0 ± 60 PPM/°C	-25°C ~ +125°C
N750	U2J		750 ± 120 PPM/°C	
SL	S2L		+140 ~ -1000 PPM/°C	
DL	S3L		+500 ~ -3300 PPM/°C	
Y5P (B/BN)	Y5P (B/BN)		±10%	
Y5R	Y5R		±15%	
Y5U	Y5U		+22 / -56%	
Y5V	Y5V		+22 / -82%	

5.5 引线形式 Lead style (NO: 10)

代码 code	脚型 Foot type	图示 Pictorial Representation	代码 code	脚型 Foot type	图示 Pictorial Representation
0	前后打翘 Vertical		6	内弯 Inside kink	
1	直脚 (长脚) Straight (Long legs)		7	直脚-改善型 Straight (Improved type)	
3	直脚 (短脚) Straight (Short feet)		9	单外弯 Outside kink	
4	直脚 (编带) Straight (Taping)				

5.6 引线间距 Lead spacing (NO: 11)

代码 code	B	D	E	F	G
脚距 (mm) Lead spacing (mm)	5.0 ± 0.5	7.5 ± 0.5	10.0 ± 0.5	12.5 ± 1.0	15.0 ± 1.0



圆片瓷介电容器 Ceramic disc capacitor

5.7 标称容量 (额定容量) Rated capacitance (NO: 12~14)

代码 Code	容量 capacitance	注: 标称容量以 pF 为单位, 用 3 位数字表示。前两位数字表示有效数字, 第三位为 0 的个数; R 表示小数点。 Note: The unit of standard capacitance if consisting of 3 digits, 1st two digits stand for effective value of the Standard capacitance; third digit indicates the number of zeros; R indicates decimal.
4R7	4.7pF	
330	33pF	
471	470pF	
103	1000pF	

5.8 允许偏差 Capacitance Tolerance (NO: 15)

代码 code	K	M	S	Z
容差 Tolerance	±10%	±20%	+50/-20%	+80%/-20%

5.9 包装形式 Packing style (NO: 16)

代码 code	S	T
包装形式 Packing style	散包装 Bulking	编带包装 Taping

5.10 环氧树脂包封料颜色 Epoxy color (NO: 17)

代码 code	E	F
环氧树脂 Epoxy	黄色 Yellow	蓝色 Blue

5.11 内部电极 Internal electrode (NO: 18)

代码 code	A	C	附注说明 Notes: 仅内部使用, 不做对外承认。 For internal use only, without external recognition
电极 Electrode	银 Ag	铜 Cu	

5.12 尺寸代码 Size Code (NO: 19~20)

适用编带产品 (步距尺寸单位: mm) Taping products (step:mm)											
代码 code	尺寸 Dimensions	代码 code	尺寸 Dimensions	代码 code	尺寸 Dimensions	代码 code	尺寸 Dimensions				
01	12.7-盒装 (Boxed)	03	25.4-盒装 (Boxed)	05	12.7-卷装 (Roll Up)	07	25.4-卷装 (Roll Up)				
02	15.0-盒装 (Boxed)	04	30.0-盒装 (Boxed)	06	15.0-卷装 (Roll Up)	08	30.0-卷装 (Roll Up)				
适用散装产品 (引脚尺寸单位: mm)											
代码 code	尺寸 Dimensions	代码 code	尺寸 Dimensions	代码 code	尺寸 Dimensions	代码 code	尺寸 Dimensions	代码 code	尺寸 Dimensions	代码 code	尺寸 Dimensions
A0	2.0	B0	3.0	C0	4.0	D0	5.0	E0	6.0	F0	7.0
A1	2.1	B1	3.1	C1	4.1	D1	5.1	E1	6.1	F1	7.1
A2	2.2	B2	3.2	C2	4.2	D2	5.2	E2	6.2	F2	7.2
A3	2.3	B3	3.3	C3	4.3	D3	5.3	E3	6.3	F3	7.3
A4	2.4	B4	3.4	C4	4.4	D4	5.4	E4	6.4	F4	7.4
A5	2.5	B5	3.5	C5	4.5	D5	5.5	E5	6.5	F5	7.5
A6	2.6	B6	3.6	C6	4.6	D6	5.6	E6	6.6	F6	7.6
A7	2.7	B7	3.7	C7	4.7	D7	5.7	E7	6.7	F7	7.7
A8	2.8	B8	3.8	C8	4.8	D8	5.8	E8	6.8	F8	7.8
A9	2.9	B9	3.9	C9	4.9	D9	5.9	E9	6.9	F9	7.9
适用散装产品 (引脚尺寸单位: mm)											
代码 code	尺寸 Dimensions	代码 code	尺寸 Dimensions	代码 code	尺寸 Dimensions	代码 code	尺寸 Dimensions			代码 code	尺寸 Dimensions
G0	8.0	H0	9.0	I0	10.0	J0	11.0			T0	20.0
.	无 None	无 None			无 None	无 None
G9	8.9	H9	9.9	I0	10.9						

附注: 剪脚品, 对应代码表示引脚尺寸的中心值; 长引脚品统一使用“T0”代表最小的尺寸为 20mm
Notes: Cut Pin products, the corresponding code represents the central value of pin size; long pin products uniform use "t 0" represents the minimum size of 20 mm



圆片瓷介电容器 Ceramic disc capacitor

6、编带尺寸 Taping

6.1 直脚编带 Straight taping

引线形式代码 Lead style code: **4** Unit: mm

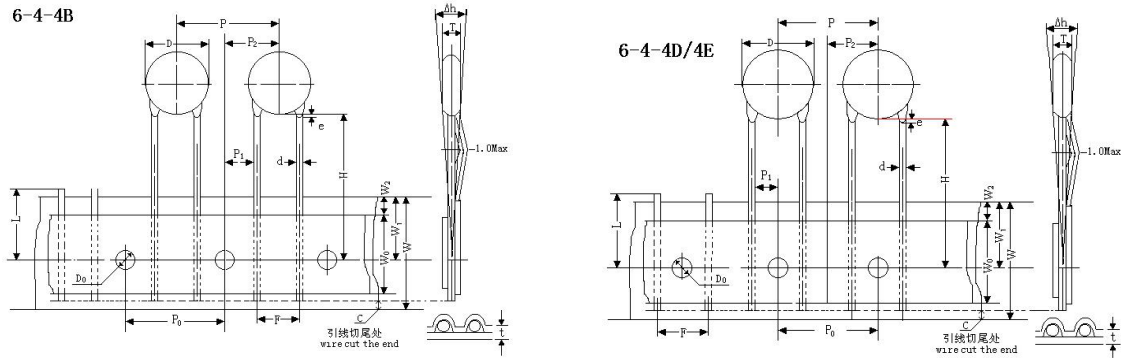

单位: mm

序号 No.	符号 Code	引线代码 lead code		引线代码 Lead code	
		≤ 10.0	≤ 10.0	≤ 13.0	≤ 13.0
1	D	≤ 10.0	≤ 10.0	≤ 13.0	——
2	P	12.7 ± 2.0	12.7 ± 2.0	15.0 ± 2.0	15.0 ± 2.0
3	P ₀	12.7 ± 0.3	12.7 ± 0.3	15.0 ± 0.3	12.7 ± 0.3
4	P ₁	3.85 ± 0.7	2.6 ± 0.7	3.75 ± 0.7	2.5 ± 0.7
5	P ₂	6.35 ± 1.0	6.35 ± 1.0	7.5 ± 1.0	7.5 ± 1.0
6	F	5.0 ± 0.5	7.5 ± 0.5	10.0 ± 0.5	
7	d	0.50 ± 0.08	$0.50/0.60 \pm 0.08$	0.60 ± 0.08	
8	e	2.0 Max 或弯折卡位内			
9	H	20.0 ± 2.0	20.0 ± 2.0	20.0 ± 2.0	
10	Δh	2.0 Max	2.0 Max	2.0 Max	
11	T	4.0 Max	5.0 Max	6.0 Max	
12	D ₀	4.0 ± 0.2	4.0 ± 0.2	4.0 ± 0.2	
13	W	18.0 ± 0.5	18.0 ± 0.5	18.0 ± 0.5	
14	W ₀	7.5 Min	9.0 Min	9.0 Min	
15	W ₁	9.0 ± 0.5	9.0 ± 0.5	9.0 ± 0.5	
16	W ₂	1.5 ± 1.5	1.5 ± 1.5	1.5 ± 1.5	
17	L	11.0 Max	11.0 Max	11.0 Max	
18	C	0~5.0	0~5.0	0~5.0	
19	t	0.7 ± 0.2	0.7 ± 0.2	0.7 ± 0.2	
20	h	4.0Max	4.0Max	4.0Max	



圆片瓷介电容器 Ceramic disc capacitor

6.2 内弯编带 Inside kink taping

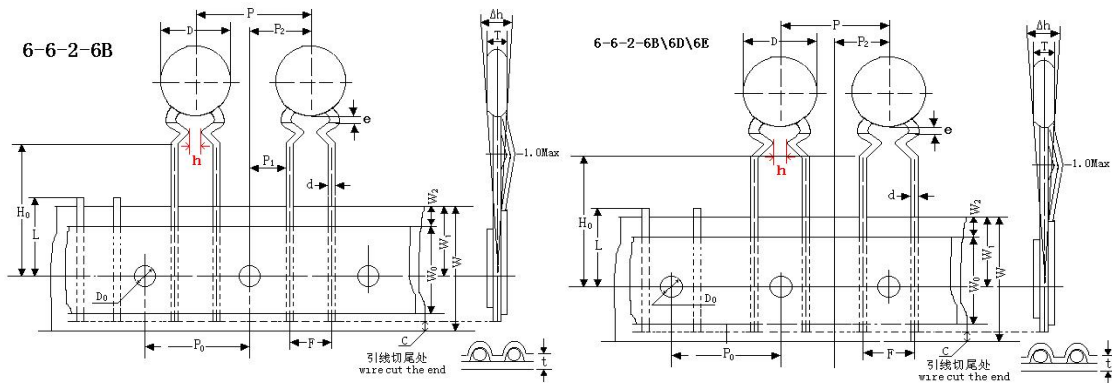

单位: mm

序号 No.	符号 Code	引线代码 lead code	引线代码 Lead code		引线代码 Lead code	
1	D	≤ 10.0	≤ 10.0	≤ 13.0	≤ 13.0	——
2	P	12.7 ± 2.0	12.7 ± 2.0	15.0 ± 2.0	15.0 ± 2.0	25.4 ± 2.0
3	P ₀	12.7 ± 0.3	12.7 ± 0.3	15.0 ± 0.3	15.0 ± 0.3	12.7 ± 0.3
4	P ₁	3.85 ± 0.7	2.6 ± 0.7	3.75 ± 0.7	2.5 ± 0.7	7.7 ± 0.7
5	P ₂	6.35 ± 1.0	6.35 ± 1.0	7.5 ± 1.0	7.5 ± 1.0	12.7 ± 1.0
6	F	5.0 ± 0.5	7.5 ± 0.5		10.0 ± 0.5	
7	d	0.50 ± 0.08	$0.50/0.60 \pm 0.08$		0.60 ± 0.08	
8	e	2.0 Max 或弯折卡位内				
9	H	18.0 ± 2.0	18.0 ± 2.0	18.0 ± 2.0		
10	Δh	2.0 Max	2.0 Max		2.0 Max	
11	T	4.0 Max	5.0 Max		6.0 Max	
12	D ₀	4.0 ± 0.2	4.0 ± 0.2		4.0 ± 0.2	
13	W	18.0 ± 0.5	18.0 ± 0.5		18.0 ± 0.5	
14	W ₀	7.5 Min	9.0 Min		9.0 Min	
15	W ₁	9.0 ± 0.5	9.0 ± 0.5		9.0 ± 0.5	
16	W ₂	1.5 ± 1.5	1.5 ± 1.5		1.5 ± 1.5	
17	L	11.0 Max	11.0 Max		11.0 Max	
18	C	0~5.0	0~5.0		0~5.0	
19	t	0.7 ± 0.2	0.7 ± 0.2		0.7 ± 0.2	
20	h	4.0Max	4.0Max		4.0Max	



圆片瓷介电容器 Ceramic disc capacitor

6.3 单外弯编带 Single Outside kink tapping

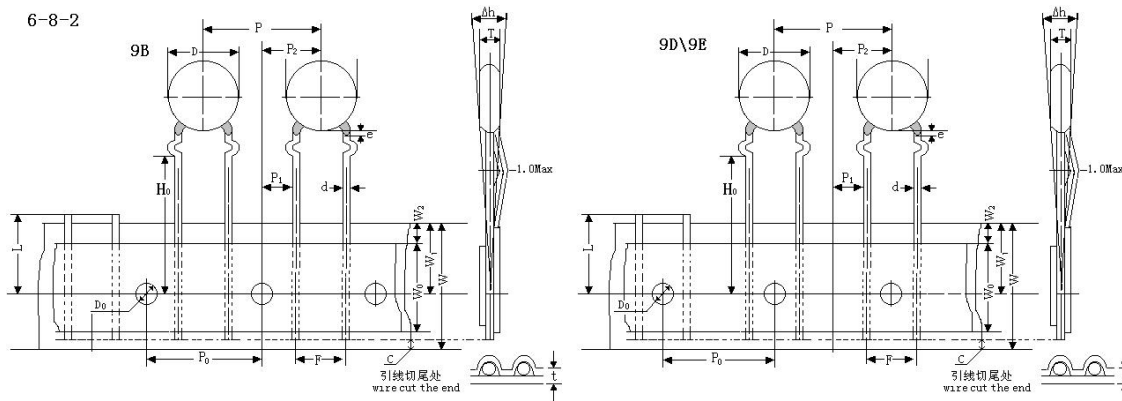

单位: mm

序号 No.	符号 Code	引线代码 lead code	引线代码 Lead code		引线代码 Lead code	
1	D	≤ 10.0	≤ 10.0	≤ 13.0	≤ 13.0	——
2	P	12.7 ± 2.0	12.7 ± 2.0	15.0 ± 2.0	15.0 ± 2.0	25.4 ± 2.0
3	P ₀	12.7 ± 0.3	12.7 ± 0.3	15.0 ± 0.3	15.0 ± 0.3	12.7 ± 0.3
4	P ₁	3.85 ± 0.7	2.6 ± 0.7	3.75 ± 0.7	2.5 ± 0.7	7.7 ± 0.7
5	P ₂	6.35 ± 1.0	6.35 ± 1.0	7.5 ± 1.0	7.5 ± 1.0	12.7 ± 1.0
6	F	5.0 ± 0.5	7.5 ± 0.5		10.0 ± 0.5	
7	d	0.50 ± 0.08	$0.50/0.60 \pm 0.08$		0.60 ± 0.08	
8	e	2.0 Max 或弯折卡位内				
9	H	18.0 ± 2.0	18.0 ± 2.0		18.0 ± 2.0	
10	Δh	2.0 Max	2.0 Max		2.0 Max	
11	T	4.0 Max	5.0 Max		6.0 Max	
12	D ₀	4.0 ± 0.2	4.0 ± 0.2		4.0 ± 0.2	
13	W	18.0 ± 0.5	18.0 ± 0.5		18.0 ± 0.5	
14	W ₀	7.5 Min	9.0 Min		9.0 Min	
15	W ₁	9.0 ± 0.5	9.0 ± 0.5		9.0 ± 0.5	
16	W ₂	1.5 ± 1.5	1.5 ± 1.5		1.5 ± 1.5	
17	L	11.0 Max	11.0 Max		11.0 Max	
18	C	0~5.0	0~5.0		0~5.0	
19	t	0.7 ± 0.2	0.7 ± 0.2		0.7 ± 0.2	
20	h	4.0Max	4.0Max		4.0Max	



圆片瓷介电容器 Ceramic disc capacitor

6.4 前后翘编带 Vertical crimp lead taping

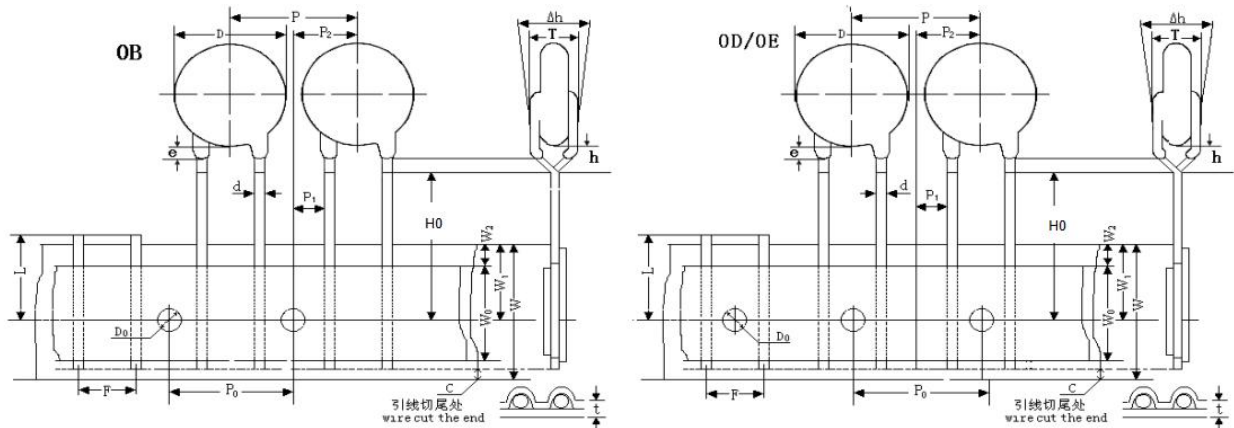

单位: mm

序号 No.	符号 Code	引线代码 lead code	引线代码 Lead code		引线代码 Lead code	
1	D	≤ 10.0	≤ 10.0	≤ 13.0	≤ 13.0	——
2	P	12.7 ± 2.0	12.7 ± 2.0	15.0 ± 2.0	15.0 ± 2.0	25.4 ± 2.0
3	P ₀	12.7 ± 0.3	12.7 ± 0.3	15.0 ± 0.3	15.0 ± 0.3	12.7 ± 0.3
4	P ₁	3.85 ± 0.7	2.6 ± 0.7	3.75 ± 0.7	2.5 ± 0.7	7.7 ± 0.7
5	P ₂	6.35 ± 1.0	6.35 ± 1.0	7.5 ± 1.0	7.5 ± 1.0	12.7 ± 1.0
6	F	5.0 ± 0.5	7.5 ± 0.5		10.0 ± 0.5	
7	d	0.50 ± 0.08	$0.50/0.60 \pm 0.08$		0.60 ± 0.08	
8	e	2.0 Max 或弯折卡位内				
9	H ₀	18.0 ± 2.0	18.0 ± 2.0		18.0 ± 2.0	
10	Δh	2.0 Max	2.0 Max		2.0 Max	
11	T	4.0 Max	5.0 Max		6.0 Max	
12	D ₀	4.0 ± 0.2	4.0 ± 0.2		4.0 ± 0.2	
13	W	18.0 ± 0.5	18.0 ± 0.5		18.0 ± 0.5	
14	W ₀	7.5 Min	9.0 Min		9.0 Min	
15	W ₁	9.0 ± 0.5	9.0 ± 0.5		9.0 ± 0.5	
16	W ₂	1.5 ± 1.5	1.5 ± 1.5		1.5 ± 1.5	
17	L	11.0 Max	11.0 Max		11.0 Max	
18	C	0~5.0	0~5.0		0~5.0	
19	t	0.7 ± 0.2	0.7 ± 0.2		0.7 ± 0.2	
20	h	4.0Max	4.0Max		4.0Max	



圆片瓷介电容器 Ceramic disc capacitor

7、产品标示 product marking

7.1 高频产品标示

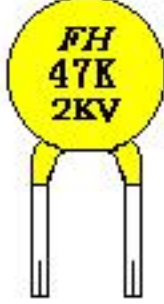
序号 No.	标示项目 Marking Items	代码 code	图例 legend
1	风华商标 FH logo	FH	
2	标称容量 Rated capacitance	47(47pF)	
3	容量偏差 Capacitance tolerance	K($\pm 10\%$)	
4	额定电压 Rated voltage	2KVDC	

7.1 低频产品标示

序号 No.	标示项目 Marking Items	代码 code	图例 legend
1	风华商标 FH logo	FH	
2	温度特性(T.C.)	F(Y5V)	
3	标称容量 Rated capacitance	102(1000pF)	
4	容量偏差 Capacitance tolerance	K($\pm 10\%$)	
5	额定电压 Rated voltage	2KVDC	



圆片瓷介电容器 Ceramic disc capacitor

8、产品额定值 Product rated parameters

(温度特性、额定电压、标称容量、容量偏差、引线间距、本体直径、本体厚度) T.C.、Rated voltage、Rated capacitance、Capacitance Tolerance、Lead spacing、Body Diameter、Body Thickness

产品类型 Product Type	温度 特性 T.C.	额定电压 Rated voltage(V)	标称容量 Rated capacitance (pF)	允许偏差 Capacitance Tolerance (%)	芯片直径 Chip diameter (mm)	成品直径 Finished diameter(mm)	成品厚度 Finished thickness(mm)
CC81	N750	1KV(N)	10~30	±10%(K)	3.5~5.5	6.5 Max	3.5Max
	SL		33~56		3.5~5.5		
			68~101		5.0~6.5	7.5Max	
	SL	2KV(M)	22~56	±10%(K)	3.5~5.5	6.5 Max	4.0Max
			68~101		5.0~6.5	7.5 Max	
	N750	3KV(P)	22	±10%(K)	3.5~5.5	6.5 Max	5.0Max
	SL		27~47		3.5~5.5		
			68		5.5~6.5	7.5 Max	
			82~101		7.0~8.5	9.5 Max	
	CT81	Y5P	1KV(N)	151~681	±10%(K)	3.5~5.5	6.5 Max
821~102				5.0~6.5		7.5Max	
152~222				6.0~8.4		9.5Max	
182~222				6.5~8.5		9.5Max	
272~392				7.5~9.5		10.5Max	
472				11.3~12.5		14.0Max	4.0Max
2KV(M)			101~391	±10%(K)	3.5~5.5	6.5 Max	4.0Max
			471~681		5.0~6.5	7.5Max	
			102~132		6.0~7.5	8.5Max	
			152~172		7.5~8.5	9.5Max	
			182~222		8.5~10.5	11.5Max	
			352~272		9.5~11.5	13.0Max	4.5Max
332~392			11.5~12.5	14.0Max			
3KV(P)			101~471	±10%(K)	3.5~5.5	7.5 Max	5.0Max
			471~821		5.5~7.5	9.5Max	
			901~172		7.0~9.5	11.5Max	
			182~302		9.5~12.5	14.5Max	
附注 Notes			若需 4KV~15KV 的, 请提供贵司的参数要求, 我会参照要求提供对应的尺寸, 谢谢! If need 4KV ~ 15KV, please provide your company's parameter request, we will provide the corresponding size according to the request, thanks!				



圆片瓷介电容器 Ceramicdisc capacitor

产品类型 Product Type	温度特性 T.C.	额定电压 Rated voltage(V)	标称容量 Rated capacitance(pF)	允许偏差 Capacitance Tolerance(%)	芯片直径 Chip diameter (mm)	成品直径 Finished diameter(mm)	成品厚度 Finished thickness(mm)		
CT81	Y5U	1KV(N)	102~362	±20%(M) +80/-20%(Z)	3.5~5.5	6.5 Max	3.5Max		
			392~562		5.6~7.4	8.5Max			
			692~872		7.5~8.4	9.5Max			
			103		8.5~9.4	10.5Max			
		2KV(M)	821~202	±20%(M) +80/-20%(Z)	3.5~5.5	6.5 Max	4.0Max		
			202~272		5.5~6.4	7.5Max			
			332~392		6.5~7.4	8.5Max			
			472、502		7.5~8.4	9.5Max			
			602~682		8.5~9.4	10.5Max			
			702~922		9.5~11.5	13.5Max			
			103		1.5~12.5	14.5Max		4.5Max	
		3KV(P)	621~142	±20%(M) +80/-20%(Z)	3.5~5.5	7.0 Max	5.0Max		
			142~182		5.5~6.4	8.0Max			
			202~272		6.5~7.4	9.0Max			
			302~372		7.5~8.4	10.0Max			
			382~472		8.5~9.4	12.0Max			
			502~822		9.5~12.5	14.5Max			
		CT81	Y5V	1KV(N)	102~222	±20%(M) +80/-20%(Z)	3.5~5.5	6.5 Max	3.5Max
222~332	5.5~6.4				7.5Max				
472~682	6.5~7.4				8.5Max				
682~822	7.5~8.4				9.5Max				
822~103	8.5~9.4				10.5Max				
2KV(M)	182~332			±20%(M) +80/-20%(Z)	3.5~5.4	6.5 Max	4.0Max		
	352~472				5.5~6.4	7.5Max			
	562~702				6.5~7.4	8.5Max			
	392~472				7.5~8.4	9.5Max			
	792~103				8.5~9.4	11.0Max			
3KV(P)	102~252			±20%(M) +80/-20%(Z)	3.5~5.4	8.5Max	5.0Max		
	262~332				5.5~6.4	9.5Max			
	392~472				6.5~7.4	10.5Max			
	562~652				7.5~8.4	11.5Max			
	682~852				8.5~9.4	12.5Max			
	103				11.5~12.4	14.5Max			
附注 Notes	若需 4KV~15KV 的, 请提供贵司的参数要求, 我会参照要求提供对应的尺寸, 谢谢! If need 4KV ~ 15KV, please provide your company's parameter request, we will provide the corresponding size according to the request, thanks!								



圆片瓷介电容器 ceramic disc capacitor

产品类型 Product Type	温度特性 T.C.	额定电压 Rated voltage(V)	标称容量 Rated capacitance(pF)	允许偏差 Capacitance Tolerance(%)	芯片直径 Chip diameter (mm)	成品直径 Finished diameter(mm)	成品厚度 Finished thickness(mm)	
CT7	Y5P	X: 250VAC	101~481	±10%(K)	3.5~5.4	7.5 Max	5.0Max	
			491~711		5.5~6.4	8.5Max		
			721~991		6.5~7.4	9.5Max		
		B: 300VAC	102~122		7.5~8.4	10.5Max		
			132~152		8.5~9.4	11.5Max		
	Y5U	X: 250VAC	681~132	±20%(M)	3.5~5.4	7.5 Max	5.0Max	
			142~192		5.5~6.4	8.5Max		
			202~262		6.5~7.4	9.5Max		
		B: 300VAC	272~322		+80/-20%(Z)	7.5~8.4		10.5Max
			332~432		8.5~9.4	11.5Max		
	472~682	10.0~12.4	14.5Max					
	Y5V	X: 250VAC B: 300VAC	102~232	±20%(M)	3.5~5.4	7.5 Max	5.0Max	
			242~332		5.5~6.4	8.5Max		
			342~472		6.5~7.4	9.5Max		
			482~572		+80/-20%(Z)	7.5~8.4		10.5Max
582~742			8.5~9.4		11.5Max			
752~103	10.0~12.0	14.5Max						

产品类型 Product Type	温度特性 T.C.	额定电压 Rated voltage(V)	标称容量 Rated capacitance(pF)	允许偏差 Capacitance Tolerance(%)	芯片直径 Chip diameter (mm)	成品直径 Finished diameter(mm)	成品厚度 Finished thickness(mm)	
CT7	Y5P	Y: 400VAC C: 500VAC	101~351	±10%(K)	3.5~5.4	7.5 Max	6.0Max	
			361~471		5.5~6.4	8.5Max		
			481~651		6.5~7.4	9.5Max		
			661~841		7.5~8.4	10.5Max		
			851~102		8.5~9.4	11.5Max		
	Y5U	Y: 400VAC C: 500VAC	471~102	±20%(M)	3.5~5.4	7.5 Max	6.0Max	
			102~132		5.5~6.4	8.5Max		
			142~182		6.5~7.4	9.5Max		
			192~222		+80/-20%(Z)	7.5~8.4		10.5Max
			232~292		8.5~9.4	11.5Max		
			302~332		9.5~10.4	12.5Max		
	472	11.5~12.4	14.5Max					
	Y5V	Y: 400VAC C: 500VAC	821~172	±20%(M)	3.5~5.4	7.5Max	6.0Max	
			172~222		5.5~6.4	8.5Max		
			222~312		6.5~7.4	9.5Max		
322~392			+80/-20%(Z)		7.5~8.4	10.5Max		
402~472	8.5~9.4	11.5Max						



圆片瓷介电容器 ceramic disc capacitor

9、可靠性测试方法 Specification and test method

项 目 Item	性 能 Performances			试验方法及条件 Test method			
1、外观构造及尺寸 appearance and dimension	外观无异常 构造及尺寸依图示规定 No damage in appearance and dimension accord with fixed			目视检验尺寸以游标卡尺测量 Venire caliper			
2、静电容量 Capacitance	规定之容许误差以内 Within specified tolerance			测试频率和测试电压 Measuring frequency & Measuring voltage: 1、CC81: $1 \pm 0.1\text{MHz}$, 1.0Vrms 2、CT81、CT7: $1 \pm 0.1\text{kHz}$, 1.0Vrms 测试温度 Measuring temperature: $25 \pm 2^\circ\text{C}$			
3、损耗角正切值 Loss angle Tangent value $T_g \delta$ (散逸因数 Dissipation Factor)	CC81	NPO N750 SL	≤ 0.0015				
	CT81	Y5R	≤ 0.005				
		Y5P	BN				≤ 0.005
			B				≤ 0.025
	CT7 CHG	Y5U	≤ 0.030				
		Y5V	≤ 0.035				
4、绝缘电阻 (端子间.) Insulation resistance (I.R) Between lead wire	CC81	$\geq 10000\text{M}\Omega$		测试电压 Test voltage	500VDC	施加时间 Application time: $60 \pm 5\text{S}$	
	CT81	$\geq 10000\text{M}\Omega$			500VDC		
	CT7 CHG	$\geq 10000\text{M}\Omega$			500VDC		



圆片瓷介电容器 ceramic disc capacitor

项 目 Item		性 能 Performances		试验方法及条件 Test method							
5、耐电压 Voltage-Proof	端子间 Between terminations	无不良 No bad result		测试电压 Test voltage	<table border="1"> <tr> <td>CC81</td> <td>≤5KV: 1.5U_R+500V</td> </tr> <tr> <td>CT81</td> <td>≥6KV: U_R+500V</td> </tr> <tr> <td>CT7 (CHG)</td> <td>10 U_R</td> </tr> </table>	CC81	≤5KV: 1.5U _R +500V	CT81	≥6KV: U _R +500V	CT7 (CHG)	10 U _R
	CC81	≤5KV: 1.5U _R +500V									
	CT81	≥6KV: U _R +500V									
	CT7 (CHG)	10 U _R									
端子与外装间 Between terminations and enclosure	无不良 No bad result	施加时间 Application time	逐批检验 Lot by lot inspection: 5S								
		鉴定和周期检验 Identification and periodic Inspection: 60S									
		充放电电流 Charge/discharge current : ≤50mA									
金属小球法 Small metallic ball method is used											
测试电压 Test voltage	<table border="1"> <tr> <td>CC81</td> <td rowspan="2">3000VDC</td> </tr> <tr> <td>CT81</td> </tr> <tr> <td>CT7 (CHG)</td> <td>10U_R</td> </tr> </table>	CC81	3000VDC	CT81	CT7 (CHG)	10U _R					
CC81	3000VDC										
CT81											
CT7 (CHG)	10U _R										
施加时间 Application time : 60S											
充放电电流 Charging/discharging current: ≤50mA											
6、温度特性 Temperature Characteristics	未施加电压 Without voltage application	在允许规格范围内 <Within specified tolerance>		依次按以下温度循环阶段测定 According to the following in temperature cycle phase measurement							
施加额定电压 Rated voltage applied	NPO N750 SL B/R E (Y5U) F (Y5V)	在 ± 3% 或 ± 0.03PF 以内, 取较大者为准 Within ±3% or ±0.03PF, based upon whichever is higher	+10/-15% +20/-60% +30/-80%	阶段 Step	温度(°C) Temperature						
				1	20°C						
				2	NPO\N750\SL	-55°C					
					Y5P\Y5R\Y5U\Y5V	-25°C					
				3	20°C						
				4	NPO\N750\SL	+125°C					
					Y5P\Y5R\Y5U\Y5V	+85°C					
5	20°C										
				TC: 为相对于 20±2°C时的容量变化率 TC: Volume change rate relative to 20 ± 2 °C							



圆片瓷介电容器 ceramic disc capacitor

项 目 Item		性 能 Performances	试验方法及条件 Test method		
7、 端子强度 Robustness Of Termination	抗拉强度 Tensile strength	引线不断裂， 电容器不破损 No abnormalities such as breaking or loosening of termination	电容器轴方向加重量 <Apply the tension in the direction of emergence of termination>		
			线径(mm) Wire diameter	拉力(Kg) Tensile force	持续时间(s) time of duration
			0.31~0.49	0.5kgf	10±1
	0.50~0.80	1.0kgf			
	弯曲强度 Bending strength	引线不断裂， 电容器不破损 No abnormalities such as breaking or loosening of termination	导线垂直方向加重向下，本体向左 90° 弯曲试验 2 次。 Apply the tension in the direction of vertical and bend it for 90° , after reset, bend it for 90° in reverse direction twice		
			线径 (mm) Wire diameter	拉力(Kg) Tensile force	
0.31~0.49			0.25		
			0.50~0.80	0.5	
8、耐振性 Vibration- Resistance	外观 Appearance	无显著异常 并且容易判断出来 No remarkable abnormality and marking shall be easily legible	频率依次为：10Hz→55Hz→10Hz 振幅：0.75mm，持续时间：60S。 Frequency is as follows： 10Hz→55Hz→10Hz Amplitude: 0.75 mm length of time: 60 S		
	静电容量 Capacitance	规格之容许差以内 Within specified tolerance	在 X、Y、Z 三个互相垂直的方向各振动 2 小时，产品无破损、开裂等不良现象。 In the X, Y, Z three mutually perpendicular direction the vibration 2 hours, the products without damage, cracking and other unhealthy phenomenon.		
	损耗角 正切值 Loss angle tangent value tgδ	满足项目 5 的要求 To satisfy Number 5			
9、可焊性 Solder ability		引线表面均匀沾锡，上 锡面积不小于总面积的 95% Lead uniformly on the surface of tin, tin area of not less than 95% of the total area.	焊锡温度 Soldering Temperature	265±5℃	
			浸入时间 Dipping Time	2.0±0.5S	
			上锡面积 Tin area	≥95%	
			浸入深度：距离电容本体 2.0±0.5mm Immersion depth : Distance capacitance body 2.5±0.5mm		



圆片瓷介电容器 ceramic disc capacitor

项 目 Item		性 能 Performances		试验方法及条件 Test method		
10、 耐 焊 接 热 Welding heat resistant ability	外观 Appearance	无显著异常并且容易判断出来 No remarkable abnormality and marking shall be easily legible		预处理：在 $125 \pm 2^\circ\text{C}$ 温度下放置 1 小时，在常温下恢复 24 ± 2 小时后测试。 Pretreatment: Capacitor shall be stored at $125 \pm 2^\circ\text{C}$ for 1 hour, then placed at room condition for 24 ± 2 hour before test.		
	静电容量变化率 Relative capacitance change	NPO	在 $\pm 2.5\%$ 或 $\pm 0.25\text{PF}$ 以内，取较大者为准 Within $\pm 2.5\%$ or $\pm 0.25\text{PF}$, based upon whichever is higher	焊接温度 Soldering Temperature	350	260
		N750			$\pm 10^\circ\text{C}$	$\pm 5^\circ\text{C}$
		SL		焊接时间 Dipping Time	3.5	10
		B/R	$\pm 0.5\text{sec}$		$\pm 1\text{sec}$	
		E (Y5U)	浸入深度：引线部分有 1.5~2.0mm 在锡面以上。 Immersion depth: Lead part 1.5~2.0mm in the solder side above.			
F (Y5V)	$\pm 20\%$					
耐电压 Voltage-proof (端子间) (between terminations)	参照项目 5 内容 With reference to the project 5 content		<p style="text-align: right;">8-1</p>			
				后处理：电容器应当在室温下放置 1~2 小时。 Post processing: Capacitor shall be stored for 1~2h at room condition, before test.		



圆片瓷介电容器 ceramic disc capacitor

项 目 Item		性 能 Performances		试验方法及条件 Test method																																
11、 冷热冲击 Hot and cold shock (温度循环 Temperature cycle)	外观 Appearance	无显著异常并且容易判断出来 No remarkable abnormality and marking shall be easily legible		1、预处理：在 $125 \pm 2^\circ\text{C}$ 温度下放置 1 小时，在常温下恢复 24 ± 2 小时后测试。 Pretreatment: Capacitor shall be stored at $125 \pm 2^\circ\text{C}$ for 1 hour, than placed at room condition for $24 \pm 2^\circ\text{C}$ hour before test. 2、按下列步骤循环 5 次： The capacitance measurement shall be made at each step specified in Table, The capacitor shall be subjected to 5 temperature cycles. a、CC81 (NPO、N750、SL) <table border="1" style="width: 100%; text-align: center;"> <thead> <tr> <th>步骤 Step</th> <th>温度$^\circ\text{C}$ temperature</th> <th>时间(分钟) Time (minute)</th> </tr> </thead> <tbody> <tr> <td>1</td> <td>-55 ± 2</td> <td>30 ± 3</td> </tr> <tr> <td>2</td> <td>$+25 \pm 2$</td> <td>≤ 3</td> </tr> <tr> <td>3</td> <td>$+125 \pm 2$</td> <td>30 ± 3</td> </tr> <tr> <td>4</td> <td>$+25 \pm 2$</td> <td>≤ 3</td> </tr> </tbody> </table> b、CT81、CT7、CHG (Y5P、Y5U、Y5V) <table border="1" style="width: 100%; text-align: center;"> <thead> <tr> <th>步骤 Step</th> <th>温度$^\circ\text{C}$ temperature</th> <th>时间(分钟) Time (minute)</th> </tr> </thead> <tbody> <tr> <td>1</td> <td>-25 ± 2</td> <td>30 ± 3</td> </tr> <tr> <td>2</td> <td>$+25 \pm 2$</td> <td>≤ 3</td> </tr> <tr> <td>3</td> <td>$+125 \pm 2$</td> <td>30 ± 3</td> </tr> <tr> <td>4</td> <td>$+25 \pm 2$</td> <td>≤ 3</td> </tr> </tbody> </table> 3、后处理：在室温条件下恢复 24 ± 2 小时后测试。 Post processing: Capacitor shall be stored for $24 \pm 2\text{h}$ at room condition, before test.			步骤 Step	温度 $^\circ\text{C}$ temperature	时间(分钟) Time (minute)	1	-55 ± 2	30 ± 3	2	$+25 \pm 2$	≤ 3	3	$+125 \pm 2$	30 ± 3	4	$+25 \pm 2$	≤ 3	步骤 Step	温度 $^\circ\text{C}$ temperature	时间(分钟) Time (minute)	1	-25 ± 2	30 ± 3	2	$+25 \pm 2$	≤ 3	3	$+125 \pm 2$	30 ± 3	4	$+25 \pm 2$	≤ 3
	步骤 Step	温度 $^\circ\text{C}$ temperature	时间(分钟) Time (minute)																																	
	1	-55 ± 2	30 ± 3																																	
	2	$+25 \pm 2$	≤ 3																																	
	3	$+125 \pm 2$	30 ± 3																																	
	4	$+25 \pm 2$	≤ 3																																	
步骤 Step	温度 $^\circ\text{C}$ temperature	时间(分钟) Time (minute)																																		
1	-25 ± 2	30 ± 3																																		
2	$+25 \pm 2$	≤ 3																																		
3	$+125 \pm 2$	30 ± 3																																		
4	$+25 \pm 2$	≤ 3																																		
静电容量 变化率 Relative capacitance change	NPO N750 SL	在 $\pm 3\%$ 或 $\pm 0.03\text{PF}$ 以内, 取较大者为准 With in $\pm 3\%$ or $\pm 0.03\text{PF}$, based upon whichever is higher																																		
	B/R	$\pm 10\%$																																		
	E(Y5U)	$\pm 20\%$																																		
	F(Y5V)	$\pm 30\%$																																		
损耗角 正切值 Loss angle tangent value $\text{tg}\delta$	NPO N750 SL	(1) $C < 10\text{pF}$: $\text{tg}\delta \leq 1/200 + 10C$																																		
		(2) $10\text{pF} < C < 30\text{PF}$: $\text{tg}\delta \leq 1/275 + 5C/2$																																		
	(3) 30pF 以上: $\text{tg}\delta \leq 0.0028$																																			
	B/R	$\text{tg}\delta \leq 0.050$																																		
E (Y5U)	$\text{tg}\delta \leq 0.050$																																			
	F (Y5V)	$\text{tg}\delta \leq 0.070$																																		
绝缘电阻 Insulation resistance IR	NPO、N750、SL: $\text{IR} \geq 2500 \text{ M}\Omega$																																			
	B (Y5P)、E(Y5U)、F(Y5V): II类(CT81): $\text{IR} \geq 1000 \text{ M}\Omega$; II类(CT7/CHG): $\text{IR} \geq 3000 \text{ M}\Omega$																																			
耐电压 Voltage- proof (端子间) (between terminations)	参照项目 5 内容 With reference to the project 5 content																																			



圆片瓷介电容器 ceramic disc capacitor

项 目 Item		性 能 Performances		试验方法及条件 Test method	
12、 耐湿性 Resistance to damp heat	外观 Appearance	无显著异状容易辨认 No abnormality and marking shall be easily legible		<p>预处理：在 $125 \pm 2^\circ\text{C}$ 温度下放置 1 小时，在常温下恢复 24 ± 2 小时后测试。Pretreatment: Capacitor shall be stored at $125 \pm 2^\circ\text{C}$ for 1 hour, than placed at room condition for $24 \pm 2^\circ\text{C}$ hour before test.</p> <p>试验温度： $40 \pm 2^\circ\text{C}$ 相对湿度： 90-95%RH 试验时间： $500+24/-0$ 小时 Test temperature: $40 \pm 2^\circ\text{C}$ Relative humidity: 90-95% Test duration: $500+24/-0$h</p> <p>后处理：在室温条件下恢复 24 ± 2 小时后测试。 Post processing: Capacitor shall be stored for 24 ± 2h at room condition, before test.</p>	
	静电容量 变化率 Relative capacitance change	NPO N750 SL DL	在 $\pm 5\%$ 或 $\pm 0.5\text{PF}$ 以内， 取较大者为准 Within $\pm 5\%$ or $\pm 0.5\text{PF}$ based upon whichever is higher		
		B/R	$\pm 10\%$ max		
		E (Y5U)	$\pm 20\%$ max		
		F (Y5V)	$\pm 30\%$ max		
	散逸因数 Tangent of loss angel ($\text{tg } \delta$)	NPO N750 SL DL	(1) $C < 10\text{pF}$: $\text{tg } \delta \leq 1/200 + 10C$ (2) $10\text{pF} < C < 30\text{PF}$: $\text{tg } \delta \leq 1/275 + 5C/2$ (3) 30pF 以上: $\text{tg } \delta \leq 0.0028$		
		B/R	$\text{tg } \delta \leq 0.050$		
		E (Y5U)	$\text{tg } \delta \leq 0.050$		
		F (Y5V)	$\text{tg } \delta \leq 0.070$		
	绝缘电阻 Insulation resistance	NPO、 N750、 SL: $\text{IR} \geq 2500 \text{ M}\Omega$			
B(Y5P)、 E(Y5U)、 F(Y5V): II类(CT81): $\text{IR} \geq 1000 \text{ M}\Omega$					
II类(CT7/CHG): $\text{IR} \geq 3000 \text{ M}\Omega$					
耐电压 (端子间) Voltage-poof (Between terminations)	参照项目 5 内容 With reference to the project 5 content				



圆片瓷介电容器 ceramic disc capacitor

项 目 Item		性 能 Performances		试验方法及条件 Test method	
13、 耐湿负荷 Loading under damp heat	外观 Appearance	无显著异状容易辨认 No abnormality and marking shall be easily legible		预处理：在 125±2℃ 温度下放置 1 小时，在常温下恢复 24±2 小时后测试。 Pretreatment: Capacitor shall be stored at 125±2℃ for 1 hour, than placed at room condition for 24±2℃ hour before test. 试验温度：40±2℃ 相对湿度：90-95%RH 试验时间：500+24/-0 小时 电气的负荷条件：1KVDC 充放电电流：50mA 以下 Test temperature: 40±2℃ Relative humidity: 90-95% Test duration: 500+24/-0h Applied Voltage: 1KVDC 后处理：在室温条件下恢复 24±2 小时后测试。 Post processing: Capacitor shall be stored for 24±2h at room condition, before test.	
	静电容量 变化率 Relative capacitance change	NPO N750 SL DL	在 ±7.5% 或 ±0.75PF 以内, 取较大者为准 Within ±7.5% or ±0.75PF based upon whichever is higher		
		B/R	±10% max		
		E (Y5U)	±20% max		
	散逸因数 Tangent of loss angel (tg δ)	NPO N750 SL	C < 30pF: tg δ ≤ 1/100 + 10×C/3 C ≥ 30pF: tg δ ≤ 0.0028		
		B/R	tg δ ≤ 0.050		
		E (Y5U)	tg δ ≤ 0.050		
		F (Y5V)	tg δ ≤ 0.070		
	绝缘电阻 Insulation resistance	NPO、N750、SL: IR ≥ 2500 MΩ			
		B(Y5P)、R(Y5R)、E(Y5U)、F(Y5V): II类(CT81): IR ≥ 1000 MΩ; II类(CT7/CHG): IR ≥ 3000 MΩ			
耐电压 (端子间) Voltage-poof (Between terminations)	参照项目 5 内容 With reference to the project 5 content				



圆片瓷介电容器 ceramic disc capacitor

项 目 Item	性 能 Performances	试验方法及条件 Test method	
14、高温 负荷 Loading at elated temperature	外观 Appearance	无显著异状容易辨认 No abnormality and marking shall be easily legible	
	静电容量 变化率 Relative capacitance change	NPO N750 SL	在±3%或±0.3PF 以内,取较大者为准 Within ±3% or±0.05PF based upon whichever is higher
		B/R	±10% max
		E	±20% max
		F	±30% max
	散逸因数 Tangent of loss angel (tg δ)	NPO N750 SL	C<10pF: tg δ ≤1/200+C×10 10pF <C<30pF: Tg δ ≤1/275+5×C/2 C>30pF: tg δ ≤0.0028
		B/R	tgδ≤0.050
E (Y5U)		tgδ≤0.050	
绝缘电阻 Insulation resistance	NPO、N750、DL、SL: IR≥4000 MΩ	试验温度 Test temperature: 125±2℃ 试验时间 Test duration: 1000+24/-0h 负荷条件 Electric loading condition: CT81/CC81: U _R ≤5KV: 1.5U _R CT81/CC81: 6KV ≤U _R ≤8KV: U _R +500V CT81/CC81: 10KV ≤U _R : 10KV CT7 (CHG): U _R 充放电流 50mA 以下 Charge/discharge current: 50mA.or less	
	B/R、E(Y5U)、F(Y5V): II类(CT81): IR≥1000 MΩ II类(CT7): IR≥3000 MΩ		
耐电压 (端子间) Voltage-pooof (Between terminations)	参照项目 5 内容 With reference to the project 5 content	后处理: 在室温条件下恢复 24±2 小时后测试。 Post processing: Capacitor shall be stored for 24±2h at room condition, before test.	
15、冷热 冲击试验 Thermal Shock Test	外观 Appearance	无显著异常 No marked defect	
		电容器在-40℃环境中维持 10mins, 3 分钟之内将产品移至 100℃环境中维持 10mins,为一个循环, 共循环 50 次。 Capacitor shall be stored for 10mins at-40℃, In 3minscapacitor shall be Moved to100℃ for 10mins ,as a cycle. circulating for50 times	



圆片瓷介电容器 ceramic disc capacitor

10、产品特性曲线图 product characteristics

10.1 I类电容器温度特性曲线 (CC81)

TC Chart for Class 1 capacitor

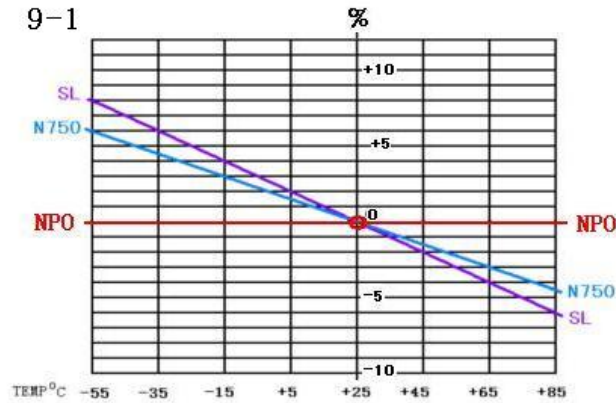

10.2 II类电容器温度特性曲线(CT81\CT7)

TC Chart for Class II capacitor

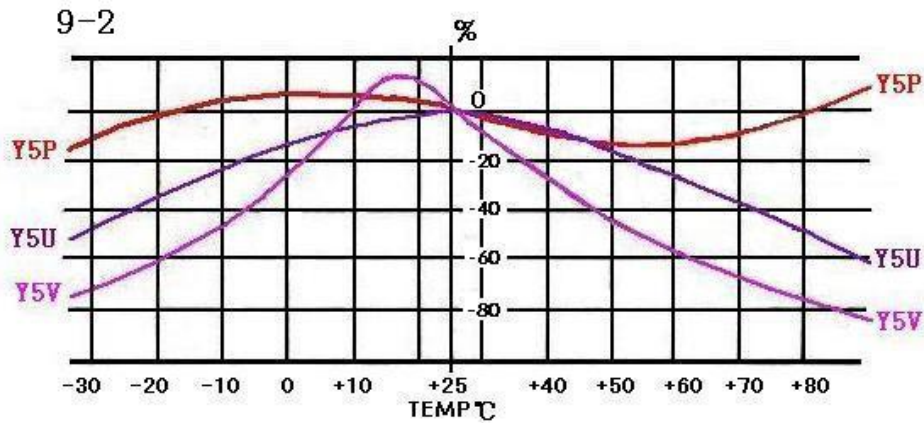

11、包装尺寸及数量 packing size and quantity

项目 Item	包装箱尺寸对应表 Packing size corresponding to the table	
	外箱 out box	内箱 inside box
散装 bulk	46×34.5×28 (cm)	33×22×12.5 (cm)
	46×31.5×23.5 (cm)	30×21.5×10.5 (cm)
	44.5×25.5×22 (cm)	24×21.5×9.5 (cm)
	32.5×27×23.5 (cm)	24×21.5×9.5 (cm)
编带 taping	52.5×28×36 (cm)	34.5×26.5×4.8 (cm)
	52.5×28×34.5 (cm)	33.0×26.5×4.8 (cm)



圆片瓷介电容器 ceramic disc capacitor

项 目 Item	低压产品 low voltage product ($V_t \leq 500V$)	
包装形式 packing form	散装 bulk	编带 taping
片径大小 diameter size	all	
最小包装数量 Minimum packaging quantity	1Kpcs	2Kpcs
内箱产品数量 inside box product quantity	25Kpcs	2Kpcs
外箱产品数量 out box product quantity	100Kpcs	20Kpcs

项 目 Item	高压产品 high voltage product (1KV、2KV、3KV、Y ₁ 、Y ₂)					
	散装 bulk (pcs)		或根据实际情况进行装箱。 Or packing according to actual conditions	编带 taping (Kpcs)		
包装形式 packing form	$\Phi 4 \sim \Phi 9$	$\Phi 10 \leq$		F=5	F=7.5	
	最小包装产品数量 Minimum packaging quantity	1k	0.5k			P0=12.7
			2	$\leq \Phi 9$	$\Phi 10 \leq$	
内箱产品数量 inside box product quantity	10k	5k	2	1.5	1	1
外箱产品数量 out box product quantity	40k	20k	20	15	10	10

12、产品的储存 product's storage

- 1、产品储存场地要整洁、干燥、通风、无漏水、无污染。

Product storage site to clean, dry and ventilated, no leakage, no pollution.

- 2、产品长时间储存时不易直接放在地面，要放在托架上进行防潮。

Products seldom directly on the ground, when stored for a long time to put on the bracket to moistureproof.

- 3、注意按包装箱上的堆放高度对产品进行堆放。

Note based on the stacking height of packing products to pile up.

- 4、储存环境温度：-25℃~+40℃；储存期限：长期（附注：储存期满一年或以上的，在使用前请检测确认容量参数，若检测发现容量偏低，则需对整批次产品进行返烘作业处理，处理后可以正常使用）。

Storage temperature: - 25 °C ~ + 40 °C; Storage life: long-term (note: store expired a year or more, before use, please confirm capacity testing parameters, if the detection capacity is low, the need to return the whole batch products baked job processing, processing can be normal use).



圆片瓷介电容器 ceramic disc capacitor

13、注意事项 (Notes) :

1. 工作电压 Operating voltage:

在交流电路或纹波电流电路中使用直流额定电压电容器时,请务必确保外加电压的 V_{p-p} 值或包含直流偏置电压的 V_{o-p} 值保持在额定电压范围内。若向电路施加电压,开始或停止时可能会因谐振或切换产生暂时的不规则电压,请务必使用额定电压范围大于此不规则电压的电容器。

Be sure to maintain the V_{p-p} value of the applied voltage or the V_{o-p} which contains DC bias within the rated voltage range. When the voltage is started to apply to the circuit or it is stopped applying, the irregular voltage may be generated for a transit period because of resonance or switching. Be sure to use a capacitor within rated voltage containing this irregular voltage.

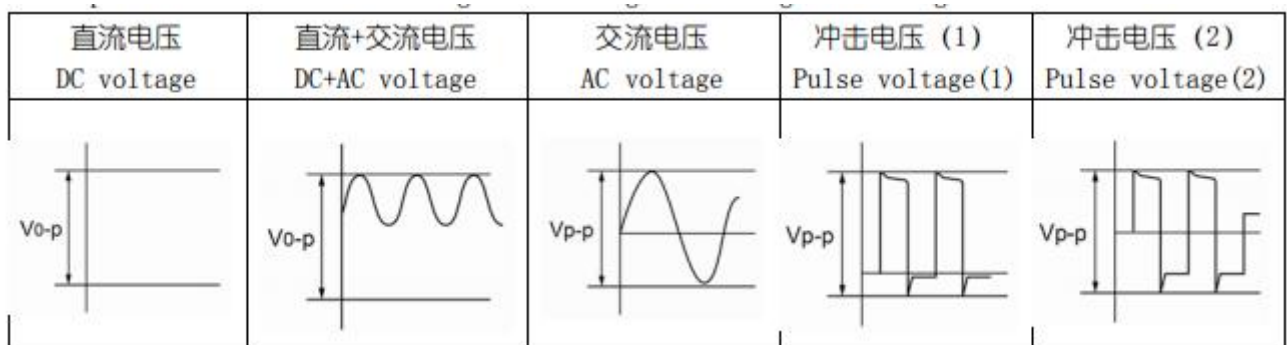

2. 工作温度和自身发热 Operating temperature and self-generated heat:

电容器的表面温度应保持在额定工作温度范围的上限以下,务必考虑到电容器自身发出的热量。电容器在高频电流、冲击电流等中使用可能会因介电损耗自身发热,所施加之正弦波电压的频率应低于 300kHz.外加电压应使自身发热等负荷在 25℃ 周围温度条件下不超过 20℃ 范围,测量时应使用 $\phi 0.1\text{mm}$ 小热容量的 (K) 的热电偶,而且电容器不应受到其它组件的散热或周围温度波动影响。过热可能会导致电容器特性及可靠性下降(切勿在冷却风扇运转时进行测量,否则无法确保测量数据的精确性)。

Keep the surface temperature of a capacitor below the upper limit of its rated operating temperature range. Be sure to take into account the heat generated by the capacitor itself. When the capacitor is used in a high-frequency current, pulse current or the like, it may have the self-generated heat due to dielectric-loss. Applied voltage should be the load such as self-generated heat is within 20℃ on the condition of atmosphere temperature 25℃. When measuring, use a thermocouple of small thermal capacity-K of $\phi 0.1\text{mm}$ and be in the condition where capacitor is not affected by radiant heat of other components and wind of surroundings. Excessive heat may lead to deterioration of the capacitor's characteristics and reliability. (Do not measure when the cooling fan is running, otherwise unable to ensure the accuracy of the measurement data.)

3. 耐电压的测试条件 Test condition for withstanding voltage:

3.1 测试设备 Test equipment:

交流耐电压的测试设备应具有能够产生类似于 50/60Hz 正弦波的功能,如果施加变形的正弦波或超



圆片瓷介电容器 ceramic disc capacitor

过规定电压值的超载电压，则可能会导致故障。

Test equipment for AC withstanding voltage shall be used with the performance of the wave similar to 50/60 Hz sine waves. If the distorted sine wave or over load exceeding the specified voltage value is applied, the defective may be caused.

3.2 电压外加方法 Voltage applied method:

施加耐电压时，电容器的引线或端子应与耐电压测试设备的输出端连接牢固，然后再将电压从近零增加到测试电压。如果测试电压不从近零逐渐提高而是直接施加在电容器上，则施加时应包含过零点

*.测试结束时，测试电压应降到近零，然后再将电容器引线或端子从耐电压测试设备的输出端取下。

如果测试电压不从近零逐渐提高而是直接施加在 电容器上，则可能会出现浪涌电压,从而导致故障。

When the withstanding voltage is applied, capacitor' s lead or terminal shall be firmly connected to the output of the withstanding voltage test equipment, and then the voltage shall be raised from near zero to the test voltage. If the test voltage without the raise from near zero voltage would be applied directly to capacitor, test voltage should be applied with the *zero cross. At the end of the test time, the test voltage shall be reduced to near zero, and then capacitor's lead or terminal shall be taken off the output of the withstanding voltage test equipment. If the test voltage without the raise from near zero voltage would be applied directly to capacitor, the surge voltage may arise, and therefore, the defective may be caused. ZERO CROSS is the point where voltage sine wave pass 0V.- See the right figure.

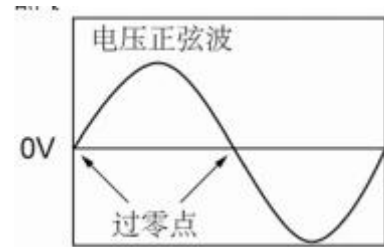

*过零点是指电压正弦通过 0V 的位置。 参见右图：

4. 失效安全性 Fail-Safe:

如果电容器破损，会导致短路电路故障.务必在本产品上适当提供例如保险丝等自动防故障功能，以免导致电击、火灾、或冒烟等。When capacitor would be broken, failure may result in a short circuit. Be sure to provide an appropriate fail-safe function like a fuse on your product if failure would follow an electric shock, fire or fume.

5. 焊接、安装与使用 Soldering 、mounting and use:

5.1 振荡与冲击 Vibration and impact

使用时请勿使电容器或引线受到过度冲击或振荡。

When using do not make the capacitor or lead by excessive impact or vibration.

5.2 焊接 Soldering

将该产品焊接在 PCB/PWB 上时，不应超出电容器的耐焊接热规格，本产品过热会使内部接点锡焊料熔化，导致温度骤变,从而造成陶瓷组件产生裂纹。当使用烙铁焊接电容器时，应遵循以下条件：

烙铁头温度：最高 400℃；烙铁功率：最大 50W；焊接时间：最多 3.5 秒

When soldering this product to a PCB/PWB, do not exceed the solder heat resistance specification of the capacitor. Subjecting this product to excessive heating could melt the internal junction solder, Lead to temperature shock , Resulting in the ceramic element to produce crack. When soldering capacitor with a soldering iron, it should be performed in following conditions: Temperature of iron-tip: 400 degrees C. max.



圆片瓷介电容器 ceramic disc capacitor

Soldering iron wattage: 50W max.

6. 清洗（超声波清洗）Cleaning (ultrasonic cleaning):

进行超声波清洗时,应遵守下列条件：“洗涤槽容量：20 瓦特输出功率 / 每升或以下；洗涤时间：最多 5 分钟；不得直接振荡 PCB/PWB”。过度的超声波洗涤会导致引线的超载损坏。

To perform ultrasonic cleaning, observe the following conditions. Rinse bath capacity: Output of 20 watts per liter or less. Rinsing time: 5 minutes max. Do not vibrate the PCB/PWB directly. Excessive ultrasonic cleaning may lead to fatigue destruction of the lead wires

X-ON Electronics

Largest Supplier of Electrical and Electronic Components

Click to view similar products for [Ceramic Disc Capacitors](#) category:

Click to view products by [Fenghua Advanced](#) manufacturer:

Other Similar products are found below :

[5AU100JCECA](#) [5AU220JCGCA](#) [5AU560JCJCA](#) [DEF2CLH020CA3B](#) [HCU180KBCDRTKR](#) [432202101621](#) [DEF2CLH030CJ3B](#)
[101GHR102K](#) [W1X223MCVCF0KR](#) [CC-100N](#) [564RBA142EH472MA03](#) [NCD102K1KVY5FF](#) [NCD101K1KVY5FF](#) [NCD103M1KVZ5UF](#)
[NCD151K1KVY5FF](#) [NCD331K1KVY5FF](#) [440LT68AP-R](#) [AOL-1502-02](#) [NCD103M1KVZ5UJTBF](#) [DEF2CLH040CN3A](#)
[DEF2CLH080DA3B](#) [0811-040-X7R0-102K](#) [8903D0](#) [90410-10](#) [YV101103Z060HAND5P](#) [SL102101J060BAND5P](#) [ZU501103M090B20C6P](#)
[ZU102103M100X05B0P](#) [YP102271K050B20C6P](#) [YP102391K050BAND5P](#) [YP501101K040BAND5P](#) [ZU102103M100BAND5H](#)
[YP102681K060B20C6P](#) [YP501121K040B20C6P](#) [SL102181J070HAND5P](#) [YP501471K040B20C6P](#) [SL102151J070HAND5P](#)
[YP501102K050HAND5P](#) [ZU501102M050B20C6P](#) [YP501472K100B20C6P](#) [ZU102103M100B20C0P](#) [YV500223Z080HAND5P](#)
[CC1H220KA1EDCH4B1100](#) [SL500330J040B20C2P](#) [SL501510J050B20C6P](#) [SL102221J080HAND5P](#) [YP500103M100HAND5P](#)
[YP102101K050B20C5B](#) [YP500472K070HAND5P](#) [SL102101J060HAND5H](#)