



承 认 书

品名： 圆片陶瓷电容器

ITEM: Ceramic Disc Capacitors

制造 MANUFACTURER			客户 CUSTOMER		
拟制 DESIGN	审核 CHECK	批准 APPROVAL	检验 INSPECTOR	审核 CHECK	批准 APPROVAL
张锦洪	王晨晓	王维			

公司名称：广东风华高新科技股份有限公司正华陶瓷电容器分公司

Company name: Fenghua Advanced Technology (Holding) Co. Ltd
Zhenghua Ceramic Disc Capacitor Branch Company

地 址:广东省肇庆市黄岗东大门工业城 110 号

Address: No.110 Industrial City, Great gate, Eastern Huanggang Zhaoqing city.

电话 (Telephone) :0758-6923812 邮编 (Zip code) :526060



圆片瓷介电容器 ceramic disc capacitor

1、产品介绍 Product introduction

圆片陶介电容器是一种芯片介质主要为钛酸钡，并用烧渗法将金属镀在陶瓷上作为电极制成，有环氧树脂包封和酚醛树脂包封两种，按其介质特性可分为 I 类温度补偿型、II 类高介电常数型；III 类半导体型。

Ceramic disc capacitor is a kind of chip mainly for barium titanate, and burn infiltration method will be made of metal plating on ceramic as the electrode, with epoxy resin and phenolic resin coating, can be divided by its dielectric properties I class type temperature compensation、II class type high dielectric constant、III class type semiconductor.

1.1 产品的特征

产品类型 Product Type	主要特点 main feature
CC1、CC81— I 类温度补偿型 I class Temperature compensation	介电常数小、介电损耗小、介电常数的温度系数的范围很广、容量与温度呈现线性变化。 Small dielectric constant, dielectric loss and the temperature coefficient of dielectric constant range is very wide, capacity and temperature of linear change.
CT1、CT81— II 类高介电常数 II class high dielectric constant	介电常数特别高、介电常数随温度呈非线性变化，介电常数随施加的外电场有非线性关系。 Particularly high dielectric constant and dielectric constant changing with temperature is nonlinear, dielectric constant with the applied electric field has a nonlinear relationship.
CS1— III 类半导体型 III class semiconductor	介电常数很大，所以半导体电容器具有体积小，容量大的特点。 Dielectric constant is very big, so the semiconductor capacitor has small volume, the characteristics of large capacity.
CT7— 交流 alternating current	绝缘性能好、耐压保险系数大，能承受大电流冲击。 Good insulation performance, compression coefficient of insurance, can withstand the large current shock.



圆片瓷介电容器 ceramic disc capacitor

1.2 产品的选型及正确的使用方法

产品类型 Product Type	主要用途 main application
CC1、CC81— I 类温度补偿型 I class Temperature compensation	用于要求损耗值小、容量稳定性要求较高的电路中：谐振回路、高频旁路、温度补偿、控制电路的时间常数元件、稳定性要求高的耦合元件。 Loss value for small and high capacitance stability circuit: the resonant circuit, high-frequency bypass, temperature compensation and control time constant of the circuit components, high stability requirements of coupling components.
CT1、CT81— II 类高介电常数 II class high dielectric constant	用于对损耗值和容量稳定性要求不高的电路中，如低频旁路、耦合、滤波、退耦等，时间常数元件。 Used for loss value and volume stability of circuits, such as low frequency, by-pass, coupling, filtering, decoupling, etc., the time constant of components.
CS1— III 类半导体型 III class semiconductor	适用于在耐压较低的电路中作旁路和耦合、以及应用于宽带信号和频率分离的电路中。 Apply to circuits in the low pressure bypass and coupling, as well as the application in the broadband signal and frequency separation of circuits.
CT7— 交流 alternating current	交流瓷介电容器适于在电子设备中作为跨电源线连接、天线耦合和旁路等 In ac ceramic capacitor is suitable for electronic equipment as the power cord connection and antenna coupling and bypass, etc
备注 note: 要注意产品类别、材质类别、电压级别、容量级别、外形尺寸的选择。 Pay attention to the product category and material category, the choice of voltage level, capacity level, appearance size.	

2、产品注意事项

瓷介电容器的静电容量易受温度影响，由后面的温度特性曲线可知道：I 类产品的容易受温度影响相对偏小，II 类、III 类产品容量受温度影响呈非线性变化，因此进行容量测试前要把产品在国标规定的标准测试条件 $25 \pm 2^\circ\text{C}$ 的环境下放置 2~4 小时后再进行测试。

Ceramic capacitor electrostatic capacity is affected by temperature, the temperature characteristic curve of the back know: I products easily affected by temperature is relatively small, II, III product capacity is affected by the temperature change is nonlinear, so the capacity test before to product the standards prescribed by the national standard test conditions to $25 + 2^\circ\text{C}$ placed under the environment of 2 ~ 4 hours before test.

3、使用温度范围 operating temperature range : $-25^\circ\text{C} \sim +105^\circ\text{C}$

(但规格内规定的使用温度范围为: $-25^\circ\text{C} \sim +85^\circ\text{C}$)

But the operating temperature range specified in the specification: $-25^\circ\text{C} \sim +85^\circ\text{C}$)

4、应用领域 application field

广泛适用于家电、照明、通讯、网络、汽车电子等设备中。

Widely used in household appliances, lighting, communications, networking, automotive electronics and other equipment.



5、型号构成 Part numbers

CC1 — F 5 SL 1 B 101 J S E W
 (1) (2) (3) (4) (5) (6) (7) (8) (9) (10) (11)

- (1) 产品类型 Product Type
- (2) 额定电压及代码 Rated Voltage and the code
- (3) 产品的芯片直径 Chip diameter of product
- (4) 温度特性 Temperature Characteristics (T.C.)
- (5) 引线形式 Lead style
- (6) 引线间距 Lead spacing
- (7) 标称容量 (额定容量) Rated capacitance
- (8) 允许偏差 Capacitance Tolerance
- (9) 包装形式 Packing style
- (10) 包封形式 Coating style
- (11) 无铅 Lead-Free

5.1 产品类型 Product Type

Code	产品类型	Product Type
CC1	低压温度补偿型	Low voltage temperature compensation capacitor
CC81	高压温度补偿型	High voltage temperature compensation capacitor
CT1	低压高介电常数型	Low voltage high dielectric constant disk ceramic capacitor
CT81	高压高介电常数型	High voltage high dielectric constant disk ceramic capacitor
CSI	半导体型电容器	Semiconductor disk ceramic capacitor
CT7	交流电容器	Alternating current disk ceramic capacitor

5.2 额定电压代码 Rated Voltage code

代码 code	额定电压 Rated voltage
D	16VDC
E	25VDC
F	50VDC
H	63 VDC
G	100 VDC
A	200VDC
L	500VDC

代码 code	额定电压 Rated voltage
N	1KVDC
M	2KVDC
P	3KVDC
Q	4KVDC
R	5KVDC
S	6KVDC

代码 code	额定电压 Rated voltage	电压等级 Voltage grade
X	250VAC	Y ₂
Y	400VAC	Y ₁



圆片瓷介电容器 ceramic disc capacitor

5.3 产品的芯片直径代码 Chip diameter of product code

命名方式代码 code	5	10	11	说明
芯片标称直径区间 (mm)	4.5~5.4	9.5~10.4	10.5~11.4	例如,代码“10”,若选的标称尺寸是 9.5mm 的,则实际芯片尺寸范围为:9.25~9.75mm; 若选的标称尺寸是 10.4mm 的,则实际芯片尺寸范围为:10.15~10.65mm
芯片尺寸公差 (mm)	±0.25	±0.25	±0.25	±0.35	±0.35	

5.4 温度特性 T.C. (Temperature Characteristics)

温度特性 Temperature Characteristics		温度范围 Temperature range	容量允许偏差 Cap.change of temp.coeff
Used code	EIA code		
NP0	C0H	-25°C ~ +85°C	0 ± 60 PPM/°C
N750	U2J		750 ± 120 PPM/°C
SL	S2L		+140 ~ -1000 PPM/°C
Y5P	Y5P		± 10%
Y5U	Y5U		+22 / -56%
Y5V	Y5V		+30 / -86%

5.5 引线形式代码 Lead style code

代号 symbol	引线形式 lead style	代号 symbol	引线形式 lead style
1	长直脚(长 16~28mm) Straight long lead (16~28mm)	6	大内弯 Large inside kink
2	短直脚(长 16~20mm) Straight short lead (16~20mm)	7	特殊直脚 Special Straight lead
3	切脚(短脚)Cutting lead(short lead)	9	单外弯 Single Outside kink
4	直脚编带 Straight taping	0	前后翘 Vertical crimp lead
5	小内弯 Small inside kink		

5.6 引线间距代码 Lead spacing code

代码 code	A	B	D	E
引线间距 Lead spacing(mm)	2.5 ± 0.5	5.0 ± 0.5	7.5 ± 0.5	10.0 ± 0.5

5.7 标称容量(额定容量) Rated capacitance

Code	capacitance	注:标称容量以 pF 为单位,用 3 位数字表示。前两位数字表示有效数字,第三位为 0 的个数;R 表示小数点。 Note: The unit of standard capacitance if consisting of 3 digits, 1st two digits stand for effective value of the Standard capacitance; third digit indicates the number of zeros; R indicates decimal.
4R7	4.7pF	
330	33pF	
471	470pF	
103	10000pF	



圆片瓷介电容器 ceramic disc capacitor

5.8 允许偏差 Capacitance Tolerance

代码 code	J	K	M	Z
偏差 Tolerance	±5%	±10%	±20%	+80/-20%

5.9 包装形式 Packing style

代码 Code	T	S
包装形式 packing style	编带包装 Taping	散包装 bulking

5.10 包封形式 Coating style

代码 code	P	E
包装形式 Coating style	酚醛树脂 Phenol resin	环氧树脂 Epoxy resin

5.11 无铅 Lead-Free

6、外形尺寸 shape & size

6.1 长直脚(长 16~28mm) Straight long lead (16~28m)

引线形式代码 Lead style code: **1** Unit: mm

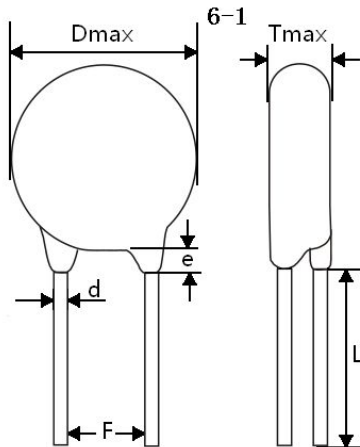

Lead code	1A	1B	1D	1E
F (±0.5)	2.5	5.0	7.5	10.0
L	16Min			
d (±0.05)	0.38、 0.42、 0.50	0.50、 0.60	0.50、 0.60、 0.65	0.60 0.65
e	4.0 Max			



圆片瓷介电容器 ceramic disc capacitor

6.2 短直脚(长 16~20mm) Straight short lead (16~20mm)

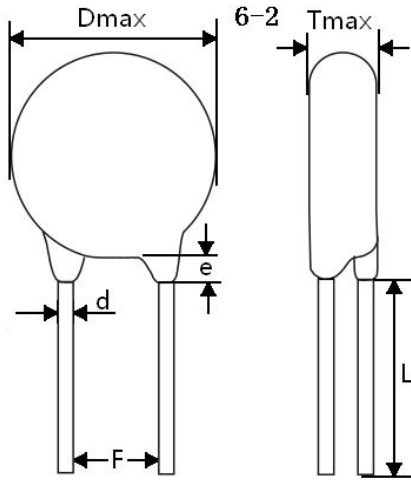

引线形式代码 Lead style code: **2** Unit: mm

Lead code	2A	2B
F (± 0.5)	2.5	5.0
L	16 Min	
d (± 0.05)	0.38、0.42、0.50	
e	2.0 Max	

6.3 切脚(短脚) Cutting lend(short lead)

引线形式代码 Lead style code: **3** Unit: mm

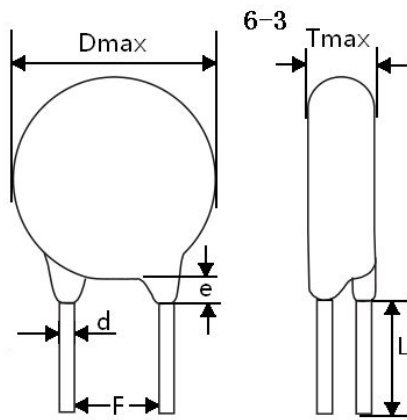

Lead code	3A	3B	3D	3E
F (± 0.5)	2.5	5.0	7.5	10.0
L	3.5 \pm 0.5 or buyer request			
d (± 0.05)	0.38、 0.42、 0.50	0.50、 0.60	0.50、 0.60、 0.65	0.60 0.65
e	2.5 Max			



圆片瓷介电容器 ceramic disc capacitor

6.4 直脚编带 Straight taping

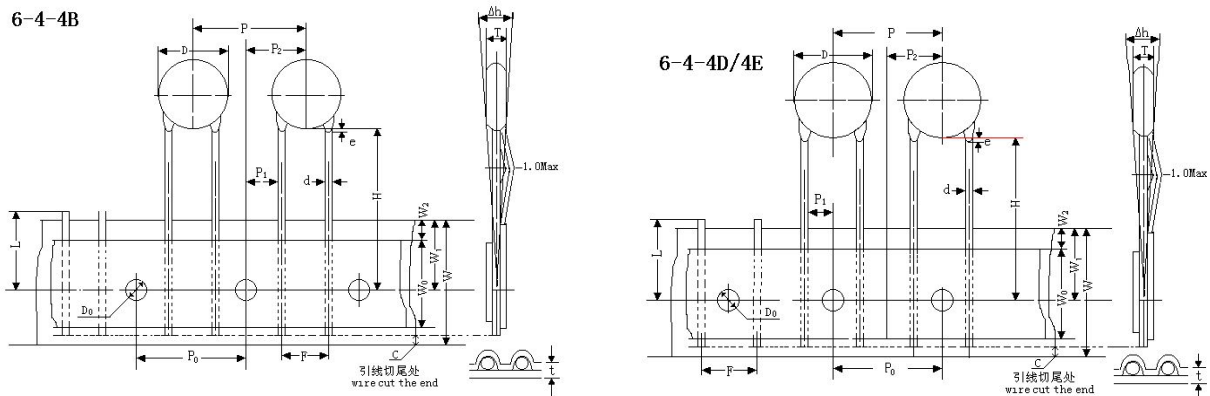

引线形式代码 Lead style code: **4** Unit: mm

序号 No.	符号 Code	引线代码 lead code (4B)	引线代码 Lead code (4D)		引线代码 Lead code (4E)
1	D	≦ 10.0	≦ 10.0	≦ 13.0	≦ 13.0
2	P	12.7	12.7	15.0	15.0
3	P₀	12.7±0.3	12.7±0.3	15.0±0.3	15.0±0.3
4	P₁	3.85±0.7	2.4±0.7	3.4±0.7	2.4±0.7
5	P₂	6.35±1.0	6.35±1.0	7.5±1.0	7.5±1.0
6	F	5.0±0.5	7.5±0.5		10.0±0.5
7	d±0.05	0.50、0.60	0.60、0.65		0.60、0.65
8	e	3.0 Max	3.0 Max		3.0 Max
9	H	20.0±1.0	20.0±1.0		20.0±1.0
10	Δh	2.0 Max	2.0 Max		2.0 Max
11	T	4.0 Max	5.0 Max		6.0 Max
12	D₀	4.0±0.2	4.0±0.2		4.0±0.2
13	W	18.0±0.5	18.0±0.5		18.0±0.5
14	W₀	7.5 Min	9.0 Min		9.0 Min
15	W₁	9.0±0.5	9.0±0.5		9.0±0.5
16	W₂	1.5±1.5	1.5±1.5		1.5±1.5
17	L	11.0 Max	11.0 Max		11.0 Max
18	C	0~5.0	0~5.0		0~5.0
19	t	0.7±0.2	0.7±0.2		0.7±0.2



圆片瓷介电容器 ceramic disc capacitor

6.5 小内弯 Small inside kink

注：小内弯适用于额定电压小于 1KV 的产品。

Small inside kink is suitable for the rated voltage is less than 1 kv products.

6.5.1 小内弯散装 Small inside kink bulk

引线形式代码 Lead style code: **5** Unit: mm

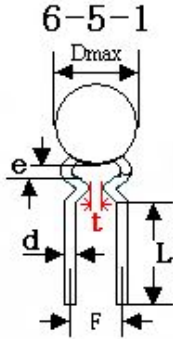

Lead code	5B
F (± 0.5)	5.0
L	16.0 Min or buyer request
d (± 0.05)	0.50、0.60
e	3.0 Max
t	1.5~2.0mm

6.5.2 小内弯编带 Small inside kink taping

引线形式代码 Lead style code: **5** Unit: mm

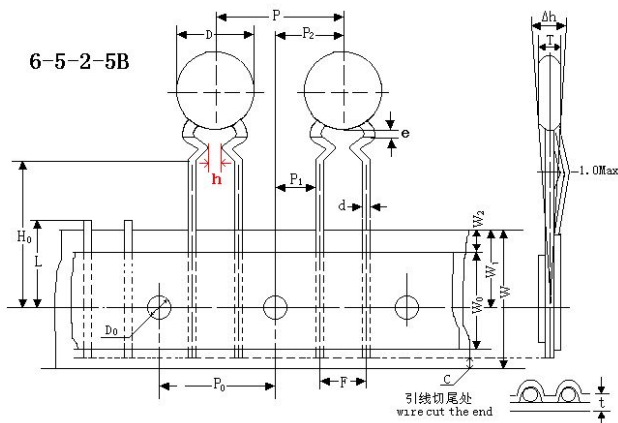

序号 No.	符号 Code	引线代码 lead code (5B)
1	D	≤ 10.0
2	P	12.7
3	P ₀	12.7 \pm 0.3
4	P ₁	3.85 \pm 0.7
5	P ₂	6.35 \pm 1.0
6	F	5.0 \pm 0.5
7	d \pm 0.05	0.50、0.60
8	e	3.0 Max
9	H ₀	16.0+1.5/-1.0mm
10	Δh	2.0 Max
11	T	3.5Max
12	D ₀	4.0 \pm 0.2
13	W	18.0 \pm 0.5
14	W ₀	7.5 Min
15	W ₁	9.0 \pm 0.5
16	W ₂	1.5 \pm 1.5
17	L	11.0 Max
18	C	0~5.0
19	t	0.7 \pm 0.2
20	h	1.5~2.0



圆片瓷介电容器 ceramic disc capacitor

6.6 大内弯 Large inside kink

注：大内弯适用于 1KV、2KV 高压产品。

Large inside kink is suitable for the rated voltage is 1kv and 2kv products.

6.6.1 大内弯散装 Large inside kink bulk

引线形式代码 Lead style code: **6** Unit: mm

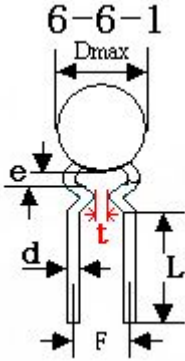

Lead code	6B	6D	6E
F (± 0.5)	5.0	7.5	10.0
L	16.0Min or buyer request		
d (± 0.05)	0.50、0.60、0.65		
e	3.0 Max		
t	2.5 \pm 1.0	5.0 \pm 1.0	6.5 \pm 1.0

6.6.2 大内弯编带 Large inside kink taping

引线形式代码 Lead style code: **6** Unit: mm

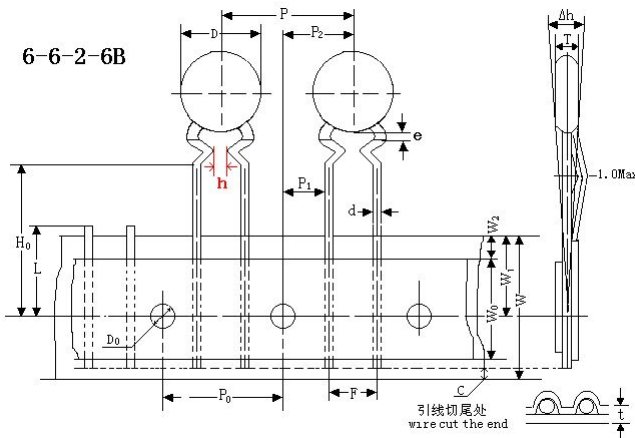

序号 No.	符号 Code	引线代码 lead code (6B)
1	D	≤ 10.0
2	P	12.7
3	P₀	12.7 \pm 0.3
4	P₁	3.85 \pm 0.7
5	P₂	6.35 \pm 1.0
6	F	5.0 \pm 0.5
7	d \pm 0.05	0.50、0.60
8	e	3.0 Max
9	H₀	16.0 + 1.5 / - 1.0 mm
10	Δh	2.0 Max
11	T	4.0 Max
12	D₀	4.0 \pm 0.2
13	W	18.0 \pm 0.5
14	W₀	7.5 Min
15	W₁	9.0 \pm 0.5
16	W₂	1.5 \pm 1.5
17	L	11.0 Max
18	C	0~5.0
19	t	0.7 \pm 0.2
20	h	2.5 \pm 1.5



圆片瓷介电容器 ceramic disc capacitor

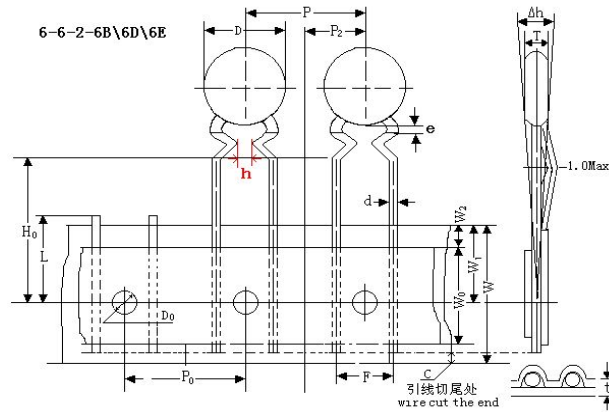

序号 No.	符号 Code	引线代码 lead code (6B)	引线代码 lead code (6D)		引线代码 lead code (6E)
1	D	≦ 13.0	≦ 10.0	≦ 13.0	≦ 10.0
2	P	15.0	12.7	15.0	15.0
3	P₀ ±0.3	15.0	12.7	15.0	15.0
4	P₁ ±0.7	3.4	2.4	3.4	2.4
5	P₂ ±1.0	7.5	6.35	7.5	7.5
6	F ±0.5	5.0	7.5	7.5	10.0
7	e (Max)	4.0	3.0	4.0	4.0
8	T (Max)	5.0	4.0	5.0	6.0
9	d ±0.05	0.50、0.60	0.50、0.60、0.65		0.50、0.60、0.65
10	H₀	16.0+1.5/-1.0mm	16.0+1.5/-1.0mm		16.0+1.5/-1.0mm
11	Δh	2.0 Max	2.0 Max		2.0 Max
12	D₀ ±0.2	4.0	4.0		4.0
13	W ±0.5	18.0	18.0		18.0
14	W₀	7.5 Min	7.5 Min		7.5 Min
15	W₁ ±0.5	9.0	9.0		9.0
16	W₂ ±1.5	1.5	1.5		1.5
17	L	11.0 Max	11.0 Max		11.0 Max
18	C	0~5.0	0~5.0		0~5.0
19	t ±0.2	0.7	0.7		0.7
20	h	2.5±1.0	5.0±1.0		6.5±1.0

6.7 特殊直脚 Special Straight lead

引线形式代码 Lead style code: **7** Unit: mm

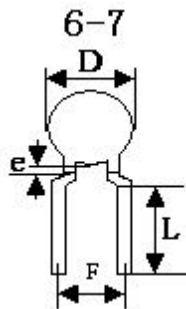

Lead code	7B	7D	7E
F (±0.5)	5.0	7.5	10.0
L	16.0 Min or buyer request		
d (±0.05)	0.50、0.60、0.65		
e	3.0 Max		



圆片瓷介电容器 ceramic disc capacitor

6.8 单外弯 Single Outside kink

6.8.1 单外弯散装 Single Outside kink bulk

引线形式代码 Lead style code: **9** Unit: mm

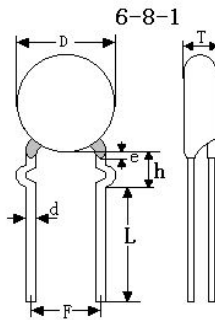

Lead code	9B	9D	9E
F (± 0.5)	5.0	7.5	10.0
h Max	5.0	5.0	6.0
L	16.0Min or buyer request		
d (± 0.05)	0.50、0.60、0.65		
e	3.0 Max		

6.8.2 单外弯编带 Single Outside kink taping

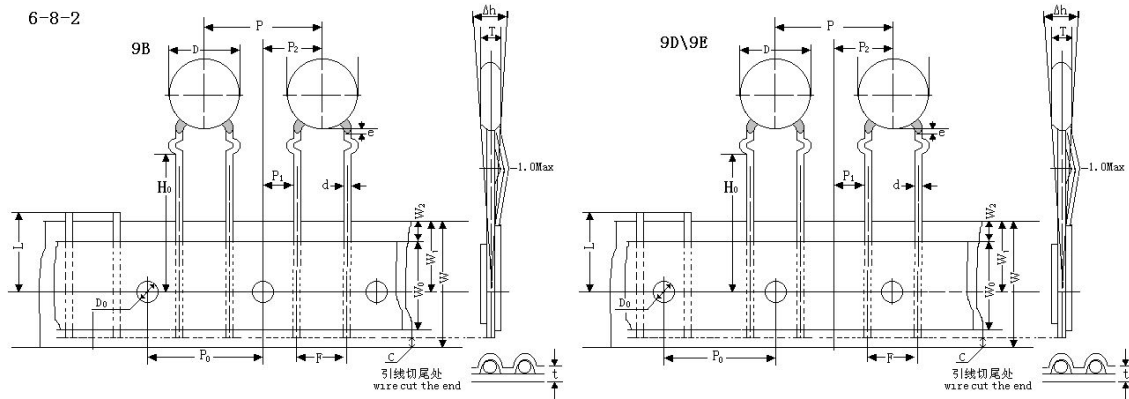

序号 No.	符号 Code	引线代码 lead code (9B)		引线代码 lead code (9D)	引线代码 lead code (9E)
1	D	≤ 10.0	≤ 13.0	≤ 13.0	≤ 13.0
2	P	12.7	15.0	15.0	15.0
3	P₀ ± 0.3	12.7	15.0	15.0	15.0
4	P₁ ± 0.7	3.85	3.4	3.4	2.4
5	P₂ ± 1.0	7.5	7.5	7.5	7.5
6	F ± 0.5	5.0	5.0	7.5	10.0
7	e (Max)	4.0	4.0	4.0	4.0
8	T (Max)	5.0	5.0	5.0	6.0
9	d ± 0.05	0.50、0.60		0.50、0.60、0.65	
10	H₀	16.0+1.5/-1.0mm	16.0+1.5/-1.0mm	16.0+1.5/-1.0mm	16.0+1.5/-1.0mm
11	Δh	2.0 Max	2.0 Max	2.0 Max	2.0 Max
12	D₀ ± 0.2	4.0	4.0	4.0	4.0
13	W ± 0.5	18.0	18.0	18.0	18.0
14	W₀	7.5 Min	7.5 Min	7.5 Min	7.5 Min
15	W₁ ± 0.5	9.0	9.0	9.0	9.0
16	W₂ ± 1.5	1.5	1.5	1.5	1.5
17	L	11.0 Max	11.0 Max	11.0 Max	11.0 Max
18	C	0~5.0	0~5.0	0~5.0	3.5
19	t ± 0.2	0.7	0.7	0.7	0.7
20	h	2.5\pm1.0	5.0\pm1.0	6.5\pm1.0	6.5\pm1.0



圆片瓷介电容器 ceramic disc capacitor

6.9 前后翘 Vertical crimp lead

6.9.1 前后翘散装 Vertical crimp lead bulk

引线形式代码 Lead style code: **0** Unit: mm

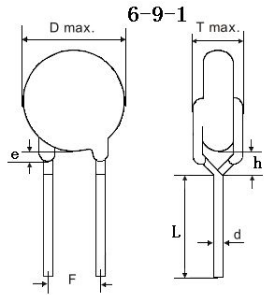

Lead code	0B	0D	0E
F (± 0.5)	5.0	7.5	10.0
h	4.0 Max		
L	16.0Min or buyer request		
d (± 0.05)	0.50、0.60、0.65		
e	3.0 Max		

6.9.2 前后翘编带 Vertical crimp lead taping

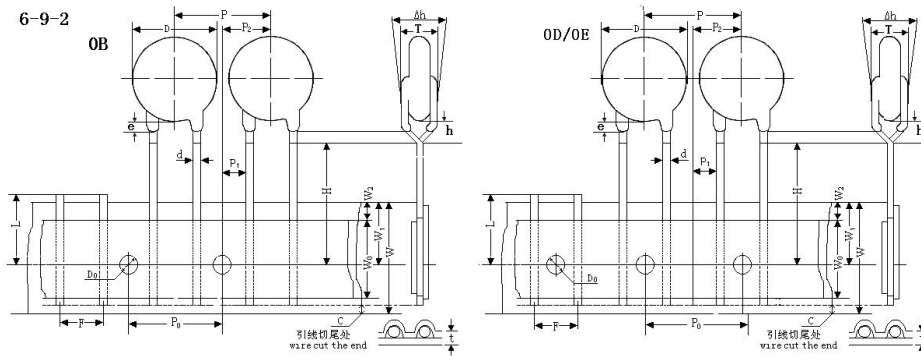

序号 No.	符号 Code	引线代码 lead code		引线代码 Lead code	
		(0B)	(0D)	(0D)	(0E)
1	D	≤ 10.0	≤ 10.0	≤ 13.0	≤ 13.0
2	P	12.7	12.7	15.0	15.0
3	P₀	12.7 ± 0.3	12.7 ± 0.3	15.0 ± 0.3	15.0 ± 0.3
4	P₁	3.85 ± 0.7	2.4 ± 0.7	3.4 ± 0.7	2.4 ± 0.7
5	P₂	6.35 ± 1.0	6.35 ± 1.0	7.5 ± 1.0	7.5 ± 1.0
6	F	5.0 ± 0.5	7.5 ± 0.5		10.0 ± 0.5
7	d ± 0.05	0.50、0.60	0.60、0.65		0.60、0.65
8	e	3.0 Max	3.0 Max		3.0 Max
9	H	$16.0+1.5/-1.0\text{mm}$	$16.0+1.5/-1.0\text{mm}$		$16.0+1.5/-1.0\text{mm}$
10	Δh	2.0 Max	2.0 Max		2.0 Max
11	T	4.0 Max	5.0 Max		6.0 Max
12	D₀	4.0 ± 0.2	4.0 ± 0.2		4.0 ± 0.2
13	W	18.0 ± 0.5	18.0 ± 0.5		18.0 ± 0.5
14	W₀	7.5 Min	9.0 Min		9.0 Min
15	W₁	9.0 ± 0.5	9.0 ± 0.5		9.0 ± 0.5
16	W₂	1.5 ± 1.5	1.5 ± 1.5		1.5 ± 1.5
17	L	11.0 Max	11.0 Max		11.0 Max
18	C	0~5.0	0~5.0		0~5.0
19	t	0.7 ± 0.2	0.7 ± 0.2		0.7 ± 0.2
20	h	4.0Max	4.0Max		4.0Max



圆片瓷介电容器 ceramic disc capacitor

7、产品额定值 Product rated parameters

(温度特性、额定电压、标称容量、容量偏差、引线间距、本体直径、本体厚度)

T.C. 、Rated voltage、Rated capacitance、Capacitance Tolerance、Lead spacing、

BodyDiameter、BodyThickness

产品类型 Product Type	温度 特性 T.C.	额定电压 Rated voltage (V)	标称容量 Rated capacitance (pF)	允许偏差 Capacitance Tolerance (%)	引线间距 Lead spacing (mm)	本体直径 Body diameter (mm)	本体厚度 Body thickness (mm)
CC1	NPO N750	50V (F) 63V (H) 100V (G) 200V (A) 500V (L)	10~56	±5% (J) ±10%(K)	5.0	6.0 Max	3.0Max
		68~100	7.0Max				
	SL	50V (F) 63V (H) 100V (G) 200V (A) 500V (L)	68~221	±5% (J) ±10%(K)	5.0	6.0 Max	3.0Max
CC81	NPO N750	1KV(N)	10~30	±10%(K) ±20%(M)	5.0、7.5	6.0 Max	3.5Max
			33~56			7.0Max	
		2KV(M)	10~15		5.0、7.5 、10.0	6.0 Max	4.0Max
			18~47			7.0Max	
		3KV(P)	10~15		7.5、10.0	6.0 Max	5.0Max
			18~47			7.0Max	
	SL	1KV(N)	18~47	±10%(K) ±20%(M)	5.0、7.5	6.0 Max	3.5Max
			56~151			7.0Max	
		2KV(M)	18~47		5.0、7.5 、10.0	6.0 Max	4.0Max
			56~151			7.0Max	
		3KV(P)	18~47		7.5、10.0	6.0 Max	5.0Max
			56~151			7.0Max	
产品类型 Product Type	温度 特性 T.C.	额定电压 Rated voltage (V)	标称容量 Rated capacitance (pF)	允许偏差 Capacitance Tolerance (%)	引线间距 Lead spacing (mm)	本体直径 Body diameter (mm)	本体厚度 Body thickness (mm)
CS1	Y5P	50VDC	103	±10%(K)	5.0	6.0 Max	3.0Max
	Y5V	25VDC 50VDC	223	±20%(M) +80/-20%(Z)	5.0	6.0 Max	
			473		5.0	6.0 Max	
			104		5.0	7.0Max	



圆片瓷介电容器 ceramic disc capacitor

产品类型 Product Type	温度 特性 T.C.	额定电压 Rated voltage(V)	标称容量 Rated capacitance(pF)	允许偏差 Capacitance Tolerance(%)	引线间距 Lead spacing(mm)	本体直径 Body diameter(mm)	本体厚度 Body thickness(mm)	
CT1	Y5P	50V (F)	101~222	±10%(K)	5.0	6.0 Max	3.0Max	
	Y5V	63V (H)	102~472	±20%(M) +80/-20%(Z)	5.0	6.0 Max		
		100V (G) 200V (A)	562~103			6.0 Max		
	Y5P	500V (L)	101~102	±10%(K)	5.0	6.0 Max		
			122、152			7.0 Max		
			182			8.0 Max		
			222、332			9.0 Max		
			392、472			11.0 Max		
			103			15.0 Max		
	Y5V	500V (L)	102~332	±20%(M) +80/-20%(Z)	5.0	6.0 Max		
			472~682			7.0 Max		
			103			9.0 Max		
	产品类型 Product Type	温度 特性 T.C.	额定电压 Rated voltage(V)	标称容量 Rated capacitance(pF)	允许偏差 Capacitance Tolerance(%)	引线间距 Lead spacing(mm)		本体直径 Body diameter(mm)
CT81	Y5P	1KV(N)	101~561	±10%(K) ±20%(M)	5.0 or 7.5 or 10.0	6.5 Max	3.5Max	
			681~122			7.5Max		
			152			8.5Max		
			182 272			95Max		
			332 392			10.5Max		
			472 682			13.5Max		
			103			15.5Max		
		2KV(M)	101~391	±10%(K) ±20%(M)	5.0 or 7.5 or 10.0	6.5 Max		4.0Max
			471、561			7.5Max		
			821~122			8.5Max		
			152			95Max		
			182、222			10.5Max		
			332、392			11.5Max		
			472			15.5Max		
	3KV(P)	101~331	±10%(K) ±20%(M)	7.5 or 10.0	6.5 Max	5.0Max		
		391~561			7.5Max			
		681~102			8.5Max			
		102~152			95Max			
		182、222			10.5Max			



圆片瓷介电容器 ceramic disc capacitor

产品类型 Product Type	温度 特性 T.C.	额定电压 Rated voltage(V)	标称容量 Rated capacitance(pF)	允许偏差 Capacitance Tolerance(%)	引线间距 Lead spacing(mm)	本体直径 Body diameter(mm)	本体厚度 Body thickness(mm)	
CT81	Y5U	1KV(N)	331~102	±20%(M)	5.0 or 7.5 or 10.0	6.5 Max	3.5Max	
			102~182			7.5Max		
			222			8.5Max		
			332、392			9.5Max		
			472			10.5Max		
			103			11.5Max		
		2KV(M)	331~821	±20%(M)	5.0 or 7.5 or 10.0	6.5 Max	4.0Max	
			102~152			7.5Max		
			182~252			8.5Max		
			272、332			9.5Max		
			392、472			10.5Max		
			103			13.5Max		
		3KV(P)	331~821	±20%(M)	7.5 or 10.0	6.5 Max	5.0Max	
			102~152			7.5Max		
			182~222			8.5Max		
			252、272			9.5Max		
			332、392			10.5Max		
			472			11.5Max		
	103	13.5Max						
	CT81	Y5V	1KV(N)	102~152	±20%(M) +80/-20%(Z)	5.0 or 7.5 or 10.0	6.5 Max	3.5Max
				182~272			7.5Max	
332~562				8.5Max				
682~822				9.5Max				
822~103				10.5Max				
2KV(M)			102	±20%(M) +80/-20%(Z)	5.0 or 7.5 or 10.0	6.5 Max	4.0Max	
			102~222			7.5Max		
			252~332			8.5Max		
			392~472			9.5Max		
			682			10.5Max		
			103			13.5Max		
3KV(P)			102~222	±20%(M) +80/-20%(Z)	7.5 or 10.0	7.5Max	5.0Max	
			222~332			8.5Max		
			332、392			9.5Max		
			472、562			10.5Max		
			682、822			11.5Max		
			103			13.5Max		



圆片瓷介电容器 ceramic disc capacitor

产品类型 Product Type	温度特性 T.C.	额定电压 Rated voltage(V)	标称容量 Rated capacitance(pF)	允许偏差 Capacitance Tolerance(%)	引线间距 Lead spacing(mm)	本体直径 Body diameter(mm)	本体厚度 Body thickness(mm)
CT7	Y5P	250VAC (X)	101~331	±10%(K) ±20%(M)	7.5 or 10.0	6.5 Max	5.0Max
			331~561			7.5Max	
			681、821			8.5Max	
			821~102			9.5Max	
			102~152			10.5Max	
	Y5U	250VAC (X)	331~102	±10%(K) ±20%(M)	7.5 or 10.0	6.5 Max	5.0Max
			102~152			7.5Max	
			152~222			8.5Max	
			222~272			9.5Max	
			272~332			10.5Max	
			332~392			11.5Max	
	472~562	13.5Max					
	Y5V	250VAC (X)	102~152	±20%(M) +80/-20%(Z)	7.5 or 10.0	6.5 Max	5.0Max
			102~222			7.5Max	
			222~332			8.5Max	
			332~472			9.5Max	
			472~562			10.5Max	
			103			13.5Max	
产品类型 Product Type	温度特性 T.C.	额定电压 Rated voltage(V)	标称容量 Rated capacitance(pF)	允许偏差 Capacitance Tolerance(%)	引线间距 Lead spacing(mm)	本体直径 Body diameter(mm)	本体厚度 Body thickness(mm)
CT7	Y5P	400VAC (Y)	102~152	±10%(K) ±20%(M)	7.5 or 10.0	6.5 Max	6.0Max
			182~272			7.5Max	
			332~562			8.5Max	
			682~822			9.5Max	
			822~103			10.5Max	
	Y5U	400VAC (Y)	102	±10%(K) ±20%(M)	7.5 or 10.0	6.5 Max	6.0Max
			102~222			7.5Max	
			252~332			8.5Max	
			392~472			9.5Max	
			682			10.5Max	
			103			13.5Max	
	Y5V	400VAC (Y)	102~222	±20%(M) +80/-20%(Z)	7.5 or 10.0	7.5Max	6.0Max
			222~332			8.5Max	
			332、392			9.5Max	
			472、562			10.5Max	
			682、822			11.5Max	
			103			13.5Max	



圆片瓷介电容器 ceramic disc capacitor

8、可靠性测试方法 Specification and test method

项 目 Item	性 能 Performances			试验方法及条件 Test method		
1、外观构造及尺寸 appearance and dimension	外观无异常、构造及尺寸依图示规定 No damage in appearance and dimension accord with fixed			目视检验尺寸以游标卡尺测量 Venire caliper		
2、静电容量 Capacitance	规定之容许误差以内 Within specified tolerance			测试频率和测试电压 Measuring frequency & Measuring voltage:		
3、损耗角正切值 Loss angle Tangent value Tg δ (散逸因数 Dissipation Factor)	CC1 CC81	NPO N750 SL	≤0.0015	1、CC1、CC81: 1 ± 0.1MHz, 1.0 Vrms		
	CT1 CT81	Y5P Y5U	≤0.025 ≤0.030	2、CT1、CT81、CT7: 1 ± 0.1KHz, 1.0Vrms		
	CT7	Y5V	≤0.035	3、CS1: 1 ± 0.1KHz, 0.1 Vrms		
	CS1	U _R =16VDC, tg δ ≤ 0.075		测试温度 Measuring temperature: 25 ± 2°C		
		U _R =25~100VDC, tg δ ≤ 0.050				
4、绝缘电阻 (端子间.) Insulation resistance (I.R) Between lead wire	CC1	≥ 10000M Ω		测试电压 Test voltage	U _R	施加时间 Application time: 60 ± 5S
	CC81	≥ 10000M Ω			500VDC	
	CT1	≥ 4000M Ω			U _R	
	CT81	≥ 10000 M Ω			500VDC	
	CS1	U _R ≤ 16V: I. R ≥ 250 M Ω U _R ≥ 16V: I. R ≥ 1000 M Ω			U _R	
	CT7	≥ 10000M Ω			500VDC	



圆片瓷介电容器 ceramic disc capacitor

项 目 Item		性 能 Performances		试验方法及条件 Test method															
5、耐电压 Voltage- Proof	端子间 Between terminations	无不良 No bed result		测试电压 Test voltage	CC1、CT1 2.5 U _R														
					CC81、CT81 1.5U _R +500V														
					施加时间 Application time	逐批检验 Lot by lot inspection: 5S													
						鉴定和周期检验 Identification and periodic Inspection: 60S													
		充放电电流 Charge/discharge current : ≤50mA																	
	端子与 外装间 Between terminations and enclosure	无不良 No bed result		金属小球法 Small metallic ball method is used															
				测试电压 Test voltage	CC1、CT1 2.5 U _R														
	CC81、CT81 1.5U _R +500V																		
	CS1 1.5U _R																		
CT7 10 U _R																			
		施加时间 Application time : 60S 充放电电流 Charging/discharging current: ≤50mA																	
6、 温度特性 Temperature Characteristics	未施加电压 Without voltage application	在允许规格范围内 <Within specified tolerance>		依次按以下温度循环阶段测定 According to the following in temperature cycle phase measurement															
	施加额定 电压 Rated voltage applied	NPO	在 ± 3% 或 ± 0.03PF 以内, 取较大者为准 Within ± 3% or ±0.03PF, based upon whichever is higher	<table border="1"> <thead> <tr> <th>阶段 Step</th> <th>温度(°C)Temperature</th> </tr> </thead> <tbody> <tr> <td>1</td> <td>25±2°C</td> </tr> <tr> <td rowspan="2">2</td> <td>NPO\N750\SL -55°C</td> </tr> <tr> <td>Y5P\Y5U\Y5V -25°C</td> </tr> <tr> <td>3</td> <td>25±2°C</td> </tr> <tr> <td rowspan="2">4</td> <td>NPO\N750\SL +125°C</td> </tr> <tr> <td>Y5P\Y5U\Y5V +85°C</td> </tr> <tr> <td>5</td> <td>25±2°C</td> </tr> </tbody> </table>		阶段 Step	温度(°C)Temperature	1	25±2°C	2	NPO\N750\SL -55°C	Y5P\Y5U\Y5V -25°C	3	25±2°C	4	NPO\N750\SL +125°C	Y5P\Y5U\Y5V +85°C	5	25±2°C
		阶段 Step				温度(°C)Temperature													
		1				25±2°C													
		2	NPO\N750\SL -55°C																
			Y5P\Y5U\Y5V -25°C																
		3	25±2°C																
4	NPO\N750\SL +125°C																		
	Y5P\Y5U\Y5V +85°C																		
5	25±2°C																		
N750																			
SL																			
B (Y5P)	+10/-15%																		
E (Y5U)	+20/-60%																		
F (Y5V)	+30/-80%																		



圆片瓷介电容器 ceramic disc capacitor

项 目 Item		性 能 Performances	试验方法及条件 Test method								
7、 端子强度 Robustness Of Termination	抗拉强度 Tensile strength	引线不断裂， 电容器不破损 No abnormalities such as breaking or loosening of termination	电容器轴方向加重量 <Apply the tension in the direction of emergence of termination>								
			线径(mm) Wire diameter	拉力(Kg) Tensile force	持续时间(s) time of duration						
			0.31~0.5	0.5kgf	10±1						
			0.5~0.8	1.0kgf							
	弯曲强度 Bending strength	引线不断裂， 电容器不破损 No abnormalities such as breaking or loosening of termination	导线垂直方向加重向下，本体向左 90° 弯曲 试验 2 次。 Apply the tension in the direction of vertical and bend it for 90° , after reset, bend it for 90° in reverse direction twice								
			线径 (mm) Wire diameter	拉力(Kg) Tensile force							
0.31~0.5			0.25								
8、耐振性 Vibration-Re sistance	外观 Appearance	无显著异常 并且容易判断出来 No remarkable abnormality and marking shall be easily legible	频率依次为：10Hz→55Hz→10Hz 振幅：0.75mm，持续时间：60S。 Frequency is as follows: 10Hz→55Hz→10Hz Amplitude: 0.75 mm length of time: 60 S 在 X、Y、Z 三个互相垂直的方向各振动 2 小时，产品无破损、开裂等不良现象。 In the X, Y, Z three mutually perpendicular direction the vibration 2 hours, the products without damage, cracking and other unhealthy phenomenon.								
	静电容量 Capacitance	规格之容许差以内 Within specified tolerance									
	损耗角 正切值 Loss angle tangent value tgδ	满足项目 5 的要求 To satisfy Number 5									
9、可焊性 Solder ability		引线表面均匀沾锡，上锡 面积不小于总面积的 75% Lead uniformly on the surface of tin, tin area of not less than 75% of the total area.	<table border="1"> <tr> <td>焊锡温度 Soldering Temperature</td> <td>235±5℃</td> </tr> <tr> <td>浸入时间 Dipping Time</td> <td>2.0±0.5S</td> </tr> <tr> <td>上锡面积 Tin area</td> <td>≥75%</td> </tr> </table> <p>浸入深度:距离电容本体 2.0±0.5mm Immersion depth : Distance capacitance body 2.5±0.5mm</p>			焊锡温度 Soldering Temperature	235±5℃	浸入时间 Dipping Time	2.0±0.5S	上锡面积 Tin area	≥75%
焊锡温度 Soldering Temperature	235±5℃										
浸入时间 Dipping Time	2.0±0.5S										
上锡面积 Tin area	≥75%										



圆片瓷介电容器 ceramic disc capacitor

项 目 Item		性 能 Performances		试验方法及条件 Test method									
10、 耐焊接热 Welding heat resistant ability	外观 Appearance	无显著异常并且容易判断出来 No remark able abnormality and marking shall be easily legible		预处理：初次测试电容应在 $85 \pm 2^\circ\text{C}$ 环境下放置 1 小时，然后在室温下放置 24 ± 2 小时后测试。 Pre-treatment: Capacitor shall be stored at $85 \pm 2^\circ\text{C}$ for 1 h, then placed at *room condition for 24 ± 2 h before initial measurements.									
	静电容量 变化率 Relative capacitance change	NPO	在 $\pm 2.5\%$ 或 $\pm 0.25\text{PF}$ 以内，取较大者为准 Within $\pm 2.5\%$ or $\pm 0.25\text{PF}$, based upon whichever is higher		<table border="1"> <tr> <td>焊接温度 Soldering Temperature</td> <td>350 $\pm 10^\circ\text{C}$</td> <td>260 $\pm 5^\circ\text{C}$</td> </tr> <tr> <td>焊接时间 Dipping Time</td> <td>3.5 $\pm 0.5\text{sec}$</td> <td>10 $\pm 1\text{ sec}$</td> </tr> </table>			焊接温度 Soldering Temperature	350 $\pm 10^\circ\text{C}$	260 $\pm 5^\circ\text{C}$	焊接时间 Dipping Time	3.5 $\pm 0.5\text{sec}$	10 $\pm 1\text{ sec}$
		焊接温度 Soldering Temperature			350 $\pm 10^\circ\text{C}$	260 $\pm 5^\circ\text{C}$							
		焊接时间 Dipping Time			3.5 $\pm 0.5\text{sec}$	10 $\pm 1\text{ sec}$							
		N750	浸入深度：引线部分有 1.5~2.0mm 在锡面以上。 Immersion depth: Lead part 1.5~2.0mm in the solder side above.										
		SL											
	B (Y5P)	$\leq \pm 10\%$											
E (Y5U)	$\leq \pm 15\%$												
F (Y5V)	$\leq \pm 20\%$												
耐电压 Voltage-proof (端子间) (between terminations)	参照项目 5 内容 With reference to the project 5 content		后处理：电容器应当在室温下放置 1~2 小时。 Post-treatment: Capacitor shall be stored for 1 to 2 h at *room condition.										



圆片瓷介电容器 ceramic disc capacitor

项 目 Item		性 能 Performances		试验方法及条件 Test method																																
11、 温度循环 Temperature cycle	外观 Appearance	无显著异常并且容易判断出来 No remark able abnormality and marking shall be easily legible		1、预处理：在 $85 \pm 2^\circ\text{C}$ 温度下放置 1 小时，在常温下恢复 24 ± 2 小时后测试。 Pre-treatment: Capacitor shall be stored at $85 + 2^\circ\text{C}$ for 1 hour, than placed at room condition for 24 ± 2 h before measurements.																																
	静电容量变化率 Relative capacitance change	NPO N750 SL	在 $\pm 3\%$ 或 $\pm 0.03\text{PF}$ 以内, 取较大者为准 With in $\pm 3\%$ or $\pm 0.03\text{PF}$, based upon whichever is higher		2、按下列步骤循环 5 次： The capacitance measurement shall be made at each step specified in Table, The capacitor shall be subjected to 5 temperature cycles. a、CC1、CC81(NPO、N750、SL)																															
		B (Y5P)	$\leq \pm 10\%$																																	
		E (Y5U)	$\leq \pm 20\%$																																	
	损耗角正切值 Loss angle tangent value $\text{tg}\delta$	NPO N750 SL	(1) $C < 10\text{pF}$: $\text{tg}\delta \leq 1/200 + 10C$		<table border="1" style="margin-bottom: 10px;"> <thead> <tr> <th>步骤 Step</th> <th>温度$^\circ\text{C}$ temperature</th> <th>时间(分钟) Time (minute)</th> </tr> </thead> <tbody> <tr> <td>1</td> <td>-55 ± 2</td> <td>30 ± 3</td> </tr> <tr> <td>2</td> <td>$+25 \pm 2$</td> <td>≤ 3</td> </tr> <tr> <td>3</td> <td>$+125 \pm 2$</td> <td>30 ± 3</td> </tr> <tr> <td>4</td> <td>$+25 \pm 2$</td> <td>≤ 3</td> </tr> </tbody> </table> b、CT1、CT81、CT7(Y5P、Y5U、Y5V) <table border="1" style="margin-top: 10px;"> <thead> <tr> <th>步骤 Step</th> <th>温度$^\circ\text{C}$ temperature</th> <th>时间(分钟) Time (minute)</th> </tr> </thead> <tbody> <tr> <td>1</td> <td>-25 ± 2</td> <td>30 ± 3</td> </tr> <tr> <td>2</td> <td>$+25 \pm 2$</td> <td>≤ 3</td> </tr> <tr> <td>3</td> <td>$+85 \pm 2$</td> <td>30 ± 3</td> </tr> <tr> <td>4</td> <td>$+25 \pm 2$</td> <td>≤ 3</td> </tr> </tbody> </table>		步骤 Step	温度 $^\circ\text{C}$ temperature	时间(分钟) Time (minute)	1	-55 ± 2	30 ± 3	2	$+25 \pm 2$	≤ 3	3	$+125 \pm 2$	30 ± 3	4	$+25 \pm 2$	≤ 3	步骤 Step	温度 $^\circ\text{C}$ temperature	时间(分钟) Time (minute)	1	-25 ± 2	30 ± 3	2	$+25 \pm 2$	≤ 3	3	$+85 \pm 2$	30 ± 3	4	$+25 \pm 2$	≤ 3
			步骤 Step	温度 $^\circ\text{C}$ temperature			时间(分钟) Time (minute)																													
			1	-55 ± 2			30 ± 3																													
		2	$+25 \pm 2$	≤ 3																																
		3	$+125 \pm 2$	30 ± 3																																
		4	$+25 \pm 2$	≤ 3																																
步骤 Step	温度 $^\circ\text{C}$ temperature	时间(分钟) Time (minute)																																		
1	-25 ± 2	30 ± 3																																		
2	$+25 \pm 2$	≤ 3																																		
3	$+85 \pm 2$	30 ± 3																																		
4	$+25 \pm 2$	≤ 3																																		
(2) $10\text{pF} < C < 30\text{PF}$: $\text{tg}\delta \leq 1/275 + 5C/2$																																				
(3) 30pF 以上: $\text{tg}\delta \leq 0.0028$																																				
B (Y5P)	II类	$\text{tg}\delta \leq 0.050$																																		
	III类	$\text{tg}\delta \leq 0.070$																																		
E (Y5U)	II类	$\text{tg}\delta \leq 0.050$																																		
	III类	$\text{tg}\delta \leq 0.070$																																		
F (Y5V)	II类	$\text{tg}\delta \leq 0.070$																																		
	III类	$\text{tg}\delta \leq 0.10$																																		
绝缘电阻 Insulation resistance IR	NPO、N750、SL: $\text{IR} \geq 2500 \text{ M}\Omega$																																			
	B(Y5P)、E(Y5U)、F(Y5V): II类(CT1\CT81), $\text{IR} \geq 1000 \text{ M}\Omega$; II类(CT7), $\text{IR} \geq 3000 \text{ M}\Omega$																																			
	B(Y5P)、E(Y5U)、F(Y5V): III类, $\text{IR} \geq 500 \text{ M}\Omega$ 。																																			
耐电压 Voltage-proof (端子间) (between terminations)	参照项目 5 内容 With reference to the project 5 content		3、后处理：在室温条件下恢复 24 ± 2 小时。 Post-treatment : Capacitor shall be stored for 24 ± 2 h at room condition.																																	



圆片瓷介电容器 ceramic disc capacitor

项 目 Item		性 能 Performances		试验方法及条件 Test method	
12、耐湿性 Resistance to damp heat	外观 Appearance	无显著异状容易辨认 No abnormality and marking shall be easily legible		试验温度：40±2℃ 相对湿度：90-95%RH 试验时间：500+24/-0 小时 取出置常温下 1-2 小时后测定之 Test temperature: 40±2℃ Relative humidity: 90-95% Test duration: 500+24/-0h Take out the specimen from the chamber and allow it to stand under the standard conditions for 1 to 2h	
	静电容量 变化率 Relative capacitance change	NPO N750 SL	在±5%或±0.5PF 以内, 取较大者为准 Within ±5% or ±0.5PF based upon whichever is higher		
		B (Y5P)	±10% max		
		E (Y5U)	±20% max		
		F (Y5V)	±30% max		
	散逸因数 Tangent of loss angel (tg δ)	NPO N750 SL	(1)C<10pF: tg δ ≤ 1/200+10C		
			(2)10pF<C<30PF: tg δ ≤ 1/275+5C/2		
			(3)30pF 以上: tg δ ≤ 0.0028		
		B (Y5P)	II类		tgδ≤0.050
			III类		tgδ≤0.070
E (Y5U)		II类	tgδ≤0.050		
		III类	tgδ≤0.070		
F (Y5V)		II类	tgδ≤0.070		
	III类	tgδ≤0.10			
绝缘电阻 Insulation resistance	NPO、 N750、 SL: IR≥2500 MΩ				
	B(Y5P)、 E(Y5U)、 F(Y5V): II类(CT1\CT81), IR≥1000 MΩ; II类(CT7), IR≥3000 MΩ				
	B(Y5P)、 E(Y5U)、 F(Y5V): III类, IR≥500 MΩ。				
耐电压 (端子间) Voltage-poof (Between terminations)	参照项目 5 内容 With reference to the project 5 content				



圆片瓷介电容器 ceramic disc capacitor

项 目 Item		性 能 Performances		试验方法及条件 Test method	
13、 耐湿负荷 Loading under damp heat	外观 Appearance	无显著异状容易辨认 No abnormality and marking shall be easily legible		试验温度：40±2℃ 相对湿度：90-95%RH 试验时间：500+24/-0 小时 电气的负荷条件：印加额定电压 充放电电流：50mA 以下 Test temperature:40±2℃ Relative humidity: 90-95% Test duration: 500+24/-0h Electric loading condition: Apply rated voltage Recovery: Take out the specimen from the chamber and allow it to stand under the standard conditions for 1 to 2h	
	静电容量 变化率 Relative capacitance change	NPO N750 SL	在±7.5%或±0.75PF 以内, 取较大者为准 Within ±7.5% or ±0.75PF based upon whichever is higher		
		B (Y5P)	±10% max		
		E (Y5U)	±20% max		
	散逸因数 Tangent of loss angel (tg δ)	NPO N750 SL	C<30pF: tg δ ≤1/100+ 10×C/3 C≥30pF: tg δ ≤0.0028		
			B (Y5P)		II类
		E (Y5U)	III类		tgδ≤0.070
			II类		tgδ≤0.050
		F (Y5V)	III类		tgδ≤0.070
			II类		tgδ≤0.070
绝缘电阻 Insulation resistance	NPO、 N750、 SL: IR≥2500 MΩ				
	B(Y5P)、 E(Y5U)、 F(Y5V): II类 (CT1\CT81), IR≥1000 MΩ; II类 (CT7), IR≥3000 MΩ				
	B(Y5P)、 E(Y5U)、 F(Y5V): III类, IR≥500 MΩ。				
耐电压 (端子间) Voltage-poof (Between terminations)	参照项目 5 内容 With reference to the project 5 content				



圆片瓷介电容器 ceramic disc capacitor

项 目 Item		性 能 Performances		试验方法及条件 Test method	
14 、高温 负荷 Loading at elated temperature	外观 Appearance	无显著异状容易辨认 No abnormality and marking shall be easily legible		试验温度：125±2℃	
	静电容量 变化率 Relative capacitance change	NPO N750 SL	在±3%或±0.3PF 以内,取较大者为准 Within ±3% or±0.05PF based upon whichever is higher		试验时间：1000+48/-0 小时 负荷条件：额定电压×200% 充放电流 50mA 以下
		B	±10% max		Test temperature: 125±2℃
		E	±20% max		Test duration: 1000+48/-0h
		F	±30% max		Electric loading condition:
	散逸因数 Tangent of loss angel (tg δ)	NPO N750 SL	C<10pF: tg δ ≤1/200+C×10 10pF <C<30pF: Tg δ ≤1/275+5×C/2 C>30pF: tg δ ≤0.0028		Apply rated voltage×200% Charge/discharge current: 50mA.or less
			B (Y5P)	II类	tgδ≤0.050
			III类	tgδ≤0.070	
		E (Y5U)	II类	tgδ≤0.050	
			III类	tgδ≤0.070	
F (Y5V)		II类	tgδ≤0.070		
	III类	tgδ≤0.10			
绝缘电阻 Insulation resistance	NPO、N750、SL: IR≥4000 MΩ				
	B(Y5P)、E(Y5U)、F(Y5V): II类(CT1\CT81), IR≥1000 MΩ; II类(CT7), IR≥3000 MΩ				
	B(Y5P)、E(Y5U)、F(Y5V): III类, IR≥500 MΩ				
耐电压 (端子间) Voltage-pooof (Between terminations)	参照项目 5 内容 With reference to the project 5 content				



9、产品特性曲线图 product characteristics

9.1 I类电容器温度特性曲线 (CC1\CC81)

TC Chart for Class 1 capacitor

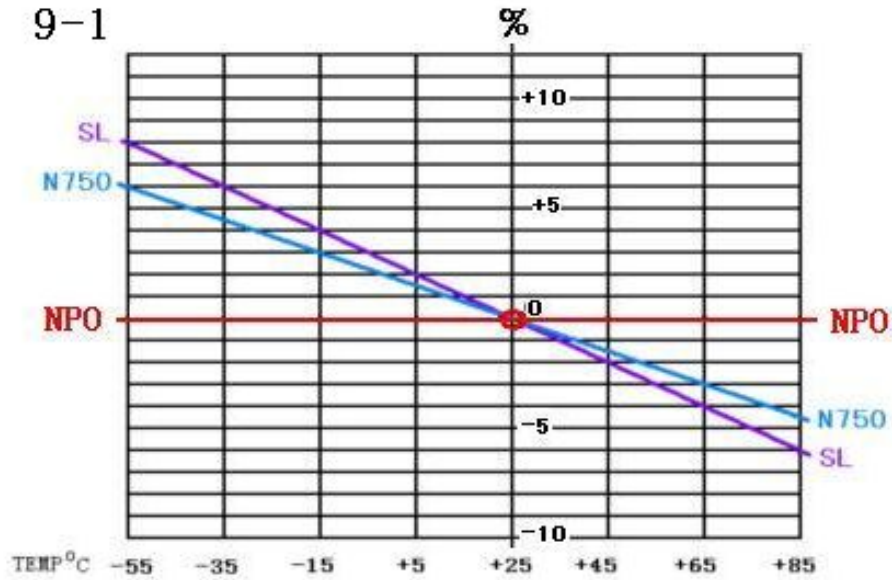

9.2 II类电容器温度特性曲线(CT1\CT81\CT7)

TC Chart for Class II capacitor

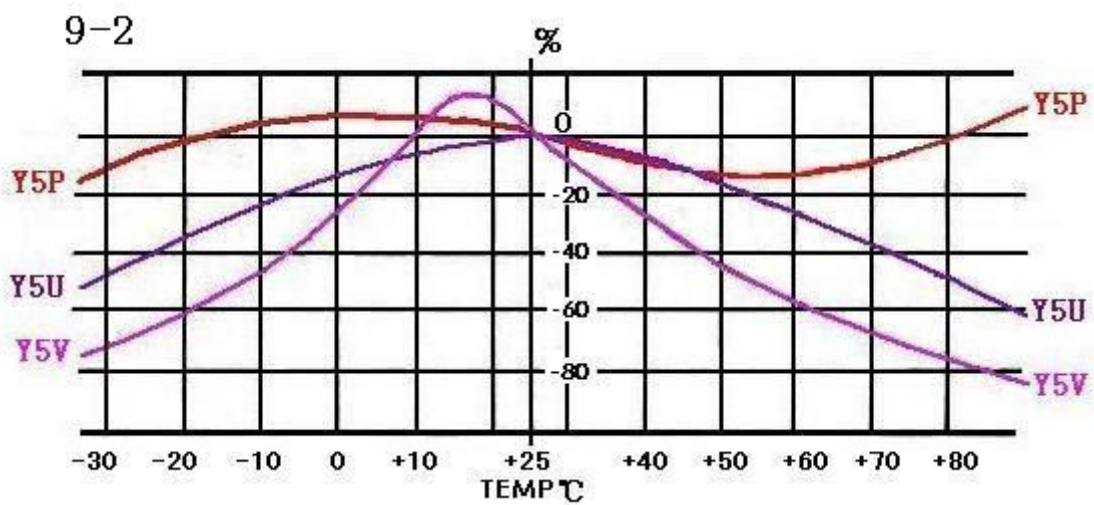



9.3 III类电容器温度特性曲线(CS1)

TC Chart for Class II capacitor

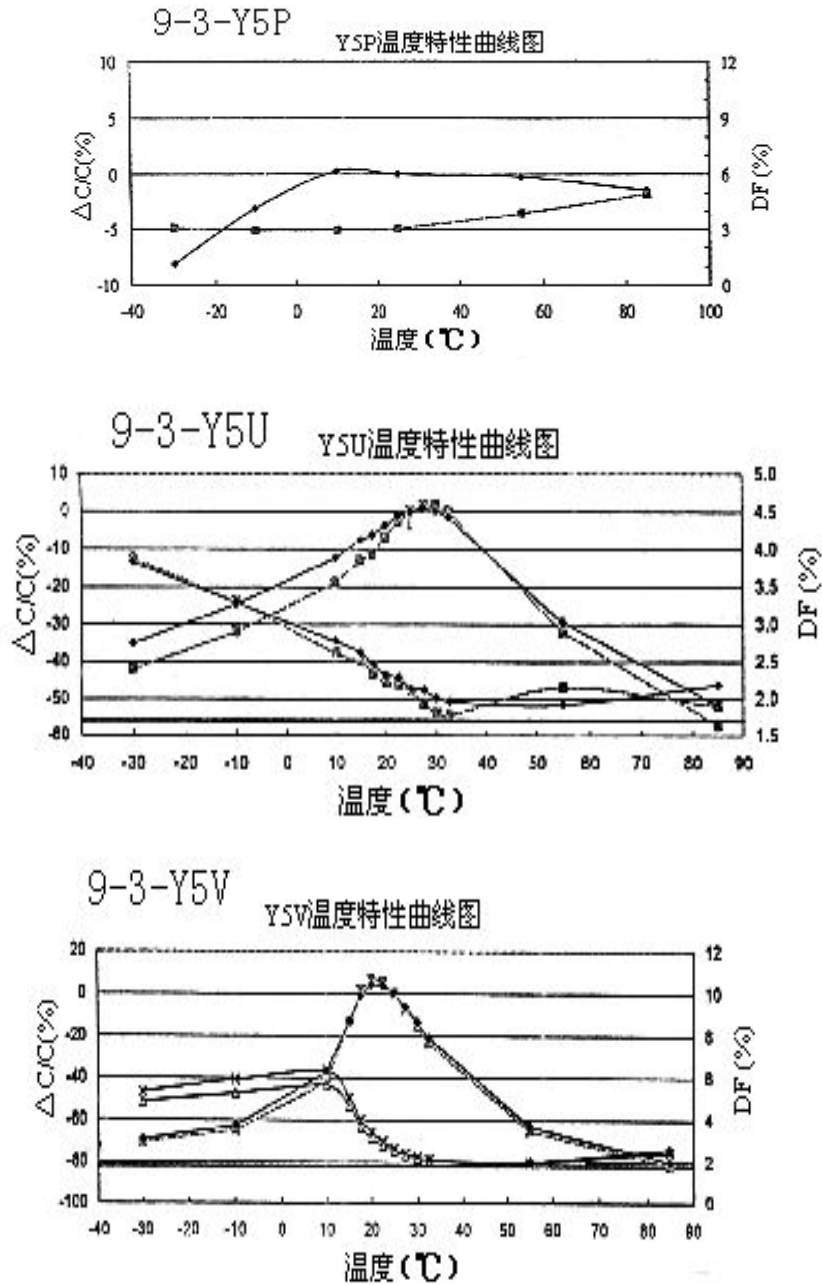

10、产品通过的认证 products through the certification

交流产品获得了 VDE、UL、CQC 认证。

alternating current products have obtained VDE, UL, CQC certification.



11、包装尺寸及数量 packing size and quantity

项目 Item	包装箱尺寸对应表 Packing size corresponding to the table	
	外箱 out box	内箱 inside box
散装 bulk	46×34.5×28 (cm)	33×22×12.5 (cm)
	46×31.5×23.5 (cm)	30×21.5×10.5 (cm)
	44.5×25.5×22 (cm)	24×21.5×9.5 (cm)
	32.5×27×23.5 (cm)	24×21.5×9.5 (cm)
编带 taping	52.5×28×36 (cm)	34.5×26.5×4.8 (cm)
	52.5×28×34.5 (cm)	33.0×26.5×4.8 (cm)

项 目 Item	低压产品 low voltage product ($V_t \leq 500V$)	
包装形式 packing form	散装 bulk	编带 taping
片径大小 diameter size	all	
最小包装数量 Minimum packaging quantity	1kPCS	2Kpcs
内箱产品数量 inside box product quantity	25KPCS	2Kpcs
外箱产品数量 out box product quantity	100kPCS	20Kpcs

项 目 Item	高压产品 high voltage product (1KV、2KV、3KV、Y ₁ 、Y ₂)					
包装形式 packing form	散装 bulk			编带 taping		
	Φ5~Φ9	Φ14 以下	或根据实际情况进行装箱。 Or packing according to actual conditions.	F=5.0	F=7.5	F=10.0
最小包装产品数量 Minimum packaging quantity	1kPCS	0.5kPCS		2Kpcs	1.5KPCS	1KPCS
内箱产品数量 inside box product quantity	10kPCS	5kPCS		2Kpcs	1.5KPCS	1KPCS
外箱产品数量 out box product quantity	40kPCS	20kPCS		20Kpcs	15KPCS	10KPCS

12、产品的储存 product 's storage

- 1、产品储存场地要整洁、干燥、通风、无漏水、无污染。

Product storage site to clean, dry and ventilated, no leakage, no pollution.

- 2、产品长时间储存时不易直接放在地面，要放在托架上进行防潮。

Products seldom directly on the ground, when stored for a long time to put on the bracket to moistureproof.

- 3、注意按包装箱上的堆放高度对产品进行堆放。

Note based on the stacking height of packing products to pile up.

X-ON Electronics

Largest Supplier of Electrical and Electronic Components

Click to view similar products for [Ceramic Disc Capacitors](#) category:

Click to view products by [Fenghua Advanced](#) manufacturer:

Other Similar products are found below :

[009377XM](#) [5AS560JCFCA](#) [5AU100JCECA](#) [5AU470JCJCA](#) [DEF2CLH020CA3B](#) [HSE102MAQBF0KR](#) [432202101621](#) [432202282431](#)
[DEF2CLH030CJ3B](#) [W1X223MCVCF0KR](#) [564RC0GBA302EJ470K](#) [5AS270JCDCA](#) [5AS330JCDCA](#) [5AU330JCGCA](#)
[DE1E3KX222MJ4BN01F](#) [440LT68AP-R](#) [JN222MQ47FAAAAKPLP](#) [H8000090-245](#) [H8000090-225RY](#) [H8000090-309RY](#) [H8000090-](#)
[291RY](#) [F471K39S3NR63K7R](#) [DEF2CLH040CN3A](#) [DEF2CLH080DA3B](#) [564R3DF0T22](#) [CC2150KY5P1KVB5LS-LF](#)
[CC2180KY5P1KVB5LS-LF](#) [CC2470KY5P1KVB5LS-LF](#) [CC2820KY5P1KVB5LS-LF](#) [0838-040-X7R0-220K](#) [JN102MQ35FAAAAKPLP](#)
[0841-040-X5U0-103M](#) [CCH-6K8-5/1000V](#) [140-50N2-101J-TB-RC](#) [ECK-DGL102ME](#) [562R5GAD47RR](#) [S103K75Y5PN8BT0R](#)
[615R100GAD10](#) [615R150GAD10](#) [NCD100K1KVSLF](#) [NCD682M1KVZ5UF](#) [CCK-100N](#) [CCK-100P](#) [CCK-22N](#) [CCK-2N2](#) [CCK-47N](#) [CCK-](#)
[47P](#) [CCK-4N7](#) [CCK-4P7](#) [CK45-B3FD681KYNNA](#)