

■ NTC熱敏電阻器 NTC THERMISTORS

● 概述

這是一種負溫度系數電阻器，其阻值隨環境溫度的升高而降低，這種熱敏電阻是由2種或4種鐵，鎳，鈷，錳或銅的金屬氧化物經過成型并在高溫(1100℃至1300℃)下燒結而制得。

● NTC熱敏電阻的主要技術參數

* 零功率電阻值 R_t

在規定溫度下，采用引起電阻變化相對於總的測量誤差來說可以忽略不計的測量功率測得電阻值。

* 額定零功率電阻值 R_{25}

熱敏電阻器的設計電阻值，通常是指25℃時測得的零功率電阻值并標志在熱敏電阻器上面。

* B值

B值是負溫度系數熱敏電阻器的熱敏指數，它被定義為兩個溫度下零功率電阻值的自然對數之差與這兩個溫度倒數之差的比值，即：

$$B = \ln \frac{R_{T_1}}{R_{T_2}} / \left(\frac{1}{T_1} - \frac{1}{T_2} \right) = \frac{T_1 T_2}{T_2 - T_1} \ln \frac{R_{T_1}}{R_{T_2}}$$

式中： R_{T_1} —溫度為 T_1 時的零功率電阻值

R_{T_2} —溫度為 T_2 時的零功率電阻值

除非特別指出，B值是由25℃(298.15K)和85℃(358.15K)的零功率電阻值計算而得到的，B值在工作溫度範圍內並不是一個嚴格的常數。

* 零功率電阻溫度系數 α_T

指在規定溫度下，熱敏電阻器的零功率電阻隨溫度的變化率與它的零功率電阻之比，即：

$$\alpha_T = \frac{1}{R_T} \frac{DR_T}{DT} = - \frac{B}{T^2}$$

式中： α_T —溫度為 T 時的零功率電阻溫度系數

R_T —溫度為 T 時的零功率電阻

T —溫度(以K表示)

B —B值

OUTLINE

This is a Negative Temperature Coefficient Resistor Whose resistance changes with ambient temperature changes. Thermistor comprises 2 or 4 kinds of metal oxides of iron, nickel, cobalt, manganese and copper, being shaped and Sintered at high temperature(1100℃ to 1300℃)

Critical Technical Parameters of NTC Thermistor

R_t ---Zero Power Resistance

It's a resistance which is got at a fixed temperature on a basis of a testing power which causes resistance to Vary in a range which can be ignored in relation to the total testing error.

R_{25} ---Rated Zero Power Resistance

The design resistance of the thermistor usually refers to the resistance value got at Zero-power at 25℃, which is usually indicated on the thermistor.

B Value

B value stands for the thermal exponent at a negative temperature coefficient. It's defined as a ratio of the balance between the natural logarithms of resistance values at zero-power to the balance between the reciprocals of the two temperatures. The formula is as below:

$$B = \ln \frac{R_{T_1}}{R_{T_2}} / \left(\frac{1}{T_1} - \frac{1}{T_2} \right) = \frac{T_1 T_2}{T_2 - T_1} \ln \frac{R_{T_1}}{R_{T_2}}$$

In this formula: R_{T_1} is the resistance at Zero-power when the temperature is T_1

R_{T_2} is the resistance at Zero-power when the temperature is T_2 Unless otherwise specified, B value is got by calculating the Zero-power resistances at 25℃ (298.15K) and 85℃ (358.15K). It's not a firm constant within the range of working temperature.

Resistance-to-Temperature Coefficient at Zero-power

It refers to the ratio of changes of a thermistor. Resistance value at Zero-power when The temperature, to the resistance value at Zero-power The formula is as below:

$$\alpha_T = \frac{1}{R_T} \frac{DR_T}{DT} = - \frac{B}{T^2}$$

In this formula, "α" stands for the resistance-temperature coefficient at Zero-power when the temperature is T:

R_T stands for the resistance value at Zero-power when the temperature is T

T stands for the temperature(in K)

B stands for B value

* 最大穩態電流 I_{max}

在環境溫度為25℃時允許施加在熱敏電阻器上的最大連續電流。

Max. steady state current I_{max}

The maximum allowable continuous current passing through thermistor at 25°C.

* 耗散系數 δ

在規定的環境溫度下，熱敏電阻器耗散功率變化與其相應溫度變化之比，即： $\delta = \Delta P / \Delta T$ ，在工作溫度範圍內， δ 隨環境溫度變化而有所變化。

Dissipation Coefficient δ

It's the ratio of the changes with a thermistor dissipation power, in a pre-set ambient temperature, to the changes with the temperature. The formula is as below: $\delta = \Delta P / \Delta T$, δ changes in response when the ambient temperature changes, within the ranges of the working temperature.

* 熱時間常數 τ

在零功率條件下，當溫度發生突變時，熱敏電阻體溫度變化了始末兩個溫度差的63.2%所需的時間。 τ 與熱敏電阻器的熱容量C成正比，與其耗散系數 δ 成反比，即： $\tau = C / \delta$

Thermal Time Constant τ

At Zero-power and when a mutation occurs with the temperature, the time "t", which is spent for finishing 63.2% of the gap between the beginning temperature and the ending temperature in the thermistor. is directly proportional to "c", the heat capacity of the thermistor, and is inversely proportional to δ , the dissipation constant. That is " $\tau = C / \delta$ ".

■ 應用範圍

適用於轉換電源、開關電源、UPS 電源、各類電加熱器、電子節能燈、電子鎮流器、各種電子裝置電源電路的保護以及彩色顯示管、白熾燈及其它照明燈具的燈絲保護。

APPLICATIONS

Conversion power supply, switch power, UPS power, Kinds of electric heater, electronic energy-saving lamps, electronic ballast etc all kinds of power circuit protection of electronic equipments, filament protection of CRT, bulb and other lighting lamps.

■ 抑制浪涌電流負溫度系數(NTC)熱敏電阻器

NTC Thermistors For Inrush Current Limiting

● 特性

- * 體積小、功率大、抑制浪涌電流能力强
- * 反應速度快
- * B值大，殘余電阻小、壽命長、可靠性高、系列全，工作範圍寬。

FEATURES

Small in size, high-powered, and very capable of bringing down the surge current;
Quick in reaction;
High in B value and low in residual current;
Long service life and high reliability;
High coefficient of safety and wide range of application.

● 產品型號 PRODUCT MODEL

- * 中性型號的表示方法 Neutral Model Representation Methodl :

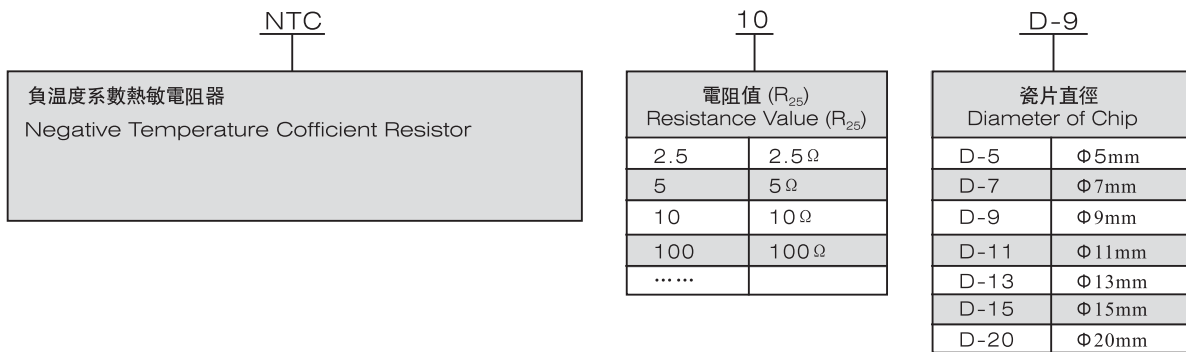

- * 帶公司商標的型號表示方法 Model Representation With Company Logo :

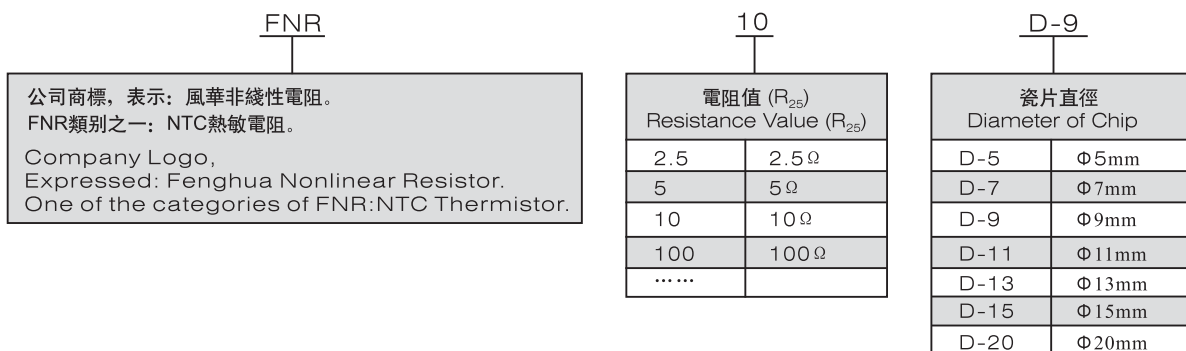

注：“NTC □D-□”與“FNR □D-□”兩者對應的型號其性能參數是一樣的，只是型號識別不同。

如：“NTC 10D-9”與“FNR 10D-9”性能參數是一樣的。

Note: The corresponding models of "NTC □D-□" and "FNR □D-□" have the same performance parameters, Only model recognition is different.
Example: "NTC 10D-9" and "FNR 10D-9", The performance parameters are the same.

• 訂貨方式 HOW TO ORDER

* 中性型號的訂貨方式 HOW TO ORDER Neutral Model :

NTC	100	D09	M	F	2	E	3	S000	B	N	N
(1)	(2)	(3)	(4)	(5)	(6)	(7)	(8)	(9)	(10)	(11)	(12)

(1) NTC: 負溫度系數熱敏電阻器 Negative Temperature Coefficient Resistor

(2) 電阻值(R_{25}) Resistance Value(R_{25}):

代碼 Code	2R5	5R0	100	101
電阻值(R_{25}) Resistance Value	2.5 Ω	5.0 Ω	$10 \times 10^0 = 10 \Omega$	$10 \times 10^1 = 100 \Omega$

(3) 瓷片直徑 Diameter of Chip:

代碼 Code	D05	D07	D09	D11	D13	D15	D20
瓷片直徑 Diameter of Chip	$\Phi 5\text{mm}$	$\Phi 7\text{mm}$	$\Phi 9\text{mm}$	$\Phi 11\text{mm}$	$\Phi 13\text{mm}$	$\Phi 15\text{mm}$	$\Phi 20\text{mm}$

(4) 電阻值公差 Tolerance:

代碼 Code	K	L	M
電阻值公差 Tolerance	$\pm 10\%$	$\pm 15\%$	$\pm 20\%$

(5) 腳型 Lead Style:

代碼 Code	A	B	C	F	H	L
腳型 Lead Style	直腳 Straight Lead	外彎 Outside Kink	Y腳 Y Type	內彎 Inside Kink	側彎 Side Kink	窄口彎 Narrow Mouthed

代碼 Code	Y	T	D
腳型 Lead Style	窄口彎+Y腳 Narrow Mouthed & Y Type	直腳+90° 彎 Straight Lead & 90° Kink	外彎+Y腳 Outside Kink & Y Type

(6) 腳距 Lead Spacing:

代碼 Code	1	2	3	4
腳距 Lead Spacing	5.0mm	7.5mm	10mm	4mm

NTC熱敏電阻器 NTC THERMISTORS

(7) 引腳材質 Lead Material:

代碼 Code	E	U
引腳材質 Lead Material	鍍錫銅包鋼綫 Tin copper clad steel lead wire	鍍錫銅綫 Tin plated copper wire

(8) 引腳直徑 Lead Diameter:

代碼 Code	1	2	3	4	7
引腳直徑 Lead Diameter	Φ0.5mm	Φ0.6mm	Φ0.8mm	Φ1.0mm	Φ0.75mm

(9) 包裝方式/引腳長度/編帶H₀值 Packing Method & Lead Length & The "H₀" value of the tape:

代碼 Code	S000	C030 C035	H160 H190
包裝方式/引腳長度/ 編帶H ₀ 值 Packing Method & Lead Length & The "H ₀ " value of the tape	散裝/長腳 Bulk/Long Lead	散裝/剪短腳 Bulk/Cut Lead C030=3.0mm C035=3.5mm	編帶 Tape H160: H ₀ =16mm H190: H ₀ =19mm

(10) 塗層顏色 Color:

代碼 Code	B	G
塗層顏色 Color	黑色 Black	綠色 Green

(11) N: 內部控制碼 Internal control code

代碼 Code	2	3
內部控制碼 Internal control code	透明護套 Lucency Jacket	黑色護套 Black jacket

(12) N: 內部控制碼 Internal control code

* 帶公司商標型號的訂貨方式 HOW TO ORDER Model With Company Logo :

FNR	100	D09	M	F	2	E	3	S000	B	N	N
(1)	(2)	(3)	(4)	(5)	(6)	(7)	(8)	(9)	(10)	(11)	(12)

(1) FNR: 公司商標, 表示: 風華非綫性電阻 Company Logo, Expressed: Fenghua Nonlinear Resistor.
FNR類別之一: NTC熱敏電阻 One of the categories of FNR: NTC Thermistor.

(2)~(12): 與上面相同 Same as above.

• 外形圖 Outline Fig

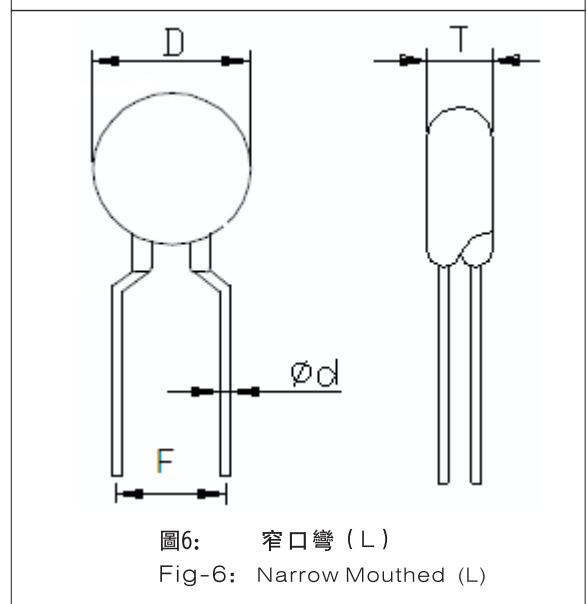
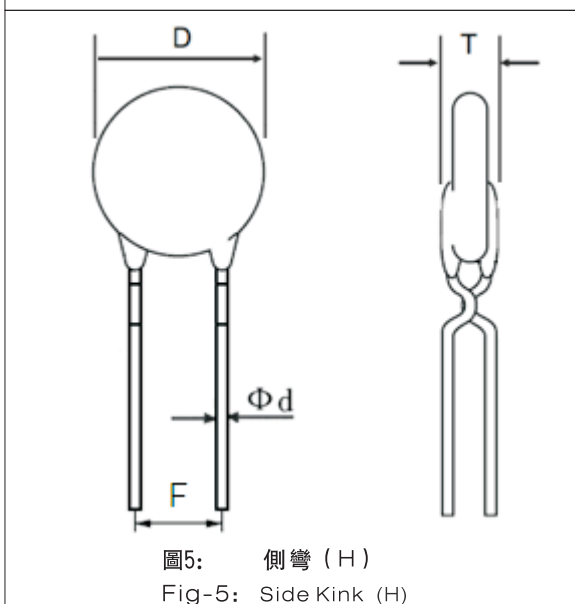
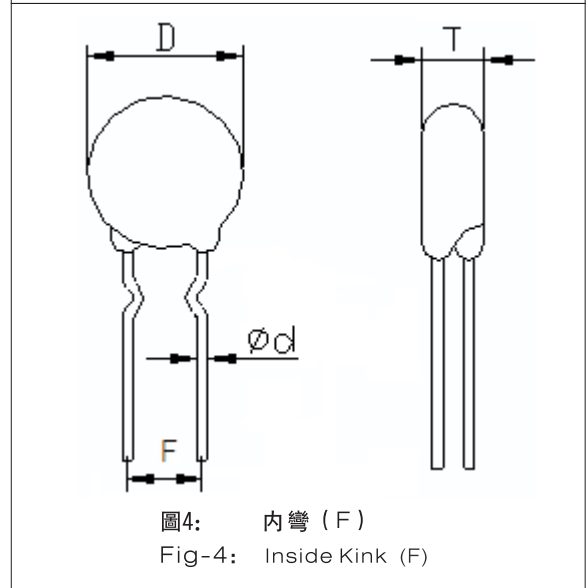
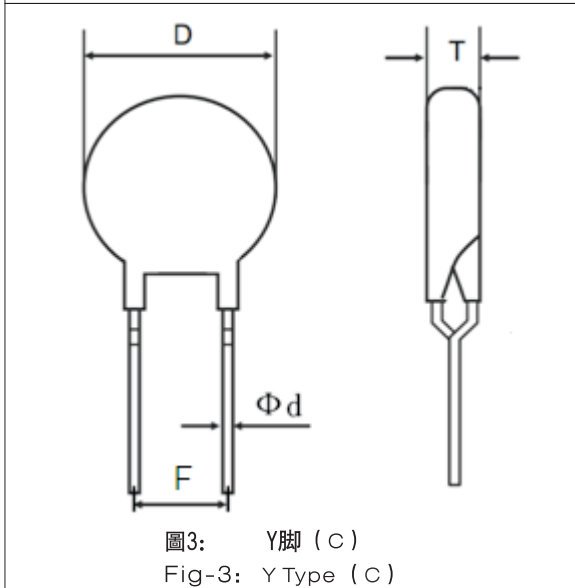
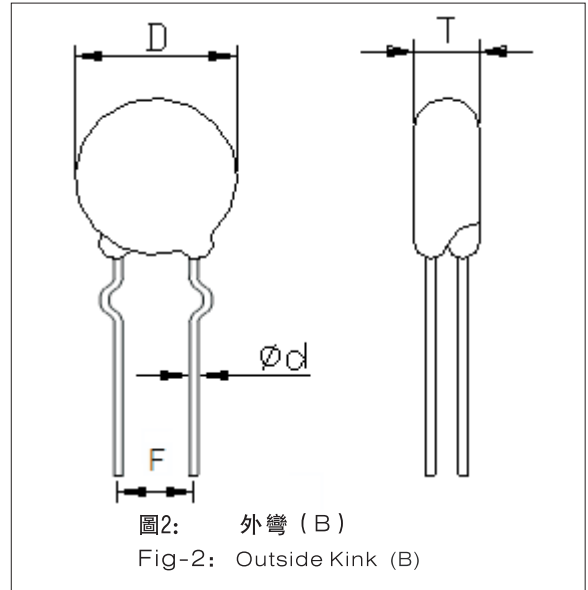
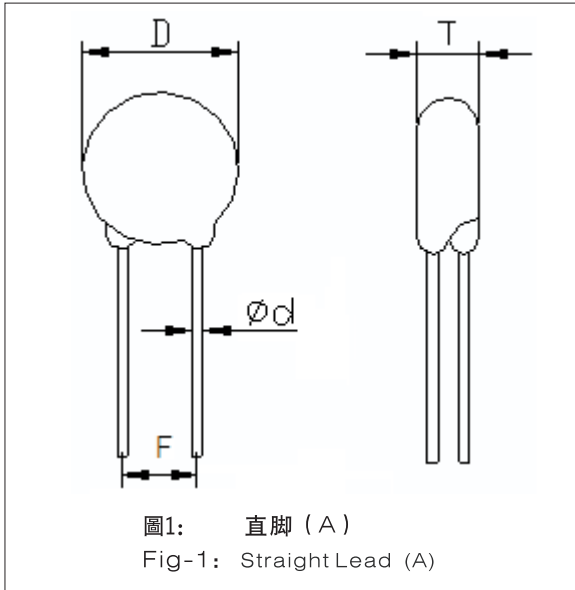

• 外形圖 Outline Fig



圖7: 窄口彎+Y脚 (Y)
Fig-7: Narrow Mouthed & Y Type(Y)



圖8: 直脚+90° 彎 (T)
Fig-8: Straight Lead & 90° Kink(T)

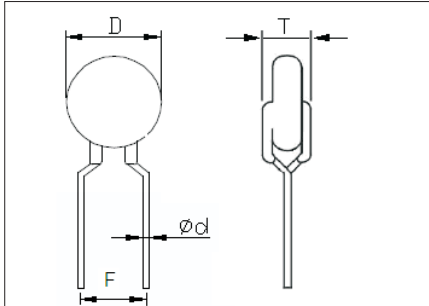

圖9: 外彎+Y脚 (D)
Fig-9: Outside Kink & Y Type (D)

• 外形尺寸 DIMENSIONS (mm)

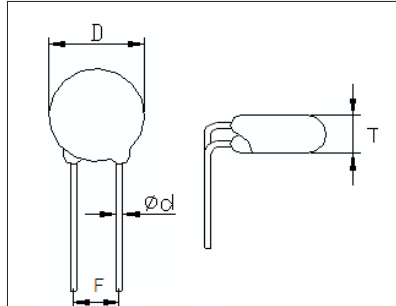
規格 Type	D_{MAX}	$F \pm 0.5$	T_{MAX}	$\Phi d \pm 0.05$
D-5	6.5	5.0	5	0.6
D-7	8.5	5.0	5	0.6 / 0.5
D-9	10.5	7.5	5	0.8
D-11	12.5	7.5	5	0.8
D-13	14.5	7.5	6	0.8
D-15	16.5	7.5	6	0.8
D-20	22	10	7	1.0

• 編帶產品 TAPING SPECIFICATION

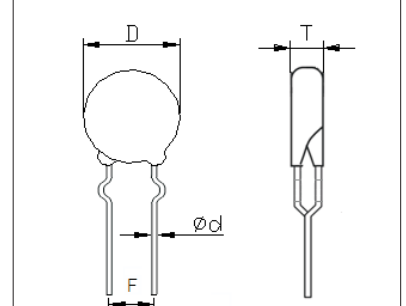
圖A Fig-A :

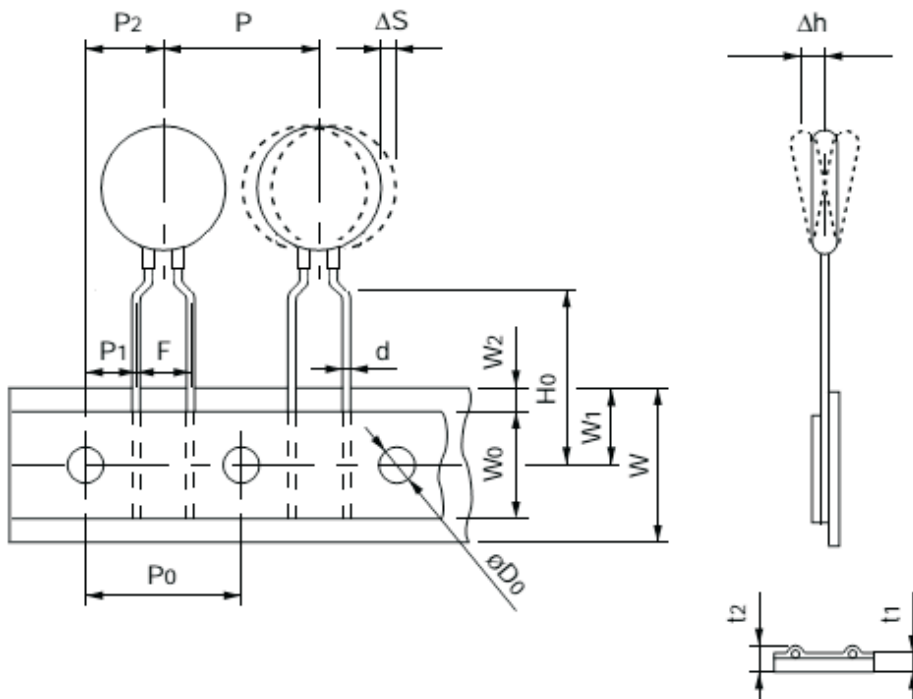

圖B Fig-B :

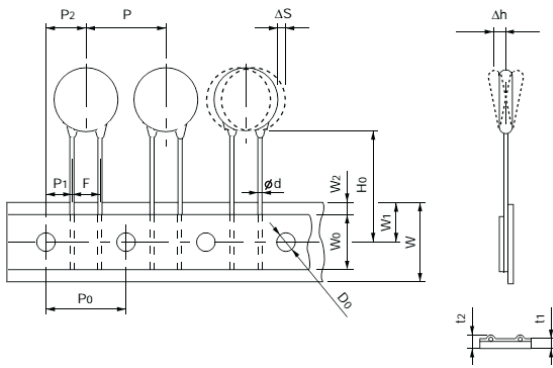

圖C Fig-C :

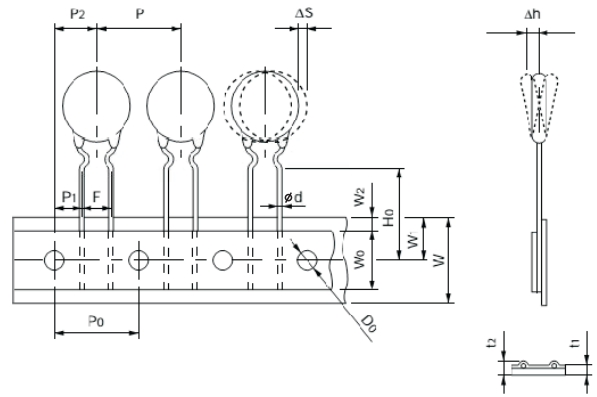

圖D Fig-D :

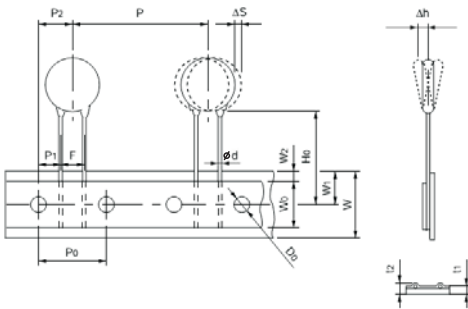

圖E Fig-E :

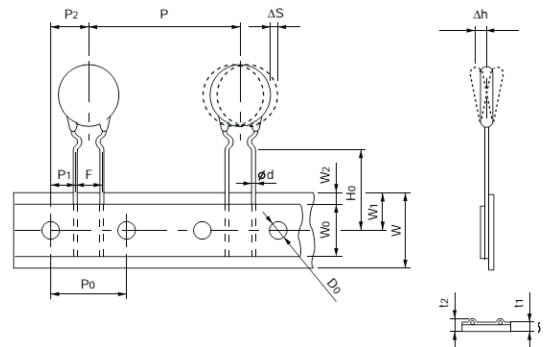

圖F Fig-F :

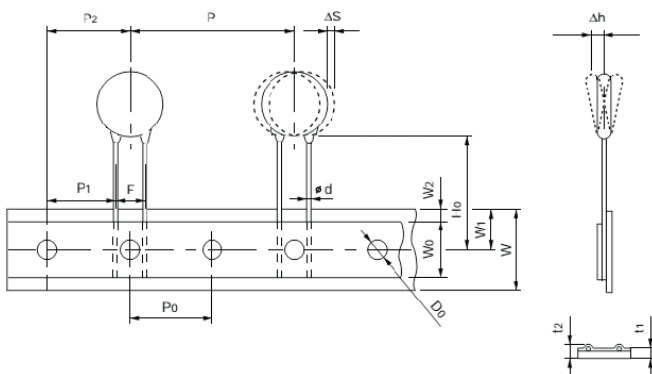

圖G Fig-G :

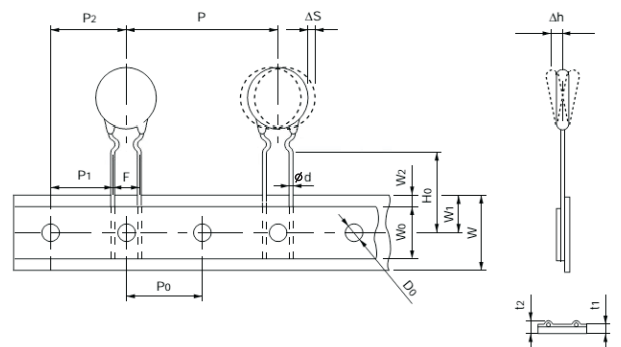

NTC熱敏電阻器 NTC THERMISTORS

• 編帶尺寸 Taping Dimensions (mm):

Series Symbol	D-5	D-7	D-9、D-11		D-13、D-15		D-20
圖形 Fig	圖A	圖B、圖C	圖B、圖C	圖F、圖G	圖F、圖G	圖D、圖E	圖F、圖G
P	12.7±1.0	12.7±1.0	15.0±1.0	25.4±1.0	25.4±1.0	30.0±1.0	25.4±1.0
P ₀	12.7±0.5	12.7±0.5	15.0±0.5	12.7±0.5	12.7±0.5	15.0±0.5	12.7±0.5
P ₁	3.85±0.70	3.85±0.70	3.75±0.70	8.95±0.70	8.95±0.70	3.75±0.70	7.7±0.70
P ₂	6.35±1.30	6.35±1.30	7.5±1.30	12.7±1.30	12.7±1.30	7.5±1.30	12.7±1.30
F	5.0±0.5	5.0±0.5	7.5±0.5	7.5±0.5	7.5±0.5	7.5±0.5	10.0±0.5
∅ d	0.6±0.05	0.6±0.05	0.8±0.05	0.8±0.05	0.8±0.05	0.8±0.05	1.0±0.05
W	18±0.5	18±0.5	18±0.5	18±0.5	18±0.5	18±0.5	18±0.5
W ₀	10.0 Min	10.0 Min	12.5 Min	12.5 Min	12.5 Min	12.5 Min	12.5 Min
W ₁	9.0±0.5	9.0±0.5	9.0±0.5	9.0±0.5	9.0±0.5	9.0±0.5	9.0±0.5
W ₂	3.0 Max	3.0 Max	3.0 Max	3.0 Max	3.0 Max	3.0 Max	3.0 Max
H ₀	16.0±0.5	圖B:19.0±1.0 圖C:16.0±0.5	圖B:19.0±1.0 圖C:16.0±0.5	圖F:19.0±1.0 圖G:16.0±0.5	圖F:19.0±1.0 圖G:16.0±0.5	圖D:19.0±1.0 圖E:16.0±0.5	圖F:19.0±1.0 圖G:16.0±0.5
D ₀	4.0±0.2	4.0±0.2	4.0±0.2	4.0±0.2	4.0±0.2	4.0±0.2	4.0±0.2
ΔS	0±2.0	0±2.0	0±2.0	0±2.0	0±2.0	0±2.0	0±2.0
Δh	0±2.0	0±2.0	0±2.0	0±2.0	0±2.0	0±2.0	0±2.0
t1	0.6±0.3	0.6±0.3	0.6±0.3	0.6±0.3	0.6±0.3	0.6±0.3	0.6±0.3
t2	1.6 Max	1.6 Max	2.0 Max	2.0 Max	2.0 Max	2.0 Max	2.0 Max

• 包裝方式及數量 (參考) PACKAGING & QUANTITY (Reference)

規格 Type	數量 Quantity		
	散裝/塑料袋 Bluk / Plastic bag		編帶/盒裝 Tape / Paper Box
	長腳 Long Lead	剪短腳 Cut Lead	
D-5	1000PCS	1000PCS	1500PCS
D-7	1000PCS	1000PCS	1500PCS
D-9	500PCS	1000PCS	1000PCS
D-11	500PCS	1000PCS	1000PCS
D-13	400PCS	500PCS	800PCS
D-15	300PCS	500PCS	800PCS
D-20	200PCS	200PCS	500PCS

• 電性能 SPECIFICATIONS & PROPERTIES

型號 Model	電阻值 R ₂₅ ±20% (Ω)	最大穩態 電流 Max. Steady current (A)	最大電流時 近似電阻值 Approx R of Max.current (Ω)	最大允許 電容量 @240V _{AC} Max. Allowable capacitance (μF)	耗散系數 Power Dissipation coefficient (mW/°C)	時間常數 Time Constant (s)	最大額定功率 Max. Power Rating (W)	工作溫度範圍 Operating Temperature Range (°C)				
NTC 4D-5	4	2	0.415	100	15	17	1.8	-40~150				
NTC 5D-5	5	2	0.429	100								
FNR 6D-5	6	2	0.458	100								
NTC 8D-5	8	1	1.089	100								
NTC 9D-5	9	1	1.112	100								
NTC 10D-5	10	1	1.126	100								
NTC 12D-5	12	1	1.184	100								
NTC 15D-5	15	1	1.202	100								
NTC 16D-5	16	0.7	1.253	100								
NTC 20D-5	20	0.6	1.275	100								
NTC 22D-5	22	0.6	1.313	68								
NTC 30D-5	30	0.5	1.429	68								
NTC 33D-5	33	0.5	1.466	68								
NTC 50D-5	50	0.5	1.727	68								
NTC 60D-5	60	0.5	1.878	68								
NTC 3.3D-7	3.3	2.3	0.245	100	16	27	2.0	-40~150				
NTC 4.7D-7	4.7	2.3	0.259	100								
NTC 5D-7	5	2.3	0.273	100								
NTC 8D-7	8	2	0.436	100								
NTC 10D-7	10	1.5	0.572	100								
NTC 12D-7	12	1.5	0.745	100								
NTC 15D-7	15	1.5	0.846	100								
NTC 16D-7	16	1.5	0.897	100								
NTC 20D-7	20	0.8	0.995	100								
NTC 22D-7	22	0.8	1.096	100								
NTC 30D-7	30	0.7	1.345	100								
NTC 33D-7	33	0.7	1.475	100								
NTC 2.5D-9	2.5	4	0.145	150					16	38	2.3	-40~170
NTC 3D-9	3	4	0.150	150								
NTC 4D-9	4	3	0.190	220								
NTC 4.7D-9	4.7	3	0.246	220								
NTC 5D-9	5	3	0.261	220								
NTC 6D-9	6	3	0.283	220								
NTC 7D-9	7	3	0.287	220								
NTC 8D-9	8	2.2	0.520	220								
NTC 10D-9	10	2	0.542	220								
NTC 12D-9	12	2	0.545	220								
NTC 15D-9	15	2	0.548	150								
NTC 16D-9	16	2	0.570	150								
NTC 20D-9	20	1	0.864	150								
NTC 22D-9	22	1	0.950	150								

NTC熱敏電阻器 NTC THERMISTORS

● 電性能 SPECIFICATIONS & PROPERTIES

型號 Model	電阻值 R ₂₅ ±20% (Ω)	最大穩態 電流 Max. Steady current (A)	最大電流時 近似電阻值 Approx R of Max.current (Ω)	最大允許 電容量 @240V _{AC} Max. Allowable capacitance (μF)	耗散系數 Power Dissipation coefficient (mW/°C)	時間常數 Time Constant (s)	最大額定功率 Max. Power Rating (W)	工作溫度範圍 Operating Temperature Range (°C)
NTC 25D-9	25	1	0.986	100	16	38	2.3	-40~170
NTC 30D-9	30	1	1.022	100				
NTC 33D-9	33	1	1.124	100				
NTC 50D-9	50	1	1.252	100				
NTC 60D-9	60	0.8	1.502	100				
NTC 80D-9	80	0.8	2.010	100				
NTC 100D-9	100	0.8	2.516	100				
NTC 120D-9	120	0.8	3.015	100				
NTC 200D-9	200	0.5	5.007	100				
NTC 300D-9	300	0.5	6.105	100				
NTC 2.5D-11	2.5	5	0.120	470	17	43	2.4	-40~170
NTC 3D-11	3	5	0.127	560				
NTC 4D-11	4	4	0.161	560				
NTC 5D-11	5	4	0.180	470				
NTC 6.8D-11	6.8	3	0.270	330				
NTC 8D-11	8	3	0.278	330				
NTC 10D-11	10	3	0.297	330				
NTC 12D-11	12	3	0.301	470				
NTC 13D-11	13	3	0.356	330				
NTC 15D-11	15	2.5	0.442	330				
NTC 16D-11	16	2.5	0.471	330				
NTC 20D-11	20	2	0.646	330				
NTC 22D-11	22	2	0.659	330				
NTC 25D-11	25	2	0.674	330				
NTC 30D-11	30	2	0.700	330				
NTC 33D-11	33	2	0.708	330				
NTC 47D-11	47	2	0.720	330				
NTC 50D-11	50	2	0.813	330				
NTC 60D-11	60	1.5	1.215	220				
NTC 80D-11	80	1.2	1.656	220				
NTC 100D-11	100	1.2	2.218	220				
NTC 120D-11	120	1.2	2.330	220				
NTC 2.5D-13	2.5	6	0.094	560	18	66	3.1	-40~200
NTC 3D-13	3	6	0.104	560				
NTC 4D-13	4	5	0.132	560				
NTC 4.7D-13	4.7	5	0.158	560				
NTC 5D-13	5	5	0.166	560				
NTC 6D-13	6	4	0.177	470				
NTC 7D-13	7	4	0.184	470				
NTC 8D-13	8	4	0.206	470				
NTC 10D-13	10	4	0.217	470				

• 電性能 SPECIFICATIONS & PROPERTIES

型號 Model	電阻值 R ₂₅ ±20% (Ω)	最大穩態 電流 Max. Steady current (A)	最大電流時 近似電阻值 Approx R of Max.current (Ω)	最大允許 電容量 @240 V _{AC} Max. Allowable capacitance (μF)	耗散系數 Power Dissipation coefficient (mW/°C)	時間常數 Time Constant (s)	最大額定功率 Max. Power Rating (W)	工作溫度範圍 Operating Temperature Range (°C)
NTC 12D-13	12	4	0.230	560	18	66	3.1	-40~200
NTC 15D-13	15	3	0.343	560				
NTC 16D-13	16	3	0.348	560				
NTC 18D-13	18	3	0.365	560				
NTC 20D-13	20	3	0.410	470				
NTC 22D-13	22	3	0.453	470				
NTC 30D-13	30	2.5	0.517	470				
NTC 33D-13	33	2.5	0.554	470				
NTC 47D-13	47	2.5	0.663	470				
NTC 60D-13	60	2	1.002	470				
NTC 120D-13	120	1.5	2.124	470				
NTC 1.3D-15	1.3	8	0.064	680	21	75	3.6	-40~200
NTC 1.5D-15	1.5	8	0.068	820				
NTC 2D-15	2	8	0.078	680				
NTC 2.2D-15	2.2	8	0.083	680				
NTC 2.5D-15	2.5	8	0.086	680				
NTC 3D-15	3	7	0.091	820				
NTC 4D-15	4	6	0.117	820				
NTC 5D-15	5	6	0.121	820				
NTC 6D-15	6	5	0.159	680				
NTC 7D-15	7	5	0.161	820				
NTC 8D-15	8	5	0.165	680				
NTC 10D-15	10	5	0.178	820				
NTC 12D-15	12	5	0.185	680				
NTC 15D-15	15	4	0.261	820				
NTC 16D-15	16	4	0.265	820				
NTC 18D-15	18	4	0.273	680				
NTC 20D-15	20	4	0.283	820				
NTC 22D-15	22	4	0.308	560				
NTC 25D-15	25	3.5	0.398	680				
NTC 30D-15	30	3.5	0.425	680				
NTC 33D-15	33	3.5	0.454	560				
NTC 40D-15	40	3	0.511	680				
NTC 47D-15	47	3	0.517	680				
NTC 80D-15	80	2.5	0.693	560				
NTC 120D-15	120	2	1.010	560				
NTC 1.3D-20	1.3	11	0.037	1000	28	113	4.9	-40~200
NTC 1.5D-20	1.5	10.5	0.041	1000				
NTC 2D-20	2	10	0.062	1000				
NTC 2.5D-20	2.5	9	0.073	1000				
NTC 3D-20	3	8.5	0.078	1000				

NTC熱敏電阻器 NTC THERMISTORS

● 電性能 SPECIFICATIONS & PROPERTIES

型號 Model	電阻值 R ₂₅ ± 20% (Ω)	最大穩態 電流 Max. Steady current (A)	最大電流時 近似電阻值 Approx R of Max.current (Ω)	最大允許 電容量 @240 V _{AC} Max. Allowable capacitance (μF)	耗散系數 Power Dissipation coefficient (mW/°C)	時間常數 Time Constant (s)	最大額定功率 Max. Power Rating (W)	工作溫度範圍 Operating Temperature Range (°C)
NTC 4D-20	4	8	0.080	1000	28	113	4.9	-40~200
NTC 4.7D-20	4.7	7.5	0.114	1000				
NTC 5D-20	5	7.5	0.118	1000				
NTC 6D-20	6	7	0.120	1000				
NTC 6.8D-20	6.8	6.5	0.130	1000				
NTC 7D-20	7	6.5	0.132	1000				
NTC 8D-20	8	6	0.161	1000				
NTC 10D-20	10	6	0.162	1000				
NTC 12D-20	12	5.5	0.180	1000				
NTC 13D-20	13	5.5	0.195	1000				
NTC 15D-20	15	5	0.205	1000				
NTC 16D-20	16	5	0.212	1000				
NTC 18D-20	18	4.5	0.260	1000				
NTC 20D-20	20	4.5	0.275	1000				
NTC 25D-20	25	4	0.365	1000				
NTC 30D-20	30	4	0.398	1000				
NTC 47D-20	47	4	0.497	1000				

注：“NTC □D-□”與“FNR □D-□”兩者對應的型號其性能參數是一樣的，
只是型號識別不同。

如：“NTC 10D-9”與“FNR 10D-9”性能參數是一樣的。

Note: The corresponding models of "NTC □D-□" and "FNR □D-□" have the same performance parameters, Only model recognition is different.

Example: "NTC 10D-9" and "FNR 10D-9", The performance parameters are the same.

X-ON Electronics

Largest Supplier of Electrical and Electronic Components

Click to view similar products for [NTC \(Negative Temperature Coefficient\) Thermistors](#) *category:*

Click to view products by [Fenghua Advanced](#) *manufacturer:*

Other Similar products are found below :

[118-253FAJ-P01](#) [121-202EAC-P01](#) [123-802EAJ-P01](#) [128-105NDP-Q02](#) [NTCALUG01A103F291L](#) [NTCLE410E3103F](#) [199-303KAF-A02](#)
[30054-4](#) [M09N038F](#) [500-52AA04-101](#) [526-31AA19-104](#) [526-31AN12-202](#) [103AT-5-1P-FT](#) [10K3A542I](#) [111-802EAJ-901](#) [112-103FAG-H02](#) [111-182CAG-H01](#) [112-103FAF-H01](#) [112-104KBF-F01](#) [526-31AA79-102](#) [44015RC](#) [194303KEVA01](#) [B57359V2224J260](#)
[B57621C5472K062](#) [135-105QAF-J02](#) [B57230V2103H260](#) [118-802EAJ-P01](#) [121-103FAC-Q02](#) [521-53AW02-104](#) [CL109R4120](#)
[GA100K6D234](#) [NXFT15XV103FEAB030](#) [USUR1000-502G-06](#) [GA10K3MR1I](#) [GA1K7CG3](#) [NXFT15WB473FEAB030](#) [GA10K3A542I](#)
[NTCLE213E3103JHT1](#) [PANR103338-490](#) [JSNA104F425FABXG](#) [JSNA103F345FABXG](#) [JSNA473F405FABXG](#) [JSNA103J395HABXG](#)
[JSNA103F344FBBXG](#) [JSNA103F338FABXG](#) [JSNA103F395FABXG](#) [SDNT1005X103F4050FTF](#) [SDNT1005X104F3950FTF](#)
[SDNT1005X473J4050HTF](#) [NTCF044EF474FTBX](#)