

■ PRS 系列功率电感器
PRS Series SMD Power Inductor
◆ 工作温度
Operation Temperature

-40℃~125℃

◆ 特征
Feature

- * 超薄
Ultra-thin design
- * 磁屏蔽结构
Magnetic shielding structure
- * 适合表面贴装
Suitable for surface mounting

◆ 应用
Application

- * 便携式通信设备, 笔记本电脑
Portable communication equipment, Notebook
- * DC/DC 转换
DC/DC conversion
- * 直流电源开关电源电路
DC switching power supply circuit

◆ 规格型号表示方法
Part Number

PRS	6045	-	1R0	M	T
产品代号 Product Code	尺寸(长×高) Dimension (Length × Thickness)		电感量 Inductance	公差 Tolerance	包装代号 Packaging code
PRS	2512→2.5×1.25mm 4018→4.0×1.8mm 6045→6.0×4.5mm 8040→8.0×4.0mm		R10→0.1 uH 1R0→1.0 uH 100→10 uH 101→100 uH 102→1000 uH	M→±20% N→±30%	T→ 卷带盘装 Tape & Reel

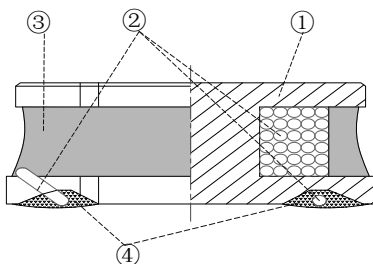
◆ 产品结构
Product Structure

No.	部位 Component	材料 Material
①	磁芯 Core	镍锌铁氧体磁芯 Ni-Zn ferrite core
②	线圈 Winding	漆包线 Enamelled Wire
③	保护层 Shield	导磁胶 Magnetic Glue
④	电极 Electrode	底层—银 Bottom Layer—Ag 镀层—镍层 Electroplated Coating—Ni 镀层—锡层 Electroplated Coating—Sn 表层—锡/铜 Surface Layer—Sn/Cu

◆规格尺寸
Dimension

* PRS2512 Type

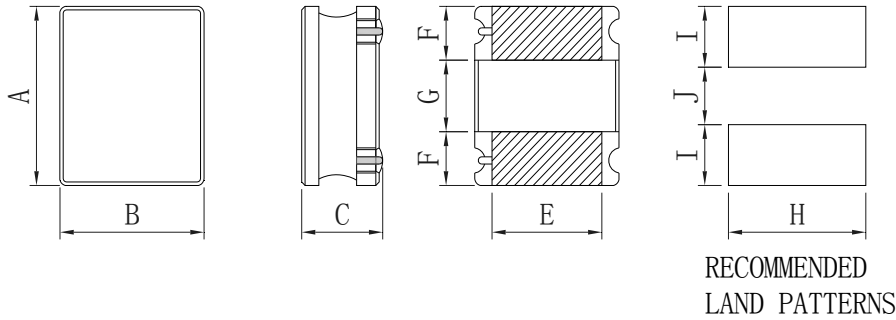

单位(Unit): mm

型号 Part	A	B	C	E (Typ.)	F (Typ.)	G (Typ.)	H (Typ.)	I (Typ.)	J (Typ.)
2512	2.5±0.2	2.1±0.2	1.25 Max	1.6	0.85	0.80	2.1	0.85	0.80

备注：顶部不印字。

Note: No marking on the top of inductors.

* PRS3015~PRS8040 Type

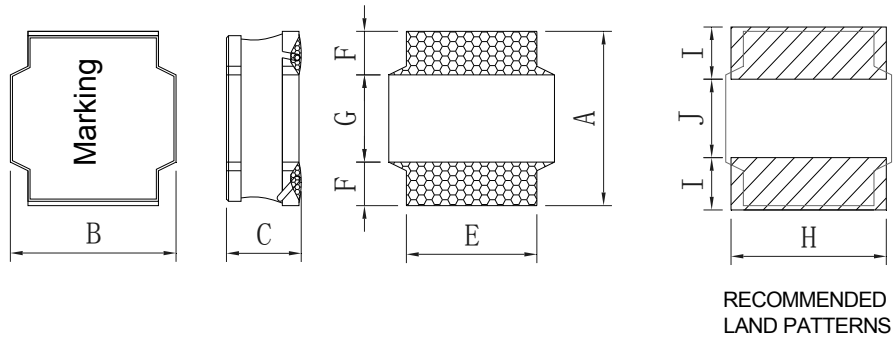

单位(Unit): mm

型号 Part	A	B	C	E (Typ.)	F (Typ.)	G (Typ.)	H (Typ.)	I (Typ.)	J (Typ.)
3015	3.0±0.2	3.0±0.2	1.5MAX	2.80	0.85	1.3	3.0	0.9	1.3
4018	4.0±0.2	4.0±0.2	1.8MAX	2.6±0.3	1.2	1.6	3.6	1.4	1.6
4020	4.0±0.2	4.0±0.2	2.0MAX	3.4	1.2	1.6	3.6	1.4	1.6
4026	4.0±0.2	4.0±0.2	2.6MAX	3.4	1.2	1.6	3.6	1.4	1.6
4030	4.0±0.2	4.0±0.2	3.0MAX	3.4	1.2	1.6	3.6	1.4	1.6
5020	5.0±0.2	5.0±0.2	2.1MAX	4.0	1.2	2.1	4.4	1.6	2.4
5040	5.0±0.2	5.0±0.2	4.2MAX	4.0	1.5	2.0	4.4	1.6	2.4
6020	6.0±0.2	6.0±0.2	2.0MAX	5.0	1.5	3.0	5.7	1.9	2.6
6028	6.0±0.2	6.0±0.2	2.8MAX	5.0	1.5	3.0	5.7	1.9	2.6
6045	6.0±0.2	6.0±0.2	4.5MAX	5.0	1.5	3.0	5.7	1.9	2.6
8040	8.0±0.2	8.0±0.2	4.3MAX	6.4	2.3	4.0	7.5	2.4	3.6

备注：PRS3015 顶部印字母；其他规格顶部印电感量标称值。

Note: PRS3015 printed on the top of the letter; other specifications printed on the top of the nominal value of inductance.

◆电性能参数
Electrical Characteristics

* PRS2512 Type

规格型号 Part No.	电感量 Inductance (μ H)	公差 Tolerance	测试频率 Test Freq.	直流电阻 Direct Current Resistance DCR(Ω)Max	饱和电流 Isat Saturation Current (A)	温升电流 Irms Temperature Rise Current (A)
PRS2512-R33NT	0.33	$\pm 20\%$	100KHz	0.049	4.00	3.35
PRS2512-R47NT	0.47	$\pm 20\%$	100KHz	0.061	3.82	2.15
PRS2512-R68NT	0.68	$\pm 20\%$	100KHz	0.074	3.28	1.96
PRS2512-1R0MT	1.0	$\pm 20\%$	100KHz	0.090	2.59	1.93
PRS2512-1R5MT	1.5	$\pm 20\%$	100KHz	0.147	2.24	1.40
PRS2512-2R2MT	2.2	$\pm 20\%$	100KHz	0.216	1.85	1.15
PRS2512-3R3MT	3.3	$\pm 20\%$	100KHz	0.264	1.61	1.04
PRS2512-4R7MT	4.7	$\pm 20\%$	100KHz	0.377	1.12	0.84
PRS2512-5R6MT	5.6	$\pm 20\%$	100KHz	0.538	1.11	0.73
PRS2512-6R8MT	6.8	$\pm 20\%$	100KHz	0.581	0.98	0.69
PRS2512-8R2MT	8.2	$\pm 20\%$	100KHz	0.658	0.98	0.65
PRS2512-100MT	10	$\pm 20\%$	100KHz	0.690	0.79	0.62

* PRS3015 Type

规格型号 Part No.	电感量 Inductance (μ H)	公差 Tolerance	测试频率 Test Freq.	直流电阻 Direct Current Resistance DCR(Ω)	饱和电流 Isat Saturation Current (A)	温升电流 Irms Temperature Rise Current (A)
PRS3015-R22NT	0.22	$\pm 20\%$	100KHz	0.016 $\pm 20\%$	5.00	3.50
PRS3015-R47NT	0.47	$\pm 20\%$	100KHz	0.020 $\pm 20\%$	3.90	2.60
PRS3015-R68NT	0.68	$\pm 20\%$	100KHz	0.025 $\pm 20\%$	3.00	2.45
PRS3015-1R0NT	1.00	$\pm 20\%$	100KHz	0.030 $\pm 20\%$	2.32	2.35
PRS3015-1R5NT	1.50	$\pm 20\%$	100KHz	0.040 $\pm 20\%$	2.30	1.70
PRS3015-2R2NT	2.20	$\pm 20\%$	100KHz	0.060 $\pm 20\%$	1.60	1.60
PRS3015-2R7NT	2.70	$\pm 20\%$	100KHz	0.075 $\pm 20\%$	1.52	1.43
PRS3015-3R3NT	3.30	$\pm 20\%$	100KHz	0.080 $\pm 20\%$	1.32	1.36
PRS3015-4R7MT	4.70	$\pm 20\%$	100KHz	0.120 $\pm 20\%$	1.10	1.09
PRS3015-5R6MT	5.60	$\pm 20\%$	100KHz	0.140 $\pm 20\%$	0.95	0.86
PRS3015-6R2MT	6.20	$\pm 20\%$	100KHz	0.160 $\pm 20\%$	1.00	0.86
PRS3015-6R8MT	6.80	$\pm 20\%$	100KHz	0.160 $\pm 20\%$	0.87	0.85
PRS3015-8R2MT	8.20	$\pm 20\%$	100KHz	0.220 $\pm 20\%$	0.80	0.80
PRS3015-100MT	10.00	$\pm 20\%$	100KHz	0.230 $\pm 20\%$	0.72	0.77
PRS3015-150MT	15.00	$\pm 20\%$	100KHz	0.360 $\pm 20\%$	0.66	0.65
PRS3015-180MT	18.00	$\pm 20\%$	100KHz	0.430 $\pm 20\%$	0.56	0.59
PRS3015-220MT	22.00	$\pm 20\%$	100KHz	0.520 $\pm 20\%$	0.52	0.57
PRS3015-330MT	33.00	$\pm 20\%$	100KHz	0.840 $\pm 20\%$	0.44	0.43
PRS3015-390MT	39.00	$\pm 20\%$	100KHz	1.100 $\pm 20\%$	0.40	0.40
PRS3015-470MT	47.00	$\pm 20\%$	100KHz	1.340 $\pm 20\%$	0.35	0.35

*** PRS4018 Type**

规格型号 Part No.	电感量 Inductance (μ H)	公差 Tolerance	测试频率 Test Freq.	直流电阻 Direct Current Resistance DCR(Ω)	饱和电流 Isat Saturation Current (A)	温升电流 Irms Temperature Rise Current (A)
PRS4018-R24NTS00	0.24	$\pm 30\%$	100KHz	0.014 $\pm 30\%$	9.00	5.00
PRS4018-R47NTS00	0.47	$\pm 30\%$	100KHz	0.021 $\pm 30\%$	6.50	4.00
PRS4018-R68NTS00	0.68	$\pm 30\%$	100KHz	0.020 $\pm 30\%$	4.90	3.30
PRS4018-1R0NTS00	1.00	$\pm 30\%$	100KHz	0.030 $\pm 30\%$	4.30	2.00
PRS4018-1R5NTS00	1.50	$\pm 30\%$	100KHz	0.040 $\pm 30\%$	3.35	1.80
PRS4018-2R2MTS00	2.20	$\pm 20\%$	100KHz	0.045 $\pm 30\%$	2.70	1.65
PRS4018-2R7MTS00	2.70	$\pm 20\%$	100KHz	0.058 $\pm 30\%$	2.30	1.45
PRS4018-3R3MTS00	3.30	$\pm 20\%$	100KHz	0.070 $\pm 30\%$	2.45	1.23
PRS4018-4R7MTS00	4.70	$\pm 20\%$	100KHz	0.090 $\pm 30\%$	1.70	1.20
PRS4018-5R6MTS00	5.60	$\pm 20\%$	100KHz	0.107 $\pm 30\%$	1.60	1.50
PRS4018-6R8MTS00	6.80	$\pm 20\%$	100KHz	0.110 $\pm 30\%$	1.45	1.06
PRS4018-8R2MTS00	8.20	$\pm 20\%$	100KHz	0.160 $\pm 30\%$	1.35	0.90
PRS4018-100MTS00	10.00	$\pm 20\%$	100KHz	0.180 $\pm 30\%$	1.30	0.84
PRS4018-120MTS00	12.00	$\pm 20\%$	100KHz	0.190 $\pm 30\%$	1.10	1.00
PRS4018-150MTS00	15.00	$\pm 20\%$	100KHz	0.250 $\pm 30\%$	0.94	0.65
PRS4018-220MTS00	22.00	$\pm 20\%$	100KHz	0.360 $\pm 30\%$	0.80	0.59
PRS4018-330MTS00	33.00	$\pm 20\%$	100KHz	0.530 $\pm 30\%$	0.65	0.49
PRS4018-390MTS00	39.00	$\pm 20\%$	100KHz	0.670 $\pm 30\%$	0.60	0.45
PRS4018-470MTS00	47.00	$\pm 20\%$	100KHz	0.650 $\pm 30\%$	0.57	0.42
PRS4018-560MTS00	56.00	$\pm 20\%$	100KHz	0.900 $\pm 30\%$	0.51	0.38
PRS4018-680MTS00	68.00	$\pm 20\%$	100KHz	1.000 $\pm 30\%$	0.47	0.32
PRS4018-820MTS00	82.00	$\pm 20\%$	100KHz	1.300 $\pm 30\%$	0.43	0.28
PRS4018-101MTS00	100.00	$\pm 20\%$	100KHz	1.500 $\pm 30\%$	0.40	0.25

*** PRS4020 Type**

规格型号 Part No.	电感量 Inductance (μ H)	公差 Tolerance	测试频率 Test Freq.	直流电阻 Direct Current Resistance DCR(Ω)	饱和电流 Isat Saturation Current (A)	温升电流 Irms Temperature Rise Current (A)
PRS4020-1R0MT	1.0	$\pm 20\%$	100KHz	0.029 $\pm 30\%$	4.78	2.15
PRS4020-1R5MT	1.5	$\pm 20\%$	100KHz	0.035 $\pm 30\%$	4.45	1.98
PRS4020-2R2MT	2.2	$\pm 20\%$	100KHz	0.040 $\pm 30\%$	3.40	1.85
PRS4020-3R3MT	3.3	$\pm 20\%$	100KHz	0.070 $\pm 30\%$	3.20	1.40
PRS4020-4R7MT	4.7	$\pm 20\%$	100KHz	0.075 $\pm 30\%$	2.35	1.34
PRS4020-5R1MT	5.1	$\pm 20\%$	100KHz	0.085 $\pm 30\%$	2.30	1.27
PRS4020-5R6MT	5.6	$\pm 20\%$	100KHz	0.090 $\pm 30\%$	2.20	1.22
PRS4020-6R8MT	6.8	$\pm 20\%$	100KHz	0.125 $\pm 30\%$	2.20	1.04
PRS4020-8R2MT	8.2	$\pm 20\%$	100KHz	0.155 $\pm 30\%$	1.75	1.04
PRS4020-100MT	10.0	$\pm 20\%$	100KHz	0.165 $\pm 30\%$	1.60	0.90
PRS4020-150MT	15.0	$\pm 20\%$	100KHz	0.230 $\pm 30\%$	1.35	0.77
PRS4020-220MT	22.0	$\pm 20\%$	100KHz	0.350 $\pm 30\%$	1.05	0.62
PRS4020-270MT	27.0	$\pm 20\%$	100KHz	0.545 $\pm 30\%$	1.02	0.50

PRS4020-330MT	33.0	±20%	100KHz	0.550±30%	0.85	0.49
PRS4020-390MT	39.0	±20%	100KHz	0.650±30%	0.82	0.46
PRS4020-470MT	47.0	±20%	100KHz	0.710±30%	0.74	0.44
PRS4020-560MT	56.0	±20%	100KHz	0.800±30%	0.66	0.41
PRS4020-680MT	68.0	±20%	100KHz	1.060±30%	0.61	0.36
PRS4020-820MT	82.0	±20%	100KHz	1.170±30%	0.50	0.34
PRS4020-101MT	100.0	±20%	100KHz	1.550±30%	0.48	0.31

* PRS4026 Type

规格型号 Part No.	电感量 Inductance (μ H)	公差 Tolerance	测试频率 Test Freq.	直流电阻 Direct Current Resistance DCR(Ω)	饱和电流 Isat Saturation Current (A)	温升电流 Irms Temperature Rise Current (A)
PRS4026-1R0NT	1.0	±30%	100KHz	0.017±30%	3.10	2.80
PRS4026-1R5NT	1.5	±30%	100KHz	0.022±30%	2.40	2.30
PRS4026-2R2MT	2.2	±20%	100KHz	0.030±30%	2.10	2.00
PRS4026-3R3MT	3.3	±20%	100KHz	0.037±30%	1.80	1.70
PRS4026-4R7MT	4.7	±20%	100KHz	0.055±30%	1.45	1.60
PRS4026-6R8MT	6.8	±20%	100KHz	0.065±30%	1.30	1.50
PRS4026-100MT	10	±20%	100KHz	0.085±30%	1.00	1.30
PRS4026-150MT	15	±20%	100KHz	0.110±30%	0.90	1.10
PRS4026-220MT	22	±20%	100KHz	0.200±30%	0.60	0.90
PRS4026-330MT	33	±20%	100KHz	0.270±30%	0.54	0.80
PRS4026-470MT	47	±20%	100KHz	0.400±30%	0.40	0.65
PRS4026-101MT	100	±20%	100KHz	0.770±30%	0.33	0.33

* PRS4030 Type

规格型号 Part No.	电感量 Inductance (μ H)	公差 Tolerance	测试频率 Test Freq.	直流电阻 Direct Current Resistance DCR(Ω)	饱和电流 Isat Saturation Current (A)	温升电流 Irms Temperature Rise Current (A)
PRS4030-1R0NT	1.0	±30%	100KHz	0.016±30%	5.26	4.15
PRS4030-1R5NT	1.5	±30%	100KHz	0.020±30%	4.84	3.34
PRS4030-2R2NT	2.2	±30%	100KHz	0.030±30%	4.90	3.00
PRS4030-3R3NT	3.3	±30%	100KHz	0.040±30%	3.30	2.40
PRS4030-3R9MT	3.9	±20%	100KHz	0.057±30%	3.00	2.10
PRS4030-4R7MT	4.7	±20%	100KHz	0.060±30%	2.90	2.00
PRS4030-6R8MT	6.8	±20%	100KHz	0.090±30%	2.20	1.60
PRS4030-8R2MT	8.2	±20%	100KHz	0.090±30%	2.10	1.60
PRS4030-100MT	10.0	±20%	100KHz	0.100±30%	1.95	1.50
PRS4030-150MT	15.0	±20%	100KHz	0.190±30%	1.65	1.11
PRS4030-220MT	22.0	±20%	100KHz	0.250±30%	1.30	1.00
PRS4030-330MT	33.0	±20%	100KHz	0.330±30%	1.10	0.84
PRS4030-470MT	47.0	±20%	100KHz	0.600±30%	0.95	0.72
PRS4030-680MT	68.0	±20%	100KHz	0.868±30%	0.72	0.52
PRS4030-820MT	82.0	±20%	100KHz	1.060±30%	0.66	0.47
PRS4030-101MT	100.0	±20%	100KHz	1.150±30%	0.60	0.45

PRS4030-121MT	120.0	±20%	100KHz	1.350±30%	0.57	0.55
PRS4030-151MT	150.0	±20%	100KHz	2.350±30%	0.50	0.35

*** PRS5020 Type**

规格型号 Part No.	电感量 Inductance (μ H)	公差 Tolerance	测试频率 Test Freq.	直流电阻 Direct Current Resistance DCR(Ω)	饱和电流 Isat Saturation Current (A)	温升电流 Irms Temperature Rise Current (A)
PRS5020-1R0NT	1.0	±30%	100KHz	0.020±30%	4.40	3.80
PRS5020-2R2NT	2.2	±30%	100KHz	0.033±30%	3.20	2.90
PRS5020-3R3NT	3.3	±30%	100KHz	0.043±30%	2.55	2.50
PRS5020-4R7NT	4.7	±30%	100KHz	0.058±30%	2.50	2.20
PRS5020-5R6NT	5.6	±30%	100KHz	0.068±30%	2.30	2.05
PRS5020-6R8MT	6.8	±20%	100KHz	0.075±30%	2.05	1.80
PRS5020-8R2MT	8.2	±20%	100KHz	0.096±30%	1.85	1.65
PRS5020-100MT	10	±20%	100KHz	0.120±30%	1.70	1.55
PRS5020-150MT	15	±20%	100KHz	0.165±30%	1.35	1.25
PRS5020-180MT	18	±20%	100KHz	0.200±30%	1.25	1.15
PRS5020-220MT	22	±20%	100KHz	0.220±30%	1.15	1.10
PRS5020-330MT	33	±20%	100KHz	0.350±30%	0.92	0.90
PRS5020-390MT	39	±20%	100KHz	0.410±30%	0.80	0.80
PRS5020-470MT	47	±20%	100KHz	0.520±30%	0.77	0.77
PRS5020-560MT	56	±20%	100KHz	0.600±30%	0.77	0.70
PRS5020-680MT	68	±20%	100KHz	0.680±30%	0.65	0.64
PRS5020-820MT	82	±20%	100KHz	0.860±30%	0.55	0.55
PRS5020-101MT	100	±20%	100KHz	1.100±30%	0.53	0.53

*** PRS5040 Type**

规格型号 Part No.	电感量 Inductance (μ H)	公差 Tolerance	测试频率 Test Freq.	直流电阻 Direct Current Resistance DCR(Ω)	饱和电流 Isat Saturation Current (A)	温升电流 Irms Temperature Rise Current (A)
PRS5040-1R0NT	1.0	±30%	100KHz	0.012±30%	7.35	4.90
PRS5040-1R5NT	1.5	±30%	100KHz	0.014±30%	6.00	4.50
PRS5040-1R8NT	1.8	±30%	100KHz	0.016±30%	5.50	4.30
PRS5040-2R2NT	2.2	±30%	100KHz	0.018±30%	4.90	3.80
PRS5040-3R3NT	3.3	±30%	100KHz	0.024±30%	3.95	3.40
PRS5040-4R7NT	4.7	±30%	100KHz	0.030±30%	3.50	3.00
PRS5040-5R6NT	5.6	±30%	100KHz	0.040±30%	3.00	2.80
PRS5040-6R8MT	6.8	±20%	100KHz	0.045±30%	2.90	2.50
PRS5040-8R2MT	8.2	±20%	100KHz	0.055±30%	2.70	2.30
PRS5040-100MT	10.0	±20%	100KHz	0.066±30%	2.35	2.10
PRS5040-150MT	15.0	±20%	100KHz	0.090±30%	2.00	2.00
PRS5040-220MT	22.0	±20%	100KHz	0.130±30%	1.60	1.50
PRS5040-330MT	33.0	±20%	100KHz	0.200±30%	1.30	1.20
PRS5040-390MT	39.0	±20%	100KHz	0.230±30%	1.20	1.10
PRS5040-470MT	47.0	±20%	100KHz	0.300±30%	1.00	1.00

PRS5040-560MT	56.0	±20%	100KHz	0.330±30%	0.95	0.85
PRS5040-680MT	68.0	±20%	100KHz	0.420±30%	0.90	0.80
PRS5040-820MT	82.0	±20%	100KHz	0.500±30%	0.80	0.75
PRS5040-101MT	100.0	±20%	100KHz	0.620±30%	0.75	0.70
PRS5040-151MT	150.0	±20%	100KHz	0.850±30%	0.65	0.60
PRS5040-181MT	180.0	±20%	100KHz	1.150±30%	0.50	0.43
PRS5040-221MT	220.0	±20%	100KHz	1.200±30%	0.46	0.42
PRS5040-331MT	330.0	±20%	100KHz	1.750±30%	0.40	0.36
PRS5040-391MT	390.0	±20%	100KHz	2.500±30%	0.35	0.32
PRS5040-471MT	470.0	±20%	100KHz	2.850±30%	0.32	0.30
PRS5040-561MT	560.0	±20%	100KHz	3.200±30%	0.30	0.28
PRS5040-681MT	680.0	±20%	100KHz	3.750±30%	0.27	0.25
PRS5040-821MT	820.0	±20%	100KHz	5.700±30%	0.24	0.22
PRS5040-102MT	1000.0	±20%	100KHz	6.500±30%	0.21	0.19

* PRS6020 Type

规格型号 Part No.	电感量 Inductance (μ H)	公差 Tolerance	测试频率 Test Freq.	直流电阻 Direct Current Resistance DCR(Ω)	饱和电流 Isat Saturation Current (A)	温升电流 I _{rms} Temperature Rise Current (A)
PRS6020-1R0NT	1.0	±30%	100KHz	0.020±30%	4.15	3.50
PRS6020-1R5NT	1.5	±30%	100KHz	0.022±30%	4.00	3.20
PRS6020-2R2NT	2.2	±30%	100KHz	0.028±30%	3.75	2.75
PRS6020-3R3NT	3.3	±30%	100KHz	0.035±30%	3.15	2.60
PRS6020-4R7NT	4.7	±30%	100KHz	0.058±30%	3.00	2.00
PRS6020-6R8NT	6.8	±30%	100KHz	0.079±30%	2.20	1.80
PRS6020-100MT	10	±20%	100KHz	0.105±30%	1.75	1.40
PRS6020-150MT	15	±20%	100KHz	0.145±30%	1.20	1.20
PRS6020-220MT	22	±20%	100KHz	0.204±30%	1.05	1.00
PRS6020-330MT	33	±20%	100KHz	0.300±30%	0.95	0.84
PRS6020-470MT	47	±20%	100KHz	0.430±30%	0.70	0.65
PRS6020-680MT	68	±20%	100KHz	0.660±30%	0.62	0.60
PRS6020-101MT	100	±20%	100KHz	1.200±30%	0.50	0.45

* PRS6028 Type

规格型号 Part No.	电感量 Inductance (μ H)	公差 Tolerance	测试频率 Test Freq.	直流电阻 Direct Current Resistance DCR(Ω)	饱和电流 Isat Saturation Current (A)	温升电流 I _{rms} Temperature Rise Current (A)
PRS6028-1R0NT	1.0	±30%	100KHz	0.014±30%	5.75	5.20
PRS6028-1R5NT	1.5	±30%	100KHz	0.016±30%	5.00	4.58
PRS6028-2R2NT	2.2	±30%	100KHz	0.020±30%	5.10	3.75
PRS6028-3R3NT	3.3	±30%	100KHz	0.023±30%	3.60	3.48
PRS6028-3R9NT	3.9	±30%	100KHz	0.028±30%	3.00	3.20
PRS6028-4R7NT	4.7	±30%	100KHz	0.031±30%	2.70	3.08
PRS6028-6R8NT	6.8	±20%	100KHz	0.048±30%	2.30	2.40
PRS6028-8R2NT	8.2	±20%	100KHz	0.055±30%	2.30	2.25

PRS6028-100MT	10	±20%	100KHz	0.065±30%	1.90	1.95
PRS6028-150MT	15	±20%	100KHz	0.095±30%	1.60	1.45
PRS6028-220MT	22	±20%	100KHz	0.135±30%	1.30	1.40
PRS6028-270MT	27	±20%	100KHz	0.155±30%	1.50	1.32
PRS6028-330MT	33	±20%	100KHz	0.220±30%	1.10	1.22
PRS6028-390MT	39	±20%	100KHz	0.225±30%	1.25	1.10
PRS6028-470MT	47	±20%	100KHz	0.300±30%	0.95	1.06
PRS6028-680MT	68	±20%	100KHz	0.420±30%	0.76	0.86
PRS6028-820MT	82	±20%	100KHz	0.520±30%	0.64	0.70
PRS6028-101MT	100	±20%	100KHz	0.570±30%	0.62	0.70
PRS6028-151MT	150	±20%	100KHz	0.760±30%	0.50	0.50
PRS6028-221MT	220	±20%	100KHz	1.200±30%	0.38	0.38
PRS6028-331MT	330	±20%	100KHz	1.800±30%	0.32	0.32
PRS6028-471MT	470	±20%	100KHz	2.300±30%	0.28	0.28

* PRS6045 Type

规格型号 Part No.	电感量 Inductance (μ H)	公差 Tolerance	测试频率 Test Freq.	直流电阻 Direct Current Resistance DCR(Ω)	饱和电流 Isat Saturation Current (A)	温升电流 I _{rms} Temperature Rise Current (A)
PRS6045-1R0NT	1.0	±30%	100KHz	0.014±30%	8.50	5.14
PRS6045-1R3NT	1.3	±30%	100KHz	0.016±30%	8.00	5.05
PRS6045-1R5NT	1.5	±30%	100KHz	0.016±30%	8.35	5.05
PRS6045-1R8NT	1.8	±30%	100KHz	0.018±30%	7.00	4.95
PRS6045-2R2NT	2.2	±30%	100KHz	0.021±30%	6.00	4.60
PRS6045-3R0NT	3.0	±30%	100KHz	0.024±30%	5.00	3.80
PRS6045-3R3NT	3.3	±30%	100KHz	0.024±30%	5.00	3.70
PRS6045-3R9MT	3.9	±20%	100KHz	0.028±30%	4.50	3.50
PRS6045-4R7MT	4.7	±20%	100KHz	0.031±30%	4.00	3.30
PRS6045-5R6MT	5.6	±20%	100KHz	0.035±30%	3.80	3.15
PRS6045-6R3MT	6.3	±20%	100KHz	0.035±30%	3.80	3.15
PRS6045-6R8MT	6.8	±20%	100KHz	0.038±30%	3.80	3.00
PRS6045-8R2MT	8.2	±20%	100KHz	0.043±30%	3.50	2.70
PRS6045-100MT	10	±20%	100KHz	0.047±30%	3.20	2.45
PRS6045-120MT	12	±20%	100KHz	0.058±30%	2.80	2.20
PRS6045-150MT	15	±20%	100KHz	0.077±30%	2.50	2.05
PRS6045-220MT	22	±20%	100KHz	0.115±30%	2.05	1.80
PRS6045-330MT	33	±20%	100KHz	0.145±30%	1.65	1.45
PRS6045-390MT	39	±20%	100KHz	0.210±30%	1.50	1.25
PRS6045-470MT	47	±20%	100KHz	0.220±30%	1.40	1.20
PRS6045-560MT	56	±20%	100KHz	0.260±30%	1.30	1.10
PRS6045-680MT	68	±20%	100KHz	0.330±30%	1.20	1.00
PRS6045-820MT	82	±20%	100KHz	0.450±30%	1.05	0.90
PRS6045-101MT	100	±20%	100KHz	0.500±30%	0.95	0.80
PRS6045-121MT	120	±20%	100KHz	0.466±30%	0.88	0.79

PRS6045-151MT	150	±20%	100KHz	0.800±30%	0.80	0.70
PRS6045-181MT	180	±20%	100KHz	0.950±30%	0.75	0.65
PRS6045-221MT	220	±20%	100KHz	1.200±30%	0.70	0.59
PRS6045-331MT	330	±20%	100KHz	1.700±30%	0.57	0.57
PRS6045-471MT	470	±20%	100KHz	1.800±30%	0.50	0.42
PRS6045-681MT	680	±20%	100KHz	3.550±30%	0.42	0.33
PRS6045-102MT	1000	±20%	100KHz	4.500±30%	0.30	0.20

* PRS8040 Type

规格型号 Part No.	电感量 Inductance (μ H)	公差 Tolerance	测试频率 Test Freq.	直流电阻 Direct Current Resistance DCR(Ω)	饱和电流 Isat Saturation Current (A)	温升电流 Irms Temperature Rise Current (A)
PRS8040-R90NT	0.9	±30%	100KHz	0.006±30%	11.00	7.80
PRS8040-1R0NT	1.0	±30%	100KHz	0.006±30%	11.00	7.80
PRS8040-1R4NT	1.4	±30%	100KHz	0.010±30%	9.00	7.00
PRS8040-1R5NT	1.5	±30%	100KHz	0.010±30%	8.15	5.65
PRS8040-2R0NT	2.0	±30%	100KHz	0.009±30%	7.40	6.30
PRS8040-2R2NT	2.2	±30%	100KHz	0.009±30%	7.40	6.30
PRS8040-2R8NT	2.8	±30%	100KHz	0.014±30%	5.80	5.10
PRS8040-3R3MT	3.3	±20%	100KHz	0.015±30%	5.30	4.90
PRS8040-3R6MT	3.6	±20%	100KHz	0.015±30%	5.30	4.90
PRS8040-3R8MT	3.8	±20%	100KHz	0.015±30%	5.30	4.90
PRS8040-4R7MT	4.7	±20%	100KHz	0.018±30%	4.70	4.10
PRS8040-5R6MT	5.6	±20%	100KHz	0.021±30%	6.00	3.85
PRS8040-6R8MT	6.8	±20%	100KHz	0.025±30%	4.00	3.70
PRS8040-8R2MT	8.2	±20%	100KHz	0.028±30%	4.20	3.45
PRS8040-100MT	10	±20%	100KHz	0.034±30%	3.40	3.10
PRS8040-120MT	12	±20%	100KHz	0.041±30%	3.50	2.80
PRS8040-150MT	15	±20%	100KHz	0.050±30%	2.70	2.40
PRS8040-180MT	18	±20%	100KHz	0.066±30%	2.70	2.30
PRS8040-220MT	22	±20%	100KHz	0.066±30%	2.20	2.20
PRS8040-270MT	27	±20%	100KHz	0.083±30%	2.00	2.00
PRS8040-330MT	33	±20%	100KHz	0.100±30%	1.90	1.70
PRS8040-390MT	39	±20%	100KHz	0.120±30%	1.70	1.60
PRS8040-470MT	47	±20%	100KHz	0.150±30%	1.50	1.40
PRS8040-560MT	56	±20%	100KHz	0.180±30%	1.55	1.45
PRS8040-680MT	68	±20%	100KHz	0.230±30%	1.20	1.10
PRS8040-750MT	75	±20%	100KHz	0.211±30%	1.35	1.20
PRS8040-800MT	80	±20%	100KHz	0.230±30%	1.30	1.15
PRS8040-820MT	82	±20%	100KHz	0.225±30%	1.30	1.20
PRS8040-101MT	100	±20%	100KHz	0.290±30%	1.00	1.00
PRS8040-121MT	120	±20%	100KHz	0.334±30%	1.05	0.95
PRS8040-151MT	150	±20%	100KHz	0.480±30%	0.95	0.85
PRS8040-221MT	220	±20%	100KHz	0.660±30%	0.85	0.80

PRS8040-331MT	330	±20%	100KHz	1.020±30%	0.68	0.64
PRS8040-471MT	470	±20%	100KHz	1.500±30%	0.60	0.60
PRS8040-681MT	680	±20%	100KHz	2.040±30%	0.50	0.45
PRS8040-102MT	1000	±20%	100KHz	2.800±30%	0.40	0.35
PRS8040-152MT	1500	±20%	100KHz	4.300±30%	0.32	0.26

备注：测试电压为 0.5V。

Remarks: The test voltage is 0.5V.

Isat: 指使电感量比初始值下降 30% 的电流值, 加载电流的时间 1 秒以内。

The DC current at which the inductance drops 30% from its value without current, load current time within 1s.

Irms: 指使电感器表面温度上升 40℃ 的电流值。

The DC current that increases the surface temperature of the inductor by 40℃.

◆可靠性测试方法

Reliability Test Method

序号 No.	项目 Items	要求 Requirements	试验方法及备注 Test Methods and Remarks
1	绝缘电阻 Insulation Resistance	≥100MΩ	在电感器线圈和磁芯之间施加 100 V 直流电压保持 60s。 100 V DC between inductor coil and core for 60 seconds.
2	可焊性 Solderability	电极面 95% 以上覆盖新的焊料。 95% or more of electrode area shall be coated by new solder.	在 245±5℃ 熔融的焊锡 (96.5Sn/3.0Ag/0.5Cu) 中浸 5±1s。 Dip pads in flux and dip in solder pot (96.5Sn/3.0Ag/0.5Cu) at 245±5℃ for (5±1) seconds.
3	耐焊接热 Resistance to Soldering Heat	外观无可见机械损伤; 电感量变化率: ±10% 以内。 No visible mechanical damage. Inductance change: Within ±10%	在 260±5℃ 熔融的焊锡 (96.5Sn/3.0Ag/0.5Cu) 中浸 10±1s。 Dip pads in flux and dip in solder pot (96.5Sn/3.0Ag/0.5Cu) at 260±5℃ for (10±1) seconds.
4	端子强度 Terminal Strength	元件端子无松动、无脱落。 No looseness of shedding of terminals.	使用焊料将电感器焊接到试验板上, 然后按箭头方向分别施加 10N 的力, 保持时间 10±1s。 The inductor is welded to the test plate with solder, and then applied 10 N force in the direction of arrow and kept for 10 ± 1s. 
5	耐高温 High Temperature	外观无可见机械损伤; 电感量变化率: ±10% 以内。 No visible mechanical damage. Inductance change: Within ±10%	温度+125±2℃, 时间 1000 ^{±2} h, 在室温下放置 2 小时后、48 小时内测试。 Temperature 125±2℃, time 1000 ^{±2} h, test within 48 hours after 2 hours of placement at room temperature.
6	耐低温 Low Temperature	外观无可见机械损伤; 电感量变化率: ±10% 以内。 No visible mechanical damage. Inductance change: Within ±10%	温度-40±2℃, 时间 1000 ^{±2} h; 在室温下放置 2 小时后、48 小时内测试。 Temperature -40℃ ± 2℃, time 1000 ^{±2} h, test within 48 hours after 2 hours of placement at room temperature.
7	温度冲击 Thermal Shock	外观无可见机械损伤; 电感量变化率: ±10% 以内。 No visible mechanical damage. Inductance change: Within ±10%	(-40±3)℃, 时间(30±3) min ↔ (125±2)℃/(30±3) min, 转换时间(2~3) min, 循环 32 次; 在室温下放置 2 小时后、48 小时内测试。 The test sample shall be placed at (-40±3)℃ and (125±2)℃ for (30±3) min, different temperature conversion time is 2~3 minutes. The temperature cycle shall be repeated 32 cycles. Test within 48 hours after 2 hours of placement at room temperature.
8	温度特性 Temperature Characteristic	电感量变化率 P_{c-b}, P_{c-d} 不超过 ±20%。 Inductance change P_{c-b}, P_{c-d} Within ±20%	在 -40℃ ~ +125℃ 的环境下测量电感量值, 分别与 20℃ 环境下测量的电感量进行比较。 Based on the inductance at 20℃ and Measured at the ambient of -40℃ ~ +125℃.

(续上表 Continue the above table)

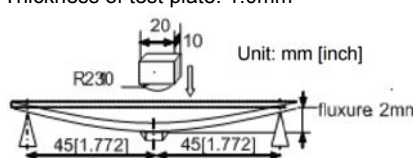
序号 No.	项目 Items	要求 Requirements	试验方法及备注 Test Methods and Remarks
9	恒定湿热 Constant Damp Heat	外观无可见机械损伤; 电感量变化率: $\pm 10\%$ 以内。 No visible mechanical damage. Inductance change: Within $\pm 10\%$	将电感器放置于湿度(90~95)%RH,温度 $60\pm 2^\circ\text{C}$ 的环境中存放 $1000\pm 24\text{h}$, 在室温下放置 2 小时后、48 小时内测试。 The inductors were stored for $1000 + 240\text{ h}$ at humidity (90~95)%RH, temperature $60\pm 2^\circ\text{C}$, and tested within 48h after 2H at room temperature.
10	振动 Vibration	外观无可见机械损伤; 电感量变化率: $\pm 10\%$ 以内。 No visible mechanical damage. Inductance change: Within $\pm 10\%$	使用焊料将电感器焊接到试验板上, 试验板固定于振动试验夹具使之与振动台刚性连接。试验按以下条件进行: 振动频率范围: 10Hz~55Hz 振幅: 1.5mm (加速度 $\leq 196\text{m/s}^2$) 一次循环时间: 1min (10Hz→55Hz→10Hz) 振动时间: X/Y/Z 轴各 2H (共 6H) The inductor is welded to the test plate with solder, and the test plate is fixed to the vibration test fixture so that it is rigidly connected with the vibration table. The test shall be conducted according to the following conditions: Vibration frequency range: 10Hz~55Hz Amplitude: 1.5mm (Acceleration $\leq 196\text{m/s}^2$) One cycle time: 1min (10Hz → 55Hz → 10Hz) Vibration time: 2 hours for X/Y/Z axis (Total of 6 hours)
11	弯曲试验 Resistance to Flexure	外观无可见机械损伤; No visible mechanical damage.	使用焊料将电感器焊接到试验板上, 然后施加一个垂直方向的力(如图所示), 试验按以下条件进行: 弯曲度: 2mm 加压速度: 0.5mm/s 保持时间: $30\pm 1\text{s}$ 测试板厚度: 1.0mm The inductor is welded to the test plate with solder, and then apply a vertical force (as shown in the figure). The test shall be conducted according to the following conditions: Curvature: 2mm Pressurization speed: 0.5mm/s Holding time: $30 \pm 1\text{ s}$ Thickness of test plate: 1.0mm 
12	高温负载 (寿命) High-temperature Load (Life-span)	外观无可见机械损伤; 电感量变化率: $\pm 10\%$ 以内。 No visible mechanical damage. Inductance change: Within $\pm 10\%$	温度 $85^\circ\text{C}\pm 2^\circ\text{C}$, 时间 $1000\pm 24\text{h}$, 施加额定电流, 在室温下放置 2 小时后、48 小时内测试。 Temperature $85^\circ\text{C} \pm 2^\circ\text{C}$, Time $1000\pm 24\text{h}$, apply a rated current, test within 48 hours after 2 hours of placement at room temperature. 注: 加载电流时零件表面温度超过 125°C 的, 需要对电流降额到零件表面温度不超过 125°C 。 Note: If the surface temperature of the part over 125°C when the current is loaded, the current need to reduce until the surface temperature of the part less than 125°C .

◆包装
Packaging

* 载带尺寸

Tape Dimension

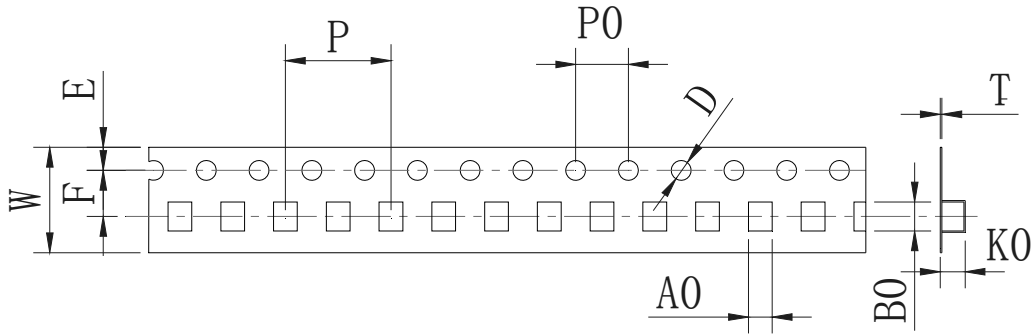

单位(Unit): mm

型号 Part	W	A0	B0	D	D1	E	F	K0	P0	P2	P	T
2512	8±0.3	2.4±0.2	2.65±0.2	1.5±0.2	---	1.75±0.2	3.5±0.2	1.4±0.2	4.0±0.2	2.0±0.2	4.0±0.3	0.25±0.05

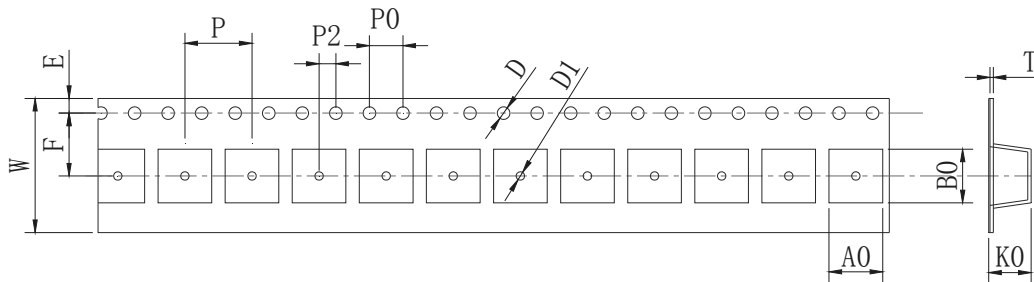

单位(Unit): mm

型号 Part	W	A0	B0	D	D1	E	F	K0	P0	P2	P	T
3015	8.0±0.3	3.3±0.1	3.3±0.1	1.5±0.1	---	1.75±0.1	3.5±0.1	1.9±0.1	4.0±0.1	2.0±0.1	4.0±0.1	0.25±0.1
4018	12±0.5	4.3±0.3	4.3±0.3	1.5±0.3	1.5±0.3	1.75±0.3	5.5±0.3	2.1±0.3	4.0±0.3	2.0±0.3	8.0±0.3	0.30±0.1
4020	12±0.5	4.3±0.3	4.3±0.3	1.5±0.3	1.5±0.3	1.75±0.3	5.5±0.3	2.1±0.3	4.0±0.3	2.0±0.3	8.0±0.3	0.30±0.1
4026	12±0.5	4.3±0.3	4.3±0.3	1.5±0.3	1.5±0.3	1.75±0.3	5.5±0.3	2.8±0.3	4.0±0.3	2.0±0.3	8.0±0.3	0.30±0.1
4030	12±0.5	4.3±0.3	4.3±0.3	1.5±0.3	1.5±0.3	1.75±0.3	5.5±0.3	3.1±0.1	4.0±0.3	2.0±0.3	8.0±0.3	0.30±0.1
5020	12±0.5	5.3±0.3	5.3±0.3	1.5±0.3	1.5±0.3	1.75±0.3	5.5±0.3	2.2±0.3	4.0±0.3	2.0±0.3	8.0±0.3	0.30±0.1
5040	12±0.5	5.5±0.3	5.5±0.3	1.5±0.3	1.5±0.3	1.75±0.3	5.5±0.3	4.4±0.3	4.0±0.3	2.0±0.3	8.0±0.3	0.40±0.1
6020	12±0.5	6.3±0.3	6.3±0.3	1.5±0.3	1.5±0.3	1.75±0.3	5.5±0.3	2.2±0.3	4.0±0.3	2.0±0.3	8.0±0.3	0.30±0.1
6028	16±0.5	6.4±0.3	6.4±0.3	1.5±0.3	1.5±0.3	1.75±0.3	7.5±0.3	3.4±0.3	4.0±0.3	2.0±0.3	8.0±0.3	0.35±0.1
6045	16±0.5	6.4±0.3	6.4±0.3	1.5±0.3	1.5±0.3	1.75±0.3	7.5±0.3	4.7±0.3	4.0±0.3	2.0±0.3	8.0±0.3	0.40±0.1
8040	16±0.5	8.4±0.3	8.4±0.3	1.5±0.3	1.5±0.3	1.75±0.3	7.5±0.3	4.7±0.3	4.0±0.3	2.0±0.3	12±0.3	0.40±0.1

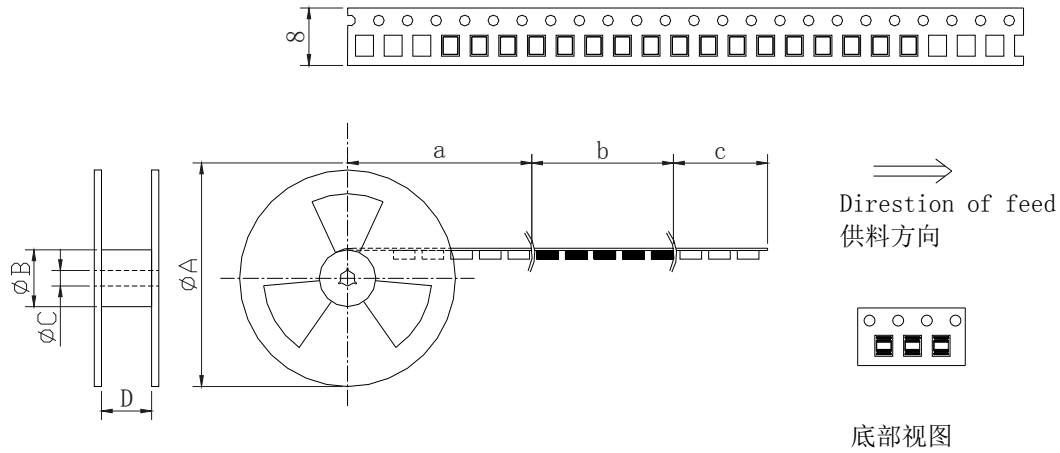
*** 卷盘尺寸及供料方向**
Reel Size & Direction Of Feed

单位(Unit): mm

型号 Part	A (Typ.)	B (Typ.)	C (Typ.)	D (Typ.)	a	b	c
2512	178	58	13	8.4	空带 Blank portions	装元件 Chip cavity	引带 Leader

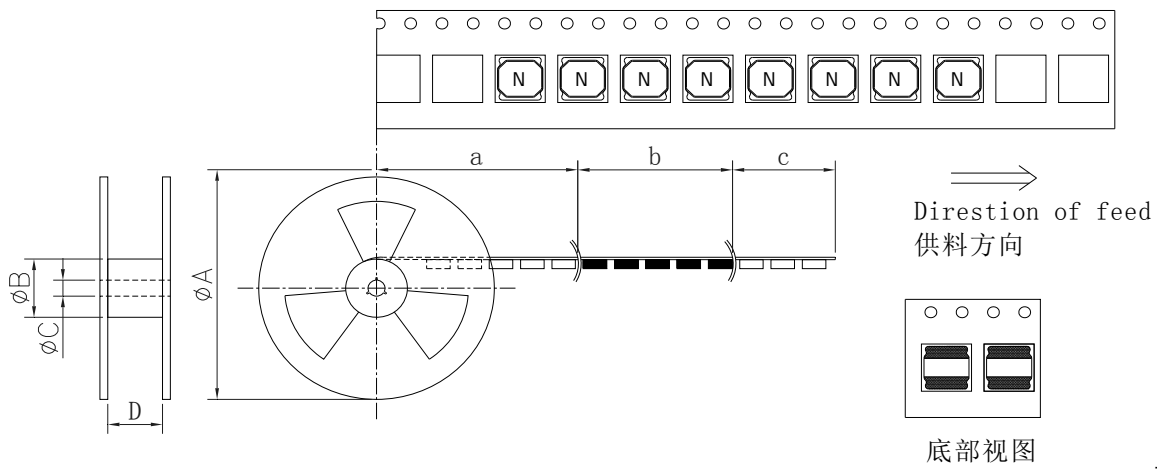

单位(Unit):

mm

型号 Part	A (Typ.)	B (Typ.)	C (Typ.)	D (Typ.)	a	b	c
3015	178	58	13	8.4	空带 Blank portions	装元件 Chip cavity	引带 Leader

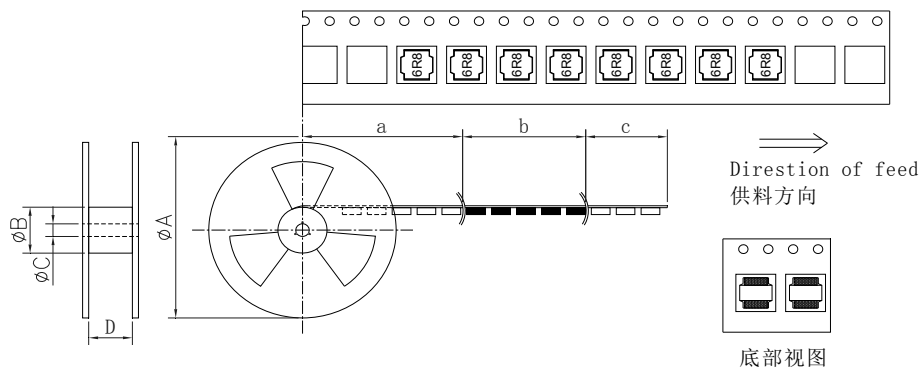

单位(Unit): mm

型号 Part	A (Typ.)	B (Typ.)	C (Typ.)	D (Typ.)	a	b	c
4018	330	100	13	12.4	空带 Blank portions	装元件 Chip cavity	引带 Leader
4020	330	100	13	12.4			
4026	330	100	13	12.4			
4030	330	100	13	12.4			
5020	330	100	13	12.4			
5040	330	100	13	12.4			
6020	330	100	13	12.4			
6028	330	100	13	16.4			
6045	330	100	13	16.4			
8040	330	100	13	16.4			

* 包装数量

Packing quantity

型号 Part	卷盘 Reel (PCS)	纸盒 Box (PCS)	纸箱 Carton (PCS)
2512	3,000	15,000	150,000
3015	2,000	10,000	100,000
4018	3,000	15,000	45,000
4020	3,000	15,000	45,000
4026	2,500	12,500	37,500
4030	2,000	10,000	30,000
5020	2,500	12,500	37,500
5040	2,000	10,000	30,000
6020	2,500	12,500	37,500
6028	2,000	8,000	24,000
6045	1,500	6,000	18,000
8040	1,000	4,000	12,000

◆ 推荐使用的焊接曲线
Recommended soldering profile

- * 本产品建议使用回流焊接法

Applicable soldering process to the products is reflow soldering.

- * 焊接材料

焊料: Sn-3.0Ag-0.5Cu

Solder: Sn-3.0Ag-0.5Cu

助焊剂: 使用松香基助焊剂, 禁止使用卤化物含量超过 0.2wt% 的强酸性助焊剂和水溶性助焊剂。

Flux: Use rosin-based flux, but not strongly acidic flux (with chlorine exceeding 0.2 wt%). Do not use water-soluble flux.

- * 焊接曲线

Soldering Profile

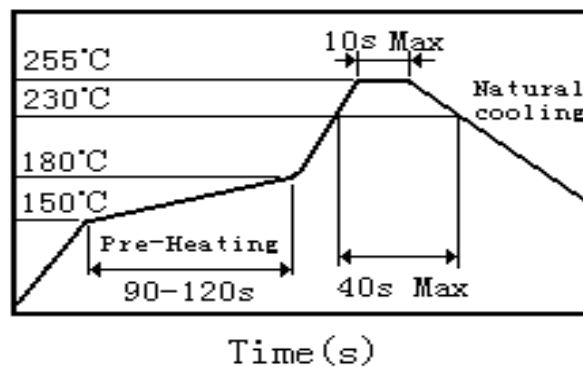
◆ 贮存要求
Storage Requirements

- * 存储期限: 为保证电感的焊接特性和包装材料处于良好状态, 请于本公司发货后 6 个月内使用本产品。同时, 由于电感的焊接特性会随时间发生变化, 如果贮存时间超过 6 个月, 请首先确认其焊接特性后再使用。

Storage Period: In order to ensure that the welding characteristics and packaging materials of the inductor are in good condition, please use this product within 6 months after the company ships it. At the same time, because the welding characteristics of the inductor will change with time, if the storage time exceeds 6 months, please confirm its welding characteristics before use.

- * 存储条件:

温度: -10 to +40°C (编带包装的电感器); -40 to +85°C (电感器本体)

相对湿度: 30~70%RH

Storage Conditions:

Temperature: -10 to +40°C (Inductors With Taping); -40 to +85°C (Inductors Body)

Humidity: 30~70%RH

X-ON Electronics

Largest Supplier of Electrical and Electronic Components

Click to view similar products for [Fixed Inductors](#) category:

Click to view products by [Fenghua Advanced](#) manufacturer:

Other Similar products are found below :

[CR32NP-100KC](#) [70F224AI](#) [MHQ1005P10NJ](#) [MHQ1005P1N0S](#) [MHQ1005P2N4S](#) [MHQ1005P3N6S](#) [MHQ1005P5N1S](#) [MHQ1005P8N2J](#)
[PE-53601NL](#) [PE-53602NL](#) [PG0936.113NLT](#) [9220-20](#) [9310-16](#) [PM06-2N7](#) [PM06-39NJ](#) [A01TK](#) [1206CS-471XJ](#) [HC2-R47-R](#) [HC8-1R2-R](#)
[HCF1305-3R3-R](#) [1206CS-151XG](#) [RCH664NP-4R7M](#) [RCP1317NP-391L](#) [DH2280-4R7M](#) [DS1608C-106](#) [B10TJ](#) [B82498B3101J000](#) [ELJ-](#)
[RE27NJF2](#) [1812CS-153XJ](#) [1812CS-183XJ](#) [1812CS-223XJ](#) [1812LS-104XJ](#) [1812LS-105XJ](#) [1812LS-124XJ](#) [1812LS-154XJ](#) [1812LS-223XJ](#)
[1812LS-224XJ](#) [1812LS-563XJ](#) [1812LS-683XJ](#) [1812LS-824XJ](#) [NIN-FB101JTR110F](#) [NIN-FB471JTR62F](#) [NIN-FC1R5JTR220F](#) [NIN-](#)
[HCR15JTRF](#) [NIN-HCR33JTRF](#) [NIN-HDR22JTRF](#) [NIN-HDR82JTRF](#) [NIN-HK2N7STRF](#) [NIN-PA150KTR370F](#) [NIN-PB100KTR550F](#)