



承 认 书

APPROVAL SHEET

客户名称

CUSTOMER : _____

产品名称

安全规格认证多层片式陶瓷电容器

PART NAME: _____ **Safety Recognized MLCC**

规格

SPECIFICATION: _____ **1808~2220 TYPE**

版本

VERSION: _____

日期

DATE OF ISSUE: _____

制 造 MANUFACTURER			客 户 CUSTOMER		
拟制 DESIGN	审核 CHECK	批准 APPROVAL	检验 INSPECTOR	审核 CHECK	批准 APPROVAL



安全规格认证多层片式陶瓷电容器 Safety Recognized MLCC

一、特性

*新型独石结构, 体积小, 电容量高, 能在高压下工作。

*符合 60384-14 标准。

*仅用于回流焊接。

*它们实用于薄型设备。

●应用范围

*适合于无变压器的 DAA 调制调解器线路滤波器及耦合用。

*适合信息设备线路滤波器用。

●Features

* A New monolithic structure capacitor for small, high-capacitance capability of operating at high-voltage levels.

*Available for equipment base on UL60950-1.

*Only for reflow soldering

*Fit for use on thin type equipment.

●Application

*Ideal for use on line filters and couplings for DAA modems without transformers.

*Ideal for use on line filters for information equipment.



二、结构及尺寸 STRUCTURE AND DIMENSIONS

※ 尺寸 DIMENSIONS

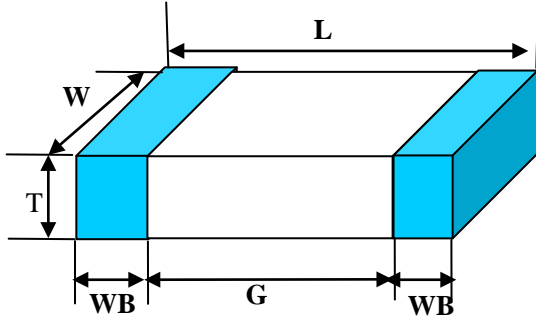

型号 Type		尺寸 Dimensions (mm)				
英制表示 British expression	公制表示 Metric expression	L	W	T	WB	G
1808	4520	4.50 ± 0.40	2.00 ± 0.20	≤ 2.50	≤ 0.7	≥ 4.0
1812	4532	4.50 ± 0.40	3.20 ± 0.30	≤ 3.50	≤ 0.7	≥ 4.0
2211	5728	5.70 ± 0.40	2.80 ± 0.30	≤ 3.50	≤ 1.0	≥ 4.0
2220	5750	5.70 ± 0.40	5.00 ± 0.40	≤ 3.50	≤ 1.0	≥ 4.0

备注：可根据客户的特殊要求设计符合客户需求的产品。

Note: We can design according to customer special requirements.



三、型号规格表示方法 HOW TO ORDER

SC 08 B 102 K 302 XA L
① ② ③ ④ ⑤ ⑥ ⑦ ⑧

※说明 NOTES:

① SC 代表安规电容器

② 尺寸 DIMENSIONS

单位 (unit): inch/ mm

代号	08	12	11	20
尺寸规格 Size Code	1808	1812	2211	2220
长×宽 (L×W) inch	0.18×0.08	0.18×0.12	0.22×0.11	0.22×0.20
长×宽 (L×W) mm	4.50×2.00	4.50×3.20	5.70×2.80	5.70×5.00

③ 介质种类 DIELECTRIC STYLE

介质种类 (Dielectric Code)	CG	B
介质材料 (Dielectric)	COG	X7R

④ 标称容量 NOMINAL CAPACITANCE

位 (unit): pF

表示方式 (Express Method)	实际值 (Actual Value)	注: 头两位数字为有效数字, 第三位数字为0的个数; R为小数点。 Note: the first two digits are significant; third digit denotes number of zeros; R=decimal point.
102	10×10^2	
222	22×10^2	

⑤ 容量误差 CAPACITANCE TOLERANCE

代码 (Code)	J	K	M
误差 (Tolerance)	±5.0%	±10.0%	±20%

⑥ 工作电压 Rated Voltage

单位 (unit): V

工作电压	交流 250V
------	---------

⑦ 代号 Code :

XA	XB	YB
X1 安规电容器	X2 安规电容器	Y2 安规电容器

代号	使用时的峰值脉冲电压 kV	耐久性试验前施加的峰值脉冲电压 kV
XA	$2.5\text{kV} < U \leq 4.0\text{kV}$	$C_R \leq 1.0 \mu\text{F}, 4$ $C_R > 1.0 \mu\text{F}, 4/\sqrt{C_R}$
XB	$\leq 2.5\text{kV}$	$C_R \leq 1.0 \mu\text{F}, 2.5$ $C_R > 1.0 \mu\text{F}, 2.5/\sqrt{C_R}$

代号	额定电压 V	耐久性试验前施加的峰值脉冲电压 kV
YB	$150\text{V} \leq U \leq 250\text{V}$	5.0



⑧厚度代号:

代号	厚度
L	1.6±0.2
M	1.8±0.2
N	2.0±0.3
O	2.5±0.3
P	2.8±0.3
Q	3.2±0.3
X	按照个别尺寸规格规定

四、电容量范围

项目	XA 安规电容器							
	COG				X7R			
材料	COG				X7R			
代号	08	12	11	20	08	12	11	20
尺寸	1808	1812	2211	2220	1808	1812	2211	2220
电容量								
2PF								
5PF								
6.8PF								
8.2PF								
10PF								
15PF								
22PF								
33PF								
47PF								
56PF								
68PF								
82PF								
100PF								
120PF								
150PF								
180PF								
220PF								
270PF								
330PF								
470PF								
560PF								
820PF								
1.0nF								
1.5nF								
2.2nF								
3.3nF								
4.7nF								



项目	XB 安规电容器			
材料	X7R			
代号	08	12	11	20
尺寸	1808	1812	2211	2220
电容量				
1.0 nF				
1.5 nF				
2.2 nF				
3.3 nF				
4.7 nF				
5.6 nF				
6.8 nF				
10nF				
15nF				
22nF				
33nF				
47nF				

项目	YB 安规电容器							
材料	COG				X7R			
代号	08	12	11	20	08	12	11	20
尺寸	1808	1812	2211	2220	1808	1812	2211	2220
电容量								
2PF								
5PF								
6.8PF								
8.2PF								
10PF								
15PF								
22PF								
33PF								
47PF								
56PF								
68PF								
82PF								
100PF								
120PF								
150PF								
180PF								



项目	YB 安规电容器							
材料	COG				X7R			
代号	08	12	11	20	08	12	11	20
尺寸	1808	1812	2211	2220	1808	1812	2211	2220
电容量								
220PF								
270PF								
330PF								
470PF								
560PF								
820PF								
1.0nF								
1.5nF								
2.2nF								
3.3nF								
4.7nF								

五、可靠性测试 Reliability Test

项目 Item	技术规格 Technical Specification		测试方法 Test Method and Remarks		
1、容量 Capacitance	I类 Class I	应符合指定的误差级别 Should be within the specified tolerance.	标称容量 Capacitance	测试频率 Measuring Frequency	测试电压 Measuring Voltage
			≤1000pF	1MHz±10%	1.0±0.2Vrms
			>1000 pF	1KHz±10%	
	II类 Class II	应符合指定的误差级别 Should be within the specified tolerance.	测试温度: 25°C±3°C 测试频率: 1KHz±10% 测试电压: 1.0±0.2Vrms Test Temperature: 25°C±3°C Test Frequency: 1KHz±10% Test Voltage: 1.0±0.2Vrms		
2、损耗角正切(DF, tan δ) Dissipation Factor	I类 Class I	DF	标称容量 Capacitance	测试频率 Measuring Frequency	测试电压 Measuring Voltage
		≤0.56%	Cr<5 pF	1MHz±10%	1.0±0.2Vrms
		≤1.5[(150/Cr)+7]×10 ⁻⁴	5pF≤Cr<50 pF	1MHz±10%	
		≤0.15%	50pF≤Cr≤1000 pF	1MHz±10%	
	≤0.15%	>1000 pF	1KHz±10%		
	II类 Class II	X7R	C≤10μF 测试频率: 1KHz±10% 测试电压: 1.0±0.2Vrms Test Frequency: 1KHz±10% Test Voltage: 1.0±0.2Vrms		
		≥50V			
		≤2.5%			



项目 Item	技术规格 Technical Specification		测试方法 Test Method and Remarks										
3、绝缘电阻 (IR) Insulation Resistance	I类 Class I	$C \leq 10 \text{ nF}$, $R_i \geq 50000 \text{ M}\Omega$ $C > 10 \text{ nF}$, $R_i \cdot C_R \geq 500 \text{ S}$	测试电压: $\text{DC}500 \pm 50 \text{ V}$ 测试时间: $60 \pm 5 \text{ 秒}$ 测试湿度: $\leq 75\%$ 测试温度: $25^\circ\text{C} \pm 3^\circ\text{C}$ 测试充放电电流: $\leq 50 \text{ mA}$ Measuring Voltage: $\text{DC}500 \pm 50 \text{ V}$ Duration: $60 \pm 5 \text{ s}$ Test Humidity: $\leq 75\%$ Test Temperature: $25^\circ\text{C} \pm 3^\circ\text{C}$ Test Current: $\leq 50 \text{ mA}$										
	II类 Class II	X7R $C \leq 25 \text{ nF}$, $R_i \geq 10000 \text{ M}\Omega$ $C > 25 \text{ nF}$, $R_i \cdot C_R > 100 \text{ S}$											
4、介质耐电强度 (DWV) Dielectric Withstanding Voltage	无缺陷或异常 No defects or abnormalities		在端子间施加表中的电压 $60 \pm 1 \text{ S}$ 时不应观察到任何故障, 并且充电/放电电流不超过 50 mA No failure should be observed when voltage in the table is applied between the terminations for 60 sec. provided the charge/discharge current is less than 50 mA . <table border="1" style="margin-left: auto; margin-right: auto;"> <tr> <td></td> <td>测量电压</td> </tr> <tr> <td>XA、B</td> <td>DC1075V</td> </tr> <tr> <td>YB、C</td> <td>AC1500V</td> </tr> </table>		测量电压	XA、B	DC1075V	YB、C	AC1500V				
	测量电压												
XA、B	DC1075V												
YB、C	AC1500V												
5、可焊性 Solderability	上锡率应大于 95% 外观: 无可见损伤. At least 95% of the terminal electrode is covered by new solder. Visual Appearance: No visible damage.		将电容在 $80 \sim 120^\circ\text{C}$ 的温度下预热 $10 \sim 30 \text{ 秒}$. Preheating conditions: $80 \text{ to } 120^\circ\text{C}$; $10 \sim 30 \text{ s}$. <table border="1" style="margin-left: auto; margin-right: auto;"> <tr> <td>有铅焊料: (Sn/Pb: 63/37)</td> <td>无铅焊料:</td> </tr> <tr> <td>浸锡温度: $235 \pm 5^\circ\text{C}$</td> <td>浸锡温度: $245 \pm 5^\circ\text{C}$</td> </tr> <tr> <td>浸锡时间: $2 \pm 0.5 \text{ s}$</td> <td>浸锡时间: $2 \pm 0.5 \text{ s}$</td> </tr> <tr> <td>Solder Temperature: $235 \pm 5^\circ\text{C}$</td> <td>Solder Temperature: $245 \pm 5^\circ\text{C}$</td> </tr> <tr> <td>Duration: $2 \pm 0.5 \text{ s}$</td> <td>Duration: $2 \pm 0.5 \text{ s}$</td> </tr> </table>	有铅焊料: (Sn/Pb: 63/37)	无铅焊料:	浸锡温度: $235 \pm 5^\circ\text{C}$	浸锡温度: $245 \pm 5^\circ\text{C}$	浸锡时间: $2 \pm 0.5 \text{ s}$	浸锡时间: $2 \pm 0.5 \text{ s}$	Solder Temperature: $235 \pm 5^\circ\text{C}$	Solder Temperature: $245 \pm 5^\circ\text{C}$	Duration: $2 \pm 0.5 \text{ s}$	Duration: $2 \pm 0.5 \text{ s}$
有铅焊料: (Sn/Pb: 63/37)	无铅焊料:												
浸锡温度: $235 \pm 5^\circ\text{C}$	浸锡温度: $245 \pm 5^\circ\text{C}$												
浸锡时间: $2 \pm 0.5 \text{ s}$	浸锡时间: $2 \pm 0.5 \text{ s}$												
Solder Temperature: $235 \pm 5^\circ\text{C}$	Solder Temperature: $245 \pm 5^\circ\text{C}$												
Duration: $2 \pm 0.5 \text{ s}$	Duration: $2 \pm 0.5 \text{ s}$												
6、耐焊接热 Resistance to Soldering Heat	项目 Item	NPO	X7R										
	$\Delta C/C$	$\leq \pm 2.5\%$ 或 $\pm 0.25 \text{ PF}$, 取较大值 $\leq \pm 2.5\%$ or $\pm 0.25 \text{ PF}$, whichever is larger	$-5 \sim +10\%$										
	DF	同初始标准 Same to initial value.											
	IR	同初始标准 Same to initial value.											
外观: 无可见损伤 上锡率: $\geq 95\%$ Appearance: No visible damage. At least 95% of the terminal electrode is covered by new solder.													
将电容在 $100 \sim 200^\circ\text{C}$ 的温度下预热 $10 \pm 2 \text{ 分钟}$. 浸锡温度: $265 \pm 5^\circ\text{C}$ 浸锡时间: $10 \pm 1 \text{ s}$ 然后取出溶剂清洗干净, 在 10 倍以上的显微镜底下观察. 放置时间: $24 \pm 2 \text{ 小时}$ 放置条件: 室温 Preheating conditions: $100 \text{ to } 200^\circ\text{C}$; $10 \pm 2 \text{ min}$. Solder Temperature: $265 \pm 5^\circ\text{C}$ Duration: $10 \pm 1 \text{ s}$ Clean the capacitor with solvent and examine it with a $10 \times$ (min.) microscope. Recovery Time: $24 \pm 2 \text{ h}$ Recovery condition: Room temperature													

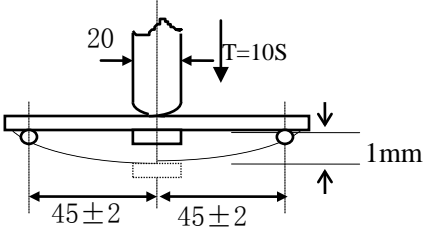

项目 Item	技术规格 Technical Specification	测试方法 Test Method and Remarks																														
7、抗弯曲强度 Resistance to Flexure of Substrate (Bending Strength)	外观：无可见损伤。 Appearance: No visible damage. ΔC/C: 1 类电容：≤3%或±2pF 2 类电容：≤12.5%	试验基板：Al ₂ O ₃ 或 PCB 弯曲深度：1mm 施压速度：1mm/sec. 单位：mm 应在弯曲状态下进行测量。  Test Board: Al ₂ O ₃ or PCB Warp: 1mm Speed: 1mm/sec. Unit: mm The measurement should be made with the board in the bending position.																														
8、温度循环 Temperature Cycle	ΔC/C: I 类：≤±2.5%或±0.25pF， 取两者中最大者 II 类：B：≤±7.5% Class I：≤±2.5% or ±0.25pF, whichever is larger. Class II：B：≤±7.5%	预处理* (2 类)：上限类别温度，1 小时 恢复：24±1h 循环次数：5 次，一个循环分以下 4 步： <table border="1" data-bbox="808 1150 1339 1432"> <thead> <tr> <th>阶段</th> <th>温度 (°C)</th> <th>时间(分钟)</th> </tr> </thead> <tbody> <tr> <td>第 1 步</td> <td>下限温度 (NPO/X7R: -55)</td> <td>30</td> </tr> <tr> <td>第 2 步</td> <td>常温 (+20)</td> <td>2~3</td> </tr> <tr> <td>第 3 步</td> <td>上限温度 (NPO/X7R: +125)</td> <td>30</td> </tr> <tr> <td>第 4 步</td> <td>常温 (+20)</td> <td>2~3</td> </tr> </tbody> </table> 试验后放置 (恢复) 时间：24±2h Preheating conditions: up-category temperature, 1h Recovery time: 24±1h Cycling Times: 5 times, 1 cycle, 4 steps: <table border="1" data-bbox="808 1617 1445 1885"> <thead> <tr> <th>Step</th> <th>Temperature (°C)</th> <th>Time (min.)</th> </tr> </thead> <tbody> <tr> <td>1</td> <td>Low- category temp. (NPO/X7R: -55)</td> <td>30</td> </tr> <tr> <td>2</td> <td>Normal temp. (+20)</td> <td>2~3</td> </tr> <tr> <td>3</td> <td>Up- category temp. (NPO/X7R: +125)</td> <td>30</td> </tr> <tr> <td>4</td> <td>Normal temp. (+20)</td> <td>2~3</td> </tr> </tbody> </table> Recovery time after test: 24±2h	阶段	温度 (°C)	时间(分钟)	第 1 步	下限温度 (NPO/X7R: -55)	30	第 2 步	常温 (+20)	2~3	第 3 步	上限温度 (NPO/X7R: +125)	30	第 4 步	常温 (+20)	2~3	Step	Temperature (°C)	Time (min.)	1	Low- category temp. (NPO/X7R: -55)	30	2	Normal temp. (+20)	2~3	3	Up- category temp. (NPO/X7R: +125)	30	4	Normal temp. (+20)	2~3
阶段	温度 (°C)	时间(分钟)																														
第 1 步	下限温度 (NPO/X7R: -55)	30																														
第 2 步	常温 (+20)	2~3																														
第 3 步	上限温度 (NPO/X7R: +125)	30																														
第 4 步	常温 (+20)	2~3																														
Step	Temperature (°C)	Time (min.)																														
1	Low- category temp. (NPO/X7R: -55)	30																														
2	Normal temp. (+20)	2~3																														
3	Up- category temp. (NPO/X7R: +125)	30																														
4	Normal temp. (+20)	2~3																														



项目 Item	技术规格 Technical Specification		测试方法 Test Method and Remarks
9、湿度负荷 Humidity Loading	Δ C/C	I类: $\leq \pm 2\%$ 或 $\pm 1pF$, 取两者之中较大者 II类: B: $\leq \pm 10\%$ Class I: $\leq \pm 2\%$ or $\pm 1pF$, whichever is larger. Class II: B: $\leq \pm 10\%$	施加电压: 额定电压 温度: $40 \pm 2^\circ C$ 湿度: 90~95%RH 时间: 500 小时 放置条件: 室温 放置时间: 24 小时(I类); 48 小时(II类) Applied Voltage: Rated Voltage Temperature: $40 \pm 2^\circ C$ Humidity: 90~95%RH Duration: 500h Recovery conditions : Room temperature Recovery Time: 24h (Class1) or 48h (Class2)
		DF	
	IR	I类: $R_i \geq 5000\Omega$ 或 $R_i \cdot C_R \geq 50S$ 取两者之中较小者. Class I : $R_i \geq 5000\Omega$ 或 $R_i \cdot C_R \geq 50S$ whichever is smaller.	
		II类: $R_i \geq 1000\Omega$ 或 $R_i \cdot C_R \geq 10S$ 取两者之中较小者. Class II : $R_i \geq 1000\Omega$ 或 $R_i \cdot C_R \geq 10S$ whichever is smaller.	
外观: 无损伤 Appearance: No visible damage.			
10、稳态湿热 Damp heat, steady state	Δ C/C	I类: $\leq \pm 2\%$ 或 $\pm 1pF$, 取两者之中较大者 II类: B: $\leq \pm 10\%$ Class I: $\leq \pm 2\%$ or $\pm 1pF$, whichever is larger. Class II: B: $\leq \pm 10\%$	温度: $40 \pm 2^\circ C$ 湿度: 90~95%RH 时间: 500 小时 放置条件: 室温 放置时间: 24 小时(I类); 48 小时(II类) Temperature: $40 \pm 2^\circ C$ Humidity: 90~95%RH Voltage: 250Vac Duration: 500h Recovery conditions : Room temperature Recovery Time: 24h (Class1) or 48h (Class2)
		DF	
	IR	I类: $R_i \geq 2500\Omega$ 或 $R_i \cdot C_R \geq 25S$ 取两者之中较小者. Class I : $R_i \geq 2500\Omega$ 或 $R_i \cdot C_R \geq 25S$ whichever is smaller.	
		II类: $R_i \geq 1000\Omega$ 或 $R_i \cdot C_R \geq 25S$ 取两者之中较小者. Class II : $R_i \geq 1000\Omega$ 或 $R_i \cdot C_R \geq 25S$ whichever is smaller.	
外观: 无损伤 Visual Appearance: No visible damage.			
11、振动 Vibration	无可见损伤 No visible damage	电容器件安装到 PCB 板上, 试验频率 10~55Hz, 振动幅度 1.5mm, 在 3 个垂直方向上各振动 2 小时, 共 6 小时	
12、端头结合强度 Termination Adhesion	外观无可见损伤 No visible damage.	施加的力: 5N 时间: $10 \pm 1S$ Applied Force: 5N Duration: $10 \pm 1S$	

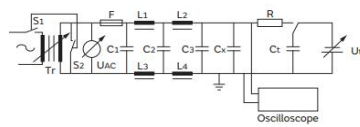
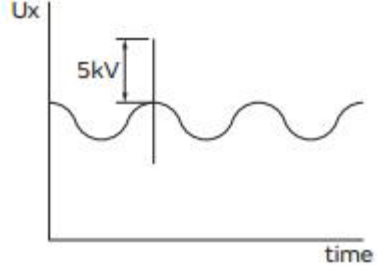

项目 Item	技术规格 Technical Specification	测试方法 Test Method and Remarks
13、阻燃性测试 Passive Flammability	纸巾不被烧起来 The tissue paper shall not ignite.	<p>试验电容器保持在火焰中最有利于燃烧的位置，如附图每个样品只能暴露在火焰中一次。 火焰作用时间：30S The capacitor under test shall be held in the flame in the position which best promotes burning. Each specimen shall only be exposed once to the flame. Time of exposure to flame : 30 s</p> 
14、自燃性测试 Active Flammability	纯棉纱不会燃烧	<p>在产品外部包裹至少一层但不多于两层的纯棉纱，样品经受储能电容器 20 次的放电试验，连续放电之间每次间隔时间应为 5s，最后一次放电，交流电应保持 2 分钟。</p>   <p>C1, C2:1uF ± 10% C3:0.033uF±5% 10kV L1, L2, L3, L4 :1.5mH±20% 16A Ct : 3uF±5% 10Kv R : 100Ω±2% Cx : 样品电容 UAC: UR±5% F : 16A 保险丝 UR : 额定电压 Ut : 施加在储能钽电容器上的电压</p>

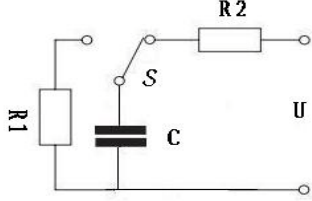

项目 Item	技术规格 Technical Specification		测试方法 Test Method and Remarks								
15、充放电 Charge and discharge	Δ C/C	I类: $\leq \pm 2\%$ 或 $\pm 1\text{pF}$, 取两者之中较大者 II类: B: $\leq \pm 10\%$ Class I: $\leq \pm 2\%$ or $\pm 1\text{pF}$, whichever is larger. Class II: B: $\leq \pm 10\%$	<p>如下图所示安放被测器件 C, 承受 10000 次充放电循环:</p>  <p>充电电压: 额定电压 充放电电流: $\leq 1\text{A}$ As shown in the following figure, the device under test C is placed and subjected to 10000 charge and discharge cycles: Charge voltage: U_r</p> <p>C: capacitor under test R1: current-limiting resistor (discharge) R2: current-limiting resistor (charge) U: charge voltage S: switching device</p>								
	DF	同初始标准 Same to initial value.									
	IR	I类: $R_i \geq 2500\Omega$ 或 $R_i \cdot C_r \geq 25\text{S}$ 取两者之中较小者. Class I: $R_i \geq 2500\Omega$ 或 $R_i \cdot C_r \geq 25\text{S}$ whichever is smaller. II类: $R_i \geq 1000\Omega$ 或 $R_i \cdot C_r \geq 25\text{S}$ 取两者之中较小者. Class II: $R_i \geq 1000\Omega$ 或 $R_i \cdot C_r \geq 25\text{S}$ whichever is smaller.									
	无缺陷或异常 No defects or abnormalities.										
16、脉冲电压 Impulse voltage	无永久性击穿或飞弧。 No permanent breakdown or flashover.		<p>每个电容器应承受 24 次相同极性的脉冲, 脉冲间隔时间不应小于 10S, 脉冲电压峰值如下表:</p> <p>Each capacitor shall withstand 24 pulses of the same polarity, the pulse interval time shall not be less than 10S, and the peak value of pulse voltage like the follow table:</p> <table border="1" data-bbox="862 1404 1382 1581"> <thead> <tr> <th>Code</th> <th>使用时的峰值脉冲电压 kV</th> </tr> </thead> <tbody> <tr> <td>XA</td> <td>4.0</td> </tr> <tr> <td>XB</td> <td>2.5</td> </tr> <tr> <td>YB</td> <td>5</td> </tr> </tbody> </table>	Code	使用时的峰值脉冲电压 kV	XA	4.0	XB	2.5	YB	5
Code	使用时的峰值脉冲电压 kV										
XA	4.0										
XB	2.5										
YB	5										



项目 Item	技术规格 Technical Specification		测试方法 Test Method and Remarks
17、耐久性 Endurance	$\Delta C/C$	I类: $\leq \pm 2\%$ 或 $\pm 1pF$ 取两者之中较大者 II类: B: $\leq \pm 20\%$ Class I: $\leq \pm 2\%$ or $\pm 1pF$, whichever is larger. Class II: B: $\leq \pm 20\%$	脉冲电压试验完成后的一周内进行。 温度: $125^{\circ}C$ (NPO X7R) 时间: 1000 小时 充电电流: 不应超过 50mA 施加电压: XA/XB: 1.25 额定电压 YB: 1.7 额定电压
	DF	≤ 2 倍初始标准 Not more than twice of initial value.	电容器串联一个 $47\Omega \pm 5\%$ 电阻器; 每小时一次将电 压升高至 1000V, 持续时间 0.1s。 放置条件: 室温
	IR	I类: $R_i \geq 4000M\Omega$ 或 $R_i \cdot C_R \geq$ $40S$ 取两者之中较小者。 Class I: $R_i \geq 4000M\Omega$ 或 $R_i \cdot C_R$ $\geq 40S$ whichever is smaller.	放置时间: 24 小时 (I类), 或 48 小时 (II类), This test shall be conducted within one week after the completion of impulse voltage test. Temperature: $125^{\circ}C$ (NPO X7R) Duration: 1000h
		II类: $R_i \geq 2000M\Omega$ 或 $R_i \cdot C_R \geq$ $50S$ 取两者之中较小者。 Class II: $R_i \geq 2000M\Omega$ 或 $R_i \cdot C_R$ $\geq 50S$ whichever is smaller.	Charge/ Discharge Current: 50mA max. Applied Voltage: XA/XB: 1.25 Rated Voltage YB: 1.7 Rated Voltage The capacitor is connected in series with a 47 $\Omega \pm 5\%$ resistor. Raise the voltage to 1000V once an hour for 0.1sec.
外观: 无损伤 Visual Appearance: No visible damage.		Recovery Conditions: Room Temperature Recovery Time: 24h (Class 1), or 48h (Class2)	

六、包装 PACKAGE

● 塑胶卷盘结构 EMBOSSED TAPING

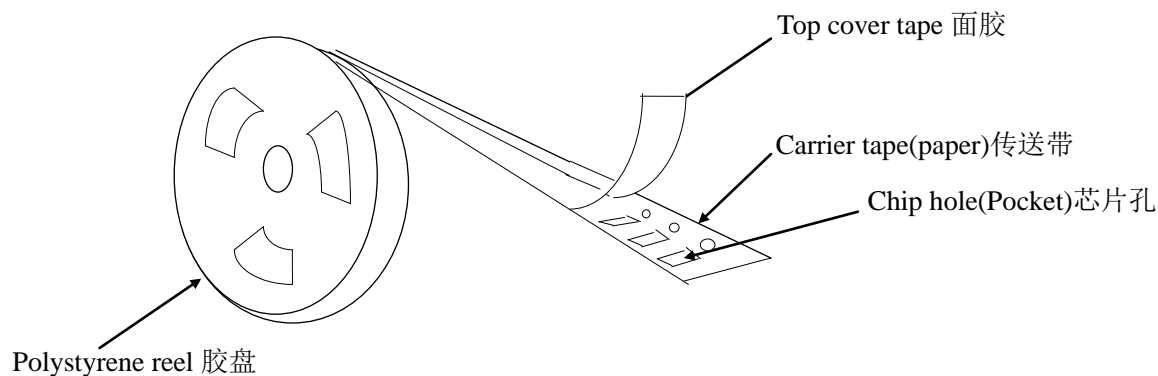



● 塑胶带尺寸结构

Dimensions of embossed taping

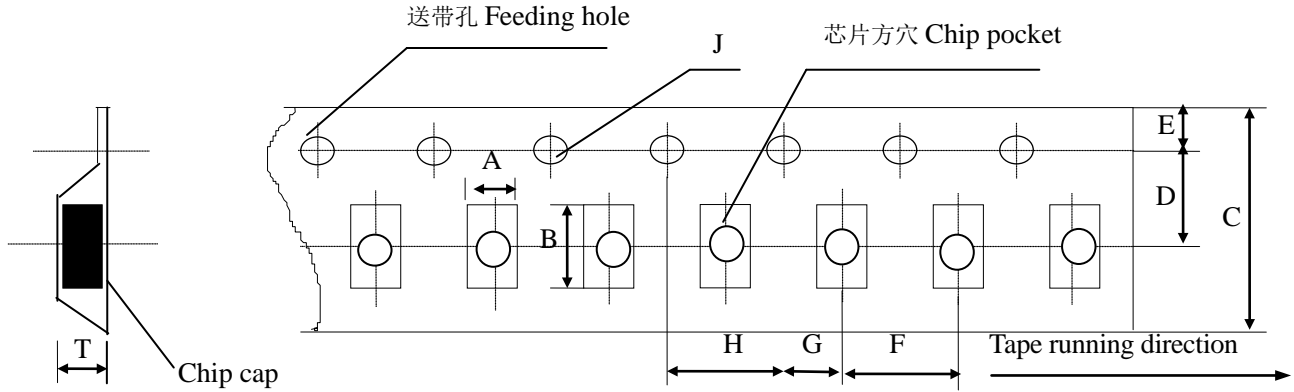

代号 Code 规格 Tape size	A	B	C	D*	E	F	G*	H	J	T
1808	2.20 ± 0.10	4.95 ± 0.10	12.00 ± 0.10	5.50 ± 0.05	1.75 ± 0.10	4.00 ± 0.10	2.00 ± 0.05	4.00 ± 0.10	1.50 -0/+0.10	3.0 Max
1812	3.66 ± 0.10	4.95 ± 0.10	12.00 ± 0.10	5.50 ± 0.05	1.75 ± 0.10	8.00 ± 0.10	2.00 ± 0.05	4.00 ± 0.10	1.55 -0/+0.10	4.0 Max
2211										
2220										

备注：*表示此处对尺寸的要求非常精确。

Note: The place with "*" means where needs exactly dimensions.

● 传送带的前后结构 Structure of leader part and end part of the carrier paper

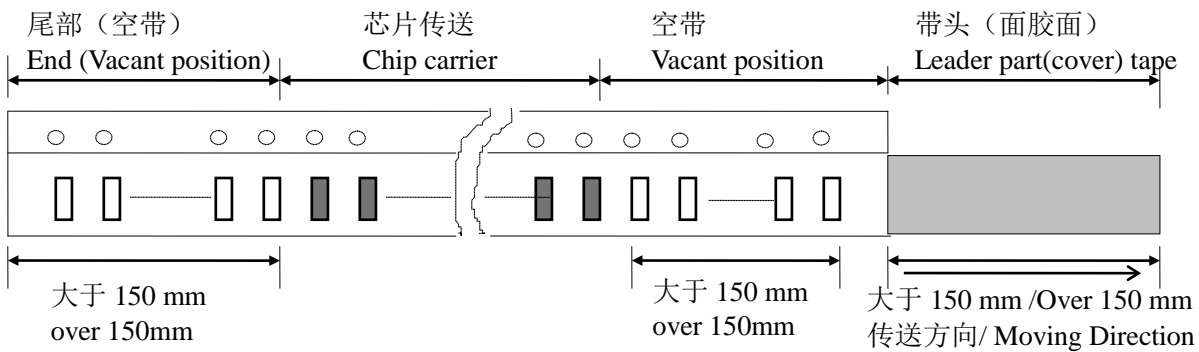



● 卷盘尺寸 Reel Dimensions (unit: mm)

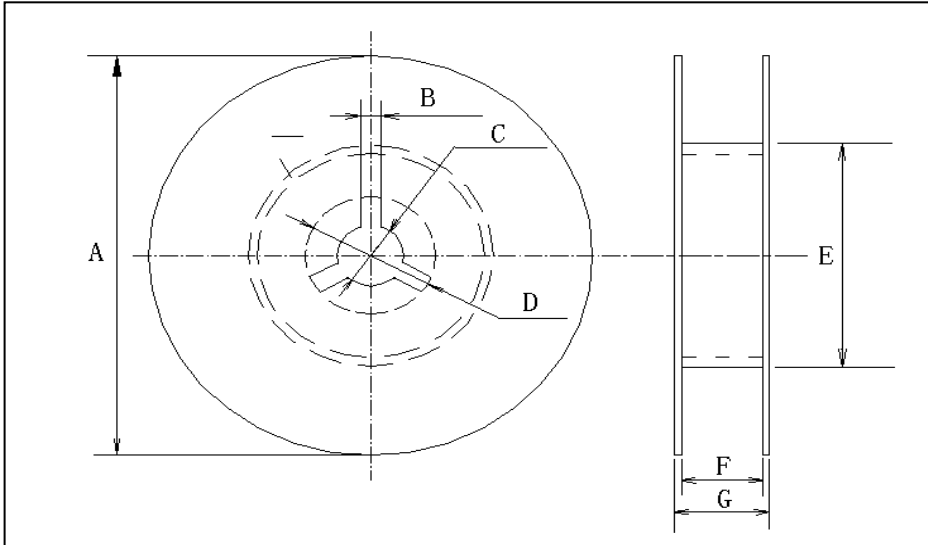

● 尺寸代码 (CODE)

卷盘型号	A	B	C	D	E	F	G
7' REEL	$\phi 178 \pm 2.0$	3.0	$\phi 13 \pm 0.5$	$\phi 21 \pm 0.8$	$\phi 50$ 或更大 $\phi 50$ or more	100 ± 1.5	12max
13' REEL	$\phi 330 \pm 2.0$	3.0	$\phi 13 \pm 0.5$	$\phi 21 \pm 0.8$	$\phi 50$ 或更大 $\phi 50$ or more	100 ± 1.5	12max

● 关于卷带的说明 Taping specification

※ 面胶剥离强度 Top tape peeling strength

(a) 纸带 Paper Taping

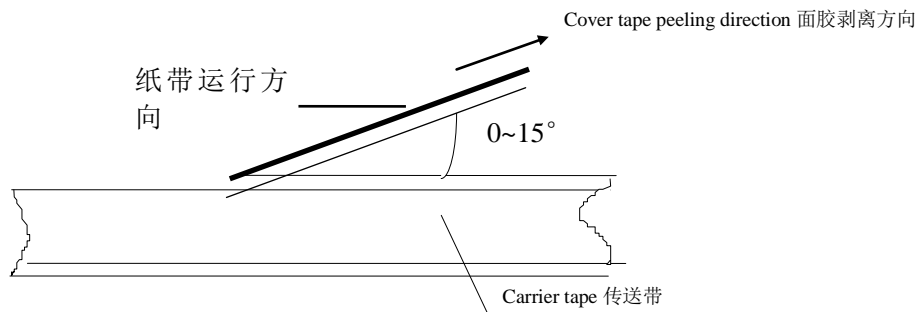



(b) 塑料胶盘 Embossed Taping

Cover tape peeling direction 面胶剥离方向

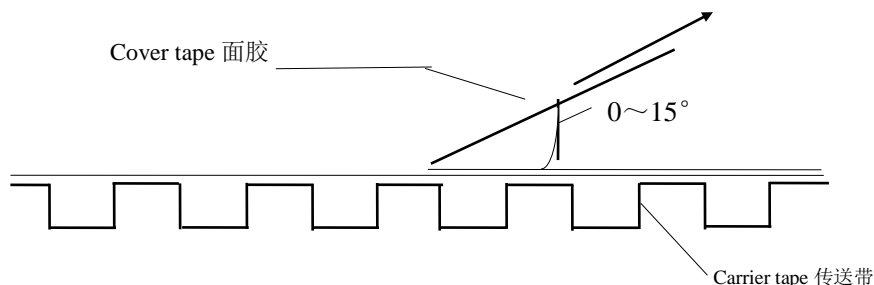

标准: $0.1N < \text{剥离强度} < 0.7N$

在剥离时, 纸带不能有纸碎, 也不能粘在底、面胶上。

Standard: $0.1N < \text{peeling strength} < 0.7N$

No paper dirty remains on the scotch when peeling, and sticks to top and bottom tape.

● 塑料盒散包装 Bulk Case Package

单位 (unit) :mm

Symbol	A	B	T	C	D	E
Dimension	6.80 ± 0.10	8.80 ± 1.00	12.00 ± 0.10	$15.00 + 0.10 / -0$	$2.00 + 0 / -0.10$	4.70 ± 0.10
Symbol	F	W	G	H	L	I
Dimension	$31.50 + 0.20 / -0$	$36.00 + 0 / -0.20$	19.00 ± 0.35	7.00 ± 0.35	110.00 ± 0.70	5.00 ± 0.35

● 包装数量 Packing Quantity

尺寸 (SIZE)	包装形式和数量 (PACKAGE STYLE & QUANTITY) unit: pcs			
	纸带卷盘 (PT)	胶带卷盘 (ET)	塑料盒散装 (BC)	一般散装 (BP)
1808	-----	2000	-----	2000
1812	-----	T ≤ 1.85mm 1000 T > 1.85mm 500	-----	2000

注意: 包装的形式和数量可根据客户的要求来定。

Note: We can choose packing style and quantity can be according to the customer's requirement.



●外包装 Outer packing

小包装 The first package

Quantity: 10 reels

数量: 10 卷

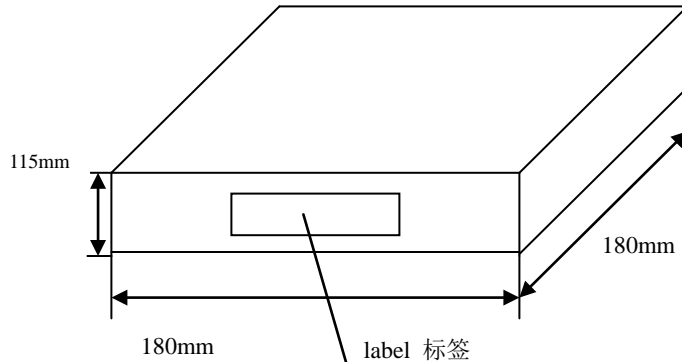

PART No 型号规格
QUANTITY 数量
DATE 日期

大包装 The second package

Quantity: 6 cases

数量: 6 盒

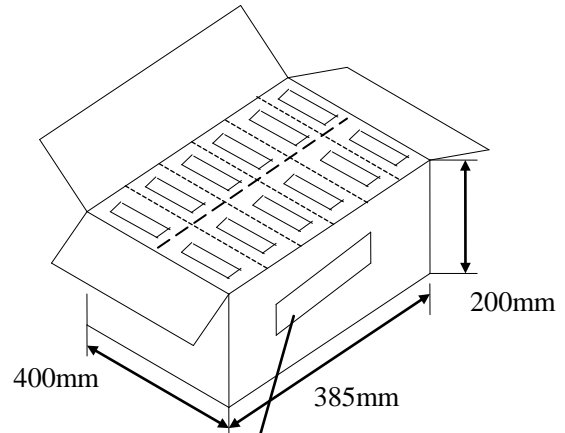

Production name 产品名称
Quantity 数量
Weight 重量

七、储存方法 Storage Methods

确保芯片可焊性良好的贮存期限为 12 个月(在包装好已交付的情况下)。

The guaranteed period for solderability is 12 months (Under deliver package condition).

储存条件/Storage conditions:

储存温度/Temperature 5~40℃

储存相对湿度/Relative Humidity 20~70%

八、使用前的注意事项 Precautions For Use

多层片式瓷介电容器(MLCC)在短路或开路的电路中都有可能失效,在超出本承认书或相关说明书中所述使用频率的恶劣工作环境,或外界机械力超压作用下,电容芯片都有可能着火、燃烧甚至爆炸,所以在使用的时候,首先应考虑按本承认书的有关说明来进行,如有不明之处,请联系我们技术部、品管部或生产部。

The Multi-layer Ceramic Capacitors (MLCC) may fail in a short circuit modern in an open circuit mode when subjected to severe conditions of electrical environment and / or mechanical stress beyond the specified “rating” and specified “conditions” in the specification, which will result in burn out, flaming or glowing in the worst case. Following “precautions for “safety” and Application Notes shall be taken in your major consideration. If you have a question about the precautions for handling, please contact our engineering section or factory.



1. 焊接的条件与相关图表 Soldering Profile

为避免因温度的突然变化而引起的芯片开裂或局部爆炸的现象发生,请按有关温度曲线图表来进行。(请参考附页中的图表)

To avoid the crack problem by sudden temperature change, follow the temperature profile in the adjacent graph (refer to the graph in the enclosure page).

2. 手工焊接 Manual Soldering

手工焊接很容易因为芯片局部受热不均而引起瓷体微裂或局部爆炸的现象,在焊接时,如果操作者不小心,会使烙铁头直接同电容芯片的瓷体部分接触,这样很容易使电容芯片因热冲击而受损或出现其他意外.因此,使用电烙铁手工焊接时应仔细操作,并对电烙铁的尖端的选择和尖端温度控制应多加小心.

Manual soldering can pose a great risk of creating thermal cracks in capacitors. The hot soldering iron tip comes into direct contact with the end terminations, and operator's careless may cause the tip of the soldering iron to come into direct contact with the ceramic body of the capacitor. Therefore the soldering iron must be handled carefully, and pay much attention to the selection of the soldering iron tip and temperature contact of the tip.

3. 适量的焊料 Optimum Solder Amount for Reflow Soldering

焊料过多
Too much solder

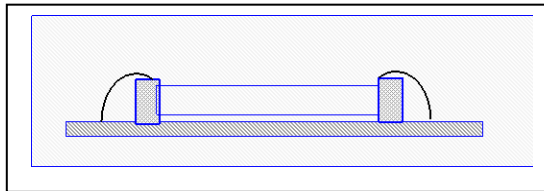

这样会因端头压力过大而
可能引起芯片受损
Cracks tend to occur due to large stress.

焊料太少
Not enough solder

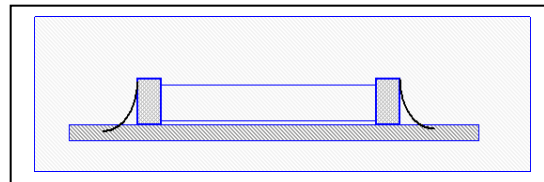

固定力量不足,可能会引起
电容芯片与线路接触不良
Weak holding force may cause bad
connection between the capacitor and PCB.

4. 推荐焊料用量 Recommended Soldering amounts

4.1 回流焊接的最佳焊料用量

The optimal solder fillet amounts for re-flow soldering

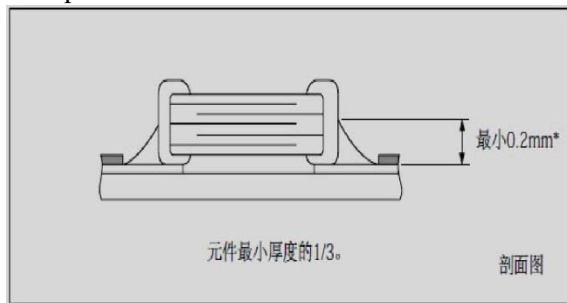

4.2 波峰焊接的最佳焊料用量

The optimal solder fillet amounts for wave soldering

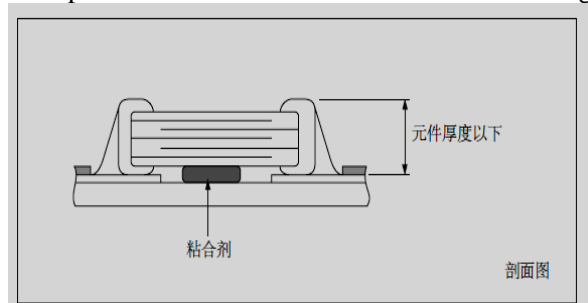



4.3使用烙铁返修时的最佳焊料量

The optimal solder fillet amounts for reworking by using soldering iron

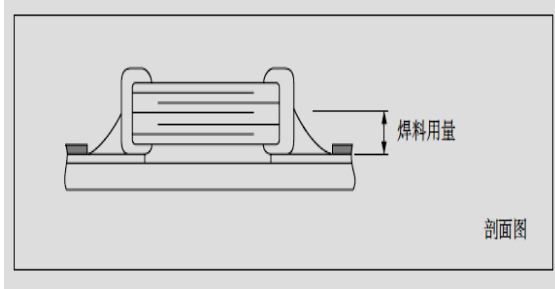

九、推荐焊接方式 Recommended Soldering Method

规格尺寸 Size	温度特性 Temperature Characteristics	额定电压 Rated Voltage	容量范围 Capacitance	焊接方式 Soldering Method
≥1210	NPO	/	/	R
	X7R/X5R/X7S/X6S	/	/	R

十、推荐焊接温度曲线图 The temperature profile for soldering

回流焊接 (Re-flow soldering)

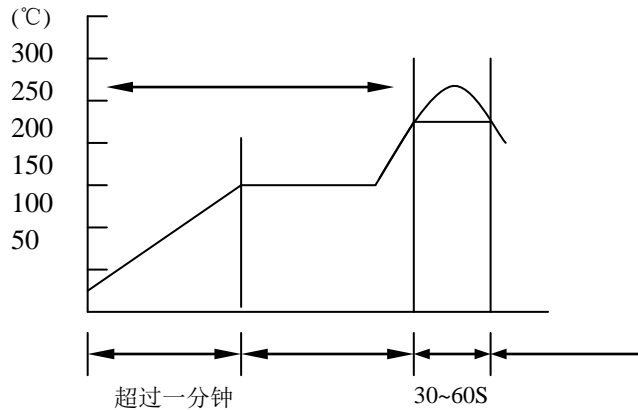

	Pb-Sn 焊接 Pb-Sn soldering	无铅焊接 Lead-free soldering
尖峰温度 Peak temperature	230°C~250°C	240°C~260°C

在预热时, 请将焊接温度与芯片表面温度之间的温差维持在 $T \leq 150^{\circ}\text{C}$ 。

While in preheating, please keep the temperature difference between soldering temperature and surface temperature of chips as: $T \leq 150^{\circ}\text{C}$.



手工焊接 (Hand soldering)

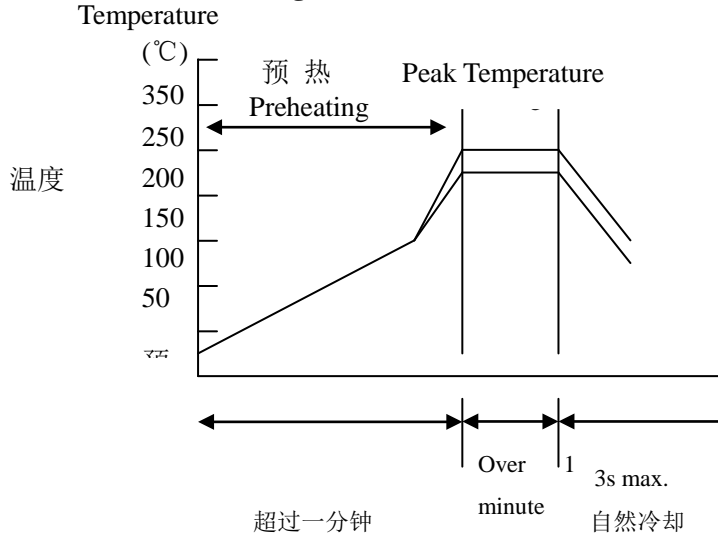

条件 Conditions:

预热 Preheating	烙铁头温度 Temperature of soldering iron head	烙铁功率 Power of soldering iron	烙铁头直径 Diameter of soldering iron head	焊接时间 Soldering time	锡膏量 Solder paste amount	限制条件 Restricted conditions
$\Delta \leq 130^{\circ}\text{C}$	最高 350°C Highest temperature: 350°C	最大 20W 20W at the highest	建议 1mm 1mm recommended	最长 3s 3s at the longest	$\leq 1/2$ 芯片厚度 $\leq 1/2$ chip thickness	请勿使用烙铁头直接接触陶瓷元件 Please avoid the direct contact between soldering iron head and ceramic components

※以最新版本的内容为准

X-ON Electronics

Largest Supplier of Electrical and Electronic Components

Click to view similar products for [Multilayer Ceramic Capacitors MLCC - SMD/SMT](#) category:

Click to view products by [Fenghua Advanced](#) manufacturer:

Other Similar products are found below :

[M39014/02-1218V](#) [M39014/02-1225V](#) [M39014/22-0631](#) [D55342E07B523DR-T/R](#) [NCA1206X7R103K50TRPF](#) [NCA1206X7R104K16TRPF](#)
[NIN-FC2R7JTRF](#) [NMC0402NPO220J50TRPF](#) [NMC0402X5R105K6.3TRPF](#) [NMC0402X5R224K6.3TRPF](#) [NMC0402X7R103J25TRPF](#)
[NMC0402X7R392K50TRPF](#) [NMC0603NPO201J50TRPF](#) [NMC0603X7R333K16TRPF](#) [NMC0805NPO820J50TRPF](#)
[NMC0805X7R224K16TRPLPF](#) [NMC1206X7R102K50TRPF](#) [NMC1206X7R106K10TRPLPF](#) [NMC1206X7R475K10TRPLPF](#) [NMC-](#)
[Q0402NPO8R2D200TRPF](#) [C1608C0G2A221J](#) [C1608X7R1E334K](#) [C2012C0G2A472J](#) [2220J2K00562KXT](#) [CDR33BX104AKUR](#)
[CDR33BX683AKUS](#) [CGA3E1X7R1C684K](#) [CL10C0R8BB8ANNC](#) [C1005X5R0G225M](#) [C2012X7R2E223K](#) [C3216C0G2J272J](#)
[D55342E07B35E7R-T/R](#) [NMC0402X7R562J25TRPF](#) [NMC0603NPO102J25TRPF](#) [NMC1206X7R332K50TRPF](#) [726632-1](#)
[CGA6M3X7R1H225K](#) [CGA5L2X7R2A105K](#) [CGA3E2X8R1H223K](#) [CDR33BX823AKUR\M500](#) [CDR35BX474AKUR\M500](#)
[CDR35BX104BKUR\M500](#) [69995D](#) [NMC0201X5R473K6.3TRPF](#) [NMC0201X7R221K25TRPF](#) [NMC0402X5R105K10TRPF](#)
[NMC0402X5R224K10TRPF](#) [NMC0603X7R104J25TRPF](#) [NMC0603X7R223K25TRPF](#) [NMC0805NPO100J50TRPF](#)