



# 承认书

## APPROVAL SHEET

客户名称:

南京南山半导体

Customer

产品名称:

电感器

Part Name

Inductor

客户料号:

Customer Part No.

产品规格:

VLU0608-203KB

Specification

规格书编号

VLU0608-YH180164

Document No.

版本号:

24.01

Version No.

日期:

2024-2-26

DATE

制造 Manufacturer			客户 Customer		
拟制 Draft by	审核 Checked by	确认 Approve by	检验 Check by	审核 Checked by	批准 Approval by
张满群	黄美艳	张惠霞			

承认书专用章



履历表 Resume

版本 Version No.	修改明细 Modify Details	日期 Date
24.01	首次发行 Initial issue	2024-1-3



序号 No.	目 录 TABLE OF CONTENTS
1	概述 Summary
2	型号规格表示办法 How To Order
3	结构及尺寸 Structure And Dimensions
4	材料清单 Material list
5	电气性能 Performance Specification
6	工作温度范围 Operation temperature
7	可靠性试验项目 Reliability Testing Items
8	包装 Packing
9	推荐焊接条件 Recommend Soldering Conditions
10	贮存方法 Storage Methods
11	使用注意事项 Precautions For Use



## 1. 概述 Summary

除非另有规定，测量和测试的大气条件的标准范围如下：环境温度 15 °C 至 35 °C 相对湿度 25% 至 85%，大气压 86 kPa to 106 kPa。

对结果有任何疑问的，应当在下列范围内进行测量：环境温度 20 °C ± 2 °C 相对湿度 60% 至 70%，大气压 86 kPa to 106 kPa。

Unless otherwise specified, the standard range of atmospheric conditions for measurements and tests are as follows: ambient temperature: 15°C to 35°C relative humidity 25% to 85%.air pressure 86kPa to 106kPa.

If there is any doubt about the results, measurement shall be made within the following limits: ambient temperature: 20 °C ± 2 °C relative humidity 60% to 70%.air pressure 86kPa to 106kPa.

## 2. 型号规格表示办法 How To Order

VLU    0608    -    3R3    □    B    □□□  
①            ②                            ③            ④            ⑤            ⑥

① 产品代号，Product symbol

② 尺寸规格，Dimension

③ 电感量标称值，Inductance

④ 电感量公差代码，Tolerance code, N ±30%,M ±20%,K ±10%

⑤ 包装代码，T-编带盒盘；B-散装，Packing code: T-Tape & box；B-Bulk

⑥ 标准代码，空缺-标准品，标示-定制品，

Standard code, Vacant-Standard product, Indicate-custom product



### 3. 结构及尺寸 Structure And Dimensions

单位 Unit: mm

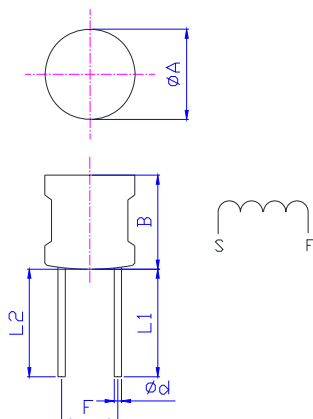

1. 套管包裹与本体顶部齐平;
2. 点环氧树脂固定引脚

A	B	d	F	L1	L2
8.0MAX	11.0MAX	0.60±0.1	3.0±0.5	15±2.0	15±2.0

### 4. 材料清单 Material list:

No.	组件 Component	材料 Material	型号规格 Part No.	UL 档案号码 UL file No.
1	磁芯 Core	镍锌铁氧体 Ni-Zn Ferrite	SR53 DRW6*8 FSO or equivalent	不适用 Not Applicable
2	线材 Wire	漆包线 Enameled wire	2UEW, $\Phi 0.07\text{mm}$ , 155°C, 832.5Ts(ref.)	E194410
3	套管 Tube	热缩套管 Heat Shrinkable Tube	UL $\Phi 7.0\text{ mm}$	E180908
4	引脚 PINS	镀锡铜包钢线 CP line	0.60mm	不适用 Not Applicable
5	粘合剂 Adhesive	环氧树脂 Epoxy	FK661-506, H907-HF or equivalent	不适用 Not Applicable

### 5. 电气性能 Performance Specification

项目 Item	符号	标准 Spec.	测试条件 Test condition	测试仪器 Test instrument
电感量 Inductance	L	20mH±10%	1KHz, 1.0V	MICOTEST 6377+6220 or equivalent
直流电阻 Direct-current Resistance	DCR	58Ω MAX	at25°C	CH3205AC or equivalent
饱和电流 Saturation current	Isat	0.01A $ \Delta L/L  \leq 10\%$	1KHz, 1V	MICOTEST 6377+6220 or equivalent



6. 工作温度范围(包含元件自身发热)Operation temperature (Including self-heating temperature rise.) -25~+105℃。

7. 可靠性试验项目 Reliability Testing Items

序号	项目	要求	试验方法及备注
1	可焊性 Solderability	引脚上锡面积≥95% Lead Tin coverage ≥95%	在 245±5℃熔融的焊锡中浸置 2.5s±0.5s Dip pads in flux and dip in solder pot at 235±5℃ for 2.5 s±0.5 seconds.
2	引出端强度 Lead electrode strength	磁芯外径>5mm 拉力≥3.0Kg 磁芯外径≤5mm 拉力≥2.0Kg Core outer D>5mm Pull≥3.0Kg Core outer D≤5mm pull≥2.0Kg	使用拉力计测试引出端最大拉力 Use the pull scale to test the maximum pull of the lead
3	耐焊接热 Resistance to Soldering Heat	1. 外观无明显损伤 2. 电感量变化率: $-10\% \leq \Delta L/L \leq 10\%$ 1.No visible mechanical damage. 2. Inductance change: $-10\% \leq \Delta L/L \leq 10\%$	将元件浸入锡炉内, 浸置到锡面平齐产品本体最低点(即平齐磁芯底部端面或套管底部端面), 焊锡温度为 260℃±5℃, 浸置时间为 10s±1s Solder oven Temperature: 260℃±5℃ Immersion time 10s±1s
4	叠加电流 superimposed current	电感量变化符合承认书中规定的要求 Inductance change meet the requirements of approve sheet	施加承认书中规定的电流(若无叠加电流要求则不做叠加电流试验) Applied the current as required in the approve sheet.
5	恒定湿热 Biased humidity	1.外观无明显损伤 2.电感量变化率: $-10\% \leq \Delta L/L \leq 10\%$ 1.No visible mechanical damage. 2. Inductance change: $-10\% \leq \Delta L/L \leq 10\%$	元件置于恒温、恒湿的试验箱中, 按以下条件试验: 温度: 60℃±2℃ 相对湿度: 90%~95% RH 试验时间: 500 h±2 h 试验完成后, 取出元件置于常温、常湿环境中放置 24 h±2 h。 Place the components in box with constant temp and humidity conditions: Temp: 60℃±2℃ Relative Humidity: 90%~95% RH Duration: 500 h±2 h measure at 24 h±2 h after test conclusion.



6	温度冲击 Shock	1.外观无明显损伤 2.电感量变化率: $-10\% \leq \Delta L/L \leq 10\%$ 1.No visible mechanical damage. 2. Inductance change: $-10\% \leq \Delta L/L \leq 10\%$	+125°C环境 30min ↔ -40°C环境 30min, 循环 32 次, 转换时间<5min, 循环结束后常温下放置 24h±2h。 Cycling 32 times from +125°C of 30min ↔ -40°C of 30min, transition time <5min, then place at room temperature for 24h±2h.
7	高温负载 (工作寿命) Hi-Temp (Operation life)	1.外观无明显损伤 2.电感量变化率: $-10\% \leq \Delta L/L \leq 10\%$ 1.No visible mechanical damage. 2. Inductance change: $-10\% \leq \Delta L/L \leq 10\%$	元件置于老化试验箱中, 按以下条件试验: 温度: 85°C±2°C 施加额定的直流电流 试验时间: 1000 h 试验完成后, 取出元件置于常温、常湿环境中放置 24 h±2 h。 Place the components in the aging box: Temp: 85°C±2°C Apply current Duration: 1000 h measure at 24 h±2 h after test conclusion.
8	高温贮存 Hi-Temp storage	1.外观无明显损伤 2.电感量变化率: $-10\% \leq \Delta L/L \leq 10\%$ 1.No visible mechanical damage. 2. Inductance change: $-10\% \leq \Delta L/L \leq 10\%$	元件置于温度+125°C±2°C环境中存放 96 h±2 h, 试验完成后, 取出元件置于常温、常湿环境中放置 24 h±2 h。 Place the components under +125°C±2°C conditions for 96 h±2 h, measure at 24 h±2 h after test conclusion.
9	低温贮存 Low-Temp storage	1.外观无明显损伤 2.电感量变化率: $-10\% \leq \Delta L/L \leq 10\%$ 1.No visible mechanical damage. 2. Inductance change: $-10\% \leq \Delta L/L \leq 10\%$	元件置于温度-40°C±2°C的环境中存放 96 h±2 h, 试验完成后, 取出元件置于常温、常湿环境中放置 24h±2 h。Place the components under -40°C±2°C conditions for 96h±2h, measure at 24h±2h after test conclusion.
10	跌落 Drop	1.外观无异常 2.电气性能符合要求 1. visible damage 2.ectrical performance meets the requirements	条件: 1m 高度自由落下, 3 次水泥地。 Condition: Drop from 1mH to cement floor (3 times)
11	振动 Vibration	1.外观无异常 2.电气性能符合要求 1. No visible damage 2. Electrical performance meets the requirements	振动频率为 10Hz~55Hz, 振动的位移峰值振幅为 1.5mm, X、Y、Z 方向各振动 2 小时, 共 6 小时。 Vibration freq 10Hz~55Hz, The displacement peak amplitude of the vibration was 1.5mm, each X、Y、Z mutually perpendicular directions vibrates 2h, total 6h.



## 8. 包装 Packing

包装方式	标签格式 (仅供参考)	包装要求
		500PCS/袋 500PCS/Bag 5 袋/盒 5Bags/Box 包装袋尺寸: 150*210mm Bag Dimension: 150*210mm 纸盒尺寸: 245*195*80mm Box Dimension: 245*195*80mm
		5 盒/箱 5 Box/Carton 总计: 5 盒*4 袋*500PCS/箱 =10000PCS Total: 5Box*4ags*500PCS/Carton =10000PCS/Carton 箱子尺寸: 437*257*215mm Carton Dimension : 437*257*215mm

## 9. 推荐焊接条件 Recommend Soldering Conditions

### 9.1 本产品建议使用波峰焊接法。

Applicable soldering process to the products is reflow soldering. 接曲线 Soldering Profile

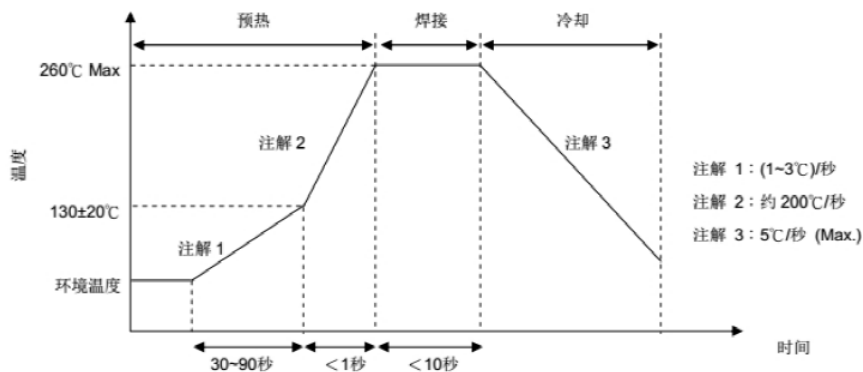





## 10. 贮存方法 Storage Methods

### 10.1 存储期限 Storage Period

为保证端子电极的焊接特性和包装材料处于良好状态，请于本公司发货后 6 个月内使用本产品。同时，由于端子电极的焊接特性会随时间发生变化，如果贮存时间超过 6 个月，请首先确认其焊接特性后再安装使用。

To maintain the solderability of terminal electrodes and to keep the packing material in good condition, product should be used within 6 months from the time of delivery. And the solderability of products electrodes may decrease as time passes, so in case of storage over 6 months, solderability shall be checked before actual usage.

### 10.2 存储条件 Storage Conditions

(1) 存放货物的仓库应满足以下条件 Store products in a warehouse in compliance with the following condition:

温度(Temperature): -5 ~ +30°C                      相对湿度(Humidity): 30~70%RH

(2) 不要使产品遭受温度和湿度的快速变化。

Do not subject products to rapid changes in temperature and humidity.

(3) 不要将产品存放在化学环境中，如硫酸气体或碱性气体中，否则会降低电极端子的焊接特性和使电感器腐蚀。

Do not store the products in chemical atmosphere such as one containing sulfurous acid gas or alkaline gas, that will causes poor solderability and corrosion of inductors.

(4) 为了避免受潮气、灰尘等物质的影响，产品应保管于货架上。

Store products on pallets to protect from humidity, dust, etc

(5) 产品应避免热冲击、振动以及直接光照等等。

Avoid heat shock, vibration, direct sunlight, etc.

## 11. 使用注意事项 Precautions For Use

11.1 本公司产品适用于 AV 设备、OA 设备、家电、信息服务等一般电子设备中。

Our products are designed and promoted for use in general electronic devices such as audio-video equipment, office automation equipment, home appliance and information service.

11.2 当本公司的产品使用在一般电子设备以外的领域时，对于此所引发的设备失效我司将不承担任何法律责任。

In case of using the product for the purpose other than general electronics devices, we shall not be held liable for any dysfunctions in or damage to the equipment with which the product is used.

11.3 本承认书只保证我司产品作为一个单体时的质量情况，当我司产品被安装到贵司产品上时，请贵司对使用在贵司电路上的产品情况进行了有效评价和确认。

Our specification limits the quality of the component as a single unit. Please ensure the component is thoroughly evaluated in your application circuit.

11.3 不要对产品施加过大的振动或机械冲击；

Do not apply excessive vibration or mechanical shock to products.

11.4 为防止断线，请不要使用锋利的物体接触线圈，如镊子；

Do not touch wire with sharp objects such as tweezers to prevent wire breakage.

11.5 在产品贴装时不要使用过大的压力，避免磁芯断裂。

Do not apply excessive stress to products mounted on boards to prevent core breakage.  
Vibration Freq 10Hz ~ 55Hz, The displacement peak amplitude of the vibration was 1.5mm, each of X、Y、Z mutually perpendicular directions vibrates 2h ,total 6h.

## X-ON Electronics

Largest Supplier of Electrical and Electronic Components

*Click to view similar products for [Fixed Inductors](#) category:*

*Click to view products by [Fenghua Advanced](#) manufacturer:*

Other Similar products are found below :

[CR32NP-100KC](#) [70F224AI](#) [MHQ1005P10NJ](#) [MHQ1005P1N0S](#) [MHQ1005P2N4S](#) [MHQ1005P3N6S](#) [MHQ1005P5N1S](#) [MHQ1005P8N2J](#)  
[PE-53601NL](#) [PE-53602NL](#) [PG0936.113NLT](#) [9220-20](#) [9310-16](#) [PM06-2N7](#) [PM06-39NJ](#) [A01TK](#) [1206CS-471XJ](#) [HC2-R47-R](#) [HC8-1R2-R](#)  
[HCF1305-3R3-R](#) [1206CS-151XG](#) [RCH664NP-4R7M](#) [RCP1317NP-391L](#) [DH2280-4R7M](#) [DS1608C-106](#) [B10TJ](#) [B82498B3101J000](#) [ELJ-](#)  
[RE27NJF2](#) [1812CS-153XJ](#) [1812CS-183XJ](#) [1812CS-223XJ](#) [1812LS-104XJ](#) [1812LS-105XJ](#) [1812LS-124XJ](#) [1812LS-154XJ](#) [1812LS-223XJ](#)  
[1812LS-224XJ](#) [1812LS-563XJ](#) [1812LS-683XJ](#) [1812LS-824XJ](#) [NIN-FB101JTR110F](#) [NIN-FB471JTR62F](#) [NIN-FC1R5JTR220F](#) [NIN-](#)  
[HCR15JTRF](#) [NIN-HCR33JTRF](#) [NIN-HDR22JTRF](#) [NIN-HDR82JTRF](#) [NIN-HK2N7STRF](#) [NIN-PA150KTR370F](#) [NIN-PB100KTR550F](#)