



承认书

APPROVAL SHEET

客户名称:

Customer

产品名称:

Part Name

客户料号:

Customer Part No.

产品规格:

Specification

规格书编号

Document No.

版本号:

Version No.

日期:

DATE

电感器

Inductor

VLU0608-3R3MB

VLU0608-YH160841

01

2017-5-19

制造 Manufacturer			客户 Customer		
拟制 Draft by	审核 Checked by	确认 Approve by	检验 Check by	审核 Checked by	批准 Approval by
黄美艳	谭新霖	冯东梅			





序号 No.	目 录 TABLE OF CONTENTS
1	概述 Summary
2	型号规格表示办法 How To Order
3	结构及尺寸 Structure And Dimensions
4	材料清单 Material list
5	电气性能 Performance Specification
6	工作温度范围 Operation temperature
7	贮存方法 Storage Methods
8	使用注意事项 Precautions For Use



1. 概述 Summary

除非另有规定，测量和测试的大气条件的标准范围如下：环境温度 15 °C 至 35 °C 相对湿度 25% 至 85%，大气压 86 kPa to 106 kPa。

对结果有任何疑问的，应当在下列范围内进行测量：环境温度 20 °C ± 2 °C 相对湿度 60% 至 70%，大气压 86 kPa to 106 kPa。

Unless otherwise specified, the standard range of atmospheric conditions for measurements and tests are as follows: ambient temperature: 15°C to 35°C relative humidity 25% to 85%.air pressure 86kPa to 106kPa.

If there is any doubt about the results, measurement shall be made within the following limits: ambient temperature: 20 °C ± 2 °C relative humidity 60% to 70%.air pressure 86kPa to 106kPa.

2. 型号规格表示办法 How To Order

VLU 0608 - 3R3 □ B □□□
① ② ③ ④ ⑤ ⑥

① 产品代号，Product symbol

② 尺寸规格，Dimension

③ 电感量标称值，Inductance

④ 电感量公差代码，Tolerance code, N ±30%,M ±20%,K ±10%

⑤ 包装代码，T-编带盒盘；B-散装，Packing code: T-Tape & box; B-Bulk

⑥ 标准代码，空缺-标准品，标示-定制品，

Standard code, Vacant-Standard product, Indicate-custom product



3. 结构及尺寸 Structure And Dimensions

单位 Unit: mm

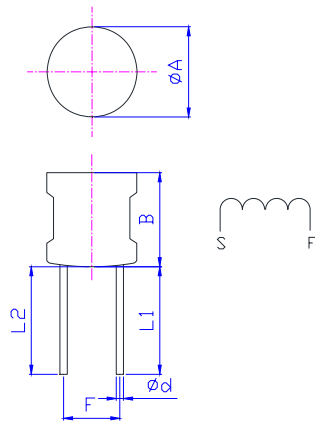

1. 套管包裹与本体顶部齐平;

A	B	d	F	L1	L2
8.0 MAX	11.0MAX	0.60±0.1	3.0 ± 0.3	15±2.0	15±2.0

4. 材料清单 Material list:

No.	组件 Component	材料 Material	型号规格 Part No.	UL 档案号码 UL file No.
1	磁芯 Core	镍锌铁氧体 Ni-Zn Ferrite	SR53 DRW6*8 FSO C3.0 E4.0 P3.0 or equivalent	不适用 Not Applicable
2	线材 Wire	漆包 Enameled wire	2UEW, $\phi 0.45\text{mm}$, 155℃, 10.5Ts(ref.)	E194410
3	套管 Tube	热缩套管 Heat Shrinkable Tube	UL $\phi 7.0$ mm	E180908
4	引脚 PINS	镀锡铜包钢线 CP line	0.60mm	不适用 Not Applicable

5. 电气性能 Performance Specification

项目 Item	符号	标准 Spec.	测试条件 Test condition	测试仪器 Test instrument
电感量 Inductance	L	3.3 μH ±20%	1KHz, 1.0V	MICOTEST 6377+6220 or equivalent
直流电阻 Direct-current Resistance	DCR	30m Ω MAX	at25℃	CH3205AC or equivalent
饱和电流 Saturation current	Isat	3.5A $ \Delta L/L \leq 10\%$	1KHz, 1V	MICOTEST 6377+6220 or equivalent
温升电流 Heat Rating Current	Irms	3.2A $\Delta T < 40^\circ\text{C}$	at25℃	MICOTEST 6377+6220 Thermometer TES-1312A or equivalent

6. 工作温度范围(包含元件自身发热)Operation temperature (Including self-heating temperature rise.) -25~+85℃。

7. 贮存方法 Storage Methods



7.1 存储期限 Storage Period

为保证端子电极的焊接特性和包装材料处于良好状态，请于本公司发货后 6 个月内使用本产品。同时，由于端子电极的焊接特性会随时间发生变化，如果贮存时间超过 6 个月，请首先确认其焊接特性后再安装使用。

To maintain the solderability of terminal electrodes and to keep the packing material in good condition, product should be used within 6 months from the time of delivery. And the solderability of products electrodes may decrease as time passes, so in case of storage over 6 months, solderability shall be checked before actual usage.

7.2 存储条件 Storage Conditions

(1)存放货物的仓库应满足以下条件 Store products in a warehouse in compliance with the following condition:

条件 Conditions	元件含包装物 Packing status	元件自身 Component itself
温度 Temperature	-25~+40℃	-25~+85℃
湿度 Humidity	30~70%RH	30~70%RH

(2)不要使产品遭受温度和湿度的快速变化。

Do not subject products to rapid changes in temperature and humidity.

(3)不要将产品存放在化学环境中，如硫酸气体或碱性气体中，否则会降低电极端子的焊接特性和使电感器腐蚀。

Do not store the products in chemical atmosphere such as one containing sulfurous acid gas or alkaline gas, that will causes poor solderability and corrosion of inductors.

(4)为了避免受潮气、灰尘等物质的影响，产品应保管于货架上。

Store products on pallets to protect from humidity, dust, etc

(5)产品应避免热冲击、振动以及直接光照等等。

Avoid heat shock, vibration, direct sunlight, etc.

8. 使用注意事项 Precautions For Use

8.1 本公司产品适用于 AV 设备、OA 设备、家电、信息服务等一般电子设备中。

Our products are designed and promoted for use in general electronic devices such as audio-video equipment, office automation equipment, home appliance and information service.

8.2 当本公司的产品使用在一般电子设备以外的领域时，对于此所引发的设备失效我司将不承担任何法律责任。

In case of using the product for the purpose other than general electronics devices, we shall not be held liable for any dysfunctions in or damage to the equipment with which the product is used.

8.3 本承诺书只保证我司产品作为一个单体时的质量情况，当我司产品被安装到贵司产品上时，请贵司对使用在贵司电路上的产品情况进行了有效评价和确认。

Our specification limits the quality of the component as a single unit. Please ensure the component is thoroughly evaluated in your application circuit.

8.4 不要对产品施加过大的振动或机械冲击；

Do not apply excessive vibration or mechanical shock to products.

8.5 为防止断线，请不要使用锋利的物体接触线圈，如镊子；

Do not touch wire with sharp objects such as tweezers to prevent wire breakage.

8.6 在产品贴装时不要使用过大的压力，避免磁芯断裂。

Do not apply excessive stress to products mounted on boards to prevent core breakage.

X-ON Electronics

Largest Supplier of Electrical and Electronic Components

Click to view similar products for [Fixed Inductors](#) category:

Click to view products by [Fenghua Advanced](#) manufacturer:

Other Similar products are found below :

[MLZ1608M6R8WTD25](#) [MLZ1608N6R8LT000](#) [MLZ1608N3R3LTD25](#) [MLZ1608N3R3LT000](#) [MLZ1608N150LT000](#)

[MLZ1608M150WTD25](#) [MLZ1608M3R3WTD25](#) [MLZ1608M3R3WT000](#) [MLZ1608M150WT000](#) [MLZ1608A1R5WT000](#)

[MLZ1608N1R5LT000](#) [B82432C1333K000](#) [PCMB053T-1R0MS](#) [PCMB053T-1R5MS](#) [PCMB104T-1R5MS](#) [CR32NP-100KC](#) [CR32NP-](#)

[151KC](#) [CR32NP-180KC](#) [CR32NP-181KC](#) [CR32NP-1R5MC](#) [CR32NP-390KC](#) [CR32NP-3R9MC](#) [CR32NP-680KC](#) [CR32NP-820KC](#)

[CR32NP-8R2MC](#) [CR43NP-390KC](#) [CR43NP-560KC](#) [CR43NP-680KC](#) [CR54NP-181KC](#) [CR54NP-470LC](#) [CR54NP-820KC](#) [CR54NP-8R5MC](#)

[MGDQ4-00004-P](#) [MGDU1-00016-P](#) [MHL1ECTTP18NJ](#) [MHL1JCTTD12NJ](#) [PE-51506NL](#) [PE-53601NL](#) [PE-53630NL](#) [PE-53824SNLT](#) [PE-](#)

[62892NL](#) [PE-92100NL](#) [PG0434.801NLT](#) [PG0936.113NLT](#) [PM06-2N7](#) [PM06-39NJ](#) [HC2LP-R47-R](#) [HC2-R47-R](#) [HC3-2R2-R](#) [HC8-1R2-R](#)