



F&F Filipowski L.P.
Konstantynowska 79/81, 95-200 Pabianice, POLAND
phone/fax (+48 42) 215 23 83 / (+48 42) 227 09 71
www.fif.com.pl; e-mail: biuro@fif.com.pl

STR-3 Pico

Miniature roller blind controller for 230 V AC motors



5 19 08 31 21 59 78 34 11

Do not dispose of this device in the trash along with other waste! According to the Law on Waste, electro coming from households free of charge and can give any amount up to that end point of collection, as well as to store the occasion of the purchase of new equipment (in accordance with the principle of old-for-new, regardless of brand). Electro thrown in the trash or abandoned in nature, pose a threat to the environment and human health.



Purpose

The STR-3 Pico controller is designed to control roller blinds (**UP/DOWN**) or other objects (e.g. gates) that are driven with single-phase alternating current electric motor with momentary switch (eg. bell).

Functioning

The controller can operate as a stand-alone device (for opening/closing of a single roller blind), but it is also possible to combine controllers into groups to central control multiple roller blinds. The controller power supply is indicated by a green LED. Roller blind motor starts after momentary passing of the N signal to one of the control inputs. The motor activates for the user-programmed time that allows to fully lift or lower the roller blind. Roller blind can be stopped on the user-selected level (incomplete opening or closing of the roller blind).

Control

Controller control inputs are divided into two groups: local control and central control.

LOCAL CONTROL

Depending on how you connect the controller, it can operate in one or two local keys mode.

One local key

Local control input **DOWN** is connected permanently to the N line. Local control input **UP** is connected to a key that alternately switches the roller blind to move up or down. Short press (<0.5 s) switches on the blind for a programmed time. Pressing the key when the roller blind is already in motion causes the roller blind to stop. Long press (>0.5 s) switches on the roller blind for as long as the key is pressed.

Each time you press the key the roller blind will move in the direction opposite to the previous one.

Two local keys

Each direction of movement has its own local key. Short press (<0.5 s) switches on the roller blind to move in a given direction for the programmed period of time. Pressing the key when the roller blind is already in motion causes the roller blind to stop. Long press (>0.5 s) switches on the roller blind to move in a given direction for as long as the key is pressed (this allows for example to adjust the tilt of slats).



Memory of direction applies both to local and central control. For example, if the controller carries out a **CENTRAL UP** command, then the next press of a local key will move the roller blind down.



Memory of direction is not retained after a power failure.

CENTRAL CONTROL

The controller always works with two central control inputs. Central control allows the roller blinds to move only in the desired direction. Roller blind will stop only after a preset time or by pressing any of the local control keys.

If during the execution of one center control command another one is issued with the instruction to move in the opposite direction, the roller blind will stop at first and after 1.5 s will then start to move in the opposite direction. Time of roller blind activation can be randomly delayed in the control center (up to 1 s) to minimize the current surge in the grid in case of simultaneous activation of multiple controllers.



CENTRAL DOWN key can also close and lock the roller blind in the closed position. If the **CENTRAL DOWN** key is pressed and left in the **ON** position, the controller will close the roller blind and will not allow for its opening until the **CENTRAL DOWN** key is released (other inputs will then be locked). This function allows you to lock the roller blinds e.g. when the alarm is armed or when the rainfall (if the additional STR-R rain sensor is used) or too strong wind (if the additional STR-W wind sensor is used) is detected.

Mounting

1. Disconnect the power supply.
 2. Mount the controller on the rail in the distribution box.
 3. Connect the controller accordingly to the selected scheme of operation.
-



The controllers can be powered from any phase of the mains (also in the case of a multiple controllers operating under common central control). It is important to retain a common N line and to control inputs by the level of the neutral N line.



Both power cables and control cables must be properly shielded adequately to the voltage.

4. Switch on the power supply.
5. Program the time of lifting/lowering the roller blind.

Scheduling time of activation

Time of activation can be programmed upon the assumed time of roller blind operation or by activating the roller blind for the test run:

Scheduling for the specified time

1. Press and hold (for approx. 4 s) the **PROG** key until the green U LED will begin to flash slowly. The controller is now ready for programming.
2. Short press **PROG** key – the controller starts to measure out the activation time, which is indicated by rapid flashing of U LEDs.
3. After the time has been measured out, press the **PROG** key again. The controller will save the elapsed time in non-volatile memory and then exit the programming mode, which is indicated by the constant U LED light.

Test run

1. Place the blind in the outmost top or bottom position.
2. Press and hold (for approx. 4 s) the **PROG** key until the green U LED will begin to flash slowly. The controller is now ready for programming.
3. Short press the local control **UP** or **DOWN** key (in the opposite direction to the current position of the roller blind). The controller starts the motor and begins to measure out the time.
4. After the time has been measured out, press any of the local control keys. The roller blind motor will stop and the controller will save the elapsed time in "non-volatile" memory and then exit the programming mode.



If during the first 30 seconds of the learning mode (slow flashing of U LED) the time measuring will not start (the **PROG** key is pressed or the roller blind is activated from the local control input), the controller will exit the learning mode.



The controller is designed to measure time span shorter than 5 min. Attempting to set the controller for longer span will result in exit from the learning mode.



The controller learning mode can be started only when the roller blind motor is turned off.



Operation with factory settings (activation time set to 30 seconds) is indicated in standby mode by short (0.1 s) blinking of U LED repeated every 4 s.

Wiring diagram

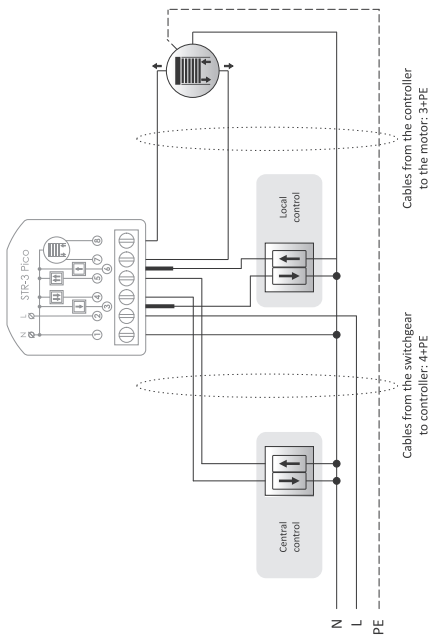

Description of terminals

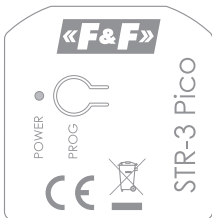
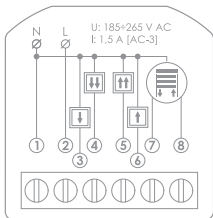

- 1 controller power supply N
 - 2 controller power supply L
 - 3 local control – **DOWN** ↓ direction
 - 4 central control – **DOWN** ↓ ↓ direction
 - 5 central control – **UP** ↑ ↑ direction
 - 6 local control – **UP** ↑ direction
 - 7 motor power supply – **DOWN** ↓ direction
 - 8 motor power supply – **UP** ↑ direction
- POWER LED indication of power and programming
- PROG time programming button

Technical data

power supply	185÷265 V AC
maximum load current (AC-1/AC-3)	3 A/1,5 A
power consumption	
standby	0.15 W
on	0.4 W
control	triggered N level
switch-on time (adjustable)	1 s÷5 min.
power and programming indication	green LED
working temperature	-25÷50°C
terminal	2.5 mm ² screw terminals
tightening torque	0.4 Nm
local control terminal	2×DY 1 mm ² /l= 10 mm
dimensions	35×36×19 mm
mounting	flush-mounted box ø60
protection level	IP20

Application examples

The application examples listed below can be downloaded from the website www.fif.com.pl from the product subpage:

1. Wiring example: one local button mode.
2. Wiring example: two local button mode.
3. Group control example.
4. Example of extensive control with division into additional groups of roller shutters.

Warranty

F&F products are covered by a 24-month warranty from the date of purchase. The warranty is only valid with proof of purchase. Contact your dealer or contact us directly.

CE declaration

F&F Filipowski L.P. declares that the device is in conformity with the essential requirements of The Low Voltage Directive (LVD) 2014/35/EU and the Electromagnetic Compatibility (EMC) Directive 2014/30/UE.

The CE Declaration of Conformity, along with the references to the standards in relation to which conformity is declared, can be found at www.fif.com.pl from the product subpage.

«F&F»[®]

X-ON Electronics

Largest Supplier of Electrical and Electronic Components

Click to view similar products for [Specialist Controllers](#) category:

Click to view products by [F&F](#) manufacturer:

Other Similar products are found below :

[CV500SLK21](#) [81550401](#) [H2CRSAC110B](#) [R88ARR080100S](#) [E53E01](#) [E53E8C](#) [E5GNQ03PFLKACDC24](#) [B300LKL21](#) [NSCXDC1V3](#)
[NT20SST122BV1](#) [C40PEDRA](#) [K31S5](#) [K31S6](#) [K3TX-AD31A](#) [L595020](#) [26546803](#) [26546805](#) [H7HP-C8D](#) [PWRA440A](#) [CPM1AETL03CH](#)
[3G2A5BI081](#) [3G2A5IA122](#) [3G2A5OD211](#) [3G2A5RM001EV1](#) [3G2A5RT002EV1](#) [3G2A6-ID217](#) [3G2A6LK202EV1](#) [3G2A9AL004E](#)
[C200HETL01E](#) [C200PCPD024](#) [3G2A5AD001](#) [3G2A5BI051](#) [3G2A5IA121](#) [3G2A5ID112](#) [3G2A5ID213](#) [3G2A5ID219](#) [3G2A5MR431](#)
[3G2A5OC221](#) [3G2A5PS222E](#) [3G2A6IM213](#) [3G2A6-OD412](#) [3G2A9AL001](#) [3G2C7LK202EV1](#) [3G5A2OC221E](#) [LDP2TA2B115](#)
[3G3DV130B4294](#) [E53E04](#) [E53Q4Q4](#) [E54E8CT](#) [C200HWC0M06EV1](#)