

Product Specification

Fast Ethernet RoHS Compliant Long-Wavelength SFP Transceiver

FTLF1217P2xTL

PRODUCT FEATURES

- Up to 200 Mb/s bi-directional data links
- Hot-pluggable SFP footprint
- Built-in digital diagnostic functions
- 1310nm LED-based transmitter
- Duplex LC connector
- RoHS Compliant and Lead-Free
- Up to 2km on 62.5/125µm MMF
- Metal enclosure, for lower EMI
- Single 3.3V power supply
- Low power dissipation
- Industrial operating temperature range: -40°C to 85°C



APPLICATIONS

- 125 Mb/s 100Base-FX Ethernet / FDDI
- 200 Mb/s ESCON
- 155 Mb/s Multimode SONET OC-3 SR-0
- 51 Mb/s Multimode SONET OC-1 SR-0

Finisar's FTLF1217P2xTL Small Form Factor Pluggable (SFP) transceivers are compatible with the Small Form Factor Pluggable Multi-Sourcing Agreement (MSA)¹. They are simultaneously compatible with 100Base-FX, FDDI, ESCON, and Multimode SONET OC-3 SR-0 and OC-1 SR-0 standards as specified in IEEE Std 802.3², ISO/IEC 9314-3³, Enterprise Systems Architecture/390⁴, and ANSI T1.416.01-1999⁵, respectively. They are RoHS compliant and lead-free per Directive 2002/95/EC⁴ and Finisar Application Note AN-2038. Digital diagnostics functions are available via the 2-wire serial bus specified in the SFP MSA.

PRODUCT SELECTION

FTLF1217P2xTL

x	W	Wide Extraction Bail
	B	Narrow Extraction Bail

I. Pin Descriptions

Pin	Symbol	Name/Description	Ref.
1	V _{EET}	Transmitter Ground (Common with Receiver Ground)	1
2	T _{FAULT}	Transmitter Fault.	2
3	T _{DIS}	Transmitter Disable. LED output disabled on high or open.	3
4	MOD_DEF(2)	Module Definition 2. Data line for Serial ID.	4
5	MOD_DEF(1)	Module Definition 1. Clock line for Serial ID.	4
6	MOD_DEF(0)	Module Definition 0. Grounded within the module.	4
7	Rate Select	No connection required	
8	LOS	Loss of Signal indication. Logic 0 indicates normal operation.	5
9	V _{EER}	Receiver Ground (Common with Transmitter Ground)	1
10	V _{EER}	Receiver Ground (Common with Transmitter Ground)	1
11	V _{EER}	Receiver Ground (Common with Transmitter Ground)	1
12	RD-	Receiver Inverted DATA out. AC Coupled	
13	RD+	Receiver Non-inverted DATA out. AC Coupled	
14	V _{EER}	Receiver Ground (Common with Transmitter Ground)	1
15	V _{CCR}	Receiver Power Supply	
16	V _{CCT}	Transmitter Power Supply	
17	V _{EET}	Transmitter Ground (Common with Receiver Ground)	1
18	TD+	Transmitter Non-Inverted DATA in. AC Coupled.	
19	TD-	Transmitter Inverted DATA in. AC Coupled.	
20	V _{EET}	Transmitter Ground (Common with Receiver Ground)	1

Notes:

1. Circuit ground is internally isolated from chassis ground.
2. T_{FAULT} is an open collector/drain output, which should be pulled up with a 4.7k – 10k Ohms resistor on the host board. Pull up voltage should be between 2.0V to V_{cc} + 0.3V. A high output indicates an LED fault, i.e. LED open or short. Low indicates normal operation. In the low state, the output is pulled to <0.8V.
3. LED output disabled on T_{DIS} >2.0V or open, enabled on T_{DIS} <0.8V.
4. Should be pulled up with 4.7k – 10kohms on host board to a voltage between 2.0V and 3.6V. MOD_DEF(0) pulls line low to indicate module is plugged in.
5. LOS is open collector output. Should be pulled up with 4.7k – 10kohms on host board to a voltage between 2.0V and 3.6V. Logic 0 indicates normal operation; logic 1 indicates loss of signal.

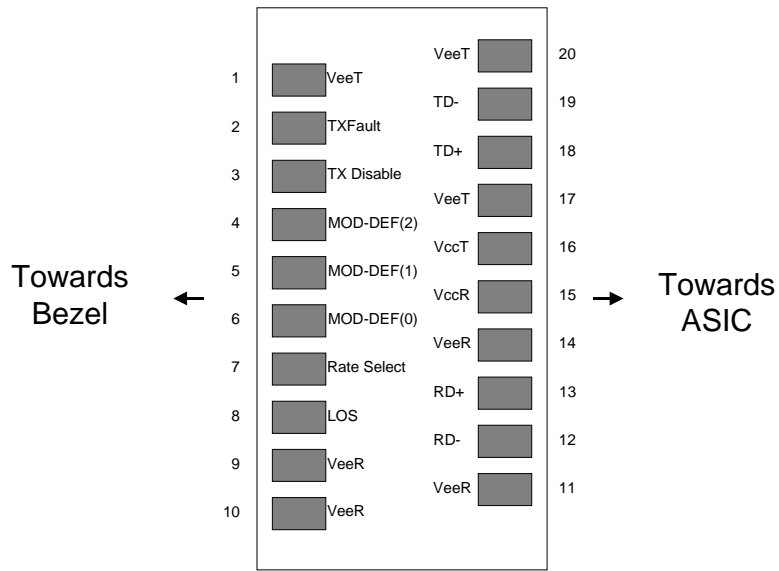

Diagram of Host Board Connector Block Pin Numbers and Names

II. Absolute Maximum Ratings

Parameter	Symbol	Min	Typ	Max	Unit	Ref.
Maximum Supply Voltage	V _{CC}	-0.5		4.0	V	
Storage Temperature	T _S	-40		85	°C	
Case Operating Temperature	T _A	-40		85	°C	
Relative Humidity	RH	0		85	%	1

III. Electrical Characteristics (T_A = -40 to 85 °C, V_{CC} = 3.0 to 3.6 Volts)

Parameter	Symbol	Min	Typ	Max	Unit	Ref.
Supply Voltage	V _{CC}	3.0		3.6	V	
Supply Current	I _{CC}			300	mA	
Transmitter						
Input differential impedance	R _{in}		100		Ω	2
Single ended data input swing	V _{in,pp}	250		1200	mV	3
Transmit Disable Voltage	V _D	2		V _{CC}	V	4
Transmit Enable Voltage	V _{EN}	V _{EE}		V _{EE} + 0.8	V	
Receiver						
Single ended data output swing	V _{out,pp}	250	450	900	mV	5
Data output rise/fall time ≤ 155 Mb/s	t _r /t _f	0.6		5.0	ns	6
LOS Fault	V _{LOS fault}	2		V _{CCHOST}	V	7
LOS Normal	V _{LOS norm}	V _{EE}		V _{EE} +0.5	V	7
Power Supply Rejection	PSR	100			mVpp	8
Systematic Jitter Contribution	RX Δ SJ			2.0	ns	9
Contributed Duty Cycle Distortion	RX Δ DCD			1.0	ns	10
Data Dependent Jitter Contribution	RX Δ DDJ			1.2	ns	10
Random Jitter Contribution @ OC-3 and OC-1	RX Δ RJ			0.6	ns	9
Random Jitter Contribution @ FE	RX Δ RJ			0.76	ns	10

Notes:

1. Non condensing.
2. Connected directly to TX data input pins. AC coupling from pins into driver IC.
3. We recommend <600mV for best EMI performance.
4. Or open circuit.
5. Into 100 ohms differential termination.
6. 10 – 90 %
7. LOS is an open collector output. Should be pulled up with 4.7k – 10kohms on the host board. Normal operation is logic 0; loss of signal is logic 1. Maximum pull-up voltage is 5.5V.
8. Receiver sensitivity is compliant with power supply sinusoidal modulation of 20 Hz to 1.5 MHz up to specified value applied through the recommended power supply filtering network.
9. Peak-to-peak measurement for OC-3 SR-0 or OC-1 SR-0 operation measured with a PRBS 2²³-1 test pattern.
10. Peak-to-peak measurement based on 4B/5B encoded Fast Ethernet pattern referenced in FDDI PMD³ Annex A.5

IV. Optical Characteristics ($T_{OP} = -40$ to 85 °C, $V_{CC} = 3.00$ to 3.60 Volts)

Parameter	Symbol	Min	Typ	Max	Unit	Ref.
Transmitter						
Output Opt. Power	P_{OUT}	-20		-15	dBm	1
Optical Wavelength	λ	1280		1380	nm	
Spectral Width (FWHM)	σ		175		nm	2
Optical Rise/Fall Time ≤ 155 Mb/s	t_r/ t_f	0.6		3.0	ns	3
Optical Rise/Fall Time = 200 Mb/s	t_r/ t_f			1.7	ns	4
Systematic Jitter Contribution	$TX \Delta SJ$			1.6	ns	5
Contributed Duty Cycle Distortion	$TX \Delta DCD$			1.0	ns	6
Data Dependent Jitter Contribution	$TX \Delta DDJ$			0.6	ns	6
Random Jitter Contribution @ OC-3 and OC-1	$TX \Delta RJ$			0.6	ns	5
Random Jitter Contribution @ FE	$TX \Delta RJ$			0.76	ns	6
Extinction Ratio	ER	10			dB	
Receiver						
Receiver Sensitivity = 51.8 Mb/s	R_{XSENS}			-30	dBm	7
Receiver Sensitivity = 155 Mb/s	R_{XSENS}			-30	dBm	7
Receiver Sensitivity = 125 Mb/s	R_{XSENS}			-31	dBm	7
Receiver Sensitivity = 200 Mb/s	R_{XSENS}			-29	dBm	8
Maximum Average Receiver Power	R_{XMAX}			-14	dBm	
Optical Center Wavelength	λ_C	1270		1600	nm	
LOS De-Assert	LOS_D			-33	dBm	
LOS Assert	LOS_A	-45			dBm	
LOS Hysteresis		1.5			dB	

Notes:

1. Measured average power coupled into 62.5/125um fibre with NA = 0.275. Class 1 eye safety per FDA/CDRH, IEC, and EN60825-1 safety standards.
2. Also specified to fall within the extrapolated curves in FDDI PMD³ Figure 9, which allow trade-off between wavelength, spectral width and transmitter rise/fall times.
3. Unfiltered, 10-90%.
4. Unfiltered, 20-80%.
5. Peak-to-peak measurement for OC-3 SR-0 or OC-1 SR-0 operation measured with a PRBS 2²³-1 test pattern.
6. Peak-to-peak measurement based on 4B/5B encoded Fast Ethernet pattern referenced in FDDI PMD³ Annex A.5
7. Specifications are for 50 micro-meter or 62.5 micro-meter fiber.
8. Specifications are for 50 micro-meter or 62.5 micro-meter fiber, based on any valid 8B/10B code pattern and measured at, or extrapolated to, 10⁻¹⁵ BER.

V. General Specifications

Parameter	Symbol	Min	Typ	Max	Units	Ref.
Data Rate	BR		51.8, 155, 125, 200		Mb/sec	1
Bit Error Rate	BER			10^{-10}		
Max. Supported Link Length on 50/125 μ m or 62.5 μ m MMF @ OC-1	L _{MAX1}		3		km	2
Max. Supported Link Length on 50/125 μ m or 62.5 μ m MMF @ OC-3	L _{MAX2}		2		km	3
Max. Supported Link Length on 50/125 μ m or 62.5 μ m MMF @ FE	L _{MAX3}		2		km	4
Max. Supported Link Length on 50/125 μ m or 62.5 μ m MMF @ ESCON	L _{MAX4}		2		km	5

Notes:

1. Multimode SONET OC-1 SR-0 and OC-3 SR-0, 100Base-FX and FDDI compliant as specified in ANSI T1.416.01-1999⁵, IEEE Std 802.3², and ISO/IEC 9314-3³ respectively. ESCON compatible as specified in Enterprise Systems Architecture/390⁴.
2. At 51.8 Mb/s data rate per ANSI T1.416.01-1999⁵.
3. At 155 Mb/s data rate per ANSI T1.416.01-1999⁵.
4. At 125 Mb/s data rate per ISO/IEC 9314-3³.
5. At 200 Mb/s data rate per Enterprise Systems Architecture/390⁴.

VI. Environmental Specifications

Finisar 1310nm SFP transceivers have an industrial operating temperature range from -40°C to $+85^{\circ}\text{C}$ case temperature.

Parameter	Symbol	Min	Typ	Max	Units	Ref.
Case Operating Temperature	T _{op}	-40		85	$^{\circ}\text{C}$	
Storage Temperature	T _{sto}	-40		85	$^{\circ}\text{C}$	

VII. Regulatory Compliance

Finisar transceivers are Class 1 eye safety products and comply with US FDA regulations. These products are certified by TÜV and CSA to meet the Class 1 eye safety requirements of EN (IEC) 60825 and the electrical safety requirements of EN (IEC) 60950. Copies of certificates are available at Finisar Corporation upon request. Copies of the referenced certificates are available at Finisar Corporation upon request.

VIII. Digital Diagnostic Functions

Finisar FTLF1217P2xTL SFP transceivers support the 2-wire serial communication protocol as defined in the SFP MSA¹. It is very closely related to the E²PROM defined in the GBIC standard, with the same electrical specifications.

The standard SFP serial ID provides access to identification information that describes the transceiver's capabilities, standard interfaces, manufacturer, and other information.

Additionally, Finisar SFP transceivers provide a unique enhanced digital diagnostic monitoring interface, which allows real-time access to device operating parameters such as transceiver temperature, bias current, transmitted optical power, received optical power and transceiver supply voltage. It also defines a sophisticated system of alarm and warning flags, which alerts end-users when particular operating parameters are outside of a factory set normal range.

The SFP MSA defines a 256-byte memory map in E²PROM that is accessible over a 2-wire serial interface at the 8 bit address 1010000X (A0h). The digital diagnostic monitoring interface makes use of the 8 bit address 1010001X (A2h), so the originally defined serial ID memory map remains unchanged. The interface is identical to, and is thus fully backward compatible with both the GBIC Specification and the SFP Multi Source Agreement. The complete interface is described in Finisar Application Note AN-2030: "Digital Diagnostics Monitoring Interface for SFP Optical Transceivers".

The operating and diagnostics information is monitored and reported by a Digital Diagnostics Transceiver Controller (DDTC) inside the transceiver, which is accessed through a 2-wire serial interface. When the serial protocol is activated, the serial clock signal (SCL, Mod Def 1) is generated by the host. The positive edge clocks data into the SFP transceiver into those segments of the E²PROM that are not write-protected. The negative edge clocks data from the SFP transceiver. The serial data signal (SDA, Mod Def 2) is bi-directional for serial data transfer. The host uses SDA in conjunction with SCL to mark the start and end of serial protocol activation. The memories are organized as a series of 8-bit data words that can be addressed individually or sequentially.

For more information, please see the SFP MSA documentation^{1,7} or Finisar Application Note AN-2030.

Please note that evaluation board FDB-1018 is available with Finisar ModDEMO software that allows simple to use communication over the 2-wire serial interface.

IX. Digital Diagnostic Specifications

FTLF1217P2xTL transceivers have internally calibrated digital diagnostics.

Parameter	Symbol	Min	Typ	Max	Units	Ref.
Accuracy						
Internally measured transceiver temperature	DD _{Temperature}			± 3	°C	
Internally measured transceiver supply voltage	DD _{Voltage}			± 100	mV	
Measured TX bias current	DD _{Bias}			± 10	%	1
Measured TX output power	DD _{Tx-Power}			± 3	dB	
Measured RX received average optical power	DD _{Rx-Power}			± 3	dB	
Dynamic Range for Rated Accuracy						
Internally measured transceiver temperature	DD _{Temperature}	-40		85	°C	
Internally measured transceiver supply voltage	DD _{Voltage}	3.0		3.6	V	
Measured TX bias current	DD _{Bias}	0		70	mA	
Measured TX output power	DD _{Tx-Power}	-22		-13	dBm	
Measured RX received average optical power	DD _{Rx-Power}	-33		-12	dBm	
Max Reporting Range						
Internally measured transceiver temperature	DD _{Temperature}	-40		125	°C	
Internally measured transceiver supply voltage	DD _{Voltage}	2.8		4.0	V	
Measured TX bias current	DD _{Bias}	0		80	mA	
Measured TX output power	DD _{Tx-Power}	-24		-11	dBm	
Measured RX received average optical power	DD _{Rx-Power}	-35		-10	dBm	

Notes:

1. Accuracy of Measured Tx Bias Current is 10% of the actual Bias Current from the driver to the LED.

X. Mechanical Specifications

Finisar’s Small Form Factor Pluggable (SFP) transceivers are compatible with the dimensions defined by the SFP Multi-Sourcing Agreement (MSA).

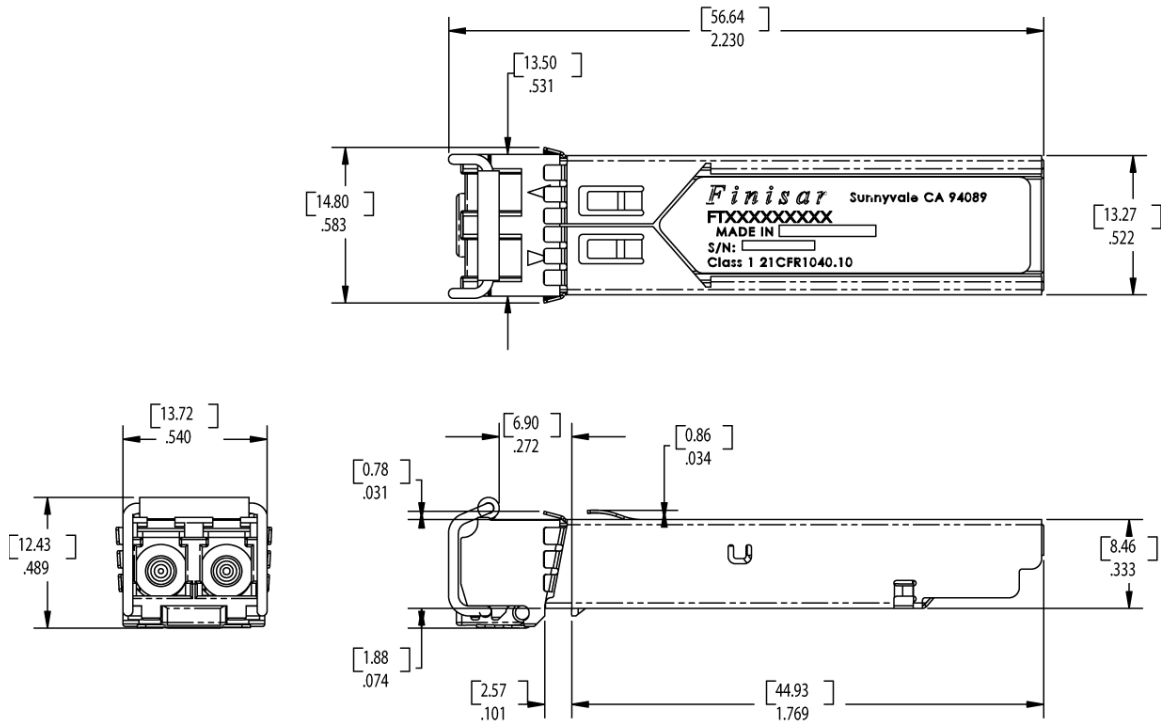

FTLF1217P2BTL

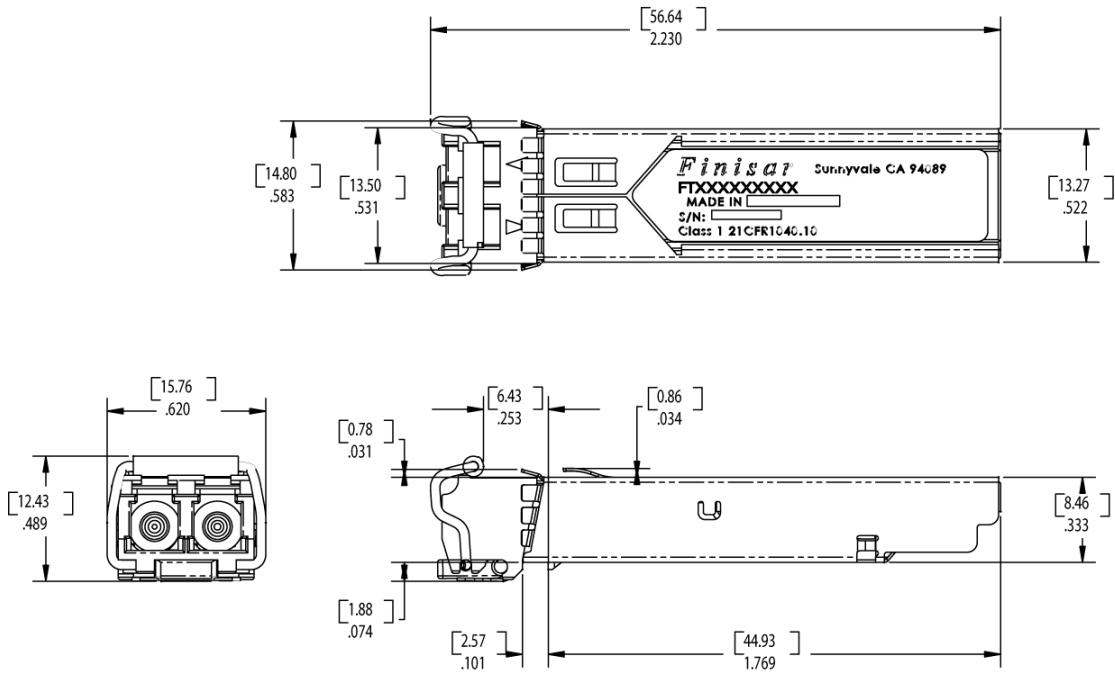

FTLF1217P2WTL

XI. PCB Layout and Bezel Recommendations

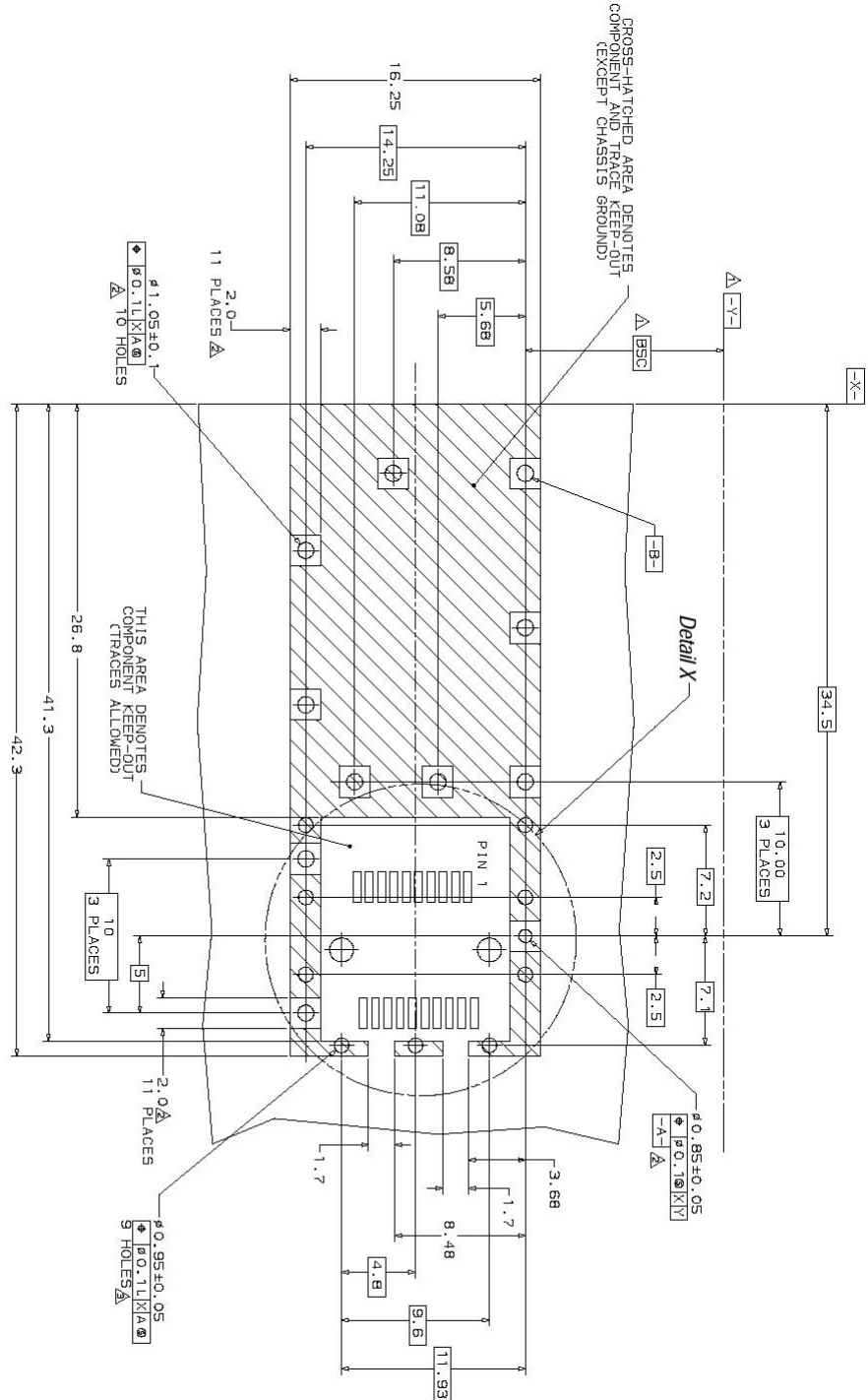

- Return and Basic Dimension Established by Customer
- Pads and Vias are Chassis Ground, 11 Places
- Through Holes are Unplated

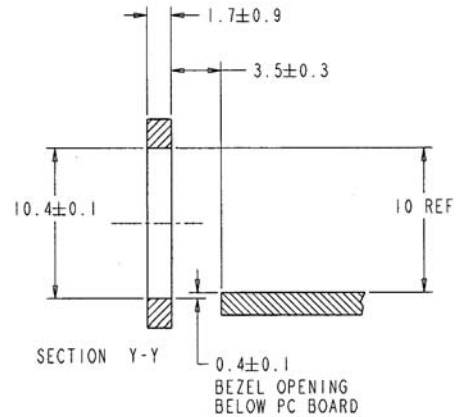
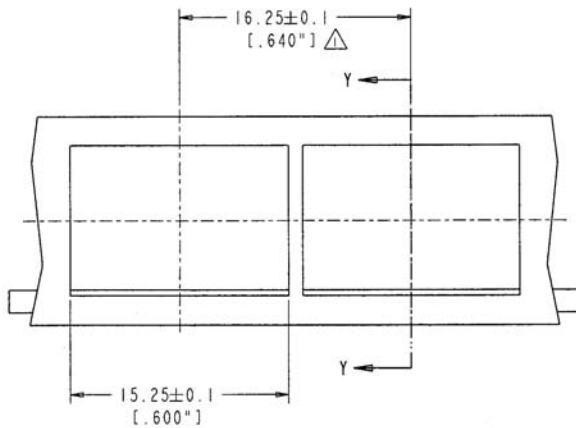
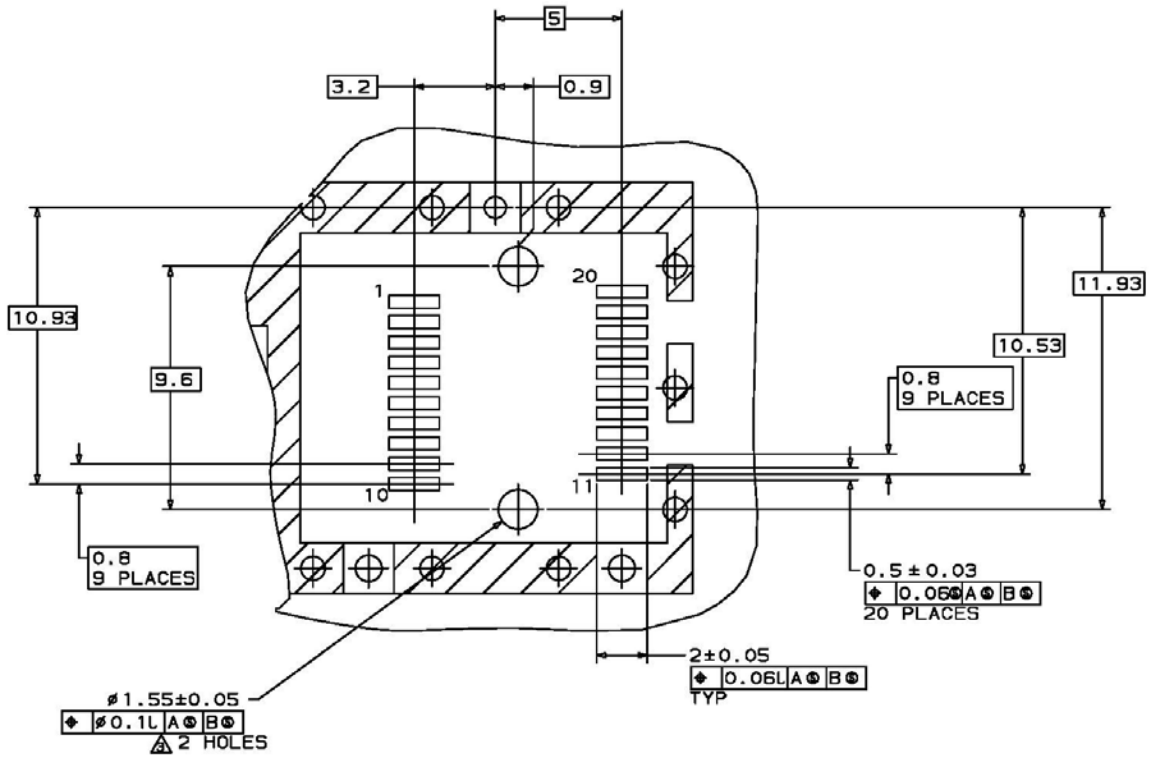

NOTES:

△ MINIMUM PITCH ILLUSTRATED, ENGLISH DIMENSIONS ARE FOR REFERENCE ONLY

2. NOT RECOMMENDED FOR PCI EXPANSION CARD APPLICATIONS

XII. References

1. Small Form-factor Pluggable (SFP) Transceiver Multi-source Agreement (MSA). September 14, 2000.
2. IEEE Std 802.3, 2002 Edition, Clause 38, PMD Type 1000BASE-LX. IEEE Standards Department, 2002.
3. ISO/IEC 9314-3. “Information Processing Systems – Fibre Distributed Data Interface (FDDI), Part 3, Physical Layer Medium Dependent (PMD).” 1990.
4. Enterprise Systems Architecture/390, ESCON I/O Interface, Physical Layer. IBM Corp., Third Edition, 1996.
5. ANSI T1.416.01-1999. “Network to Customer Installation Interfaces – Synchronous Optical NETWORK (SONET) Physical Media Dependent Specification: Multi-Mode Fiber.” ANSI, 1999.
6. Directive 2002/95/EC of the European Council Parliament and of the Council, “on the restriction of the use of certain hazardous substances in electrical and electronic equipment.” January 27, 2003.
7. “Digital Diagnostics Monitoring Interface for Optical Transceivers”. SFF Document Number SFF-8472, Revision 9.3.

XIII. For More Information

Finisar Corporation
1389 Moffett Park Drive
Sunnyvale, CA 94089-1133
Tel. 1-408-548-1000
Fax 1-408-541-6138
sales@finisar.com
www.finisar.com

X-ON Electronics

Largest Supplier of Electrical and Electronic Components

Click to view similar products for [Fibre Optic Transmitters, Receivers, Transceivers](#) category:

Click to view products by [Finisar](#) manufacturer:

Other Similar products are found below :

[STV.2413-574-00262](#) [TRPRG1VA1C000E2G](#) [TOTX1350\(V,F\)](#) [FTLX3813M349](#) [SCN-1428SC](#) [LTK-ST11MB](#) [HFD8003-002/XBA](#)
[HFD3020-500-ABA](#) [FTLF1429P3BCVA](#) [S6846](#) [SCN-2638SC](#) [FTL410QE4N](#) [FTLC9555FEPM](#) [TQS-QG4H9-J83](#) [SCN-1570SC](#) [SCN-](#)
[1601SC](#) [SCN-1338SC](#) [SFPPT-SR3-01](#) [HFD8003-500-XBA](#) [SCN-1383SC](#) [2333569-1](#) [LNK-ST11HB-R6](#) [FTL4C1QL3L](#) [FTL4C1QE3L](#)
[FTL4C1QL3C](#) [SPTSHP3PMCDF](#) [SPTSBP4LLCDF](#) [SPTMBP1PMCDF](#) [SPTSHP2PMCDF](#) [SF-NLNAMB0001](#) [SPTSHP2SLCDF](#)
[SPTSQP4LLCDF](#) [1019682](#) [1019683](#) [1019705](#) [HFBR-1415Z](#) [AFBR-5803ATQZ](#) [AFBR-5803ATZ](#) [PLR135/T9](#) [TGW-Q14BB-FCQ](#) [AFBR-](#)
[5803AZ](#) [TQS-Q1LH8-XCA03](#) [TQS-Q1LH8-XCA05](#) [TQS-Q1LH8-XCA10](#) [TQS-Q1LH9-2CA](#) [HFBR-1414Z](#) [HFBR-1527Z](#) [HFBR-1528Z](#)
[HFBR-2406Z](#) [HFBR-2505AZ](#)