

PIN Connection TO-220F

General Description

FIR4N60FG is an N-channel enhancement mode power MOS field effect transistor which is produced using Silan proprietary F-Cell™ structure VDMOS technology. The improved planar stripe cell and the improved guard ring terminal have been especially tailored to minimize on-state resistance, provide superior switching performance, and withstand high energy pulse in the avalanche and commutation mode.

These devices are widely used in AC-DC power suppliers, DC DC converters and H-bridge PWM motor drivers.

Features

- 4A,600V, $R_{DS(on)} (typ) = 2.0\Omega @ V_{GS}=10V$
- Low gate charge
- Low Crss
- Fast switching
- Improved dv/dt capability

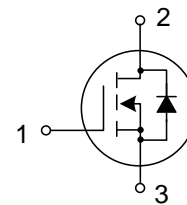
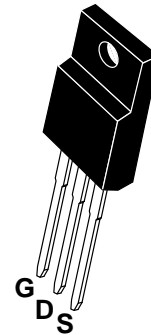

Marking Diagram



- Y = Year
- A = Assembly Location
- WW = Work Week
- FIR4N60F = Specific Device Code

Absolute Maximum Ratings (Ta = 25°C unless otherwise noted; reference only)

| Characteristics | Symbol | Ratings | Unit |
|---|-----------|-------------------|------|
| Drain-Source Voltage | V_{DS} | 600 | V |
| Gate-Source Voltage | V_{GS} | ±30 | V |
| Drain Current | I_D | $T_C=25^\circ C$ | 4.0 |
| | | $T_C=100^\circ C$ | 2.5 |
| Drain Current Pulsed | I_{DM} | 16 | A |
| Power Dissipation($T_C=25^\circ C$) -Derate above 25°C | P_D | 33 | W |
| | | 0.26 | W/°C |
| Single Pulsed Avalanche Energy(Note 1) | E_{AS} | 217 | mJ |
| Operation Junction Temperature Range | T_J | -55~+150 | °C |
| Storage Temperature Range | T_{stg} | -55~+150 | °C |

Thermal Characteristics

| Characteristics | Symbol | Ratings | Unit |
|---|-----------------|---------|------|
| Thermal Resistance, Junction-to-Case | $R_{\theta JC}$ | 1.61 | °C/W |
| Thermal Resistance, Junction-to-Ambient | $R_{\theta JA}$ | 110 | °C/W |

Electrical Characteristics (Ta = 25°C unless otherwise noted; reference only)

| Characteristics | Symbol | Test conditions | Min. | Typ. | Max. | Unit |
|--|--------------|---|------|--------|-----------|----------|
| Drain -Source Breakdown Voltage | B_{VDSS} | 25 °C, $V_{GS}=0V, I_D=250\mu A$ | 600 | -- | -- | V |
| | | 125 °C, $V_{GS}=0V, I_D=250\mu A$ | 600 | -- | -- | V |
| Drain-Source Leakage Current | I_{DSS} | 25 °C, $V_{DS}=800V, V_{GS}=0V$ | -- | -- | 10 | uA |
| | | 125 °C, $V_{DS}=800V, V_{GS}=0V$ | -- | -- | 50 | uA |
| | | 150 °C, $V_{DS}=800V, V_{GS}=0V$ | -- | -- | 100 | uA |
| Gate-Source Leakage Current | I_{GSS} | $V_{GS}=\pm 30V, V_{DS}=0V$ | -- | -- | ± 100 | nA |
| Gate Threshold Voltage | $V_{GS(th)}$ | $V_{GS}=V_{DS}, I_D=250\mu A$ | 2.0 | -- | 4.0 | V |
| Static Drain- Source On State Resistance | $R_{DS(on)}$ | $V_{GS}=10V, I_D=2A$ | -- | 2.0 | 2.4 | Ω |
| Input Capacitance | C_{iss} | $V_{DS}=25V, V_{GS}=0V,$ $f=1.0MHZ$ | -- | 509.00 | -- | pF |
| Output Capacitance | C_{oss} | | -- | 57.57 | -- | |
| Reverse Transfer Capacitance | C_{rss} | | -- | 2.59 | -- | |
| Turn-on Delay Time | $t_{d(on)}$ | $V_{DD}=300V, I_D=4A,$ $R_G=25\Omega$ (Note2,3) | -- | 14.20 | -- | ns |
| Turn-on Rise Time | t_r | | -- | 27.73 | -- | |
| Turn-off Delay Time | $t_{d(off)}$ | | -- | 34.67 | -- | |
| Turn-off Fall Time | t_f | | -- | 28.53 | -- | |
| Total Gate Charge | Q_g | $V_{DS}=480V, I_D=4A,$ $V_{GS}=10V$ (Note 2,3) | -- | 11.88 | -- | nC |
| Gate-Source Charge | Q_{gs} | | -- | 3.33 | -- | |
| Gate-Drain Charge | Q_{gd} | | -- | 4.90 | -- | |

Source-Drain Diode Ratings And Characteristics

| Characteristics | Symbol | Test conditions | Min. | Typ. | Max. | Unit |
|---------------------------|----------|---|------|------|------|---------|
| Continuous Source Current | I_S | Integral Reverse P-N Junction Diode in the MOSFET | -- | -- | 4.0 | A |
| Pulsed Source Current | I_{SM} | | -- | -- | 16 | |
| Diode Forward Voltage | V_{SD} | $I_S=4.0A, V_{GS}=0V$ | -- | -- | 1.4 | V |
| Reverse Recovery Time | T_{rr} | $I_S=4.0A, V_{GS}=0V,$ $di_F/dt=100A/\mu s$ (Note 2) | -- | 408 | -- | ns |
| Reverse Recovery Charge | Q_{rr} | | -- | 1.98 | -- | μC |

Notes:

1. $L=30mH, I_{AS}=3.45A, V_{DD}=100V, R_G=25\Omega,$ starting $T_J=25^\circ C$;
2. Pulse Test: Pulse width $\leq 300\mu s,$ Duty cycle $\leq 2\%$;
3. Essentially independent of operating temperature.

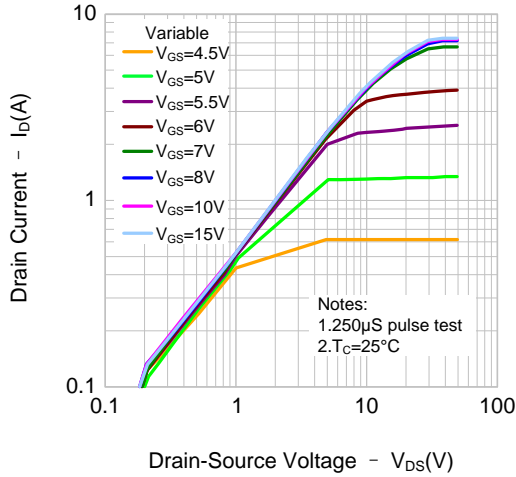
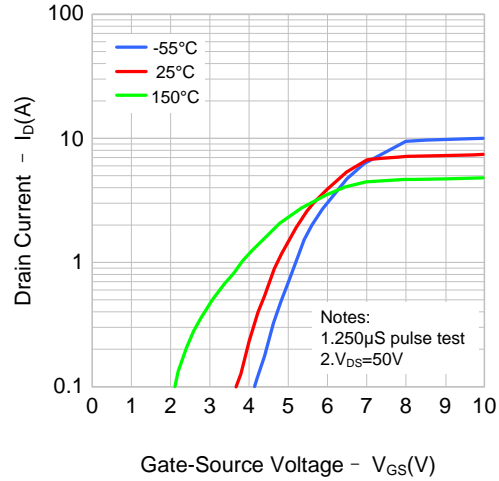
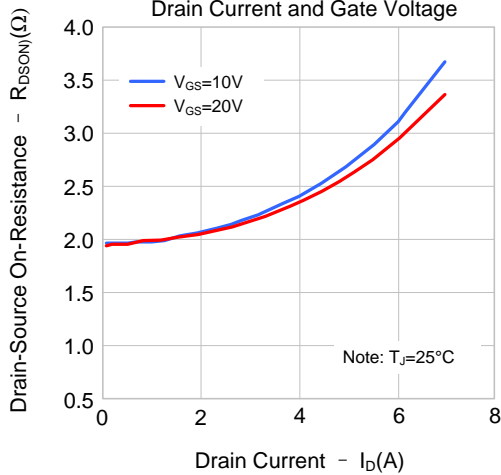
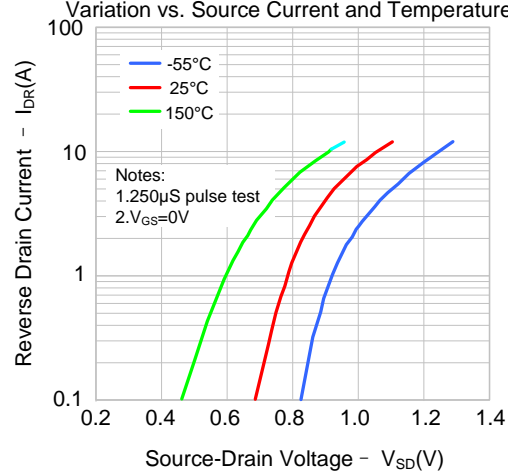
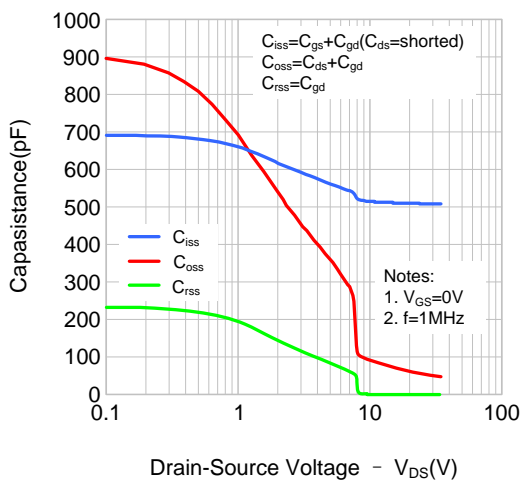
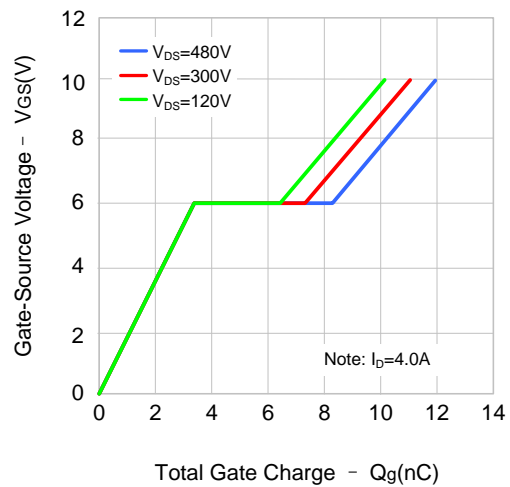
Typical Characteristics
Figure 1. On-Region Characteristics

Figure 2. Transfer Characteristics

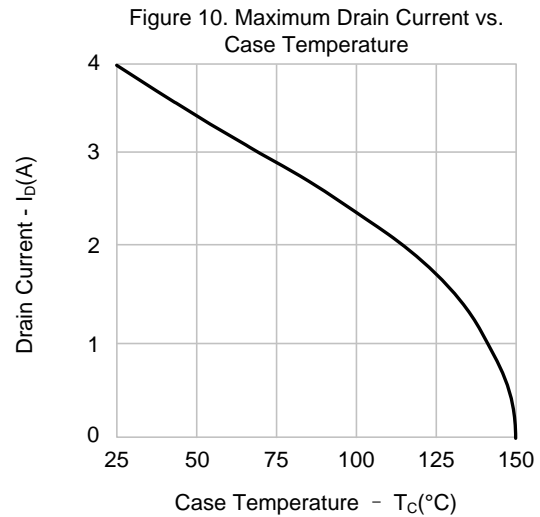
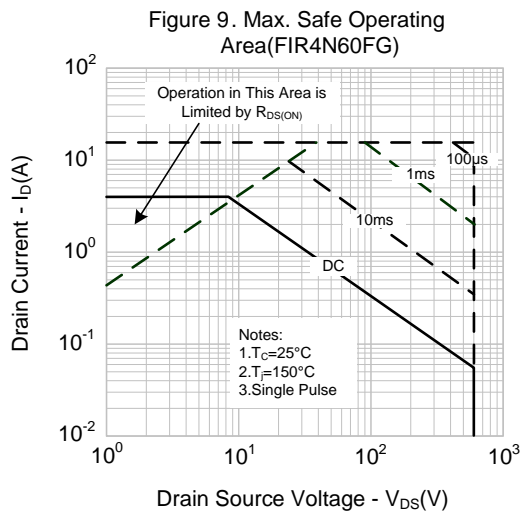
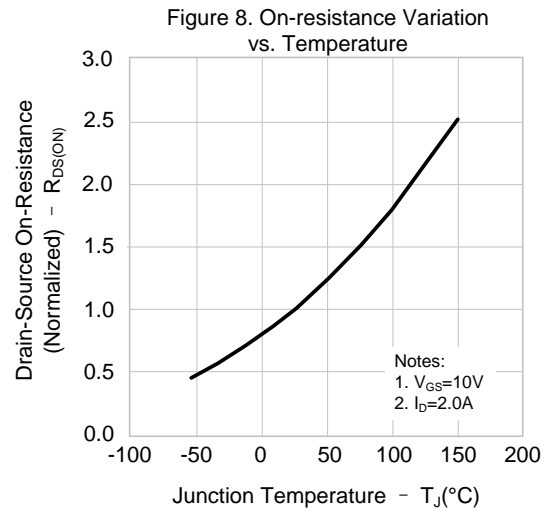
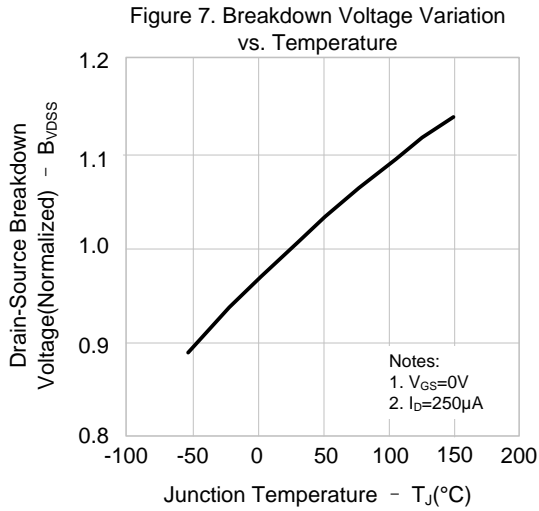
Figure 3. On-Resistance Variation vs. Drain Current and Gate Voltage

Figure 4. Body Diode Forward Voltage Variation vs. Source Current and Temperature

Figure 5. Capacitance Characteristics

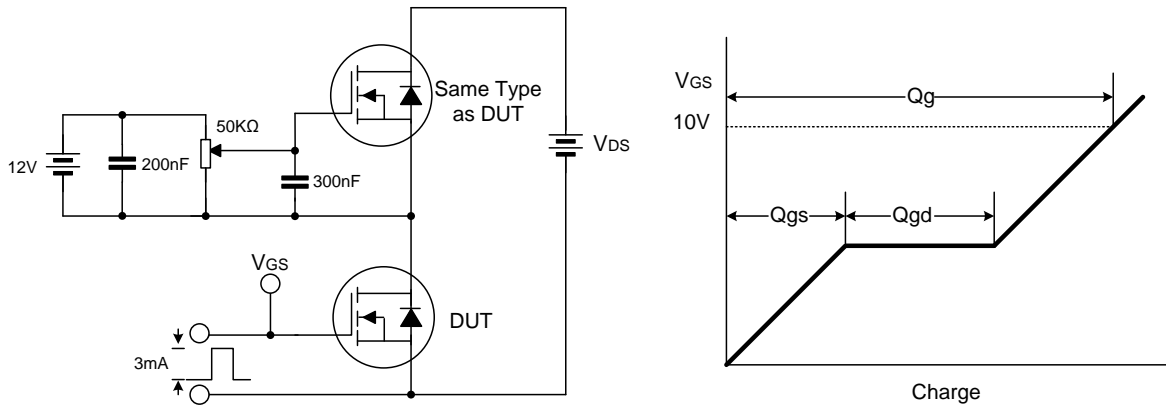
Figure 6. Gate Charge Characteristics

Typical Characteristics(Continued)



Typical Test Circuit

Gate Charge Test Circuit & Waveform



Resistive Switching Test Circuit & Waveform

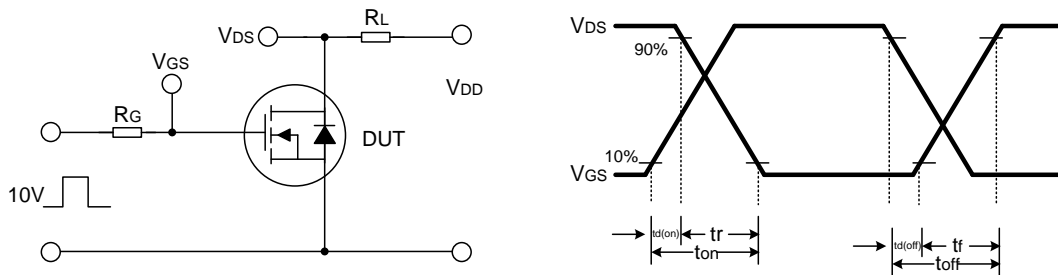

Unclamped Inductive Switching Test Circuit & Waveform

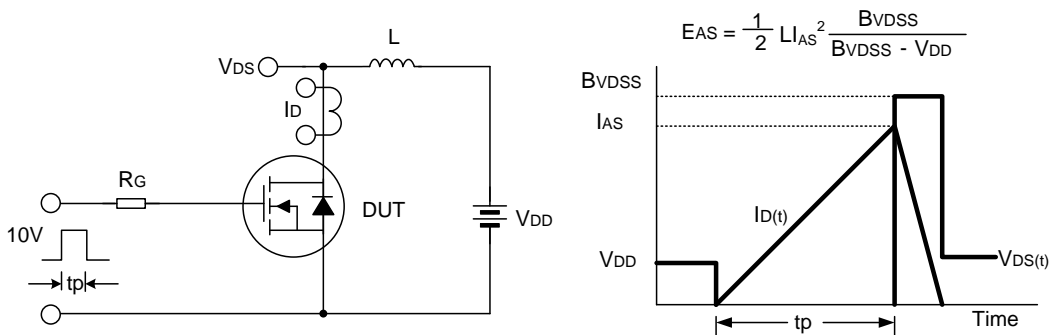

Package Dimensions

TO-220F

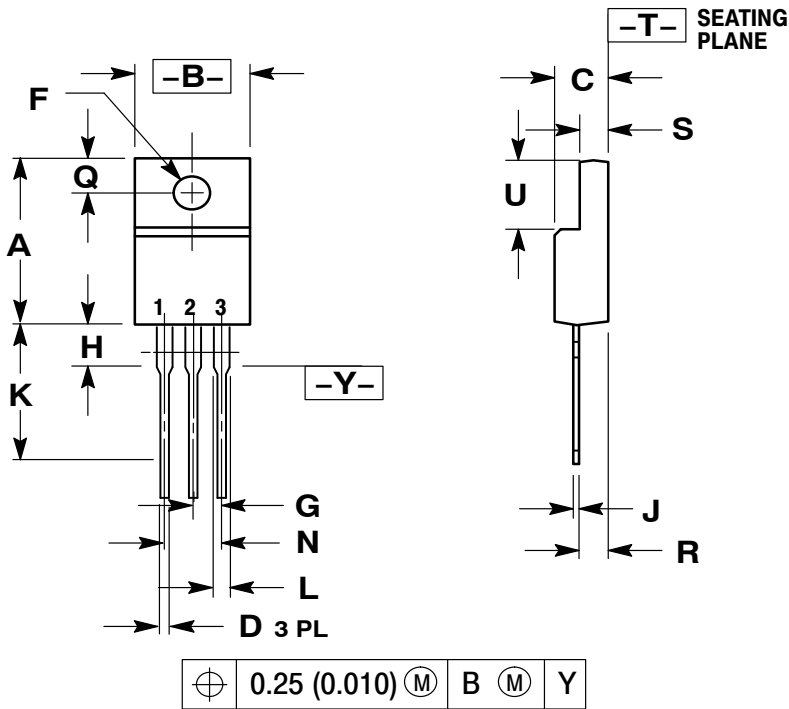

NOTES:

1. DIMENSIONING AND TOLERANCING PER ANSI Y14.5M, 1982.
2. CONTROLLING DIMENSION: INCH
3. 221D-01 THRU 221D-02 OBSOLETE, NEW STANDARD 221D-03.

| DIM | INCHES | | MILLIMETERS | |
|-----|-----------|-------|-------------|-------|
| | MIN | MAX | MIN | MAX |
| A | 0.617 | 0.635 | 15.67 | 16.12 |
| B | 0.392 | 0.419 | 9.96 | 10.63 |
| C | 0.177 | 0.193 | 4.50 | 4.90 |
| D | 0.024 | 0.039 | 0.60 | 1.00 |
| F | 0.116 | 0.129 | 2.95 | 3.28 |
| G | 0.100 BSC | | 2.54 BSC | |
| H | 0.118 | 0.135 | 3.00 | 3.43 |
| J | 0.018 | 0.025 | 0.45 | 0.63 |
| K | 0.503 | 0.541 | 12.78 | 13.73 |
| L | 0.048 | 0.058 | 1.23 | 1.47 |
| N | 0.200 BSC | | 5.08 BSC | |
| Q | 0.122 | 0.138 | 3.10 | 3.50 |
| R | 0.099 | 0.117 | 2.51 | 2.96 |
| S | 0.092 | 0.113 | 2.34 | 2.87 |
| U | 0.239 | 0.271 | 6.06 | 6.88 |

X-ON Electronics

Largest Supplier of Electrical and Electronic Components

Click to view similar products for [MOSFET](#) category:

Click to view products by [First Semicon](#) manufacturer:

Other Similar products are found below :

[614233C](#) [648584F](#) [FDPF9N50NZ](#) [IRFD120](#) [IRFF430](#) [JANTX2N5237](#) [2N7000](#) [FCA20N60_F109](#) [FDZ595PZ](#) [2SK2267\(Q\)](#) [2SK2545\(Q,T\)](#)
[405094E](#) [423220D](#) [MIC4420CM-TR](#) [VN1206L](#) [614234A](#) [715780A](#) [SSM6J414TU,LF\(T](#) [751625C](#) [PSMN4R2-30MLD](#)
[TK31J60W5,S1VQ\(O](#) [2SK2614\(TE16L1,Q\)](#) [DMN1017UCP3-7](#) [EFC2J004NUZTDG](#) [FCAB21350L1](#) [P85W28HP2F-7071](#) [DMN1053UCP4-7](#)
[NTE2384](#) [NTE2969](#) [NTE6400A](#) [DMN61D9UWQ-13](#) [US6M2GTR](#) [DMN31D5UDJ-7](#) [SSM6P54TU,LF](#) [DMP22D4UFO-7B](#)
[IPS60R3K4CEAKMA1](#) [DMN1006UCA6-7](#) [DMN16M9UCA6-7](#) [STF5N65M6](#) [STU5N65M6](#) [C3M0021120D](#) [DMN13M9UCA6-7](#)
[BSS340NWH6327XTSA1](#) [MCM3400A-TP](#) [DMTH10H4M6SPS-13](#) [IPS60R1K0PFD7SAKMA1](#) [IPS60R360PFD7SAKMA1](#)
[IPS60R600PFD7SAKMA1](#) [IPS60R210PFD7SAKMA1](#) [DMN2990UFB-7B](#)