

fischer elektronik

to cool to protect to connect



f.cool.e 15/16

made
in
Germany



ISO 9001
ISO 14001
ISO 27001

Extruded heatsinks LED heatsinks Cooling aggregates

The information given in this catalogue were established and examined carefully. Nevertheless, mistakes or printing errors, and especially technical modifications and updating and improvement of our products, cannot be excluded. All trade marks are recognised even if they are not specifically identified or mentioned. No identification does not imply that a product or trademark is not registered. No part of this catalogue may be reproduced or distributed without prior written consent of Fischer Elektronik. All data contained in this catalogue, in texts, illustrations, documents and descriptions are subject to copyright and the provisions of DIN ISO 16016. All rights reserved.

© Copyright Fischer Elektronik 1969 ... 2014

Fischer Elektronik GmbH & Co. KG

P.O. Box 1590
D-58465 Lüdenscheid

House Address



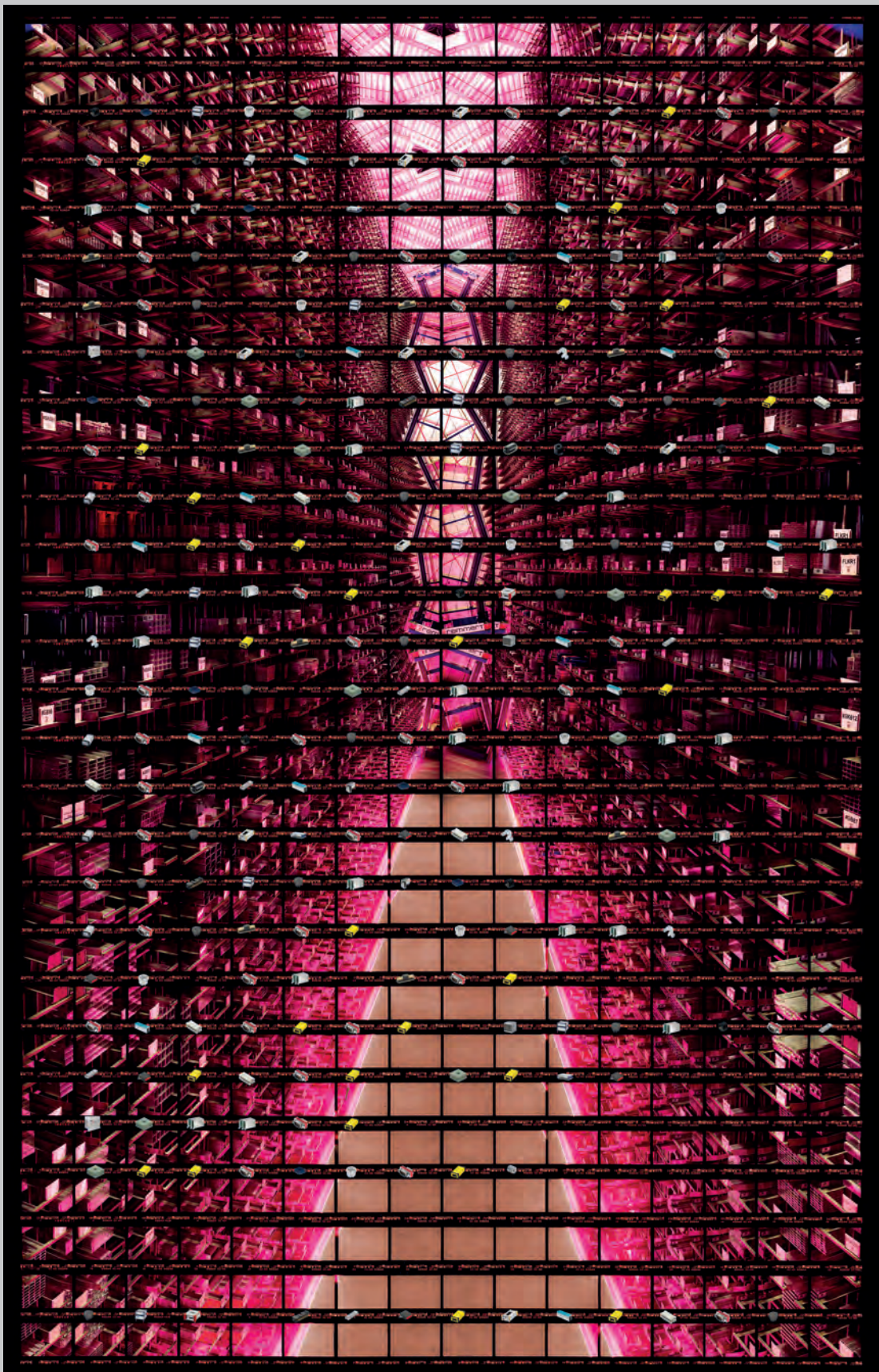







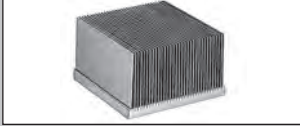

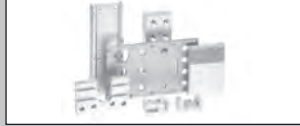

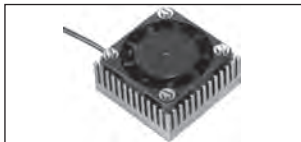







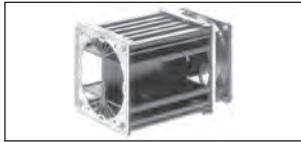
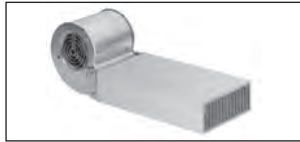

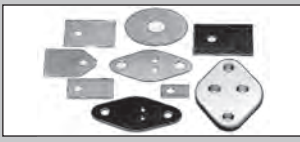

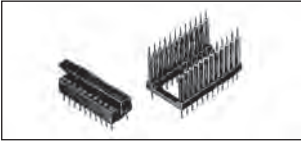
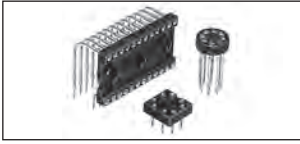
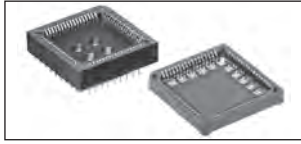

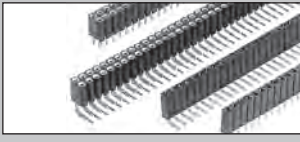

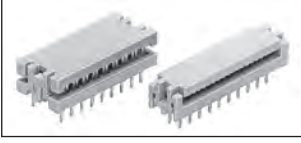







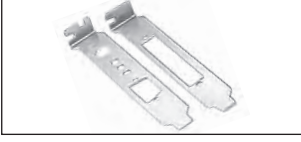
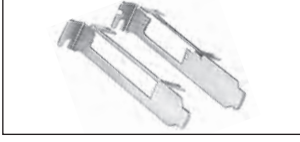

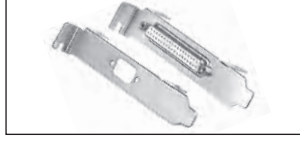

Nottebohmstr. 28
D-58511 Lüdenscheid
Fon: +49 (0) 23 51 4 35-0
Fax: sales +49 (0) 23 51 4 57 54
purchasing +49 (0) 23 51 45 94 33
exports +49 (0) 23 51 43 51 85
info@fischerelektronik.de
www.fischerelektronik.de



Quotations for Fischer Elektronik 3

C-print on Alu Dibond 65,5 x 98 cm

from:
Thomas Kellner
www.thomaskellner.com

A	A 1 - A 140				
B	B 1 - B 62				
C	C 1 - C 22				
D	D 1 - D 36				
E	E 1 - E 52				
F	F 1 - F 28				
G	G 1 - G 84				
H	H 1 - H 12				
I	I 1 - I 28				
K	K 1 - K 28				
L	L 1 - L 10				
M	M 1 - M 56				
N	N 1 - N 80				

Extruded profiles:

extruded heatsinks, extruded heatsinks with solder pins, fin coolers, fluid coolers, high-performance heatsinks

A 1
–
A 140

A

Heatsinks for processors and LED:

heatsinks and fan coolers for universal PGA/BGA, DIL, PLCC, Intel Pentium Xeon, Intel Pentium IV, heatsinks for LED

B 1
–
B 62

B

Board level heatsinks:

finger-shaped heatsinks, heatsinks for transistors in plastic case, attachable heatsinks, small heatsinks, copper heatsinks for D PAK and others

C 1
–
C 22

C

Cooling aggregates:

miniature cooling aggregates, heatsink cooling aggregates, high capacity cooling aggregates, multi module cooling aggregates, hollow-fin aggregates

D 1
–
D 36

D

Accessories for electronic components:

mounting parts for heatsinks, thermal transfer compound, thermally conductive material, aluminium oxide and mica wafers, silicone washers, guide rails, solder stop plug, clip fastening for mounting rail

E 1
–
E 50

E

Sockets:

IC-sockets for DIL, PLCC, sockets for transistors, LED displays, crystal oscillators and connector-sleeves

F 1
–
F 28

F

PCB connectors and accessories:

male and female headers, grid spacing 2.54, 2.00 and 1.27 mm, high precision contact strips, jumpers

G 1
–
G 84

G

IDC connectors:

design DIL, single and double row female headers, lockable connectors, ribbon cable

H 1
–
H 12

H

D-Sub connectors:

male and female headers, connectors with mounting angle, connectors for ribbon cable, SMD and mixed layout, D-Sub shells, cut-out covers

I 1
–
I 28

I

Brackets:

brackets for PC and PCI with or without fixing tab, retainer for ISA versions

K 1
–
K 32

K

Optoelectronics:

LED-holders for front panel assembly, LED-holder without LED, LED-holder with mounted LED, light pipes for SMDs

L 1
–
L 10

L

Cases:

desk consoles, shell cases, extruded assembled cases, combination cases, tube cases, miniature aluminium cases, design cases, cooling cases, ventilation frames, feet and bushings, special front panels, sheet constructions

M 1
–
M 56

M

19" Extension systems:

plug-in chassis, subracks, bench cases, system cases, insert modules, part front panels, rack handles, PC-board holder, extender cards

N 1
–
N 80

N

Alphanumerical product list

art. no.	page	art. no.	page	art. no.	page	art. no.	page
ABM 2550	E 38	DR 135 VO	E 40	FK 232 220	C 8	FS 6 100	E 27
ABM 3050	E 38	DR 140 VO	E 40	FK 233 220	C 8	FS 6 110	E 27
ABM 4070	E 38	DR 145 VO	E 40	FK 234 SA L 1	C 4	FS 6 120	E 27
ABM 5080	E 38	DR 150 VO	E 40	FK 234 SA L 2	C 4	FS 6 130	E 27
ABM TE 04	E 39	DR 710 VO	E 40	FK 234 SA L 3	C 4	FS 85	E 28
ABM TE 04 DIN	E 39	DR 711 VO	E 40	FK 234 SA L 4	C 4	FS 85 50	E 28
ABM TE 06	E 39	DR 712 VO	E 40	FK 235 MI L 1	C 4	FS 85 60	E 28
ABM TE 06 DIN	E 39	DR 713 VO	E 40	FK 235 MI L 2	C 4	FS 85 70	E 28
ABM TE 08	E 39	DR 714 VO	E 40	FK 235 SA L 1	C 4	FS 100	E 27
ABM TE 08 DIN	E 39	DR 715 VO	E 40	FK 235 SA L 2	C 4	FS 109	E 27
ABP 2550	E 38	DR 720 VO	E 40	FK 236 220	C 9	FS 151 P	E 26
ABP 3060	E 38	DR 725 VO	E 40	FK 236 CB	C 9	FS BF 06	E 29
ABP 4080	E 38	DR 730 VO	E 40	FK 237 SA 220 H	C 14	FS BF 07	E 29
AHG K 27	E 31	DR 735 VO	E 40	FK 237 SA 220 O	C 13	FS BF 10	E 29
AHG K 28	E 31	DR 740 VO	E 40	FK 237 SA 220 V	C 14	FS BF 11	E 29
AHG L 7	E 31	DR 745 VO	E 40	FK 237 SA 220 VL	C 14	FS BF 13	E 29
AHG V 14	E 31	DR 750 VO	E 40	FK 238 SA L 1	C 8	FS BF 15	E 29
AHG V 17	E 31	DR 760 VO	E 40	FK 239 SA 32	C 6	FS BF 19	E 29
AHM 3260	E 39	DR 810 VO	E 40	FK 240 SA 220 H	C 14	FS BF 20	E 29
AHM 4380	E 39	DR 811 VO	E 40	FK 240 SA 220 O	C 13	FS BT 06	E 29
AKK 127	A 125	DR 812 VO	E 40	FK 240 SA 220 V	C 14	FS BT 08	E 29
AKK 191	A 125	DR 813 VO	E 40	FK 240 SA 220 VL	C 14	FS BT 10	E 29
AOS 3	E 17	DR 814 VO	E 40	FK 241 SA 218 V	C 11	FS BT 11	E 29
AOS 3 P	E 17	DR 815 VO	E 40	FK 242 SA 220 H	C 14	FS BT 13	E 29
AOS 3 P 2	E 17	DR 820 VO	E 40	FK 242 SA 220 O	C 13	FS BT 15	E 29
AOS 3 P SL	E 17	DR 825 VO	E 40	FK 242 SA 220 V	C 14	FS BT 16	E 29
AOS 5	E 17	DR 830 VO	E 40	FK 242 SA 220 VL	C 14	FS BT 19	E 29
AOS 18	E 17	DR 835 VO	E 40	FK 243 MI 247 H	C 12	FS BT 20	E 29
AOS 32	E 17	DR 840 VO	E 40	FK 243 MI 247 O	C 12	FSF 52 P	E 20
AOS 66	E 17	DR 845 VO	E 40	FK 243 MI 247 V	C 12	FS LP 05	E 30
AOS 93	E 17	DR 850 VO	E 40	FK 244 08 D2 PAK	C 21	FS LP 07	E 30
AOS 127	E 17	DR 860 VO	E 40	FK 244 08 D3 PAK	C 21	FS LP 08	E 30
AOS 218 247	E 17	ELS 3	A 88	FK 244 08 D PAK	C 21	FS LP 10	E 30
AOS 218 247 1	E 17	EPN 1	E 44	FK 244 13 D2 PAK	C 21	FS LP 11	E 30
AOS 220	E 17	FK 201 SA	C 2	FK 244 13 D3 PAK	C 21	FS LP 13	E 30
AOS 220 3	E 17	FK 201 SA 3	C 2	FK 244 13 D PAK	C 21	FS LP 15	E 30
AOS 220 4	E 17	FK 201 SA CB	C 2	FK 245 MI 247 H	C 12	FS LP 16	E 30
AOS 220 SL	E 17	FK 202 SA	C 2	FK 245 MI 247 O	C 12	FS LP 17	E 30
AOS 247	E 17	FK 202 SA 3	C 2	FK 245 MI 247 V	C 12	FS LP 22	E 30
AOS P 1	E 18	FK 202 SA CB	C 2	FK 247 220	C 7	FS LP 30	E 30
AOS P 1.1	E 18	FK 205 SA L	C 2	FK 248 SA 220	C 11	FS S 06 2	E 29
AOS P 2	E 18	FK 206 SA L	C 2	FK 249 SA 220	C 5	FS S 07 2	E 29
AOS P 3	E 18	FK 207 SA L	C 2	FK 250 06 LF PAK	C 22	FS S 08 2	E 29
AOS P 4	E 18	FK 208 SA L	C 2	FK 250 08 LF PAK	C 22	FS S 10 2	E 29
AOS P 5	E 18	FK 209 SA 32	C 6	FK 250 10 LF PAK	C 22	FS S 11 2	E 29
AOS P 6	E 18	FK 210 SA CB	C 6	FK 251 06 LF PAK	C 22	FS S 12 2	E 29
AOS P 7	E 18	FK 211 32	C 7	FK 251 08 LF PAK	C 22	FS S 13 2	E 29
AOS P 8	E 18	FK 212 CB	C 7	FK 251 10 LF PAK	C 22	FS S 15 2	E 29
AOS P 9	E 18	FK 213 SA 32	C 6	FK 252 SA 220 H	C 15	FS S 16 2	E 29
AOS P 10	E 18	FK 214 SA CB	C 6	FK 252 SA 220 O	C 15	FS S 19 3	E 29
CLIP 151	E 26	FK 215 32	C 7	FK 252 SA 220 V	C 15	FS S 20 3	E 29
DR 071 VO	E 40	FK 216 CB	C 7	FK 252 SA 220 VL	C 15	FS S 21 2	E 29
DR 072 VO	E 40	FK 217 SA CB 2	C 3	FK 253	C 16	FS S 21 3	E 29
DR 073 VO	E 40	FK 218 32	C 8	FK 254 SA 3	C 2	FS U 06	E 30
DR 074 VO	E 40	FK 219 CB 1	C 9	FK 255	C 16	FS U 11	E 30
DR 075 VO	E 40	FK 219 CB 2	C 9	FK 256	C 22	FS U 20	E 30
DR 076 VO	E 40	FK 219 CB 3	C 9	FK 257	C 16	GBM 2550	E 37
DR 077 VO	E 40	FK 220 SA 220	C 10	FK 258 SA 220	C 10	GBM 3050	E 37
DR 078 VO	E 40	FK 222	C 7	FK 318 SA	C 2	GBM 4070	E 37
DR 079 VO	E 40	FK 222 THF	C 7	FK 318 SA 3	C 2	GBM 5080	E 37
DR 081 VO	E 40	FK 223 SA	C 3	FL 0,55	A 128	GBP 3060	E 37
DR 082 VO	E 40	FK 223 SA 3	C 3	FL 1,1	A 128	GBP 4080	E 37
DR 083 VO	E 40	FK 223 SA CB	C 3	FLKI 80	A 131	GEL ...	E 12
DR 084 VO	E 40	FK 224 ... 218 1	C 11	FLKI 80 G 200	A 132	GEL G ...	
DR 085 VO	E 40	FK 224 ... 218 2	C 11	FLKI 80 G 300	A 132	GEL 27 S ...	E 15
DR 086 VO	E 40	FK 224 ... 220 1	C 11	FLKI 80 G 500	A 132	GEL 28 ...	E 13
DR 087 VO	E 40	FK 224 ... 220 2	C 11	FLKR 1	A 133	GEL 28 G ...	
DR 088 VO	E 40	FK 224 ... P SIP	C 10	FLKU 140	A 131	GEL 45 ...	E 14
DR 089 VO	E 40	FK 225 SA L 1	C 5	FLKU 140 G 200	A 132	GEL 45 G ...	
DR 105 VO	E 40	FK 225 SA L 2	C 5	FLKU 140 G 300	A 132	GEL 60 ...	E 15
DR 110 VO	E 40	FK 227 SA L 1	C 8	FLKU 140 G 500	A 132	GEL 60 G ...	
DR 115 VO	E 40	FK 228 SA L 1	C 5	FS 6 065	E 27	GEL F 15 ...	E 11
DR 120 VO	E 40	FK 229 SA L 1	C 5	FS 6 070	E 27	GEL F 15 G ...	
DR 125 VO	E 40	FK 230 SA L 1	C 5	FS 6 080	E 27	GS 3	E 19
DR 130 VO	E 40	FK 231 SA 220	C 6	FS 6 090	E 27	GS 3 P	E 19

Alphanumerical product list

art. no.	page	art. no.	page	art. no.	page	art. no.	page
GS 3 P SL	E 19	ICK LED R 23,5 x 14 G	B 35	ICK S 10 x 10 x 12,5	B 21	ICK SMD K 10 SA	B 54
GS 32 P	E 19	ICK LED R 27 x 10	B 35	ICK S 10 x 10 x 18,5	B 22	ICK SMD K 13	B 54
GS 66 P	E 19	ICK LED R 27 x 10 G	B 35	ICK S 14 x 14 x 6,5	B 22	ICK SMD K 17	B 54
GS 218	E 19	ICK LED R 28 x 15	B 35	ICK S 14 x 14 x 10	B 22	ICK SMD K 19	B 54
GS 220 4	E 19	ICK LED R 28 x 15 G	B 36	ICK S 14 x 14 x 12,5	B 22	ICK SMD K 21	B 54
GS 220 C	E 19	ICK LED R 29 x 11,5	B 36	ICK S 14 x 14 x 18,5	B 22	ICK SMD M 8 SA	B 54
GS 220 P	E 19	ICK LED R 29 x 11,5 G	B 36	ICK S 17 x 17 x 15	B 22	ICK SMD M 10 SA	B 54
IB 1	E 52	ICK LED R 32 x 14	B 36	ICK S 17 x 17 x 20	B 23	ICK SMD M 17 MI	B 54
IB 2	E 52	ICK LED R 32 x 14 G	B 36	ICK S 18 x 18 x 6,5	B 23	ICK SMD M 19 SA	B 54
IB 3	E 52	ICK LED R 33 x 10	B 36	ICK S 18 x 18 x 10	B 23	ICK SMD M 21 SA	B 54
IB 4	E 52	ICK LED R 33 x 10 G	B 36	ICK S 22 x 22 x 10	B 23	ICK SMD N 8	B 55
IB 5	E 52	ICK LED R 33 x 16,5	B 37	ICK S 22 x 22 x 18,5	B 23	ICK SMD N 10	B 55
IB 6	E 52	ICK LED R 33 x 16,5 G	B 37	ICK S 25 x 25 x 6,5	B 23	ICK SMD N 17	B 55
IB 7	E 52	ICK LED R 35 x 10	B 37	ICK S 25 x 25 x 12,5	B 24	ICK SMD N 19	B 55
IB 8	E 52	ICK LED R 35 x 10 G	B 37	ICK S 25 x 25 x 18,5	B 24	ICK SMD N 21	B 55
IB 9	E 52	ICK LED R 36 x 12	B 37	ICK S 29 x 29 x 10	B 24	ICK SMD N 26	B 55
IB 10	E 52	ICK LED R 36 x 12 G	B 37	ICK S 29 x 29 x 20	B 24	ICK S R 28,5 x 6,5	B 29
IB 11	E 52	ICK LED R 40 x 10	B 37	ICK S 29 x 29 x 30	B 24	ICK S R 28,5 x 10	B 29
IB 12	E 52	ICK LED R 40 x 10 G	B 38	ICK S 32 x 32 x 10	B 24	ICK S R 28,5 x 12,5	B 29
IB 13	E 52	ICK LED R 40 x 27	B 38	ICK S 32 x 32 x 20	B 25	ICK S R 28,5 x 18,5	B 29
IB 14	E 52	ICK LED R 40 x 27 G	B 38	ICK S 36 x 36 x 10	B 25	ICK S R 32,5 x 10	B 29
IB 15	E 52	ICK LED R 45,7 x 16,5	B 38	ICK S 36 x 36 x 15	B 25	ICK S R 32,5 x 20	B 29
IB 16	E 52	ICK LED R 45,7 x 16,5 G	B 38	ICK S 36 x 36 x 20	B 25	ICK S R 32,5 x 30	B 30
IB 17	E 52	ICK LED R 50,8 x 16,5	B 39	ICK S 36 x 36 x 30	B 25	ICK S R 32,5 x 40	B 30
IB 18	E 52	ICK LED R 50,8 x 16,5 G	B 39	ICK S 40 x 40 x 10	B 25	ICK S R 32,5 x 50	B 30
IBT 1	E 52	ICK LED R 50 x 10	B 38	ICK S 40 x 40 x 20	B 26	ICK S R 36,5 x 20	B 30
IBT 2	E 52	ICK LED R 50 x 10 G	B 39	ICK S 40 x 40 x 25	B 26	ICK S R 40 x 10	B 30
IBT 3	E 52	ICK LED R 54 x 20	B 39	ICK S 45 x 45 x 10	B 26	ICK S R 40 x 20	B 30
IBT 4	E 52	ICK LED R 54 x 20 G	B 39	ICK S 45 x 45 x 20	B 26	ICK S R 40 x 30	B 31
IBT 6	E 52	ICK LED R 66 x 40	B 39	ICK S 50 x 50 x 20	B 26	ICK S R 40 x 50	B 31
IBT 7	E 52	ICK LED R 75 x 10	B 40	ICK S 50 x 50 x 25	B 26	ICK S R 45 x 30	B 31
IBT 8	E 52	ICK LED R 84 x 40	B 40	ICK S 50 x 50 x 40	B 27	ICK S R 45 x 45	B 31
IBT 9	E 52	ICK LED R 100 x 40	B 40	ICK S 50 x 50 x 50	B 27	ICK S R 50 x 10	B 31
IBT 10	E 52	ICK LED R 160 x 40	B 40	ICK S 98 x 98 x 30	B 27	ICK S R 50 x 20	B 32
IBT 11	E 52	ICK LED R 200 x 40	B 41	ICK S 98 x 98 x 45	B 27	ICK S R 50 x 30	B 32
IBT 12	E 52	ICK PEN 3 FC	B 57	ICK S D 12 x 12 x 7,5	B 28	ICK S R 50 x 45	B 32
IBT 14	E 52	ICK PEN 3 XE	B 56	ICK S D 18 x 12 x 7,5	B 28	ICK S R 54 x 20	B 32
IBT 15	E 52	ICK PEN 3 XE 1	B 56	ICK S D 24 x 18 x 7,5	B 28	ICK S R 54 x 30	B 32
IBT 18	E 52	ICK PEN 38 F	B 57	ICK S D 98 x 98 x 10	B 28	ICK S R 54 x 45	B 33
ICK 6 8 L	B 52	ICK PEN 38 W	B 57	ICK SMD A 5	B 53	ICK S R 70 x 30	B 33
ICK 14 16 B	B 52	ICK PEN 45 W	B 57	ICK SMD A 8	B 53	ICK S R 70 x 50	B 33
ICK 14 16 L	B 52	ICK PGA 6 x 6 x 14	B 11	ICK SMD A 10	B 53	ICK S R 85 x 30	B 33
ICK 14 H	B 52	ICK PGA 8 x 8 x 12	B 11	ICK SMD A 13	B 53	ICK S R 85 x 45	B 33
ICK 16 H	B 52	ICK PGA 9 x 9	B 11	ICK SMD A 17	B 53	ICK S R 98 x 30	B 34
ICK 18 H	B 52	ICK PGA 11 x 11	B 11	ICK SMD A 22	B 53	ICK S R 98 x 50	B 34
ICK 20 L	B 52	ICK PGA 11 x 11 x 8	B 11	ICK SMD B 5	B 53	ICK S R A 40 x 20	B 31
ICK 24 B	B 52	ICK PGA 11 x 11 x 12	B 12	ICK SMD B 7 SA	B 53	IK 3	E 51
ICK 28 B	B 52	ICK PGA 14 x 14	B 12	ICK SMD B 10 SA	B 53	IK 341 3	E 51
ICK 35 SA	A 124	ICK PGA 14 x 14 x 10	B 12	ICK SMD B 13 SA	B 53	IS 1	E 49
ICK 36 B	B 52	ICK PGA 14 x 14 x 12	B 12	ICK SMD B 19	B 53	IS 2	E 49
ICK 40 B	B 52	ICK PGA 14 x 14 x 14	B 12	ICK SMD BOX 1	B 55	IS 3	E 49
ICK 1000 B	B 52	ICK PGA 15 x 15	B 12	ICK SMD C 7 SA	B 53	IS 4	E 49
ICK 1000 H	B 52	ICK PGA 16 x 16 x 8	B 13	ICK SMD C 10 SA	B 53	IS 5	E 49
ICK BGA 10 x 10	B 17	ICK PGA 16 x 16 x 10	B 13	ICK SMD C 17	B 53	IS 6	E 49
ICK BGA 10 x 10 x 10	B 17	ICK PGA 16 x 16 x 12	B 13	ICK SMD E 15 SA	B 54	IS 7	E 50
ICK BGA 14 x 14	B 17	ICK PGA 17 x 17	B 13	ICK SMD E 22 SA	B 54	IS 8	E 50
ICK BGA 14 x 14 x 10	B 17	ICK PGA 17 x 17 x 8	B 13	ICK SMD E 29 SA	B 54	IS 53	A 127
ICK BGA 21 x 21	B 18	ICK PGA 17 x 17 x 12	B 13	ICK SMD F 8	B 54	ISAB 3 A	E 32
ICK BGA 23 x 23	B 18	ICK PGA 18 x 18	B 14	ICK SMD F 10	B 54	ISAB 3 B	E 33
ICK BGA 23 x 23 x 10	B 18	ICK PGA 19 x 19	B 14	ICK SMD F 17 SA	B 54	ISAB 3 C	E 33
ICK BGA 27 x 27	B 18	ICK PGA 19 x 19 x 12	B 14	ICK SMD F 19	B 54	ISAB 4 A	E 32
ICK BGA 27 x 27 x 10	B 18	ICK PGA 20 x 20	B 14	ICK SMD F 21	B 54	ISAB 4 B	E 33
ICK BGA 27 x 27 x 14	B 18	ICK PGA 20 x 20 K	B 15	ICK SMD F 26	B 54	ISAB 4 C	E 33
ICK BGA 27 x 27 x 22	B 19	ICK PGA 20 x 20 x 8	B 15	ICK SMD G 8 MI	B 54	ISAB 5 B	E 33
ICK BGA 31 x 31	B 19	ICK PGA 20 x 20 x 10	B 14	ICK SMD G 10	B 54	ISAB 5 C	E 33
ICK BGA 31 x 31 x 10	B 19	ICK PGA 20 x 20 x 12	B 15	ICK SMD G 13 SA	B 54	ISAB 6 A	E 32
ICK BGA 35 x 35	B 19	ICK PGA 21 x 21	B 15	ICK SMD G 17 SA	B 54	ISAB 6 B	E 33
ICK BGA 35 x 35 x 10	B 19	ICK PGA 22 x 22	B 15	ICK SMD G 19 SA	B 54	ISAB 6 C	E 33
ICK BGA 37 x 37 x 6	B 19	ICK PGA 25 x 25	B 16	ICK SMD G 21	B 54	ISAB 25 A	E 32
ICK BGA 37 x 37 x 10	B 20	ICK PLCC 28	B 52	ICK SMD H 8	B 54	ISAB 25 B	E 33
ICK BGA 40 x 40	B 20	ICK PPC 51	B 56	ICK SMD H 10	B 54	ISAB 25 C	E 33
ICK BGA 40 x 40 x 10	B 20	ICK PRO 40 W	B 57	ICK SMD H 17	B 54	ISAM 2 A	E 34
ICK BGA 42,5 x 45	B 20	ICK R	B 52	ICK SMD H 19 SA	B 54	ISAM 2 B	E 34
ICK EM 25	B 56	ICK S 10 x 10 x 6,5	B 21	ICK SMD H 25	B 54	ISAM 2 C	E 34
ICK LED R 23,5 x 14	B 35	ICK S 10 x 10 x 10	B 21	ICK SMD K 8	B 54	ISAM 3 A	E 34

Alphanumerical product list

art. no.	page	art. no.	page	art. no.	page	art. no.	page
ISAM 3 B	E 34	LA 2 09	D 7	LA V 11	D 18	SFP 054	A 135
ISAM 3 C	E 34	LA 2 10	D 7	LA V 14	D 20	SFP 057	A 135
ISAS 25 A	E 35	LA 4	D 14	LA V 15	D 20	SFP 058	A 135
ISAS 25 B	E 36	LA 5	D 14	LA V 17	D 22	SFP 060	A 135
ISAS 25 C	E 36	LA 6	D 15	LA V 18	D 22	SFP 067	A 135
ISAS 30 A	E 35	LA 7	D 15	LA V 21	D 24	SFP 074	A 135
ISAS 30 B	E 36	LA 8	D 15	LA V 22	D 24	SFP 076	A 135
ISAS 30 C	E 36	LA 9	D 17	LA V 24	D 25	SFP 079	A 135
ISAS 40 A	E 35	LA 10	D 17	LS 101	E 43	SFP 090	A 135
ISAS 40 B	E 36	LA 11	D 17	LS 102	E 43	SFP 100	A 135
ISAS 40 C	E 36	LA 14	D 19	LS 103	E 43	SFP 106	A 135
ISAS 50 A	E 35	LA 15	D 19	LS 104	E 43	SFP 112	A 135
ISAS 50 B	E 36	LA 17	D 21	LS 105	E 43	SK 01	A 66
ISAS 50 C	E 36	LA 18	D 21	LS 106	E 43	SK 02	A 66
ISAS 60 A	E 35	LA 20	D 34	LS 107	E 43	SK 03	A 66
ISAS 60 B	E 36	LA 21	D 23	LSD 07520	E 42	SK 04	A 64
ISAS 60 C	E 36	LA 22	D 23	LSD 08910	E 42	SK 05	A 62
ISP 218	E 45	LA 25	D 33	LSD 08920	E 42	SK 06	A 79
ISP 220	E 45	LA 26	D 33	LSD 13510	E 42	SK 07	A 72
ISP 220 V	E 45	LA 27 K	D 13	LSD 13520	E 42	SK 08	A 73
ISP 247	E 45	LAGI 40	D 36	MD A 04	E 48	SK 09	A 59
K 0,55	A 128	LAGI 60	D 36	MD A 06	E 48	SK 11	A 79
K 1,1	A 128	LAGI 80	D 36	MD A 07	E 48	SK 12	A 123
K 3	A 126	LAGI 92	D 36	MD A 09	E 48	SK 12 SA 2 x 32	A 124
K 3 T	A 126	LAGI 119	D 36	MD A 12	E 48	SK 12 SA 32	A 124
K 5	A 126	LA HL 1	D 27	MD B 07	E 48	SK 13	A 123
K 9	A 126	LA HL 2	D 27	MD B 10	E 48	SK 13 35 SA 220	A 124
K 15	A 127	LA HL 3	D 27	MD B 11	E 48	SK 13 35 SA 220 3,2	A 124
KAP 1 P	E 16	LAHL D 1	D 29	MD B 12	E 48	SK 13 35 SA 220 3,5	A 124
KAP 3 G	E 16	LAHLR 1 500	D 35	MD B 15	E 48	SK 14	A 67
KAP 3 K	E 16	LA HLV 1	D 28	MD C 13	E 48	SK 15	A 77
KAP 218	E 16	LA HLV 2	D 28	MD C 22	E 48	SK 16	A 72
KAP 218 O	E 16	LA HLV 3	D 28	MLW 32	E 47	SK 18	A 62
KAP 220 G	E 16	LA ICK 15 x 15 F 05	B 58	MLW 44	E 47	SK 19	A 63
KAP 220 K	E 16	LA ICK 15 x 15 F 12	B 58	MLW 51	E 47	SK 20	A 68
KAP 220 O	E 16	LA ICK 17 x 17 F 12	B 58	MRL 20	E 47	SK 21	A 70
KAP 247 O	E 16	LA ICK 17 x 17 F 12 A	B 58	MS 34 518	E 46	SK 23	A 79
KF 5/10	C 18	LA ICK 17 x 17 W 05	B 58	MS 53 3	E 46	SK 25	A 61
KF 5/15	C 18	LA ICK 17 x 17 W 12	B 58	MS 53 7	E 46	SK 28	A 63
KF 5/5	C 18	LA ICK 18 x 18 F 12	B 58	MS 53 25	E 46	SK 30	A 67
KK 1 3,96	C 17	LA ICK 18 x 18 W 12	B 58	MS 54 25	E 46	SK 31	A 72
KK 1 6,35	C 17	LA ICK 21 x 21 F 05	B 58	MS 56 15	E 46	SK 32	A 76
KK 1 12,7	C 17	LA ICK 21 x 21 F 12	B 58	MS 58 5	E 46	SK 33	A 42
KK 1 19,05	C 17	LA ICK 21 x 21 W 05	B 58	MS 58 7	E 46	SK 34	A 67
KK 32	C 19	LA ICK 21 x 21 W 12	B 58	MS 58 15	E 46	SK 36	A 66
KK 92	C 19	LA ICK PEN 2 K 12	B 60	MS 84 4	E 46	SK 39	A 67
KK 562 GS	C 18	LA ICK PEN 3 XE	B 60	MS 183 7	E 46	SK 40	A 82
KL 35 50	E 25	LA ICK PEN 4 1 K	B 60	MS 183 25	E 46	SK 42	A 49
KL 35 75	E 25	LA ICK PEN 8 F 05	B 59	MS 183 35	E 46	SK 44	A 90
KL 35 100	E 25	LA ICK PEN 8 F 12	B 59	MS 184 7	E 46	SK 45	A 63
KL 35 K 40	E 25	LA ICK PEN 8 W 05	B 59	MS 184 25	E 46	SK 46	B 43
KL 35 K 50	E 25	LA ICK PEN 8 W 12	B 59	MS 184 35	E 46	SK 47	A 49
KL 35 K 75	E 25	LA ICK PEN 16 K 12	B 59	MS 510 15	E 46	SK 48	A 73
KL 35 K 100	E 25	LA ICK PEN 16 W 12	B 59	MS 923 25	E 46	SK 49	A 51
KTE 1	A 129	LA ICK PEN 16 W 12 A	B 59	MS 3518 25	E 46	SK 50	A 37
KTE 2	A 129	LA ICK PEN 18 W 12	B 59	MS 3518 35	E 46	SK 51	A 61
KTE R	B 47	LA ICK PEN 38 W 12	B 59	MS 4016	E 46	SK 52	A 74
LA 1 01	D 5	LA ICK PRO 25 F 12	B 59	MSHV 90	E 28	SK 53	A 74
LA 1 02	D 5	LA LED 40 x 30	B 49	MST 3	E 44	SK 55	A 83
LA 1 03	D 5	LA LED 50 x 20	B 49	MST 220	E 44	SK 56	A 54
LA 1 04	D 5	LA LED 50 x 45	B 49	MSTS 3	E 44	SK 57	A 64
LA 1 05	D 5	LA LED 68	B 50	MSTS 220	E 44	SK 58	A 45
LA 1 06	D 5	LAM 1	D 9	MSVL 50	E 28	SK 59	A 60
LA 1 07	D 5	LAM 2	D 9	MSVL 60	E 28	SK 60	A 74
LA 1 08	D 5	LAM 3	D 10	MSVL 70	E 28	SK 61	A 82
LA 1 09	D 5	LAM 3 K	D 10	MSVL 85	E 28	SK 63	A 62
LA 1 10	D 5	LAM 4	D 11	MSVL 100	E 27	SK 64	A 70
LA 2 01	D 7	LAM 4 K	D 11	SFP 005	A 135	SK 65	A 70
LA 2 02	D 7	LAM 5	D 12	SFP 006	A 135	SK 66	A 55
LA 2 03	D 7	LAM 5 K	D 12	SFP 007	A 135	SK 67	A 69
LA 2 04	D 7	LA V 6	D 16	SFP 016	A 135	SK 68	A 89
LA 2 05	D 7	LA V 7	D 16	SFP 028	A 135	SK 69	A 71
LA 2 06	D 7	LA V 8	D 16	SFP 029	A 135	SK 71	A 64
LA 2 07	D 7	LA V 9	D 18	SFP 037	A 135	SK 72	A 63
LA 2 08	D 7	LA V 10	D 18	SFP 046	A 135	SK 73	A 64

Alphanumerical product list

art. no.	page	art. no.	page	art. no.	page	art. no.	page
SK 74	A 71	SK 119	A 47	SK 185 37,5 STS TO 220	A 104	SK 447	A 26
SK 75 25	A 105	SK 120	A 45	SK 185 37,5 TO 220	A 104	SK 448	A 27
SK 75 25 STS TO 220	A 105	SK 121	A 42	SK 185 50 C TO 220	A 104	SK 448 20 1 x M3 L	A 111
SK 75 25 TO 220	A 105	SK 122	A 60	SK 185 50 STC TO 220	A 104	SK 448 40 2 x M3 L	A 111
SK 75 37,5	A 105	SK 124	A 71	SK 185 50 STS TO 220	A 104	SK 448 60 3 x M3 L	A 111
SK 75 37,5 STS TO 220	A 105	SK 125	A 91	SK 185 50 TO 220	A 104	SK 450	A 34
SK 75 37,5 TO 220	A 105	SK 126 25	A 107	SK 187	A 76	SK 451	A 91
SK 75 50	A 105	SK 126 25 2 x M3	A 107	SK 189	A 32	SK 452	A 27
SK 75 50 STS TO 220	A 105	SK 126 25 STS TO 220	A 107	SK 190	A 52	SK 452 20 1 x M3	A 96
SK 75 50 TO 220	A 105	SK 126 25 TO 220	A 107	SK 191	A 56	SK 452 20 2 x M3	A 96
SK 75 75	A 105	SK 126 37,5	A 107	SK 193	A 50	SK 452 40 2 x M3	A 96
SK 75 1000	A 105	SK 126 37,5 2 x M3	A 107	SK 194	A 81	SK 452 40 4 x M3	A 96
SK 76 25	A 105	SK 126 37,5 STS TO 220	A 107	SK 195	A 71	SK 452 60 3 x M3	A 96
SK 76 25 STS TO 220	A 105	SK 126 37,5 TO 220	A 107	SK 197	A 65	SK 452 60 6 x M3	A 96
SK 76 25 TO 220	A 105	SK 126 1000	A 107	SK 198	A 53	SK 452 80 4 x M3	A 96
SK 76 37,5	A 105	SK 128	A 91	SK 199	A 51	SK 452 80 8 x M3	A 96
SK 76 37,5 STS TO 220	A 105	SK 129 ... STC	A 103	SK 400	A 28	SK 452 100 5 x M3	A 96
SK 76 37,5 TO 220	A 105	SK 129 ... STIC		SK 400 20 1 x M3 L	A 111	SK 452 100 10 x M3	A 96
SK 76 50	A 105	SK 129 ... STCB		SK 400 40 2 x M3 L	A 111	SK 453	A 33
SK 76 50 STS TO 220	A 105	SK 129 ... STS	A 103	SK 400 60 3 x M3 L	A 111	SK 454	A 24
SK 76 50 TO 220	A 105	SK 129 ... STIS		SK 401	A 63	SK 454 20 1 x M3	A 96
SK 76 75	A 105	SK 129 ... STSB		SK 402	A 62	SK 454 20 1 x M3 L	A 111
SK 76 1000	A 105	SK 130	A 56	SK 403	A 64	SK 454 20 2 x M3	A 96
SK 78	A 61	SK 132	A 44	SK 404	A 65	SK 454 40 2 x M3	A 96
SK 79	A 73	SK 133	A 44	SK 405	A 47	SK 454 40 2 x M3 L	A 111
SK 80	A 74	SK 134	A 28	SK 406	A 38	SK 454 40 4 x M3	A 96
SK 81	A 41	SK 135	A 39	SK 407	A 39	SK 454 60 3 x M3	A 96
SK 82	A 75	SK 136	A 48	SK 408	A 40	SK 454 60 3 x M3 L	A 111
SK 83	A 79	SK 138	A 91	SK 409 ... STC	A 100	SK 454 60 6 x M3	A 96
SK 84	A 68	SK 139	A 53	SK 409 ... STIC		SK 454 80 4 x M3	A 96
SK 85	A 46	SK 140	A 77	SK 409 ... STCB		SK 454 80 8 x M3	A 96
SK 86	A 75	SK 144	A 82	SK 409 ... STS	A 100	SK 454 100 5 x M3	A 96
SK 88	A 73	SK 145	A 59	SK 409 ... STIS		SK 454 100 10 x M3	A 96
SK 89	A 77	SK 145 25 STC	A 106	SK 409 ... STSB		SK 455	A 33
SK 90	A 48	SK 145 25 STS TO 220	A 106	SK 410	A 44	SK 456	A 30
SK 91	A 52	SK 145 30 STC	A 106	SK 411	A 42	SK 456 20 1 x M3 L	A 111
SK 92	A 41	SK 145 37,5 STS TO 220	A 106	SK 412	A 47	SK 456 40 2 x M3 L	A 111
SK 93	A 56	SK 145 50 STC	A 106	SK 413	A 43	SK 456 60 3 x M3 L	A 111
SK 94	A 49	SK 145 50 STS TO 220	A 106	SK 414	A 90	SK 458	D 30
SK 95 15	A 108	SK 147	A 74	SK 415	A 90	SK 459 ... STC	A 101
SK 95 15 SOT 32 S	A 108	SK 148	A 68	SK 416	A 47	SK 459 ... STIC	
SK 95 15 STS SOT 32 S	A 108	SK 149	A 53	SK 417	A 46	SK 459 ... STCB	
SK 95 25	A 108	SK 150	A 61	SK 418	A 58	SK 459 ... STS	A 101
SK 95 25 1 x M2,5 1 x M3	A 108	SK 153	A 83	SK 419	A 70	SK 459 ... STIS	
SK 95 25 2 x M3	A 108	SK 154	A 46	SK 420	A 31	SK 459 ... STSB	
SK 95 25 SOT 32	A 108	SK 155	A 45	SK 421	A 47	SK 459 25 2 x TO 220	A 102
SK 95 25 STS SOT 32	A 108	SK 156	A 36	SK 422	A 32	SK 459 25 M	A 102
SK 95 25 STS TO 220	A 108	SK 157	A 54	SK 423	A 32	SK 459 37,5 2 x TO 220	A 102
SK 95 25 TO 220	A 108	SK 158	A 58	SK 424	A 34	SK 459 37,5 M	A 102
SK 95 1000	A 108	SK 159	A 58	SK 425	A 34	SK 459 50 2 x TO 220	A 102
SK 96	A 91	SK 160	A 58	SK 426	A 36	SK 459 50 M	A 102
SK 97	A 62	SK 161	A 58	SK 427	A 36	SK 460 25	A 112
SK 98	A 65	SK 162	A 58	SK 429	A 37	SK 460 37,5	A 112
SK 99	A 37	SK 163	A 78	SK 431 1	A 124	SK 460 50	A 112
SK 100	A 38	SK 165	A 61	SK 431 2	A 124	SK 461	D 30
SK 101	A 54	SK 166	A 48	SK 431 3	A 124	SK 463	A 43
SK 102	A 50	SK 168	A 50	SK 432	A 82	SK 464	A 39
SK 104 ... LS	A 98	SK 172	A 81	SK 433	A 41	SK 466	A 43
SK 104 ... STC	A 97	SK 173	A 59	SK 434	A 35	SK 467	A 33
SK 104 ... STIC		SK 174	A 30	SK 435	A 81	SK 468	A 36
SK 104 ... STCB		SK 175	A 83	SK 436	A 37	SK 469	A 23
SK 104 ... STS	A 97	SK 176	A 78	SK 437	A 24	SK 469 ... STS	A 110
SK 104 ... STIS		SK 177	A 27	SK 437 ... STC	A 109	SK 470	A 22
SK 104 ... STSB		SK 178	A 28	SK 437 ... STC 2	A 109	SK 470 25 STS	A 110
SK 105	A 90	SK 179	A 30	SK 437 ... STS	A 109	SK 470 30 STS	A 110
SK 106	A 31	SK 180	A 36	SK 437 ... STS 2	A 109	SK 470 35 STS	A 110
SK 107	A 60	SK 181	A 60	SK 438	A 52	SK 470 50 STS	A 110
SK 108	A 80	SK 181 94 C 3 x TO 220	A 60	SK 439	A 55	SK 471	A 29
SK 109	A 80	SK 182	A 40	SK 440	D 30	SK 472	A 31
SK 110	A 80	SK 184	A 68	SK 441	D 30	SK 473	A 25
SK 111	A 81	SK 185	A 73	SK 442	A 42	SK 475	A 35
SK 112	A 89	SK 185 25 STC TO 220	A 104	SK 443	A 59	SK 476	A 24
SK 113	A 48	SK 185 25 STS TO 220	A 104	SK 444	A 38	SK 477	A 24
SK 115	A 123	SK 185 25 TO 220	A 104	SK 445	A 34	SK 478	A 23
SK 118	A 51	SK 185 37,5 STC TO 220	A 104	SK 446	A 53	SK 479	A 55

Alphanumerical product list

art. no.	page	art. no.	page	art. no.	page	art. no.	page
SK 480	A 84	SK 547	A 31	SK 617	A 88	THFK 247	A 116
SK 481	A 85	SK 548	A 34	SK 618	B 42	THFM	A 116
SK 482	A 86	SK 549	A 29	SK 619	B 42	THFMG	A 116
SK 483	A 87	SK 550	A 27	SK 620	B 42	THFU 1	A 119
SK 484	A 110	SK 551	A 25	SK 621	A 56	THFU 2	A 119
SK 485	A 38	SK 552	A 23	SK DC 2 1 76 SA	A 114	THFU 3	A 120
SK 486	A 25	SK 553	A 44	SK DC 4 1 117 SA	A 113	THFU 4	A 120
SK 487	A 87	SK 554	A 26	SK DC 5 1 59 SA	A 114	THFU 5	A 120
SK 489	A 85	SK 555	A 51	SK DC 5 59 SA	A 114	THFU 6	A 121
SK 490	A 84	SK 556	A 77	SK DC 6 1 60 SA	A 113	THFU 7	A 121
SK 492	A 84	SK 557	A 50	SK DC 7 1 117 SA	A 114	UK 14 SA 220	A 123
SK 493	A 28	SK 558	A 23	SK DC 7 117 SA	A 114	UK 14 SA 220 3,2	A 123
SK 494	A 83	SK 559	A 25	SK DC 8 1 60 SA	A 113	UK 14 SA M3	A 123
SK 495	A 87	SK 560	A 26	SK DC 8 60 SA	A 113	US 58 4	E 46
SK 496	A 22	SK 561	A 26	SK DC 10 60 SA	A 113	US 512 4	E 46
SK 497	D 30	SK 562	A 29	SKK 56	C 19	WB 3	E 4
SK 498	D 30	SK 563	A 30	SKK 58	C 19	WB 3 P	E 4
SK 499	A 87	SK 564	A 30	SKK 510	C 19	WBT 30	E 4
SK 500	A 72	SK 565	A 22	SK LED 1	B 48	WBT 300	E 4
SK 501	A 54	SK 566	A 26	SK LED 2	B 48	WG 3	E 4
SK 502	A 49	SK 567	A 35	SK LED 3	B 48	WG 3 P	E 4
SK 503	A 46	SK 568	A 54	SK LED BOX 1	B 51	WGT 300	E 4
SK 504	A 45	SK 569	B 43	SMP 410 A	E 41	WK 3	E 4
SK 505	A 41	SK 570	B 44	SMP 410 B	E 41	WK 3 P	E 4
SK 507	A 40	SK 571	B 44	SMP 410 C	E 41	WK 3/4	E 4
SK 508	A 41	SK 572	B 44	SMP 415 A	E 41	WKT 24	E 4
SK 509	A 29	SK 573	A 85	SMP 415 B	E 41	WKT 300	E 4
SK 510	A 46	SK 574	A 86	SMP 415 C	E 41	WL 0,55	A 128
SK 511	A 32	SK 575	A 84	SMP 515 A	E 41	WL 1,1	A 128
SK 512	A 84	SK 576	A 85	SMP 515 B	E 41	WLF 9010 R 25	E 9
SK 513	A 31	SK 577	B 43	SMP 515 C	E 41	WLF 9010 R 50	E 9
SK 514	A 86	SK 578	B 43	STP 4	A 136	WLF 9010 R 100	E 9
SK 515 05 10	A 94	SK 579	A 55	STP 5	A 136	WLF 9015 R 25	E 9
SK 515 05 10 S	A 94	SK 580	A 51	SU 02	A 135	WLF 9015 R 50	E 9
SK 515 05 23,5	A 94	SK 581	A 28	SU 03	A 135	WLF 9015 R 100	E 9
SK 515 05 23,5 S 2	A 94	SK 582	A 25	SU 05	A 135	WLF 9020 R 25	E 9
SK 515 05 37	A 94	SK 583	A 53	SU 09	A 135	WLF 9020 R 50	E 9
SK 515 05 37 S 3	A 94	SK 584	B 44	SU 16	A 135	WLF 9020 R 100	E 9
SK 515 10 S TO 220	A 94	SK 585 ...	B 42	SU 27	A 135	WLF 9020 R 25	E 9
SK 515 10 TO 220	A 94	SK 586	A 22	SU 29	A 135	WLF 9020 R 50	E 9
SK 515 23,5 S 2 x TO 220	A 94	SK 587	A 29	SU 32	A 135	WLF 9020 R 100	E 9
SK 515 23,5 TO 220	A 94	SK 588	A 45	SVP 01	A 136	WLF 9020 R 25	E 9
SK 515 37 S 3 x TO 220	A 94	SK 589	A 86	SVP 04	A 136	WLF 9020 R 50	E 9
SK 515 37 TO 220	A 94	SK 590	B 46	SVP 10	A 136	WLF 9020 R 100	E 9
SK 516 15 S TO 218	A 94	SK 591	A 49	SVP 12	A 136	WLF 9020 R 25	E 9
SK 516 15 TO 218	A 94	SK 592	B 45	SVP 13	A 136	WLF 9020 R 50	E 9
SK 516 33 S 2 x TO 218	A 94	SK 593	A 87	SVP 02	A 135	WLF 9020 R 100	E 9
SK 517	A 93	SK 594	A 38	SWP 06	A 135	WLF 9020 R 25	E 9
SK 518	A 93	SK 595	A 43	SWP 10	A 135	WLF 9020 R 50	E 9
SK 519	A 48	SK 596	A 76	SWP 15	A 135	WLF 9020 R 100	E 9
SK 520	A 50	SK 597	A 27	SWP 23	A 135	WLF 9020 R 25	E 9
SK 521	A 24	SK 598	B 42	SWP 25	A 135	WLF 9020 R 50	E 9
SK 522	A 23	SK 599	B 45	SWP 29	A 135	WLF 9020 R 100	E 9
SK 523	A 55	SK 600 ... STC	A 99	SWP 36	A 135	WLF 9020 R 25	E 9
SK 524	A 52	SK 600 ... STIC		SWP 40	A 135	WLF 9020 R 50	E 9
SK 525 15	A 95	SK 600 ... STCB		SWP 55	A 135	WLF 9020 R 100	E 9
SK 525 15 ST	A 95	SK 600 ... STS	A 99	SWP 57	A 135	WLF 9020 R 25	E 9
SK 525 20 ST	A 95	SK 600 ... STIS		TF 3 2	E 50	WLF 9020 R 50	E 9
SK 525 25 ST	A 95	SK 600 ... STSB		THF 104	A 115	WLF 9020 R 100	E 9
SK 525 30	A 95	SK 601	A 44	THF 129 TO 220	A 115	WLF 9020 R 25	E 9
SK 525 30 ST	A 95	SK 602	B 43	THF 220	A 115	WLF 9020 R 50	E 9
SK 526 30 ST	A 95	SK 603	D 31	THF 220 17	A 115	WLF 9020 R 100	E 9
SK 527	A 35	SK 604	D 31	THF 247	A 115	WLF 9020 R 25	E 9
SK 530	A 57	SK 605	D 31	THF 247 4	A 115	WLF 9020 R 50	E 9
SK 531	A 57	SK 606	D 31	THF 249	A 115	WLF 9020 R 100	E 9
SK 533	A 57	SK 607	D 31	THF 409 220 1	A 115	WLF 9020 R 25	E 9
SK 535	A 57	SK 608	D 31	THF 409 220 2	A 115	WLF 9020 R 50	E 9
SK 536	A 57	SK 609	A 92	THF 409 SOT 32	A 115	WLF 9020 R 100	E 9
SK 537	A 57	SK 610	A 92	THF 409 TO 220	A 115	WLF 9020 R 25	E 9
SK 538	A 57	SK 611	A 92	THF 600	A 115	WLF 9020 R 50	E 9
SK 539	A 57	SK 612	A 39	THFA 1	A 117	WLF 9020 R 100	E 9
SK 540	A 57	SK 613	A 43	THFA 2	A 117	WLF 9020 R 25	E 9
SK 544	A 76	SK 614	A 52	THFA 3	A 117	WLF 9020 R 50	E 9
SK 545	A 39	SK 615	B 45	THFA 4	A 117	WLF 9020 R 100	E 9
SK 546	A 40	SK 616	A 22	THFK 220	A 116	WLF 9020 R 25	E 9

Alphanumerical product list

art. no.	page
WSC-220	E 4
WSF 16	E 10
WSF 32	E 10
WSF 635	E 10
WSFS 635	E 10
WSI 220 210	E 5
WSI 220 225	E 5
WSI TO 3 PL	E 5
WSI TOP 3 235	E 5
WSI TOP 3 280	E 5
WSM-220	E 4
WST 30	E 4
WST 36	E 4
WST 85	E 4

Active heatsinks for processors	B 58-61
Aluminium flat-, quadrangular-, angled-, U- & T-profiles	A 135-136
Aluminium oxide wafers	E 17-18
Attachable heatsink	C 10-16
Cooling aggregates with axial fan	D 13-29
Cooling aggregates with radial fan	D 33-35
Die-cast heatsinks	A 125-128
Distance sleeves and spacers	E 32-40
Extruded heatsinks for DC/DC converter	A 113-114
Extruded heatsinks for lock-in retaining spring	A 84-88
Extruded heatsinks for PCB mounting	A 89-112
Fastening for mounting rail	E 25
Fin coolers	A 129
Finger shaped heatsinks	C 2-9
Fluid coolers	A 131-134
Guide rails	E 26-31
Heat conductive foam and gel foils	E 10-15
Heatsinks for BGAs	B 17-20
Heatsinks for DIL-IC, PLCC and SMD	B 52-55
Heatsinks for D PAK and others	C 21-22
Heatsinks for LEDs	B 35-51
Heatsinks for PGA	B 11-16
High-performance heatsinks	D 30-32
High thermoconducting graphite foils	E 9
Insulating caps and insulator sleeves	E 51-52
Insulating clamping parts for power transistors	E 45
Kapton insulator washers	E 16
Mica wafers	E 19
Miniature cooling aggregates	D 9-12
Mounting kits for insulation of power transistors	E 44
Mounting parts for heatsinks	E 49-50
Mounts	E 46-48
Passive heatsinks for processors	B 56-57
Pin heatsinks	B 21-34
Protection grid for fans	D 36
Retaining springs for transistors	A 115-122
Segment cooling aggregates	D 5-9
Small heatsinks	C 17-20
Standard extruded heatsinks	A 22-83
Thermal conductive foil one-sided adhesive	E 6
Thermally conductive adhesive	E 23-24
Thermally conductive foil both sides adhesive	E 7-8
Thermally conductive foil made of siliconelastomer	E 2-5
Thermal transfer compound and thermal interface film	E 20-22
U-Extruded heatsinks	A 123-124
Vibration dampers and solder terminals	E 41-43

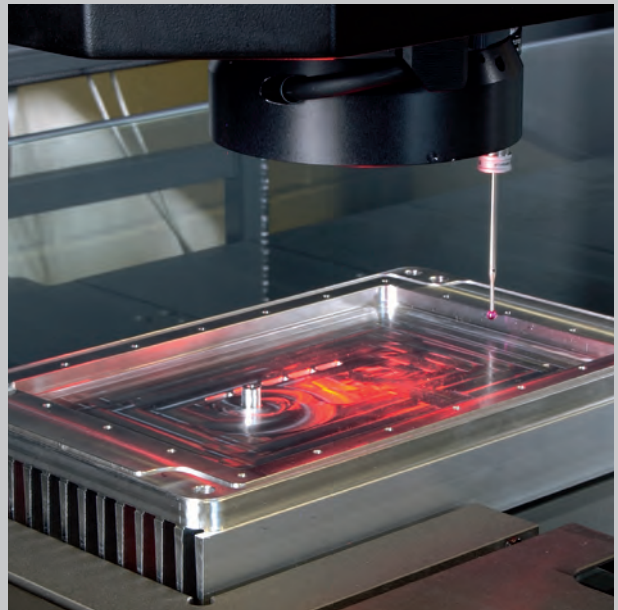

certified quality management



own tool-making department



foresighted storekeeping

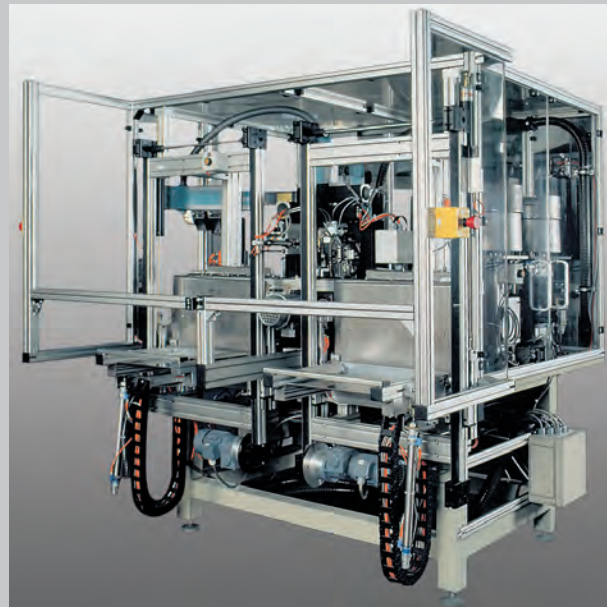

efficient special machines



precise punching department



up-to-date milling technology



foyer of the company



motivated employees



committed field service

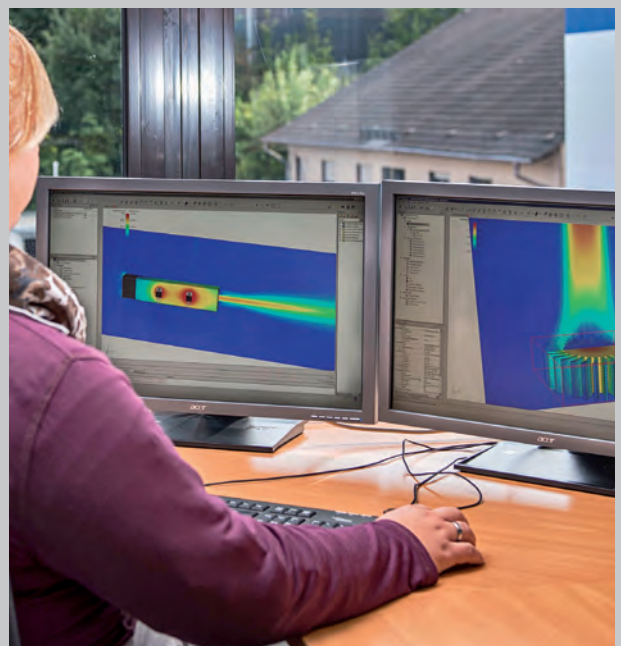
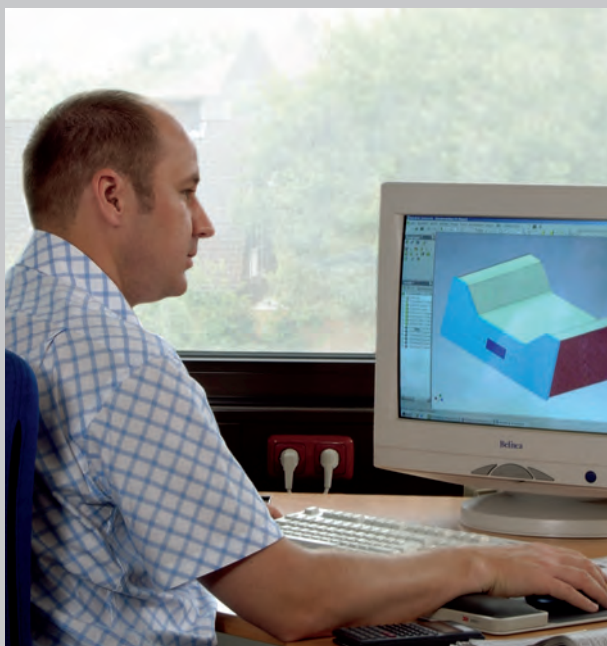

innovative product development

Quality-Management System DIN EN ISO 9001

We are certified to DIN EN ISO 9001.

This process-directed quality management system implies a constant focus on satisfying the demands of customers, and this is the major objective of our company.

The implementation and further development of our quality management system demonstrably ensures

- guaranteed customer satisfaction and thus the success of our company,
- compliance with customers' requirements at all times through defined processes,
- early detection and prevention of errors, and
- checking of both process effectiveness and efficiency on a regular basis together with steady improvement.

It is through constant vigilance and the provision of evidence that we deliver flawless products, which fully comply with quality requirements, that we maintain our quality certification.

In order to secure lasting company success and to meet our customers' expectations now and in the future, we define measurable objectives within the framework of our quality system, which are regularly checked and developed.

We are committed to constant measurement and improvement of our performance.

Our quality management system applies to all processes carried out by our company.

Certificate

Standard **ISO 9001:2008**

Certificate Registr. No. 09 100 4274

TÜV Rheinland Cert GmbH certifies:

Certificate Holder:

fischer elektronik 

Fischer Elektronik GmbH & Co. KG
Nottebohmstraße 28
D - 58511 Lüdenscheid

Scope:

Design/construction, manufacture, assembly and technical advice for heatsinks, sockets, connectors, mounting parts, cases, 19" assembly systems, computer accessories

An audit was performed, Report No. 4274. Proof has been furnished that the requirements according to ISO 9001:2008 are fulfilled.

The due date for all future audits is 31-10 (dd.mm).

Validity:

The certificate is valid from 2012-11-01 until 2015-10-31.
First certification 1994

2012-10-23

TÜV Rheinland Cert GmbH
Am Grauen Stein · 51105 Köln



DGA-ZM-58-95-00

www.tuv.com

 **TÜVRheinland®**
Precisely Right.

Certificate

Standard **ISO 14001:2004**

Certificate Registr. No. 01 104 8209

TÜV Rheinland Cert GmbH certifies:

Certificate Holder:

fischer elektronik 

Fischer Elektronik GmbH & Co. KG
Nottebohmstraße 28 · D - 58511 Lüdenscheid

Scope:

Design/construction, manufacture, assembly and technical advice for heatsinks, sockets, connectors, mounting parts, cases, 19" assembly systems, computer accessories

An audit was performed, Report No. 8209. Proof has been furnished that the requirements according to ISO 14001:2004 are fulfilled.

The due date for all future audits is 31-12 (dd.mm).

Validity:

The certificate is valid from 2014-01-01 until 2016-12-31.
First certification 1998

2013-10-22

Management
TÜV Rheinland Cert GmbH
Am Grauen Stein · 51105 Köln



www.tuv.com

 **TÜVRheinland®**
Precisely Right.

Environmental Management System DIN EN ISO 14001

Fischer Elektronik considers protection of the environment and saving of natural resources entrepreneurial tasks of high priority.

Aware of this, Fischer Elektronik was the first German heat-sink manufacturer to implement, in 1998, the environmental management system in accordance with DIN EN ISO 14001.

Our entrepreneurial responsibility comprises preventing accidents, safeguarding against occupational diseases, designing workplaces to suit human requirements, developing products which are safe to use, saving resources and avoiding environmental impact to the maximum extent possible.

We already consider environmental compatibility at the product and process development stage. The environmental impact of our activities is documented, assessed and in a continuous improvement process reduced to a minimum.

Implementation and consistent working on and with the environmental management system is a vital process and a constant challenge but finally it will always lead to better results.

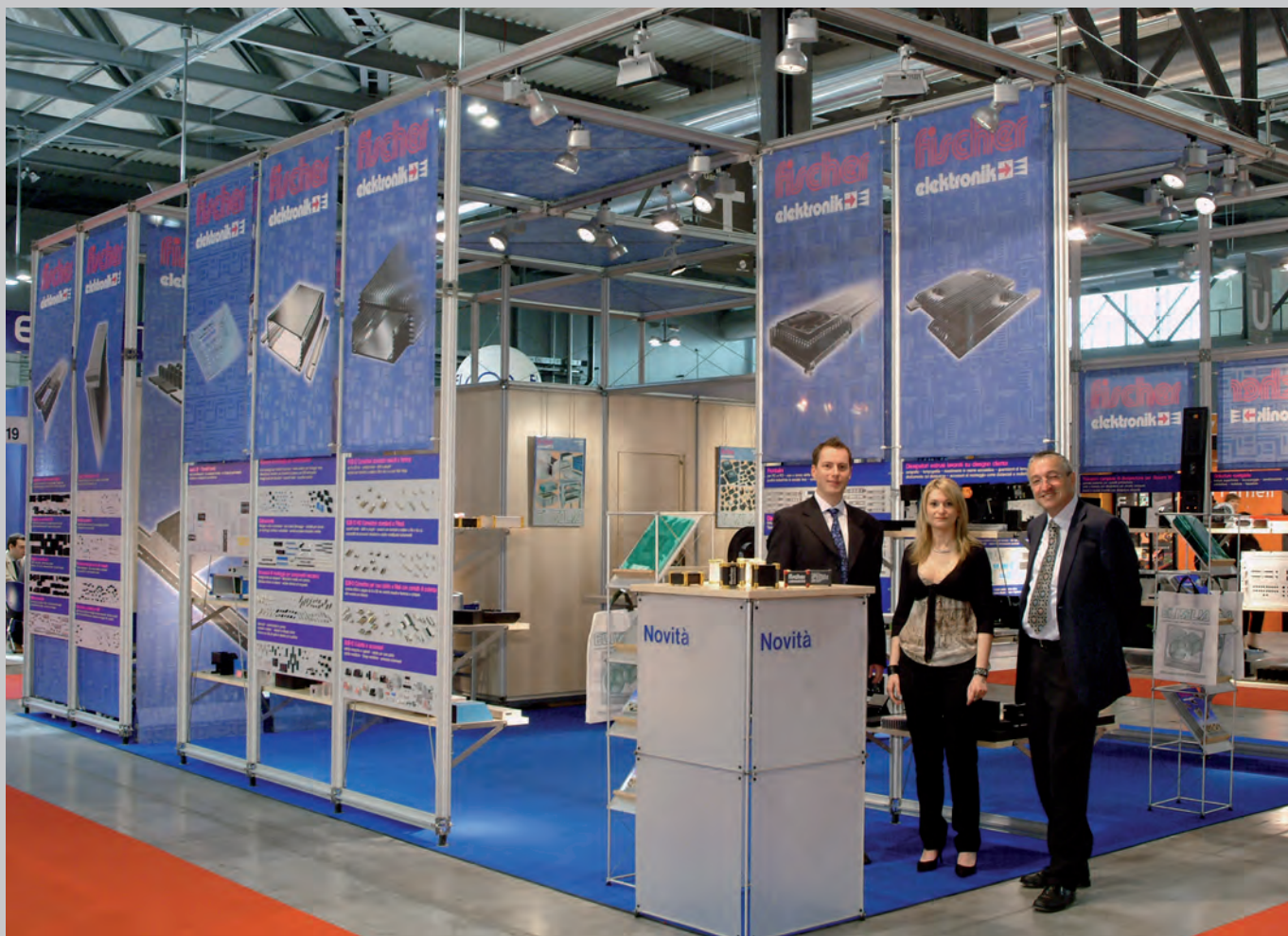

BIAS, Milan

I



Electronica, Tel Aviv

IL



PCIM, Nuremberg

D



Electro Salon, Budapest

HU



Elkom, Helsinki

FI



Paris **F**
 16. 9. - 18. 9. 2014
www.enova-event.com
 hall 7.2



WindEnergy
 Hamburg

Hamburg **D**
 23. 9. - 26. 9. 2014
www.windenergyhamburg.com
 hall B 7, stand 537



Bregenz **A**
 30. 9. - 2. 10. 2014
www.led-professional.com



Paris **F**
 14. 10. - 15. 10. 2014
www.forumled.com
 stand B 10



electronica

Munich **D**
 11. 11. - 14. 11. 2014
www.electronica.de
 hall B 1, stand 155



London **GB**
 19. 11. - 20. 11. 2014
www.luxlive.co.uk
 hall A 32



embedded world
 Exhibition & Conference

Nuremberg **D**
 24. 2. - 26. 2. 2015
www.embedded-world.de
 stand 4 A - 311



Nuremberg **D**
 20. 5. - 22. 5. 2015
www.pcim.de



S.E.E.
 SCANDINAVIAN
 ELECTRONICS
 EVENT

Stockholm **S**
 19. 4. - 21. 4. 2016
www.see-event.se

Explanations – references – printings

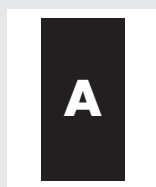

... index area:
shows topics/categories
"current"



Standard aluminium profiles	→	A 135 - 136
Technical explanations	→	A 2 - 8
Extruded heatsinks	→	A 22 - 83
Assignment table	→	A 18 - 22

SA = black anodised
MI = solderable surface
ME = clear anodised
TP = chrom-free transparent passivated

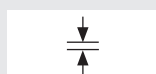

... index area:
shows topics/categories
"following"

... page number

... footnotes, give references to pages with combinable or similar products

... option for surface finishing

... link to page

... length on stock in mm

... hole pattern

... symbol of heatsink geometry

... thermal resistance in K/W

... thickness of sheet/plate

... air/speed in m/s

Imprinting of cardholders - Your and our time is expensive

An order for imprinting must state the font, the font size and the exact position of the imprint with dimensions, taking due account of countersunk holes etc.. When placing the first order, the company logo must be supplied as a vector file. If these conditions are not complied with, the order for imprinting may have to be turned down, or additional costs will have to be charged.

Compliance with the following criteria ensures smooth handling:

Adobe Illustrator (.ai/.eps) without half-tone images, fonts transformed into paths or supplied

CorelDraw (.cdr)

Adobe Acrobat (.pdf)

QuarkXPress (.qxd) all fonts enclosed; half-tone images colour-separated (full-tone or scale colours) and with correct resolution (300 dpi colour, black / white 600 dpi), no RGB

InDesign (.indd)

All this takes additional time and consequently incurs extra costs.

The usability must be checked by our printing shop:

screen formats (.jpg, .gif, .png) and paper copies, stickers and the like are not suitable for preparing printer's copies!

Copies that definitely cannot be used:

Imperfect copies such as fax copies / Microsoft Office files (.doc, .xls, .ppt) can only be used for information or for transmitting texts.

Please always add dimensional drawings (.dxf) to the parts to be imprinted! Please note as a general rule:

Retouching work extending beyond the standard time will be invoiced additionally at cost price.

No part of this catalogue may be reproduced or distributed without prior written consent of Fischer Elektronik. All data contained in this catalogue, in texts, illustrations, documents and descriptions are subject to copyright and the provisions of DIN ISO 16016. All rights reserved.

© Copyright Fischer Elektronik 1969 ... 2014

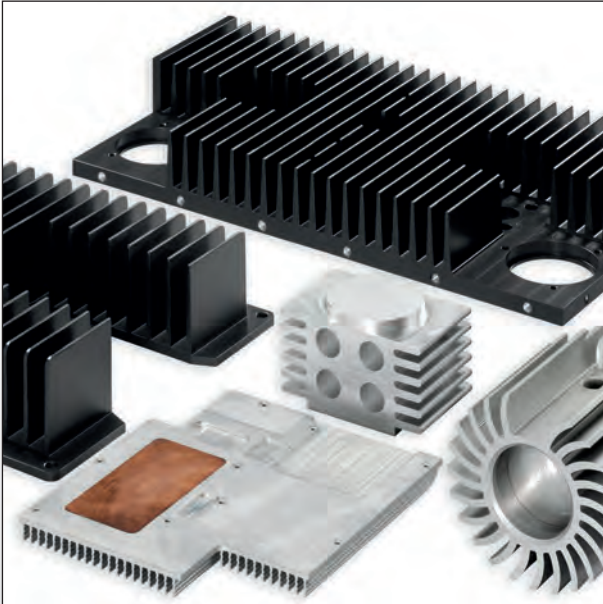

Machined heatsinks

- several hundreds of extrusion profiles available
- future orientated stockkeeping of heatsink profiles in a fully automatic honeycomb warehouse
- precise milling treatments in highest quality
- effective heat spreading by means of heatsinks with grouted copper areas
- designs and modifications according to your demand



Fluid heatsinks

- fluid heatsinks for dissipation of big heat flow volumes
- compact design with internal lamella structure
- thick bottom plates for optimal heat dissipation
- I- and U streamed versions
- water connection or mounting flange for your special application
- customized treatments and solutions

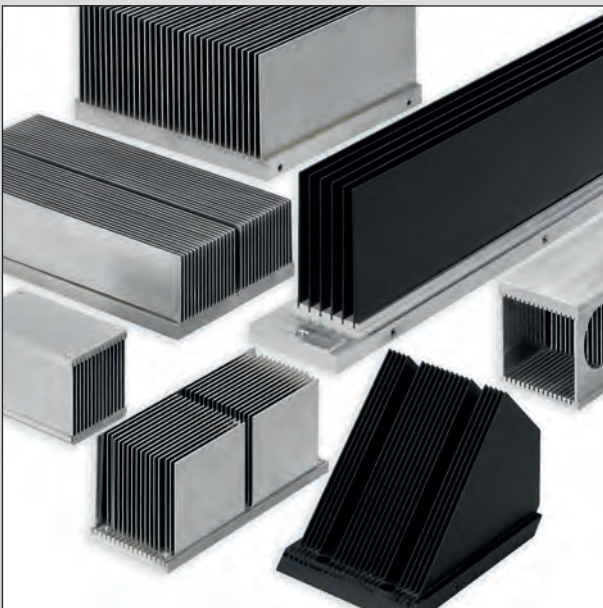

Lamella heatsinks

- compact lamella heatsinks with a big surface
- special design for forced convection
- thermotechnical optimal fitted lamellas
- precise milled flat semiconductor mounting surface
- single and double sided bottom plate made of aluminium or copper
- production according to customer specified demands



Extruded heatsinks with solder pins

- solid pressed in soldering pins and threaded bolts for a direct pcb-mounting
- for horizontal and vertical mounting position
- standard drilling patterns and transistor retaining springs for various semi-conductive elements
- soldering pins with insulation for spacing help
- variations and modifications according to drawing

1. General points

In order to provide optimum performance of semi-conducting devices it is essential not to exceed the maximum junction temperature indicated by the manufacturer.

Generally this maximum junction temperature can only be maintained without exceeding it by running the device concerned at lower power outputs.

At outputs approaching the maximum ratings semi-conductor devices have to be cooled by so called heatsinks, sometimes called dissipators.

The thermal performance of these heatsinks primarily depends on the thermal conductivity of the material from which they are made, size of surface area and mass.

In addition, surface colour, mounting position, temperature, ambient air velocity and mounting place all have varying influence on the final performance of the heatsink from one application to another..

However, a figure for thermal resistance can be experimentally determined in a reliable manner and used in the equations that follow in part 2.

There are no agreed international standard methods for testing electronic cooling systems or for the determination of the thermal resistance.

Therefore the diagrams and values given in our catalogue have been determined under practical operating conditions and therefore allow the most suitable heatsink from the range to be selected.

We expressly point out that all information and data is given to the best of our knowledge and belief. The user is solely responsible for the proper use of our products and he should check their suitability for the intended application.

Fischer Elektronik do not assume any warranty, whether expressed or implied, for the suitability, function or merchantability of their products in specific or general applications, and they cannot be held liable for accidental or consequential damage due to non-observance of the above.

Furthermore Fischer Elektronik reserve the right to carry out technical modifications to their products at any time. All orders are subject to the General Sales Conditions of Fischer Elektronik.

2. The determination of thermal resistance

The thermal resistance is the parameter that is the most important in cooler selection, apart from mechanical considerations.

For determination of the thermal resistance the following equation applies:

$$\text{Equation 1: } R_{thK} = \frac{\vartheta_i - \vartheta_u}{P} - (R_{thG} + R_{thM}) = \frac{\Delta\vartheta}{P} - R_{thGM}$$

In case of an application where the maximum junction temperature is not exceeded the temperature has to be verified. When the case temperature has been measured the use of the following equation will enable the maximum junction temperature to be calculated:

$$\text{Equation 2: } \vartheta_i = \vartheta_G + P \times R_{thG}$$

The meaning of the determinants:

ϑ_i = maximum junction temperature in °C of the device as indicated by manufacturer.
As a »safety factor« this should be reduced by 20-30 °C.

ϑ_u = ambient temperature in °C.
The rise in temperature caused by radiant heat of the heatsink should be increased by a margin of 10-30 °C.

$\Delta\vartheta$ = difference between maximum junction temperature and ambient temperature.

ϑ_G = measured temperature of device case (equation 2).

P = maximum power rating of device in watts

R_{th} = thermal resistance in K/W

R_{thG} = internal thermal resistance of semiconductor device (as indicated by manufacturer)

Heatsinks profile-overview	→ A 13 - 17	Heatsinks for SSR	→ A 11 - 12
Heatsink special design	→ A 137 - 138	Die-cast heatsinks	→ A 125
Special profiles	→ A 140	Assignment table	→ A 18 - 20
Heatsink as visual & decor-parts	→ A 10	Order example	→ A 21

R_{thM} = thermal resistance of mounting surface. For TO 3 cases the following approximate values apply:

1. dry, without insulator 0.05 - 0.20 K/W
2. with thermal compound/without insulator 0.005 - 0.10 K/W
3. Aluminium oxide wafer with thermal compound 0.20 - 0.60 K/W
4. Mica wafer (0.05 mm thick) with thermal compound 0.40 - 0.90 K/W

R_{thK} = thermal resistance of heatsink, which can be directly taken from the diagrams

R_{thGM} = sum of R_{thG} and R_{thM} . For parallel connections of several transistors the value R_{thGM} can be determined by the following equation:

$$\text{Equation 3: } \frac{1}{R_{thGM \text{ ges.}}} = \frac{1}{R_{thG1} + R_{thM1}} + \frac{1}{R_{thG2} + R_{thM2}} + \dots + \frac{1}{R_{thGn} + R_{thMn}}$$

The result can be substituted into equation 1.

K = Kelvin, which is the standard measure of temperature differences, measured in °C, therefore 1°C = 1 K.

K/W = Kelvin per watt, the unit of thermal resistance.

Calculation examples:

1. A TO 3 power transistor with 60 watt rating has a maximum junction temperature of 180 °C and an internal resistance of 0.6 K/W at an ambient of 40 °C with aluminium oxide wafers.

What thermal resistance is required for the heatsink?

given:

$$\begin{aligned} P &= 60 \text{ W} & R_{thG} &= 0.6 \text{ K/W} \\ \vartheta_i &= 180 \text{ °C} - 20 \text{ °C} = 160 \text{ °C (for safety margin)} & R_{thM} &= 0.4 \text{ K/W (average value)} \\ \vartheta_u &= 40 \text{ °C} \end{aligned}$$

find: R_{thK} using equation 1

$$R_{thK} = \frac{\vartheta_i - \vartheta_u}{P} - (R_{thG} + R_{thM}) = \frac{160 \text{ °C} - 40 \text{ °C}}{60 \text{ W}} - (0.6 \text{ K/W} + 0.4 \text{ K/W}) = \underline{1,0 \text{ K/W}}$$

2. Same conditions as above but for three devices with equally distributed power ratings.

solution use equation 1 and equation 3

$$\frac{1}{R_{thGM \text{ ges.}}} = \frac{1}{0.6 + 0.4 \text{ K/W}} + \frac{1}{0.6 + 0.4 \text{ K/W}} + \frac{1}{0.6 + 0.4 \text{ K/W}} = \frac{3}{1} \text{ W/K}$$

$$R_{thGM \text{ ges.}} = \frac{1}{3} \text{ K/W} = \underline{0.33 \text{ K/W}}$$

substitute into Equation 1 gives:

$$R_{thK} = \frac{160 \text{ °C} - 40 \text{ °C}}{60 \text{ W}} - 0.33 \text{ K/W} = \underline{1.67 \text{ K/W}}$$

With these values determined, the tabulation on page A 13 - 17 can be used to give a choice of possible heatsink profiles. Then by examination of the drawings and curves the final choice can be made.

3. A transistor with power rating of 50 W and internal thermal resistance of 0.5 K/W has a case temperature of 40 °C. What is the actual value of junction temperature?

given:

$$P = 50 \text{ W} \quad R_{thG} = 0.5 \text{ K/W} \quad \vartheta_G = 40 \text{ °C}$$

find: ϑ_i using equation 2

$$\vartheta_i = \vartheta_G + (P \cdot R_{thG}) \quad \vartheta_i = 40 \text{ °C} + (50 \text{ W} \cdot 0.5 \text{ K/W}) = \underline{65 \text{ °C}}$$

Thermal resistances of any profiles with forced convection

$$\begin{aligned} R_{thKf} &\approx \alpha \cdot R_{thK} \\ R_{thKf} &= \text{thermal resistance with forced convection} \\ R_{thK} &= \text{thermal resistance with natural convection} \\ \alpha &= \text{factor of proportion} \end{aligned}$$

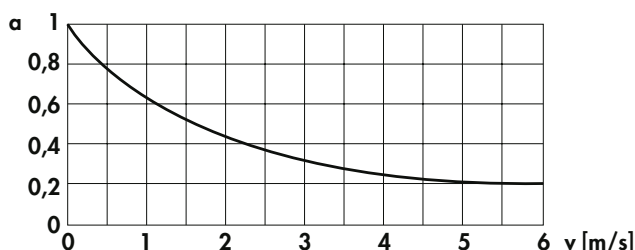

Computer based thermal simulation for optimal cooling concepts

Performance, service life and reliability of electronic semiconductor devices are significantly determined by the thermal load to which the devices are exposed. An exceeding of the maximum operating temperature leads to malfunctions. An exceeding of the permissible junction temperature leads to a destruction of the semiconductor. To make it worse there is an advancing trend in the semiconductor industry for continuous increasing integration- and power densities of electronic devices. For the solution of thermal problems the first question is which kind of heat dissipation has to be considered. For this there are different processes available: by means of free convection (passive) with different heatsink solutions, by means of forced convection (active with help of fans, cooling aggregates) or by means of fluid media (fluid cooling).

However, electronic devices and systems have many different boundary and installation conditions. Therefore the choice of the optimum thermal management is often difficult. There are surely possibilities to find the right heat dissipation concept by using the thermal resistance for calculations or by testing and verifying prototypes directly in the application, but nowadays customer specified mechanical adjustments are requested and demanded more than ever. Small mechanical post-machinings, such as additional integrated threads or drilling can be considered in the calculation with safety reserves in the temperature of the thermal resistance, but extensive modifications demand a repeated inspection of the thermal circumstances.

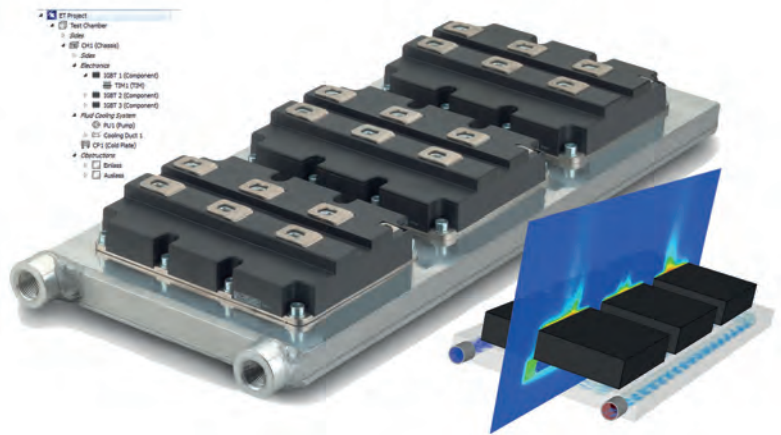

To facilitate the determination of passive heat dissipation concepts Fischer Elektronik offers a computer based thermal simulation as a kind of service.

Considered factors in the thermal simulation

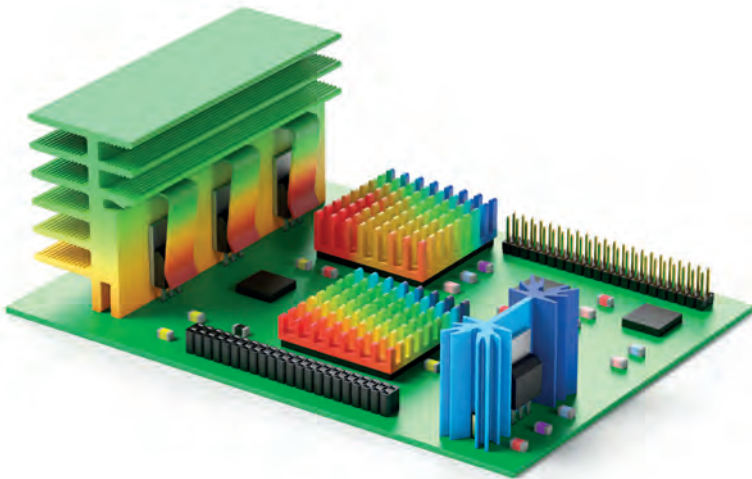

With help of the computer based thermal simulation the necessary characteristics of the cooling concept can be determined exactly. Based on physical concepts such as mass, energy and impulse the software especially considers the thermal requirements for free or forced convection. Simultaneously the system is aligned to thermal dissipation by means of fluid. Moreover the thermal simulation calculates physical effects such as thermal radiation and turbulences. The emission factor of the different surfaces also plays its role. As a result the simulation software delivers a precise cooling solution for the application and is a big help for the decision-making and interpretation of the electronic design.

Advantages of a computer based simulation

The computer based thermal simulation is already used for the prototype development. Herewith the development cycles of heat dissipation concepts is reduced considerably. Unsuitable concepts can be discarded quickly and without big costs of material. A lot of features and options of the simulation system also reduce the temporary and apparatuses efforts compared to a conventional simulation in the measurement chamber.

We will be happy to advise you in detail about the theme thermal simulation.

Heatsinks profile-overview	→ A 13 - 17
Heatsink special design	→ A 137 - 138
Special profiles	→ A 140
Heatsink as visual & decor-parts	→ A 10

Heatsinks for SSR	→ A 11 - 12
Die-cast heatsinks	→ A 125
Assignment table	→ A 18 - 20
Order example	→ A 21

Remarks:

1. The values indicated in the diagrams apply only for heatsinks with black anodised surface, mounted vertically and natural convection.

Correction factors: natural surface: +10 to 15 % for horizontal mounting: +15 to 20 %

2. Heatsink profiles are extruded to European standard DIN EN 12020 (former DIN 17615).

For profiles exceeding a circumscribed circle of 350 mm, the tolerances to DIN EN 755 (former DIN 1748) apply.



Important note:

Manufacturers of certain electronic components, especially modules with a large surface area, IGBT etc., specify installation surfaces for heatsinks etc. with an flatness, which is beyond standard tolerances. Such perfect flatness can only be achieved by milling the installation surface. Furthermore, it should be noted that threaded wire inserts may be required in order to reach higher tightening torques in aluminium (e.g. Heli-Coil or similar.). Please observe the semiconductor manufacturers' information.

3. The mentioned heatsink profiles in our catalogue contain so called extrusion marks between the fins for a profile identification. To avoid misuse the operator has to check the size and position for the mechanical treatment or placement of the components.

4. Profile extruded threaded channels are no threads conforming to standards, as they have no thread pitch. The thread pitch is imitated by staggered webs (ribs). The customer is responsible for appropriate use.

5. Machining of our extruded and non extruded profiles conforms to requirements of DIN ISO 2768 m - unless otherwise stated. For all ICK S types DIN ISO 2768c is valid.

6. The lengths of extruded profiles [] and the pin layouts [] indicate only the standard range. We offer every profile cut to customer's exact length and machining requirement made to drawing or sample. We bore, countersink, mill, saw, grind and cut threads into your heat sink to meet your specific requirements. With our modern machine tools including CNC machining centres, multispindled drills (up to 26 drillings/threads at the same time) and digital milling and stamping tools plus our own "in house" tool room we are able to manufacture competitively priced prototypes as well as batch and mass produced parts with short lead times.

7. The standard material of our heatsinks is warm age-hardened aluminium alloy according to EN AW 6060 – T66 (former AlMgSi05 – F22 acc. to DIN 1748). Our standard surface treatments are raw degreased aluminium (Al) and black anodised (SA). On request, we anodise clear natural (ME) or decorative in any colour that is technically possible.

8. If you cannot find a suitable profile within our range of approx. 400 profiles, 13 small heatsinks and 50 finger shaped heatsinks, we can design and produce to your requirements. Please contact us at the start of your next project so that we can work together, either directly or through our representatives. Remember that we have the ability to find the solution for "your" cooling problem.

9. Note on tolerances

All dimensions given in this catalogue for products, items and machined parts are acc. to DIN ISO 2768 m if not otherwise stated. Not included are items like extruded profiles, diecasts, handles, vibration dumpers etc. for which different standards apply.

Update - August 2014

The information given in this catalogue were established and examined carefully.

Nevertheless, mistakes or printing errors, and especially technical modifications and updating and improvement of our products, cannot be excluded. All trade marks are recognised even if they are not specifically identified or mentioned. No identification does not imply that a product or trademark is not registered. No part of this catalogue may be reproduced or distributed without prior written consent of Fischer Elektronik. All data contained in this catalogue, in texts, illustrations, documents and descriptions are subject to copyright and the provisions of DIN ISO 16016. All rights reserved.

© Copyright Fischer Elektronik 1969 ... 2014

General information

Blind holes are produced after anodising. Through holes are produced before anodising. With completely visual parts, additional painting is recommended. The sections are extruded according to DIN EN 12020. For sections that exceed a circumscribed circle of 300 mm, DIN EN 755 apply. The machining tolerances are specified according to DIN ISO 2768 m.

Visual parts: Please indicate at which place **clamp points** are allowed! We recommend e.g. supplementary laquering.

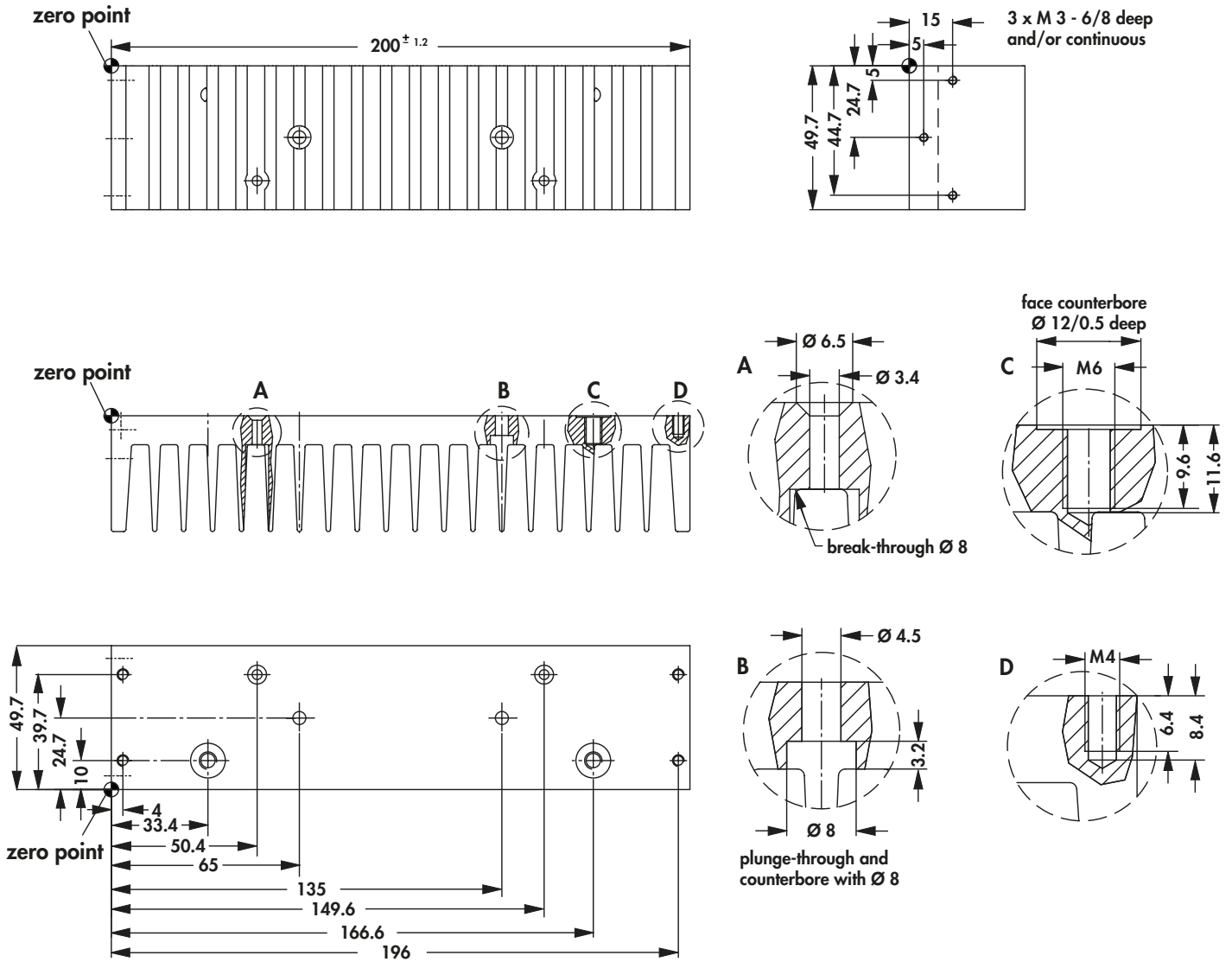

Heatsinks profile-overview → A 13 - 17
 Heatsink special design → A 137 - 138
 Special profiles → A 140
 Heatsink as visual & decor-parts → A 10

Heatsinks for SSR → A 11 - 12
 Die-cast heatsinks → A 125
 Assignment table → A 18 - 20
 Order example → A 21

A 6

Information for dimensioning, shown on SK 47 general:

The deflection can be up to 0.8 mm concave, 0.2 mm convex. If a certain flatness of the bottom surface is required the bottom thickness can be decreased by a maximum of approx. 0.8 mm by means of face-milling. This situation must be taken into consideration with the bore hole depths for blind holes.

Counterbores and bore hole diameters are to be produced according to DIN 74, if not explicitly stated otherwise. The depth of thread should be calculated as follows.

Example M 5:

thread: $\langle M \rangle 5 \times 1.6 \text{ mm} = 8 \text{ mm}$

core bore: $8 \text{ mm} + 2 \text{ mm} = 10 \text{ mm}$

Examples:

cutout A: Through-hole according to DIN 74 A m 3, counterbore bottom side, undercut of the fins.

cutout B: Through hole with break-through of the fins according to DIN 74 H m 4, counterbore on fin side.

cutout C: Thread M 6. Depth of thread $1.6 \times 6 \text{ mm} = 9.6 \text{ mm}$, bore depth $9.6 \text{ mm} + 2 \text{ mm} = 11.6 \text{ mm}$.

Bore hole on fin base is plunged through. Face counterbore dia. 12×0.5 on bottom side.

cutout D: Blind thread M 4. Depth of thread $1.6 \times 4 \text{ mm} = 6.4 \text{ mm}$, bore depth $6.4 \text{ mm} + 2 \text{ mm} = 8.4 \text{ mm}$.

Extrusion tolerances – production tolerances

There is often the problem, that the production tolerances cannot be adhered to, due to the extrusion tolerances. The two examples show how the production tolerances can be cut in half by means of suitable dimensioning (here: extension of the zero point from the outer edge to the center of the section).

When taking unfavourable extrusion tolerances into consideration a difference of 1.1 mm arises between the two types of dimensioning with respect to the axis of symmetry.

SK 82

extrusion tolerance $\pm 3.5 \text{ mm}$

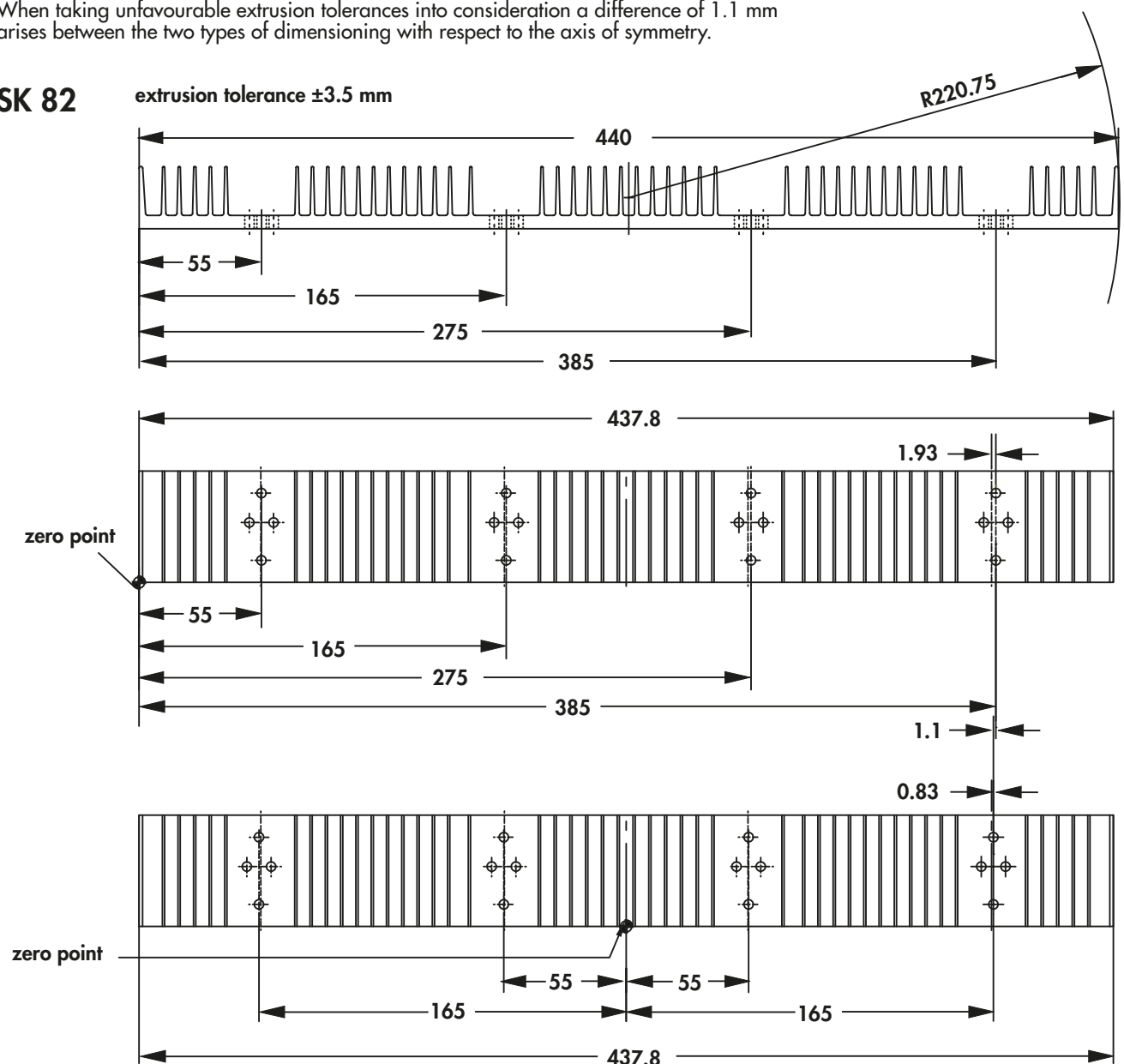

SK 34

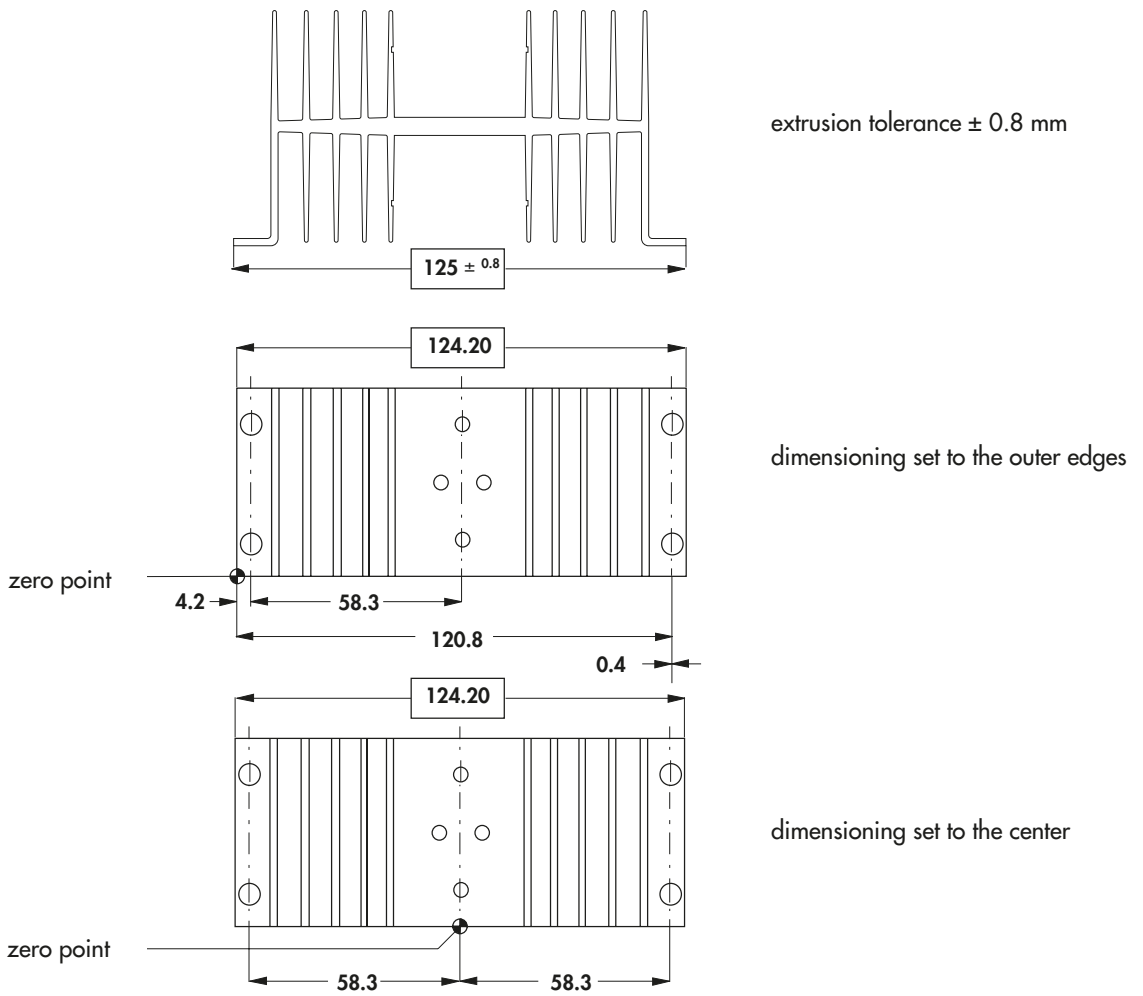

When taking unfavourable extrusion tolerances into consideration, a difference of 0.4 mm arises between the two types of dimensioning with respect to the axis of symmetry.

Milling

If, when milling heatsinks, cooling aggregates, etc., the milling tool diameter is smaller than the area being milled for production reasons, so called „milling grooves“ with steps or edges are produced (see sketch). Even if the roughness depth value for the surface is observed, it is a good idea to specify the area of the component in which no milling edges are allowed.

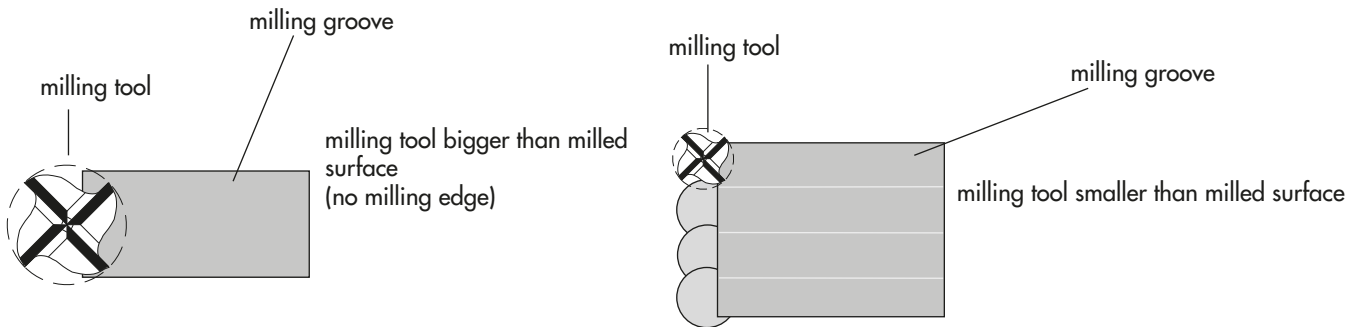

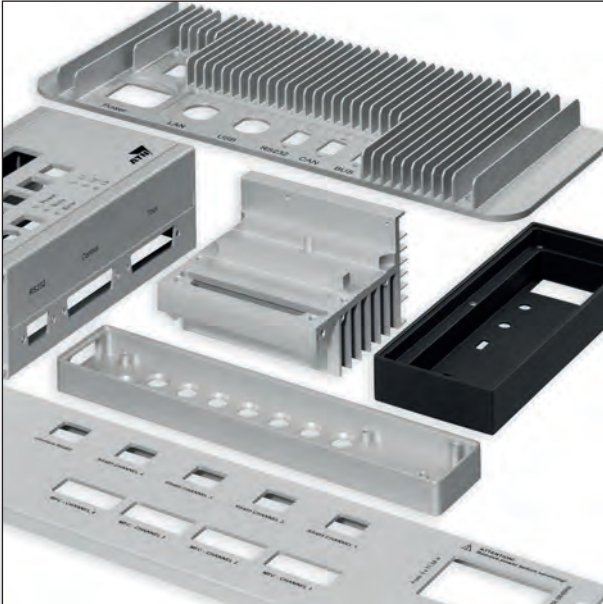

Decorative aluminium milled parts

- high quality, very precise milled, decorative aluminium parts
- exact radii and sharp-edged cutouts
- precision ground surfaces
- natural colour and black anodized

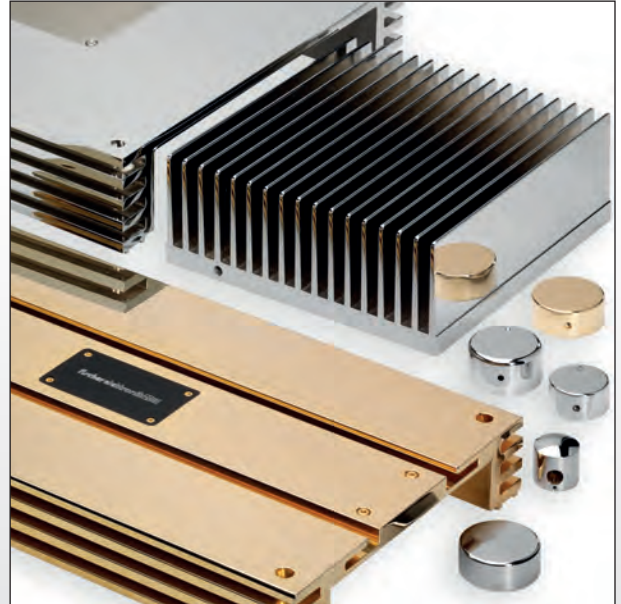

Chromium plating and gold plating

- chromium plating and gold plating of front panels, extruded profiles and construction parts
- qualitative constant and reproducible, high quality surfaces
- various gloss levels by means of different polishing processes
- processing of brass, aluminium and steel



Surface refinements

- corrosion resistant and decorative anodize layers
- lacquerings and durable powder coatings in all current RAL colours
- anti-glare surfaces, Nextel®-Suide Coating
- electrically conductive surfaces, chromate VI free
- prevention of clamp marks by means of special contacting systems



Development and construction

- competent partner with experience of more than 40 year
- Innovative product development, product-specific support by means of application engineers
- design assistance, feasibility analyses and product optimizations
- construction support and preparation of drawings

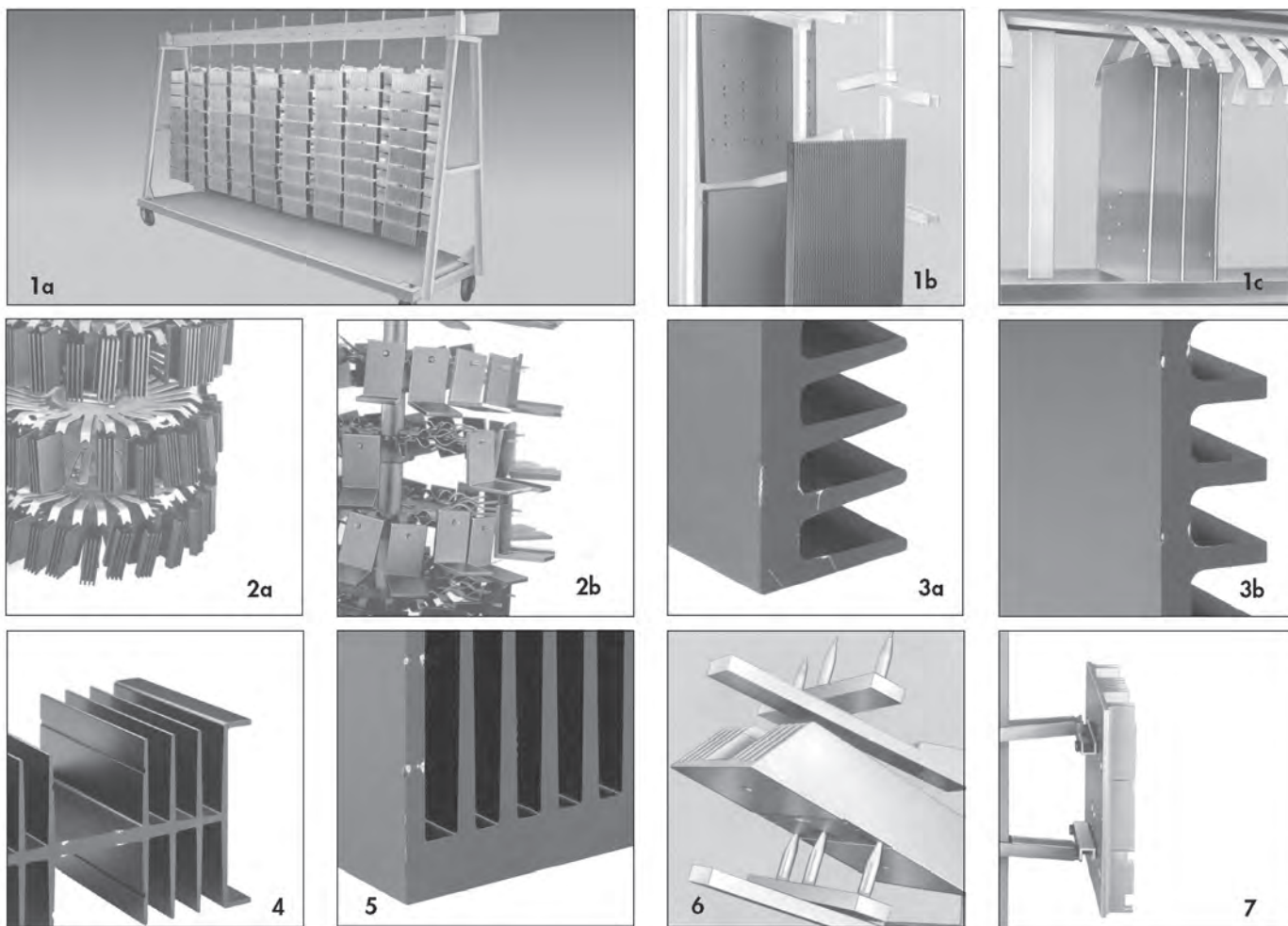

Anodising (also known as ELOXAL: **E**lectrically **O**Xidised **A**luminium) is used in many cases for decorative surface protection of aluminium. In this process, the aluminium parts to be treated are connected to the positive pole of a direct-current source (anode) in a suitable electrolyte where aluminium, in so doing, forms the negative pole (cathode). The flowing direct current now causes a migration of oxygen-containing ions, with electrically negative charge, to the anode in order to deposit the oxygen. At this point, the aluminium reacts with this oxygen, forming aluminium oxide. A non-porous, electrically insulating, abrasion free, oxide barrier, or „eloxallayer“, then develops. The development and therefore thickness of this layer can be controlled by the amount of current flow.

For process handling, secure transportation and electrical connection, the parts to be anodised must be placed on „racks“ (figure 1). As excellent electrical contact is necessary and the parts being processed must be mounted on the carrying racks in a totally secure manner a high clamping force is required especially for those large and heavy heatsinks (figure 2). This will mean that „clamp marks“ are visible. These are mere bare points in the case of small and light weight heatsinks with black anodising (figure 3) but for heavy parts the clamping pressures and current can cause deformation of the surface (figure 4). Any such deformations on large heatsinks is unavoidable and varies with each part (figure 5).

If heat sinks are used as visual parts, in other words parts whose surface must be blemish-free in appearance, it is suggested that the customer will define specific areas which should have no clamp marks. If, for technical production reasons, it is not possible to place clamps on the remaining points then consideration should be either given to the construction of separate specialpurpose frames which will allow processing (figure 6). Existing or additional threaded holes may possibly also be used for screwing on fixing angles, upon which the clamps may then be placed (figure 7). Furthermore, there is always the possibility to remove the clamp marks by hand finishing, although some slight indentation may still be visible. Alternatively, instead of using the anodising process there are various paint finishes available.

With visual parts and mouldings, both discussion of all technical details and determination of the desired design in cooperation with the manufacturer - even at the initial enquiry stage - are imperative for the smooth completion of orders to the satisfaction of the customer.

Our experts are at your disposal for all technical advice.

Standard aluminium profiles
 Technical introduction
 Extruded heatsinks
 Assignment table

→ A 135 - 136
 → A 2 - 8
 → A 22 - 83
 → A 18 - 20

Drilling pattern for SSR
 Die-cast heatsinks
 High capacity heatsinks
 Heatsinks for PCB

→ A 12
 → A 125
 → D 30 - 32
 → A 89 - 112

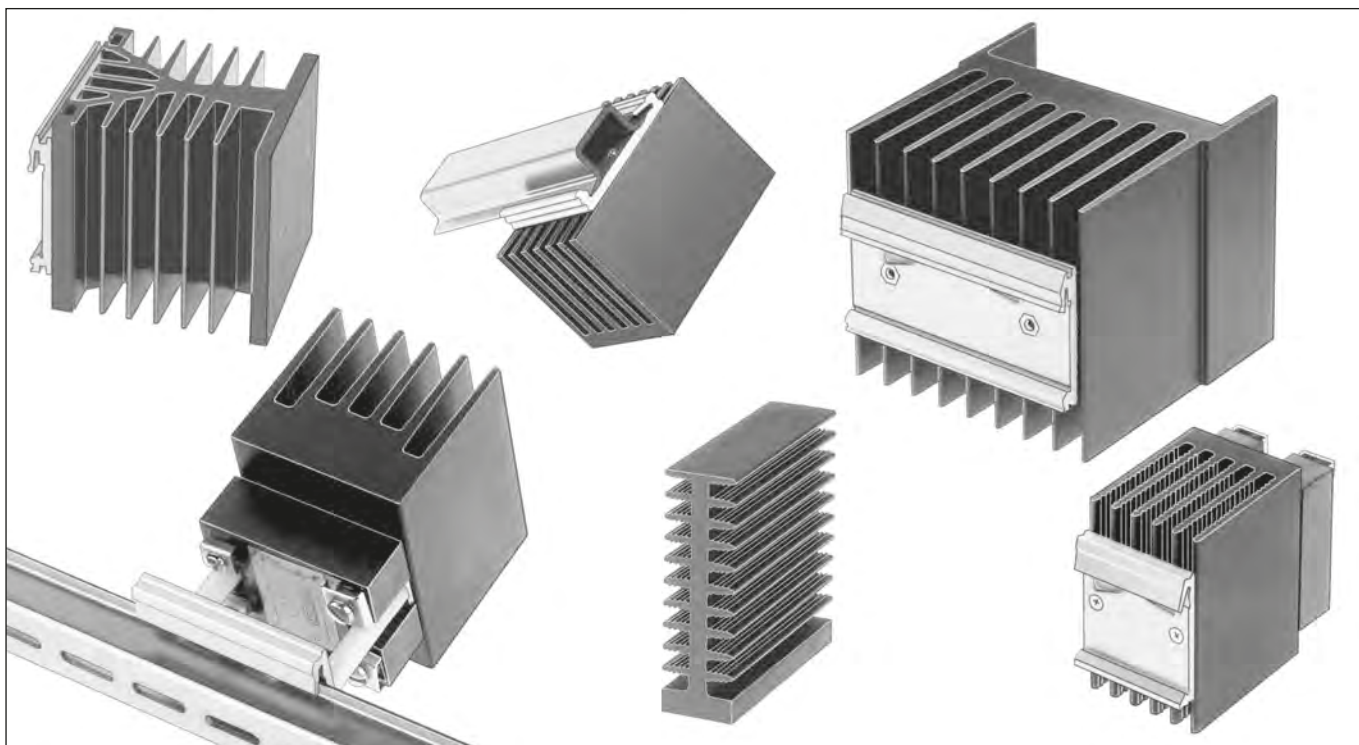

- universal clip fastening, suitable for all 35 mm mounting rails according to DIN EN 50 022, rail thickness from 1 to 2.3 mm → E 25
- fast and simple assembly of heatsinks by means of snapping them onto the mounting rail
- secure hold due to a stable extruded profile with integral stainless steel spring
- special lengths (≥ 40 mm) and drillings on request

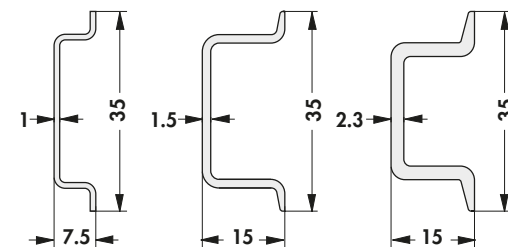
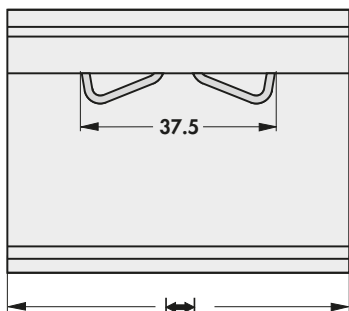
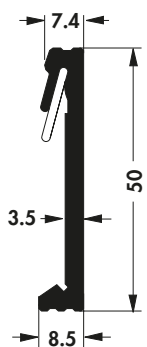

Examples of mounting rail versions suitable for KL 35

surface:

finish clear anodised

Heatsinks for solid state relays

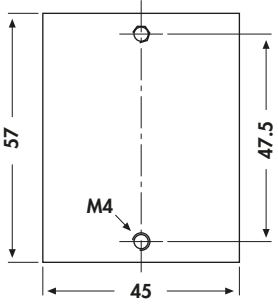
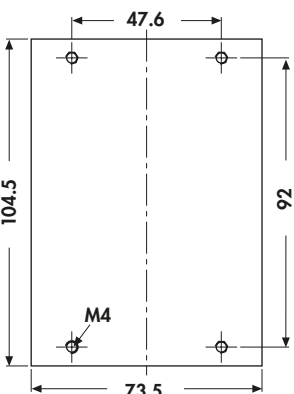
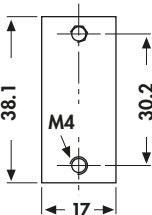
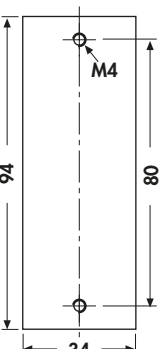
<p>perforations</p> <p>– drilling pattern rotated by 90° as well as further drilling patterns upon request</p>	<p>with KL 35</p> <p>– fixing of the SSR by means of screws with the help of insert nuts in the heatsink</p>		<p>without KL 35</p> <p>– fixing of the SSR by means of screws with the help of tapped holes in the heatsink</p>
	<p>art. no.</p>	<p>art. no.</p>	<p>art. no.</p>
<p>SSR 1</p> 	<p>SK 172 75 KL SSR 1</p>	<p>SK 89 75 KL SSR 1 SK 89 100 KL SSR 1 SK 111 75 KL SSR 1 SK 434 75 KL SRR 1 SK 453 75 KL SRR 1 SK 467 75 KL SRR 1 SK 507 75 KL SSR 1</p>	<p>SK 04 75 SSR 1 SK 33 75 SSR 1 SK 453 75 SSR 1 SK 455 75 SSR 1 SK 467 75 SRR 1 SK 507 75 SRR 1</p>
<p>SSR 2</p> 		<p>SK 89 100 KL SSR 2 SK 89 150 KL SSR 2 SK 176 100 KL SSR 2 SK 176 150 KL SSR 2 SK 194 75 KL SSR 2 SK 507 100 KL SSR 2</p>	<p>SK 04 150 SSR 2 SK 33 75 SSR 2 SK 507 100 SSR 2 SK 507 150 SSR 2</p>
<p>SSR 3</p> 	<p>SK 187 75 KL SSR 3</p>	<p>SK 111 75 KL SSR 3</p>	<p>SK 48 50 SSR 3</p>
<p>SSR 4</p> 	<p>SK 172 150 KL SSR 4</p>	<p>SK 455 100 KL SSR 4</p>	<p>SK 455 100 SSR 4 SK 467 100 SSR 4</p>

Distance sleeves → E 32 - 39
Fastening for mounting rail → E 25
Guide rails for PCBs → E 26 - 30
Mounting material for semiconductor → E 44 - 48

Spacers → E 40
Mica wafers → E 19
Aluminium oxide wafers → E 17 - 18
Mounting parts for heatsinks → A 2 - 8

Heatsink-chart

SK 440 D 30	SK 441 D 30	SK 458 D 30	SK 461 D 30	SK 497 D 30	SK 498 D 30
SK 47 A 49	SK 49 A 51	SK 56 A 54	SK 66 A 55	SK 90 A 48	SK 91 A 52
SK 93 A 56	SK 101 A 54	SK 102 A 50	SK 130 A 56	SK 139 A 53	
SK 149 A 53	SK 154 A 46	SK 155 A 45	SK 157 A 54	SK 158 A 58	
SK 159 A 58	SK 160 A 58	SK 161 A 58	SK 162 A 58		
SK 168 A 50	SK 190 A 52	SK 191 A 56	SK 193 A 50		
SK 198 A 53	SK 199 A 51	SK 416 A 47	SK 418 A 58	SK 438 A 52	
SK 439 A 55	SK 446 A 53	SK 466 A 43	SK 479 A 55		
SK 501 A 54	SK 502 A 49	SK 507 A 40	SK 510 A 46	SK 520 A 50	SK 523 A 55
SK 524 A 52	SK 530 A 57	SK 531 A 57	SK 533 A 57		
SK 535 A 57	SK 536 A 57	SK 537 A 57	SK 538 A 57		

Heatsink-chart classified in categories of thermal resistance at 75 mm length

Heatsink-chart

SK 539 A 57		SK 540 A 57		SK 553 A 44	SK 555 A 51	SK 557 A 50	
SK 568 A 54		SK 579 A 55		SK 580 A 51	SK 588 A 45	SK 591 A 49	
SK 601 A 44	SK 613 A 43	SK 614 A 52		SK 621 A 56		SK 57 A 64	
SK 30 A 67	SK 53 A 74	SK 82 A 75		SK 86 A 75		SK 15 A 77	
SK 163 A 78	SK 556 A 77	SK 83 A 79	SK 108 A 80	SK 109 A 80	SK 110 A 80	SK 435 A 81	
SK 144 A 82	SK 584 B 44	SK 590 B 46	SK 592 B 45	SK 615 B 45	SK 33 A 42	SK 42 A 49	
SK 58 A 45	SK 85 A 46	SK 92 A 41	SK 94 A 49	SK 113 A 48		SK 118 A 51	
SK 119 A 47	SK 120 A 45	SK 121 A 42	SK 132 A 44	SK 133 A 44	SK 135 A 39	SK 136 A 48	
SK 411 A 42	SK 412 A 47		SK 413 A 43	SK 429 A 37	SK 463 A 43		
SK 467 A 33	SK 503 A 46		SK 504 A 45		SK 519 A 48	SK 583 A 53	
SK 595 A 43	SK 71 A 64	SK 98 A 65	SK 197 A 65		SK 404 A 65		
SK 02 A 66	SK 34 A 67	SK 67 A 69	SK 148 A 68	SK 88 A 73	SK 80 A 74		
SK 147 A 74		SK 147 A 74		SK 147 A 74		SK 147 A 74	

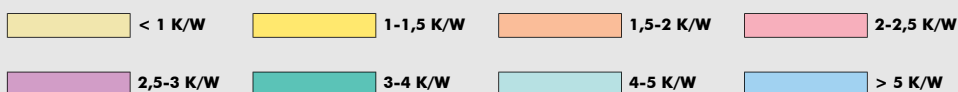

Heatsink-chart

SK 89 A 77	SK 140 A 77	SK 06 A 79	SK 23 A 79	SK 194 A 81	SK 40 A 82	SK 61 A 82	SK 415 A 90	SK 569 B 43								
SK 570 B 44	SK 571 B 44	SK 572 B 44	SK 577 B 43	SK 578 B 43	SK 599 B 45	SK 602 B 43	SK 50 A 37	SK 100 A 38								
SK 166 A 48	SK 408 A 40	SK 410 A 44	SK 417 A 46	SK 421 A 47	SK 433 A 41	SK 442 A 42	SK 453 A 33	SK 455 A 33	SK 464 A 39	SK 527 A 35						
SK 04 A 64	SK 72 A 63	SK 401 A 63	SK 403 A 64	SK 14 A 67	SK 39 A 67	SK 20 A 68	SK 84 A 68	SK 184 A 68	SK 74 A 71	SK 124 A 71	SK 195 A 71	SK 500 A 72	SK 08 A 73	SK 60 A 74		
SK 176 A 78	SK 172 A 81	SK 432 A 82	SK 46 B 43	SK 598 B 42	SK 407 A 39	SK 436 A 37	SK 450 A 34	SK 505 A 41	SK 508 A 41	SK 612 A 39	SK 73 A 64	SK 97 A 62	SK 03 A 66	SK 419 A 70		
SK 16 A 72	SK 79 A 73	SK 187 A 76	SK 11 A 79	SK 111 A 81	SK 44 A 90	SK 81 A 41	SK 189 A 32	SK 405 A 47	SK 406 A 38	SK 434 A 35	SK 445 A 34	SK 05 A 62	SK 18 A 62	SK 25 A 61		
SK 28 A 63	SK 63 A 62	SK 402 A 62	SK 01 A 66	SK 64 A 70	SK 48 A 73	SK 52 A 74	SK 32 A 76	SK 176 A 78	SK 172 A 81	SK 432 A 82	SK 46 B 43	SK 598 B 42	SK 407 A 39	SK 436 A 37	SK 450 A 34	SK 505 A 41

Heatsink-chart classified in categories of thermal resistance at 75 mm length

Heatsink-chart

SK 544 A 76	SK 596 A 76	SK 175 A 83	SK 105 A 90	SK 484 A 110	SK 487 A 87	SK 499 A 87	SK 514 A 86	
SK 593 A 87	SK 617 A 88	SK 99 A 37	SK 106 A 31	SK 134 A 28	SK 182 A 40	SK 424 A 34	SK 425 A 34	SK 426 A 36
SK 475 A 35	SK 545 A 39	SK 546 A 40	SK 567 A 35	SK 594 A 38	SK 19 A 63			
SK 45 A 63	SK 51 A 61	SK 165 A 61	SK 181 A 60	SK 36 A 66	SK 21 A 70	SK 65 A 70		
SK 69 A 71	SK 07 A 72	SK 55 A 83	SK 68 A 89	SK 112 A 89	SK 128 A 91	SK 414 A 90		
SK 481 A 85	SK 482 A 86	SK 483 A 87	SK 489 A 85	SK 495 A 87	SK 517 A 93	SK 518 A 93	SK 585 ... B 42	SK 589 A 86
SK 610 A 92	SK 618 B 42	SK 619 B 42	SK 620 B 42	SK 156 A 36	SK 174 A 30	SK 179 A 30	SK 180 A 36	SK 422 A 32
SK 444 A 38	SK 468 A 36	SK 472 A 31	SK 485 A 38	SK 566 A 26	SK 78 A 61	SK 107 A 60	SK 122 A 60	SK 150 A 61
SK 173 A 59	SK 185 A 73	LA LED 68 B 50	SK 96 A 91	SK 138 A 91	SK 451 A 91	SK 490 A 84	SK 573 A 85	SK 574 A 86
SK 576 A 85	SK 611 A 92	SK LED 2 B 48	SK LED 3 B 48	SK 177 A 27	SK 178 A 28	SK 400 A 28	SK 420 A 31	SK 423 A 32
SK 427 A 36	SK 437 A 24	SK 447 A 26	SK 448 A 27	SK 452 A 27	SK 454 A 24	SK 456 A 30	SK 469 A 23	

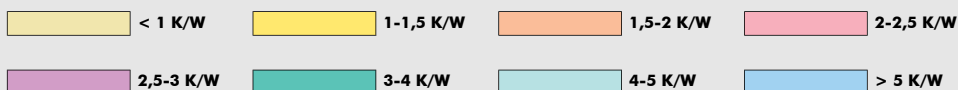





Heatsink-chart

B	SK 470 A 22	SK 471 A 29	SK 473 A 25	SK 476 A 24	SK 477 A 24	SK 478 A 23	SK 486 A 25	SK 493 A 28	SK 496 A 22
C	SK 509 A 29	SK 511 A 32	SK 513 A 31	SK 521 A 24	SK 522 A 23	SK 547 A 31	SK 548 A 34	SK 549 A 29	SK 550 A 27
D	SK 551 A 25	SK 552 A 23	SK 554 A 26	SK 558 A 23	SK 559 A 25	SK 560 A 26	SK 561 A 26	SK 562 A 29	SK 563 A 30
E	SK 564 A 30	SK 565 A 22	SK 581 A 28	SK 582 A 25	SK 586 A 22	SK 587 A 29	SK 597 A 27	SK 616 A 22	SK 09 A 59
F	SK 59 A 60	SK 145 A 59	SK 443 A 59	SK 31 A 72	SK 153 A 83	SK 494 A 83	ICK ... B B 52	ICK ... H B 52	ICK ... L B 52
G	SFP A 135	SK 12 A 123	SK 13 A 123	SK 75 A 105	SK 76 A 105	SK 95 A 108	SK 115 A 123	SK 125 A 91	SK 126 A 107
H	SK 431 ... A 124	SK 480 A 84	SK 492 A 84	SK 512 A 84	SK 515 A 94	SK 515 05 A 94	SK 516 A 94	SK 575 A 84	SK 609 A 92
I	SK LED 1 B 48	STP A 136	SU A 135	SVP A 136	SWP A 135	UK 14 SA ... A 123			

Heatsink-chart classified in categories of thermal resistance at 75 mm length







Assignment table of transistor heatsinks

	TO 3 	TO 66 	SOT 9 	TO 220 	SOT 32 
extruded profiles	SK 01	SK 01	SK 01	SK 09	SK 01
	SK 02	SK 02	SK 02	SK 59	SK 02
	SK 03	SK 03	SK 03	SK 145	SK 03
	SK 04	SK 04	SK 04		SK 04
	SK 05	SK 05	SK 05		SK 05
	SK 07	SK 07	SK 07		SK 07
	SK 08	SK 08	SK 08		SK 08
	SK 14	SK 14	SK 14		SK 14
	SK 16	SK 16	SK 16		SK 16
	SK 18	SK 18	SK 18		SK 18
	SK 19	SK 19	SK 19		SK 19
	SK 20	SK 20	SK 20		SK 20
	SK 21	SK 21	SK 21		SK 21
	SK 28	SK 28	SK 28		SK 28
	SK 30	SK 30	SK 30		SK 30
	SK 31	SK 31	SK 31		SK 31
	SK 34	SK 34	SK 34		SK 34
	SK 36	SK 36	SK 36		SK 36
	SK 39	SK 39	SK 39		SK 39
	SK 45	SK 45	SK 45		SK 45
	SK 48	SK 48	SK 48		SK 48
	SK 52	SK 52	SK 52		SK 52
	SK 53	SK 53	SK 53		SK 53
	SK 55	SK 55	SK 55		SK 55
	SK 60	SK 60	SK 60		SK 60
	SK 63	SK 63	SK 63		SK 63
	SK 67	SK 69	SK 69		SK 69
	SK 69	SK 71	SK 71		SK 71
	SK 71	SK 72	SK 72		SK 72
	SK 72	SK 73	SK 73		SK 73
	SK 73	SK 74	SK 74		SK 74
	SK 74	SK 78	SK 78		SK 78
	SK 78	SK 79	SK 79		SK 79
	SK 79	SK 80	SK 80		SK 80
	SK 80	SK 122	SK 122		SK 122
	SK 84	SK 147	SK 147		SK 147
	SK 88	SK 148	SK 148		SK 148
	SK 97	SK 150	SK 150		SK 150
	SK 122	SK 165	SK 165		SK 165
	SK 124	SK 185	SK 185		SK 185
SK 147	SK 195	SK 195		SK 195	
SK 148	SK 197	SK 197		SK 197	
SK 150	SK 401	SK 401		SK 401	
SK 165	SK 402	SK 402		SK 402	
SK 185	SK 404	SK 404		SK 404	
SK 195					
SK 197					
SK 401					
SK 402					
SK 404					







Extruded heatsinks → A 22 - 83
 Heatsinks f. printed circuit boards → A 89 - 111
 Thermal conductive material → E 2 - 24
 Mount. material f. semiconductors → E 44 - 48

Die-cast heatsinks → A 125
 Reating springs for transistors → A 115 - 117
 Lock-in transistor fixing spring → A 84 - 88
 Technical introduction → A 2 - 8

Assignment table of transistor heatsinks

	TO 3 	TO 66 	SOT 9 	TO 5 	TO 247 	TO 3 P 
extruded heatsink with solder pins					SK 126 SK 145 SK 437 SK 459 SK 484	SK 104 SK 129 SK 400 SK 409 SK 448 SK 456 SK 484
extruded heatsinks	WP 4030				SK 126 SK 452	SK 452
set-up/clip-on heatsinks	AKK 127 AKK 191				FK 243 FK 245	
finger-shaped heatsinks	FK 201 FK 202 FK 205 FK 206 FK 223 FK 236	FK 201 FK 202 FK 205 FK 206 FK 207 FK 208 FK 217 FK 225 FK 234 FK 236	FK 201 FK 202 FK 205 FK 206 FK 207 FK 208 FK 217 FK 234 FK 236			
small heatsinks				KF KK 562 SKK		

Assignment table transistor heatsinks

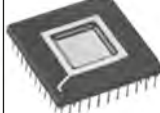
	TO 218 	TO 220 	SOT 32 	DIL 	PLCC 	P-SIP 	PGA/BGA 
U-heatsinks		ICK 35 SK 13 SK 431 UK 14	SK 12				assignment table → B 2 - 10
extruded heatsink with solder pin	SK 145 SK 437 SK 459 SK 460	SK 75 SK 104 SK 129 SK 145 SK 185 SK 409 SK 459 SK 460	SK 104 SK 129 SK 409 SK 459 SK 469 SK 470			SK 459 SK 460	
extruded heatsinks	SK 126 SK 452	SK 95 SK 126 SK 452 SK 454 SK 517 SK 518	SK 95 SK 454	ICK...B ICK..H ICK...L	ICK PLCC ICK R		
set-up/clip-on heatsinks	FK 224 FK 241 SK 516	FK 220 FK 224 FK 237 SK 515				FK 224 FK 241	
finger-shaped heatsinks	FK 224 FK 243 FK 245	FK 205 FK 206 FK 207 FK 208 FK 210 FK 212 FK 214 FK 216 FK 217 FK 218 FK 219 FK 220 FK 222 FK 225 FK 227 FK 228 FK 229 FK 230 FK 231 FK 232 FK 233 FK 234 FK 235 FK 247	FK 201 FK 205 FK 206 FK 207 FK 208 FK 209 FK 210 FK 211 FK 212 FK 213 FK 214 FK 215 FK 216 FK 217 FK 218 FK 219 FK 223 FK 234 FK 235 FK 236 FK 239			FK 224	
small heatsinks			KK 32 KK 92				

Extruded heatsinks → A 22 - 83
 Heatsinks f. printed circuit boards → A 89 - 112
 Thermal conductive material → E 2 - 24
 Mount. material f. semiconductors → E 44 - 48

Die-cast heatsinks → A 125
 Reating springs for transistors → A 115 - 117
 Lock-in transistor fixing spring → A 84 - 88
 Technical introduction → A 2 - 8

Hole pattern

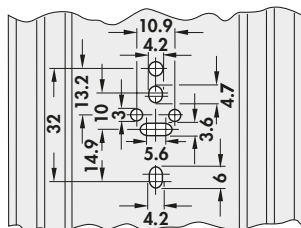
CB

CB = TO 3 + SOT 9 + TO 66 + SOT 32
at \leftrightarrow 37.5 mm oblique drilling

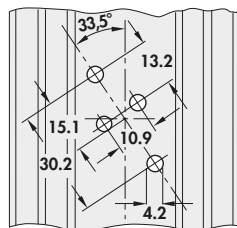
TO 3 S

TO 3 oblique drilling for \leftrightarrow 37.5 mm

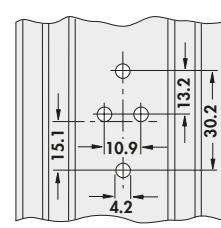
TO 3

TO 3 exceeding \leftrightarrow 50 mm

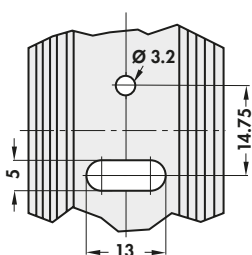
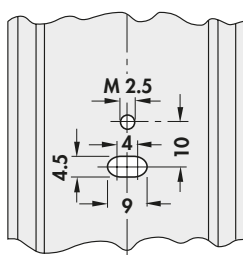
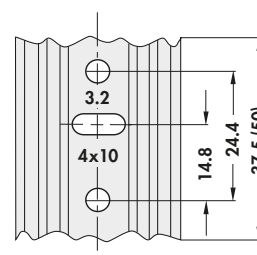
TO 220

SOT 32

K

SOT 32 / TO 220 exceeding \leftrightarrow 37.5 mm

Standard hole pattern are processed as complete pin layouts, centered on the length of the heatsink.

Other positions of the pin layout on the heatsink, multiple drillings or changes of the drillings are processed according to customer's requirements.

For heatsinks exceeding \leftrightarrow 75 mm standard hole pattern can be supplied in multiple design.

Fixing slots

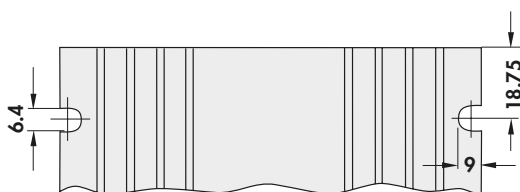

\leftrightarrow [mm]	number of fixing slots
37.5	2
75	4

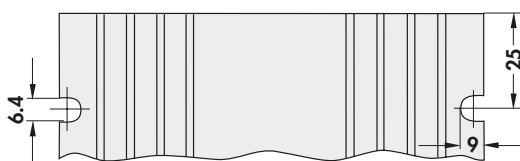

\leftrightarrow [mm]	number of fixing slots
50	2
100	4

Heatsinks with the following shape and a standard hole pattern have these fixing slots as part of the serial production

Order example



SK 01	50	SA	TO3
profile	length	surface	pin layout

Surface treatment for heatsinks with standard drilling: black anodised (SA).

Raw degreased aluminium (AL) and clear natural anodise (ME) on request.

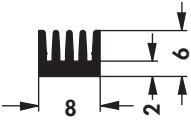
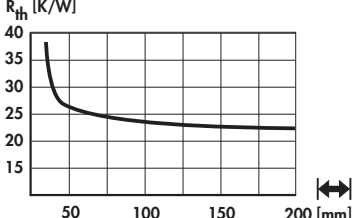
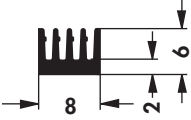
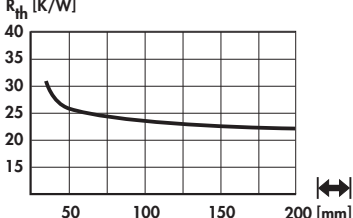
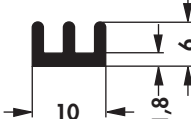
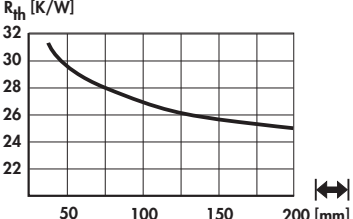

Standard extruded heatsinks

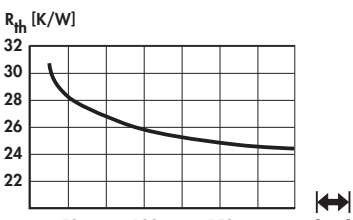
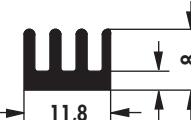
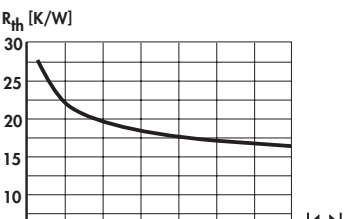
<p>art. no.</p> <p>SK 586 ...</p>		
<p>please indicate: ... $\left[\begin{array}{ c } \hline \text{---} \\ \hline \end{array} \right]$ 37.5 50 75 100 1000 mm</p>		
<p>art. no.</p> <p>SK 616 ...</p>		
<p>please indicate: ... $\left[\begin{array}{ c } \hline \text{---} \\ \hline \end{array} \right]$ 37.5 50 75 100 1000 mm</p>		
<p>art. no.</p> <p>SK 496 ...</p>		
<p>please indicate: ... $\left[\begin{array}{ c } \hline \text{---} \\ \hline \end{array} \right]$ 37.5 50 75 100 1000 mm</p>		
<p>art. no.</p> <p>SK 565 ...</p>		
<p>please indicate: ... $\left[\begin{array}{ c } \hline \text{---} \\ \hline \end{array} \right]$ 37.5 50 75 100 1000 mm</p>		
<p>art. no.</p> <p>SK 470 ...</p>		
<p>extruded heatsinks for PCB mounting → A 110</p>		
<p>please indicate: ... $\left[\begin{array}{ c } \hline \text{---} \\ \hline \end{array} \right]$ 25 37.5 50 75 100 1000 mm ... $\left[\begin{array}{ c } \hline \text{---} \\ \hline \end{array} \right]$ ⊕ (optional) SOT 32; TO 220</p>		

High decorative surfaces → A 9
 Order example → A 21
 Heatsink as visual & decor-parts → A 10
 Drilling pattern for Solid State Relais → A 12

Heatsinks for Solid State Relay → A 11 – 12
 Special heatsink design → A 137 – 138
 Special profiles → A 140
 Technical introduction → A 2 – 8

A 22



Standard extruded heatsinks

art. no.		
SK 522 ...	<p>please indicate: ... 15 25 37.5 50 1000 mm</p>	
art. no.		
SK 469 ...	extruded heatsinks for PCB mounting → A 110	
please indicate:	... 25 37.5 75 100 1000 mm	... (optional) SOT 32; TO 220
art. no.		
SK 478 ...	<p>please indicate: ... 25 37.5 50 75 1000 mm</p>	
art. no.		
SK 552 ...	<p>please indicate: ... 25 37.5 50 75 100 1000 mm</p>	
art. no.		
SK 558 ...	<p>please indicate: ... 25 37.5 50 75 100 1000 mm</p>	

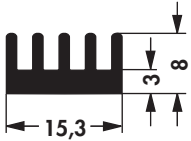
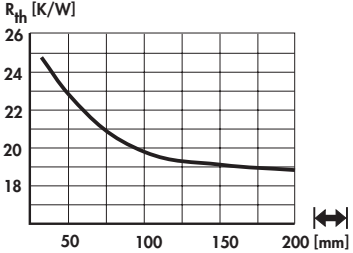
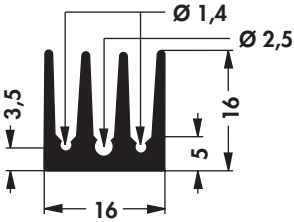
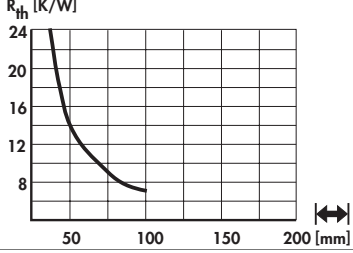
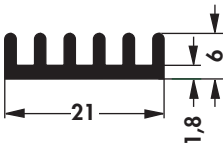
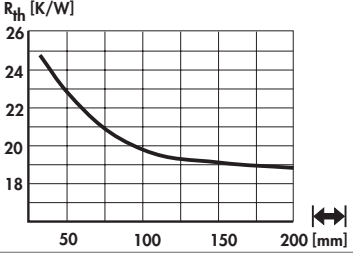
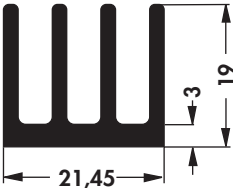
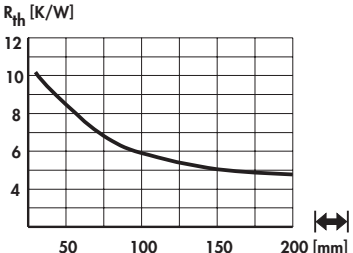
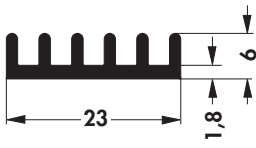
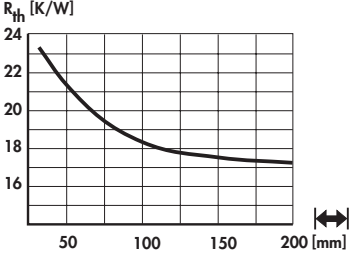

Standard extruded heatsinks

<p>art. no.</p> <p>SK 521 ...</p>		
<p>please indicate: ... $\left[\begin{array}{c} \text{---} \\ \text{---} \\ \text{---} \end{array} \right]$ 25 37.5 50 75 100 1000 mm</p>		
<p>art. no.</p> <p>SK 437 ...</p>		
<p>please indicate: ... $\left[\begin{array}{c} \text{---} \\ \text{---} \\ \text{---} \end{array} \right]$ 100 1000 mm ... $\left[\begin{array}{c} \text{---} \\ \text{---} \\ \text{---} \end{array} \right]$ (optional) TO 218; TO 220; TO 247; TO 248</p>		
<p>art. no.</p> <p>SK 476 ...</p>		
<p>please indicate: ... $\left[\begin{array}{c} \text{---} \\ \text{---} \\ \text{---} \end{array} \right]$ 37.5 50 75 100 1000 mm</p>		
<p>art. no.</p> <p>SK 454 ...</p>		
<p>please indicate: ... $\left[\begin{array}{c} \text{---} \\ \text{---} \\ \text{---} \end{array} \right]$ 37.5 50 75 100 150 1000 mm ... $\left[\begin{array}{c} \text{---} \\ \text{---} \\ \text{---} \end{array} \right]$ (optional) SOT 32; TO 220</p>		
<p>art. no.</p> <p>SK 477 ...</p>		
<p>please indicate: ... $\left[\begin{array}{c} \text{---} \\ \text{---} \\ \text{---} \end{array} \right]$ 37.5 50 100 1000 mm</p>		

High decorative surfaces → A 9
 Order example → A 21
 Heatsink as visual & decor-parts → A 10
 Drilling pattern for Solid State Relais → A 12

Heatsinks for Solid State Relay → A 11 – 12
 Special heatsink design → A 137 – 138
 Special profiles → A 140
 Technical introduction → A 2 – 8

A 24



Standard extruded heatsinks

<p>art. no.</p> <p>SK 582 ...</p>		
<p>please indicate: ... $\left[\begin{array}{c} \text{---} \\ \text{---} \end{array} \right]$</p> <p>37.5 50 75 100 1000 mm</p>		
<p>art. no.</p> <p>SK 559 ...</p>		
<p>please indicate: ... $\left[\begin{array}{c} \text{---} \\ \text{---} \end{array} \right]$</p> <p>37.5 75 100 1000 mm</p>		
<p>art. no.</p> <p>SK 551 ...</p>		
<p>please indicate: ... $\left[\begin{array}{c} \text{---} \\ \text{---} \end{array} \right]$</p> <p>37.5 50 75 100 1000 mm</p>		
<p>art. no.</p> <p>SK 486 ...</p>		
<p>please indicate: ... $\left[\begin{array}{c} \text{---} \\ \text{---} \end{array} \right]$</p> <p>37.5 50 75 100 1000 mm</p>		
<p>art. no.</p> <p>SK 473 ...</p>		
<p>please indicate: ... $\left[\begin{array}{c} \text{---} \\ \text{---} \end{array} \right]$</p> <p>37.5 50 75 1000 mm</p>		



Standard extruded heatsinks

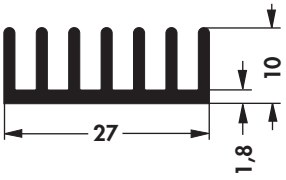
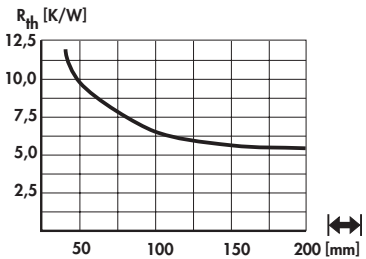
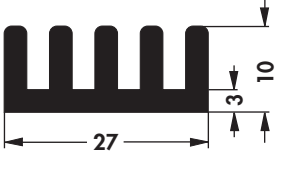
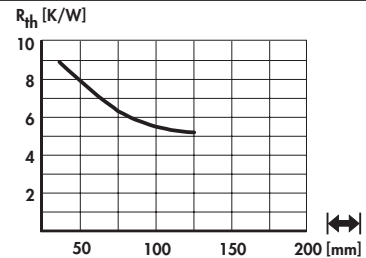
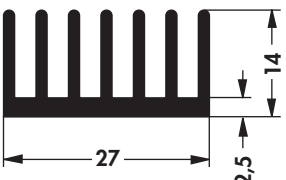
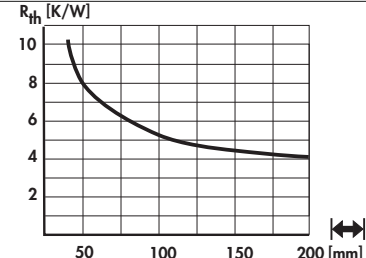
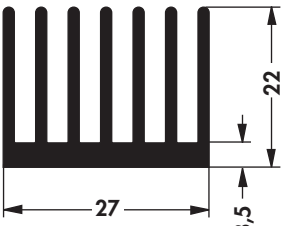
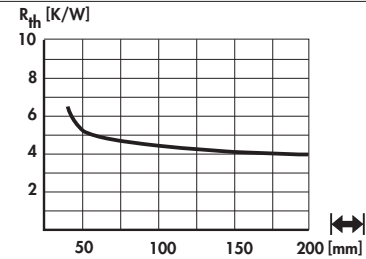
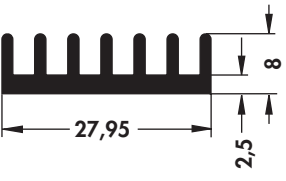
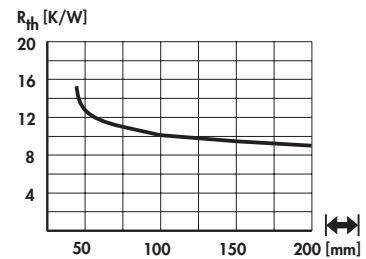







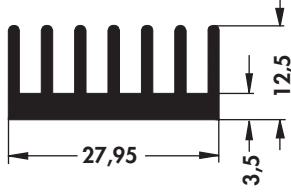
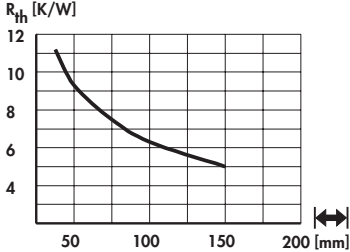

<p>art. no.</p> <p>SK 554 ...</p>		
<p>please indicate: ... \longleftrightarrow 37.5 50 75 100 1000 mm</p>		
<p>art. no.</p> <p>SK 447 ...</p>		
<p>please indicate: ... \longleftrightarrow 37.5 1000 mm</p>		
<p>art. no.</p> <p>SK 560 ...</p>		
<p>please indicate: ... \longleftrightarrow 37.5 50 75 100 1000 mm</p>		
<p>art. no.</p> <p>SK 566 ...</p>		
<p>please indicate: ... \longleftrightarrow 37.5 50 75 100 1000 mm</p>		
<p>art. no.</p> <p>SK 561 ...</p>		
<p>please indicate: ... \longleftrightarrow 37.5 50 75 100 1000 mm</p>		

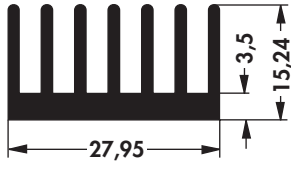
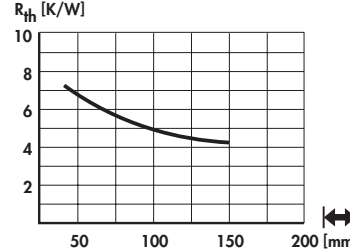
High decorative surfaces → A 9
 Order example → A 21
 Heatsink as visual & decor-parts → A 10
 Drilling pattern for Solid State Relais → A 12

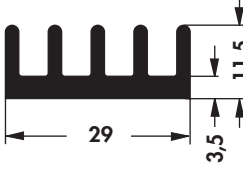
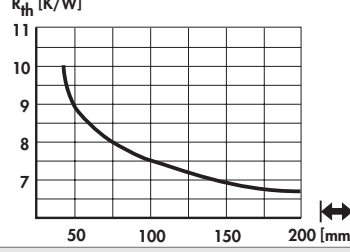
Heatsinks for Solid State Relay → A 11 – 12
 Special heatsink design → A 137 – 138
 Special profiles → A 140
 Technical introduction → A 2 – 8

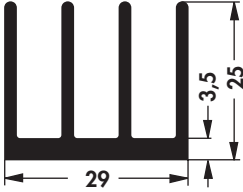
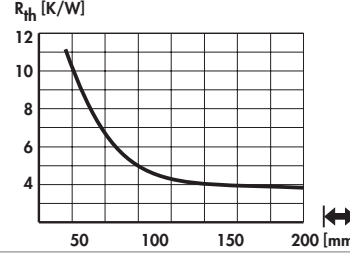

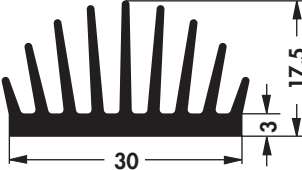
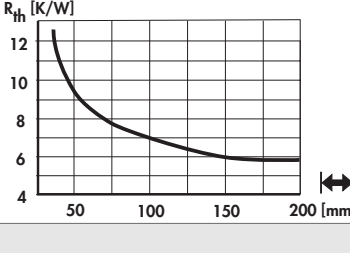
Standard extruded heatsinks

art. no.		
SK 448 ... extruded heatsinks for PCB mounting → A 111		
please indicate: ...  37.5 50 75 mm		
art. no.		
SK 177 ...		
please indicate: ...  50 75 100 1000 mm		
art. no.		
SK 550 ...		
please indicate: ...  37.5 50 75 100 1000 mm		
art. no.		
SK 452 ... extruded heatsinks for PCB mounting → A 96		
please indicate: ...  37.5 100 1000 mm		
...  (optional) TO 218; TO 220; TO 247; TO 248; TO 3 P		
art. no.		
SK 597 ...		
please indicate: ...  37.5 50 75 100 1000 mm		



Standard extruded heatsinks

<p>art. no.</p> <p>SK 493 ...</p>		
<p>please indicate: ... $\left[\begin{array}{c} \text{---} \\ \text{---} \end{array} \right]$ 37.5 50 75 100 1000 mm</p>		
<p>art. no.</p> <p>SK 581 ...</p>		
<p>please indicate: ... $\left[\begin{array}{c} \text{---} \\ \text{---} \end{array} \right]$ 37.5 50 75 100 1000 mm</p>		
<p>art. no.</p> <p>SK 400 ...</p>		
<p>extruded heatsinks for PCB mounting → A 111</p> <p>please indicate: ... $\left[\begin{array}{c} \text{---} \\ \text{---} \end{array} \right]$ 37.5 50 75 100 1000 mm</p>		
<p>art. no.</p> <p>SK 178 ...</p>		
<p>please indicate: ... $\left[\begin{array}{c} \text{---} \\ \text{---} \end{array} \right]$ 37.5 75 100 1000 mm</p>		
<p>art. no.</p> <p>SK 134 ...</p>		
<p>please indicate: ... $\left[\begin{array}{c} \text{---} \\ \text{---} \end{array} \right]$ 37.5 50 100 1000 mm</p>		

High decorative surfaces → A 9
 Order example → A 21
 Heatsink as visual & decor-parts → A 10
 Drilling pattern for Solid State Relays → A 12

Heatsinks for Solid State Relay → A 11 – 12
 Special heatsink design → A 137 – 138
 Special profiles → A 140
 Technical introduction → A 2 – 8



Standard extruded heatsinks

art. no. SK 471 ...		
please indicate: ... 37.5 50 75 100 1000 mm		
art. no. SK 587 ...		
please indicate: ... 37.5 50 75 100 1000 mm		
art. no. SK 549 ...		
please indicate: ... 37.5 50 75 100 1000 mm		
art. no. SK 562 ...		
please indicate: ... 37.5 50 75 100 1000 mm		
art. no. SK 509 ...		
please indicate: ... 37.5 50 100 1000 mm		



Standard extruded heatsinks

<p>art. no.</p> <p>SK 563 ...</p>		
<p>please indicate: ... $\overline{\hspace{1cm}}$</p> <p>37.5 50 75 100 1000 mm</p>		
<p>art. no.</p> <p>SK 564 ...</p>		
<p>please indicate: ... $\overline{\hspace{1cm}}$</p> <p>37.5 50 75 100 1000 mm</p>		
<p>art. no.</p> <p>SK 174 ...</p>		
<p>please indicate: ... $\overline{\hspace{1cm}}$</p> <p>75 1000 mm</p>		
<p>art. no.</p> <p>SK 179 ...</p>		
<p>please indicate: ... $\overline{\hspace{1cm}}$</p> <p>37.5 50 100 1000 mm</p>		
<p>art. no.</p> <p>SK 456 ...</p>		
<p>extruded heatsinks for PCB mounting → A 111</p> <p>please indicate: ... $\overline{\hspace{1cm}}$</p> <p>37.5 50 75 100 1000 mm</p>		

High decorative surfaces → A 9
 Order example → A 21
 Heatsink as visual & decor-parts → A 10
 Drilling pattern for Solid State Relays → A 12

Heatsinks for Solid State Relay → A 11 – 12
 Special heatsink design → A 137 – 138
 Special profiles → A 140
 Technical introduction → A 2 – 8

A 30

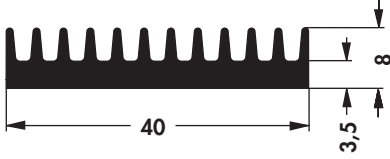
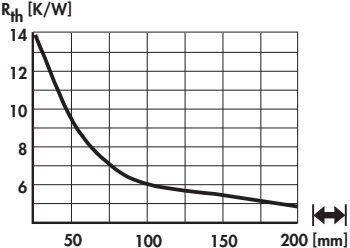
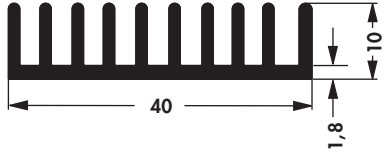
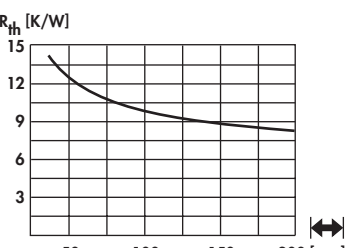
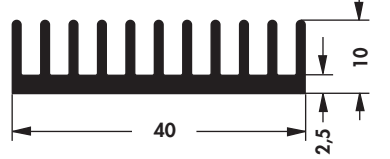
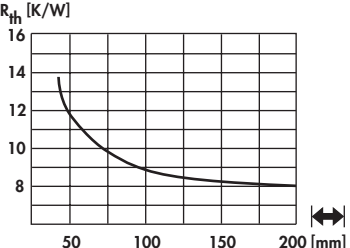
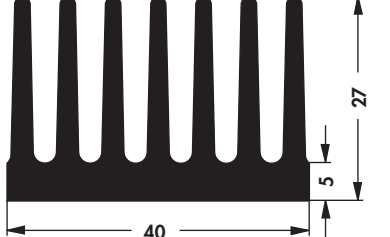
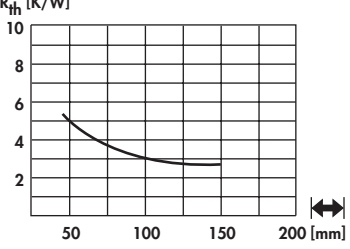
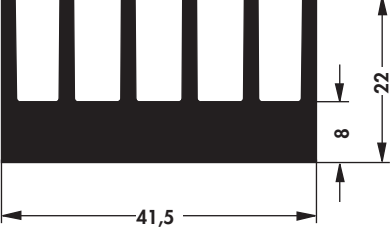
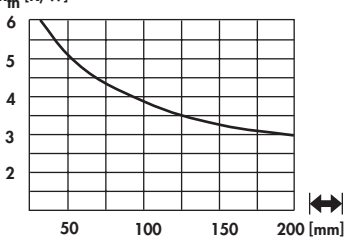

Standard extruded heatsinks

art. no. SK 420 ...		
<p>please indicate: ... 37.5 75 1000 mm</p>		
art. no. SK 513 ...		
<p>please indicate: ... 37.5 50 75 100 1000 mm</p>		
art. no. SK 547 ...		
<p>please indicate: ... 37.5 50 75 100 1000 mm</p>		
art. no. SK 106 ...		
<p>please indicate: ... 50 75 1000 mm</p>		
art. no. SK 472 ...		
<p>please indicate: ... 37.5 50 75 100 1000 mm</p>		



Standard extruded heatsinks

<p>art. no.</p> <p>SK 189 ...</p>		
<p>please indicate: ... $\left[\begin{array}{c} \text{---} \\ \text{---} \end{array} \right]$ 37.5 50 75 100 1000 mm</p>		
<p>art. no.</p> <p>SK 423 ...</p>		
<p>please indicate: ... $\left[\begin{array}{c} \text{---} \\ \text{---} \end{array} \right]$ 100 1000 mm</p>		
<p>art. no.</p> <p>SK 422 ...</p>		
<p>please indicate: ... $\left[\begin{array}{c} \text{---} \\ \text{---} \end{array} \right]$ 50 1000 mm</p>		
<p>art. no.</p> <p>SK 511 ...</p>		
<p>please indicate: ... $\left[\begin{array}{c} \text{---} \\ \text{---} \end{array} \right]$ 50 75 100 1000 mm</p>		

High decorative surfaces → A 9
 Order example → A 21
 Heatsink as visual & decor-parts → A 10
 Drilling pattern for Solid State Relais → A 12

Heatsinks for Solid State Relay → A 11 – 12
 Special heatsink design → A 137 – 138
 Special profiles → A 140
 Technical introduction → A 2 – 8

→ A 11 – 12
 → A 137 – 138
 → A 140
 → A 2 – 8



Standard extruded heatsinks

<p>art. no.</p> <p>SK 453 ...</p>		
<p>please indicate: ... $\left[\begin{array}{c} \text{---} \\ \text{---} \end{array} \right]$ 37.5 75 mm ... \varnothing (optional) SSR 1</p>		
<p>art. no.</p> <p>SK 455 ...</p>		
<p>please indicate: ... $\left[\begin{array}{c} \text{---} \\ \text{---} \end{array} \right]$ 75 mm ... \varnothing (optional) SSR 4</p>		
<p>art. no.</p> <p>SK 467 ...</p>		
<p>please indicate: ... $\left[\begin{array}{c} \text{---} \\ \text{---} \end{array} \right]$ 37.5 50 75 100 1000 mm ... \varnothing (optional) SSR 1; SSR 4</p>		

A 33

High decorative surfaces → A 9
 Order example → A 21
 Heatsink as visual & decor-parts → A 10
 Drilling pattern for Solid State Relais → A 12

Heatsinks for Solid State Relay → A 11 – 12
 Special heatsink design → A 137 – 138
 Special profiles → A 140
 Technical introduction → A 2 – 8



Standard extruded heatsinks

<p>art. no.</p> <p>SK 424 ...</p>		
<p>please indicate: ... $\overline{\quad}$ 75 1000 mm</p>		
<p>art. no.</p> <p>SK 425 ...</p>		
<p>please indicate: ... $\overline{\quad}$ 75 mm</p>		
<p>art. no.</p> <p>SK 445 ...</p>		
<p>please indicate: ... $\overline{\quad}$ 100 1000 mm</p>		
<p>art. no.</p> <p>SK 450 ...</p>		
<p>please indicate: ... $\overline{\quad}$ 75 1000 mm</p>		
<p>art. no.</p> <p>SK 548 ...</p>		
<p>please indicate: ... $\overline{\quad}$ 37.5 50 75 100 1000 mm</p>		

High decorative surfaces → A 9
 Order example → A 21
 Heatsink as visual & decor-parts → A 10
 Drilling pattern for Solid State Relays → A 12

Heatsinks for Solid State Relay → A 11 – 12
 Special heatsink design → A 137 – 138
 Special profiles → A 140
 Technical introduction → A 2 – 8

A 34



Standard extruded heatsinks

art. no. SK 567 ...		
<p>please indicate: ... $\left[\begin{array}{c} \text{---} \\ \text{---} \\ \text{---} \end{array} \right]$ 37.5 50 75 100 1000 mm</p>		
art. no. SK 434 ...		
<p>please indicate: ... $\left[\begin{array}{c} \text{---} \\ \text{---} \\ \text{---} \end{array} \right]$... \diamond (optional) SSR 1 50 75 100 1000 mm</p>		
art. no. SK 475 ...		
<p>please indicate: ... $\left[\begin{array}{c} \text{---} \\ \text{---} \\ \text{---} \end{array} \right]$ 37.5 50 100 1000 mm</p>		
art. no. SK 527 ...		
<p>please indicate: ... $\left[\begin{array}{c} \text{---} \\ \text{---} \\ \text{---} \end{array} \right]$ 50 75 100 1000 mm</p>		

A 35

High decorative surfaces → A 9
 Order example → A 21
 Heatsink as visual & decor-parts → A 10
 Drilling pattern for Solid State Relais → A 12

Heatsinks for Solid State Relay → A 11 - 12
 Special heatsink design → A 137 - 138
 Special profiles → A 140
 Technical introduction → A 2 - 8



Standard extruded heatsinks







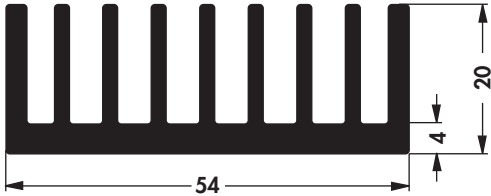
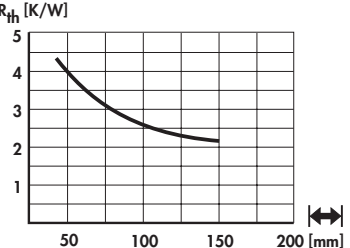

<p>art. no.</p> <p>SK 427 ...</p>		
<p>please indicate: ... $\left[\begin{array}{c} \text{---} \\ \text{---} \end{array} \right]$ 50 75 1000 mm</p>		
<p>art. no.</p> <p>SK 426 ...</p>		
<p>please indicate: ... $\left[\begin{array}{c} \text{---} \\ \text{---} \end{array} \right]$ 37.5 50 75 100 1000 mm</p>		
<p>art. no.</p> <p>SK 156 ...</p>		
<p>please indicate: ... $\left[\begin{array}{c} \text{---} \\ \text{---} \end{array} \right]$ 37.5 50 75 100 1000 mm</p>		
<p>art. no.</p> <p>SK 468 ...</p>		
<p>please indicate: ... $\left[\begin{array}{c} \text{---} \\ \text{---} \end{array} \right]$ 37.5 75 1000 mm</p>		
<p>art. no.</p> <p>SK 180 ...</p>		
<p>please indicate: ... $\left[\begin{array}{c} \text{---} \\ \text{---} \end{array} \right]$ 37.5 50 75 100 1000 mm</p>		

High decorative surfaces → A 9
 Order example → A 21
 Heatsink as visual & decor-parts → A 10
 Drilling pattern for Solid State Relays → A 12

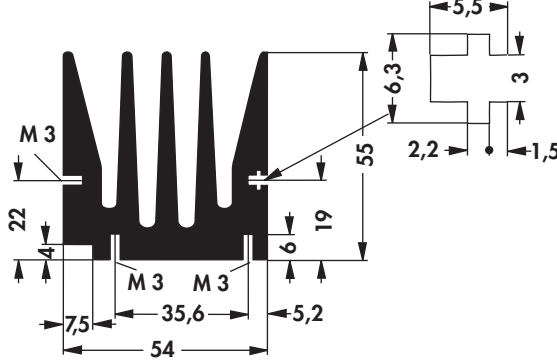
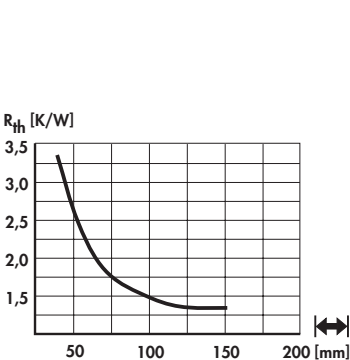
Heatsinks for Solid State Relay → A 11 – 12
 Special heatsink design → A 137 – 138
 Special profiles → A 140
 Technical introduction → A 2 – 8

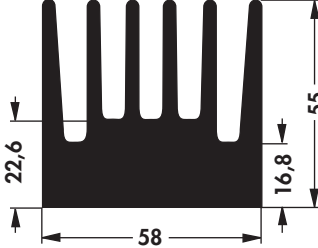
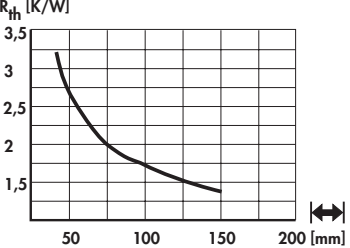

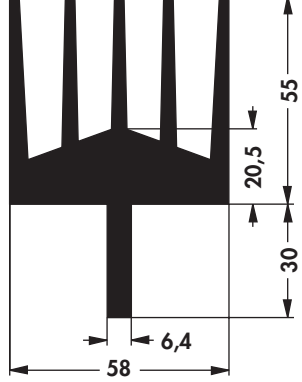
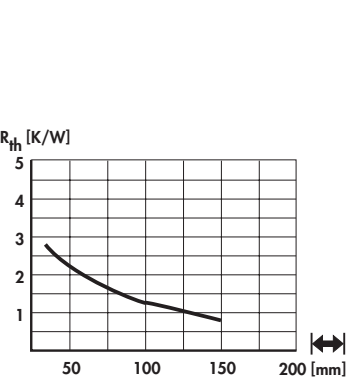







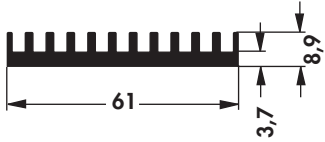
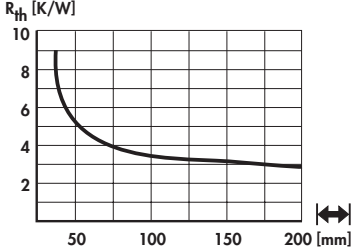

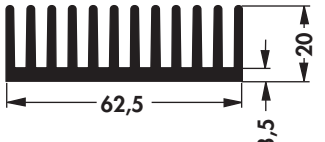
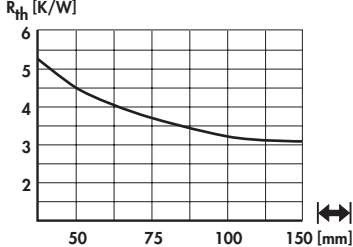
Standard extruded heatsinks

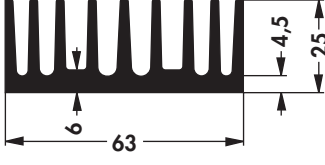
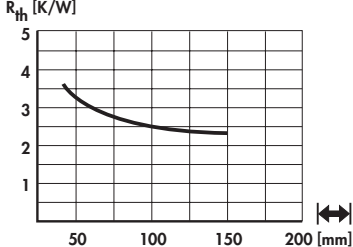
art. no. SK 99 ...		
please indicate: ...  37.5 50 75 100 150 1000 mm		
art. no. SK 429 ...		
please indicate: ...  37.5 50 75 100 1000 mm		
art. no. SK 436 ...		
please indicate: ...  75 1000 mm		
art. no. SK 50 ...		
please indicate: ...  75 1000 mm		

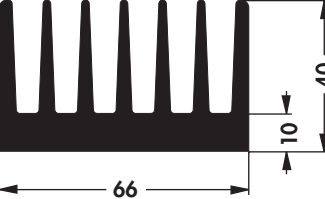
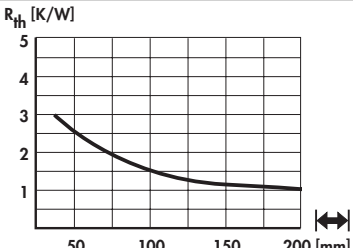

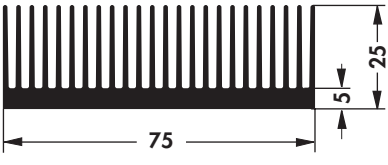
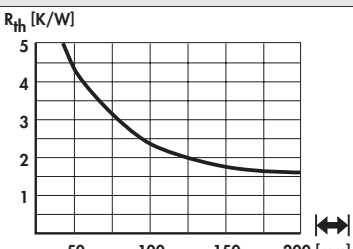
Standard extruded heatsinks









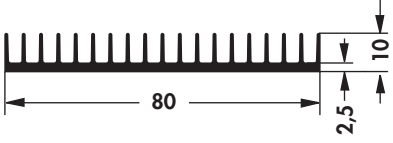
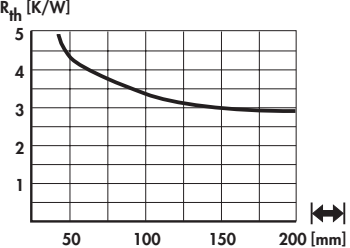

<p>art. no.</p> <p>SK 485 ...</p>		
<p>please indicate: ...  50 75 100 1000 mm</p>		
<p>art. no.</p> <p>SK 444 ...</p>		
<p>please indicate: ...  37.5 50 75 1000 mm</p>		
<p>art. no.</p> <p>SK 406 ...</p>		
<p>please indicate: ...  37.5 50 75 100 1000 mm</p>		
<p>art. no.</p> <p>SK 100 ...</p>		
<p>please indicate: ...  37.5 50 75 100 150 1000 mm</p>		
<p>art. no.</p> <p>SK 594 ...</p>		
<p>please indicate: ...  37.5 50 75 100 1000 mm</p>		

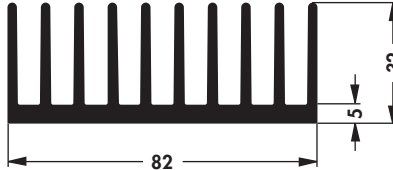
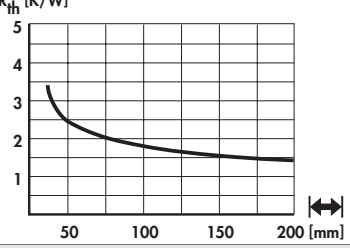
High decorative surfaces → A 9
 Order example → A 21
 Heatsink as visual & decor-parts → A 10
 Drilling pattern for Solid State Relays → A 12

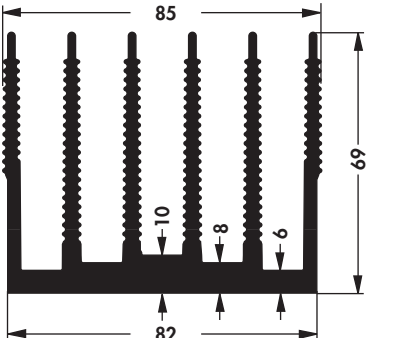
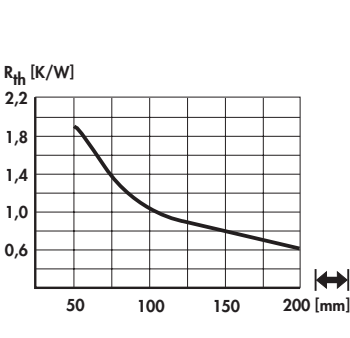
Heatsinks for Solid State Relay → A 11 – 12
 Special heatsink design → A 137 – 138
 Special profiles → A 140
 Technical introduction → A 2 – 8

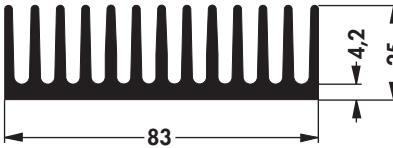
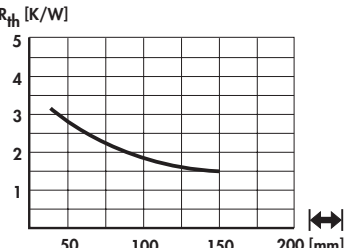

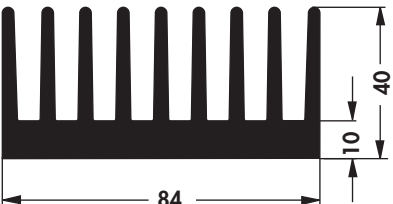
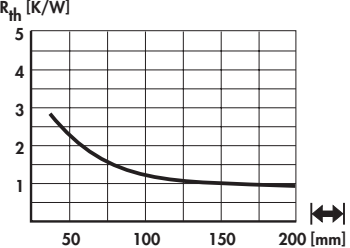
Standard extruded heatsinks

art. no. SK 545 ...		
please indicate: ...  50 75 100 150 1000 mm		
art. no. SK 612 ...		
please indicate: ...  37.5 50 75 100 150 1000 mm		
art. no. SK 135 ...		
please indicate: ...  50 100 1000 mm		
art. no. SK 407 ...		
please indicate: ...  37.5 50 75 100 1000 mm		
art. no. SK 464 ...		
please indicate: ...  50 75 100 150 1000 mm		



Standard extruded heatsinks

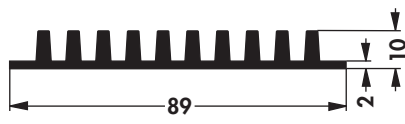
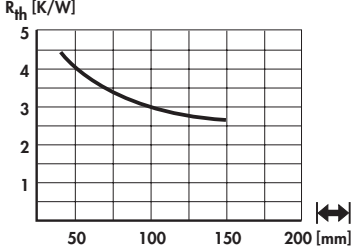
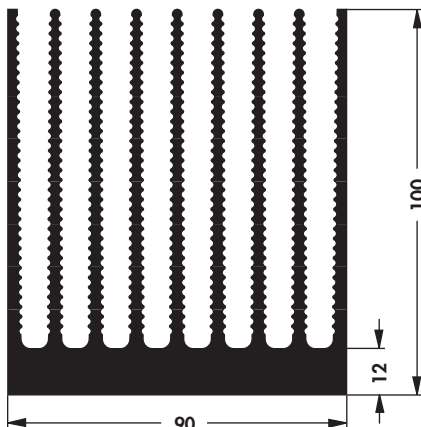
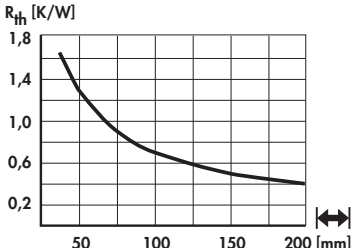
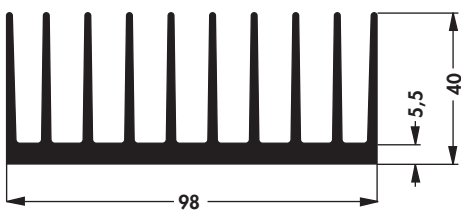
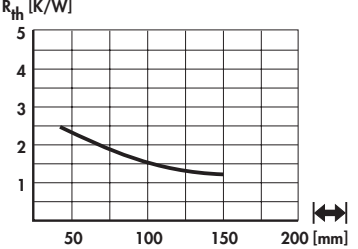
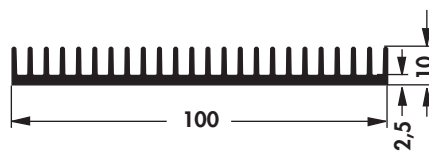
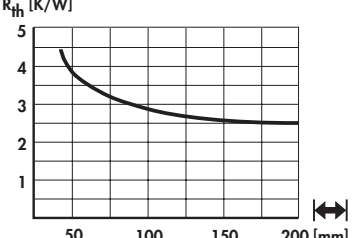







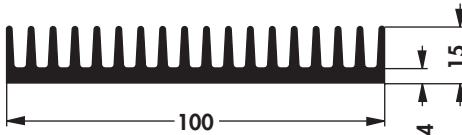
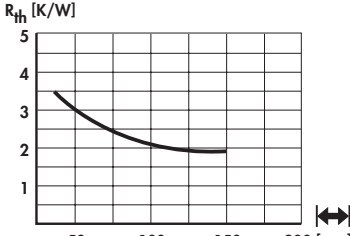

<p>art. no.</p> <p>SK 182 ...</p>		
<p>please indicate: ... $\left[\begin{array}{c} \text{---} \\ \text{---} \end{array} \right]$ 37.5 50 75 100 150 200 1000 mm</p>		
<p>art. no.</p> <p>SK 507 ...</p>		
<p>please indicate: ... $\left[\begin{array}{c} \text{---} \\ \text{---} \end{array} \right]$ 37.5 75 100 1000 mm ... \diamond (optional) SSR 1; SSR 2</p>		
<p>art. no.</p> <p>SK 408 ...</p>		
<p>please indicate: ... $\left[\begin{array}{c} \text{---} \\ \text{---} \end{array} \right]$ 50 75 100 150 1000 mm</p>		
<p>art. no.</p> <p>SK 546 ...</p>		
<p>please indicate: ... $\left[\begin{array}{c} \text{---} \\ \text{---} \end{array} \right]$ 37.5 50 75 100 150 1000 mm</p>		

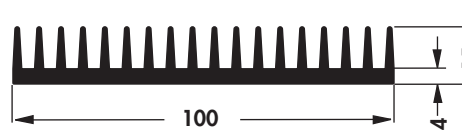
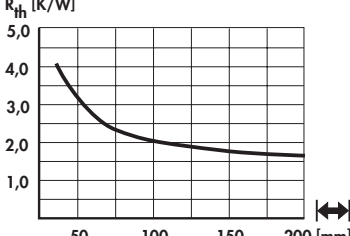
High decorative surfaces → A 9
 Order example → A 21
 Heatsink as visual & decor-parts → A 10
 Drilling pattern for Solid State Relays → A 12

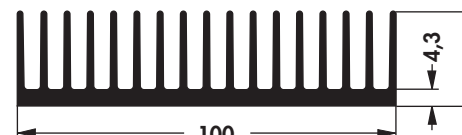
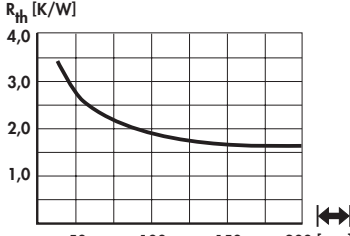
Heatsinks for Solid State Relay → A 11 – 12
 Special heatsink design → A 137 – 138
 Special profiles → A 140
 Technical introduction → A 2 – 8

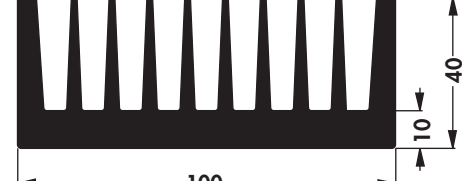
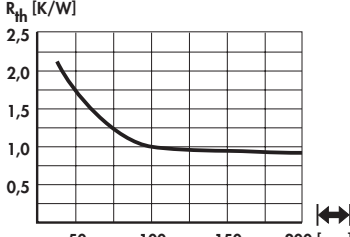

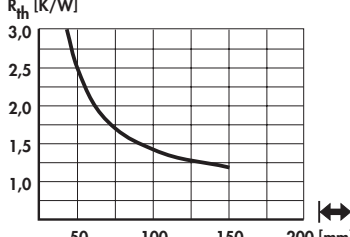
Standard extruded heatsinks

art. no. SK 81 ...		
please indicate: ...  37.5 50 75 100 1000 mm		
art. no. SK 505 ...		
weight reduced like SK 81		
please indicate: ...  37.5 50 75 100 150 1000 mm		
art. no. SK 508 ...		
please indicate: ...  37.5 50 75 100 1000 mm		
art. no. SK 92 ...		
please indicate: ...  50 75 100 150 1000 mm		
art. no. SK 433 ...		
please indicate: ...  37.5 50 75 1000 mm		



Standard extruded heatsinks

<p>art. no.</p> <p>SK 121 ...</p>		
<p>please indicate: ... $\left[\begin{array}{c} \text{---} \\ \text{---} \\ \text{---} \end{array} \right]$ 75 100 150 1000 mm</p>		
<p>art. no.</p> <p>SK 33 ...</p>		
<p>please indicate: ... $\left[\begin{array}{c} \text{---} \\ \text{---} \\ \text{---} \end{array} \right]$... \diamond (optional) 50 75 100 1000 mm SSR 1</p>		
<p>art. no.</p> <p>SK 411 ...</p>		
<p>please indicate: ... $\left[\begin{array}{c} \text{---} \\ \text{---} \\ \text{---} \end{array} \right]$ 50 75 100 150 1000 mm</p>		
<p>art. no.</p> <p>SK 442 ...</p>		
<p>please indicate: ... $\left[\begin{array}{c} \text{---} \\ \text{---} \\ \text{---} \end{array} \right]$ 50 75 100 150 1000 mm</p>		

High decorative surfaces → A 9
 Order example → A 21
 Heatsink as visual & decor-parts → A 10
 Drilling pattern for Solid State Relays → A 12

Heatsinks for Solid State Relay → A 11 – 12
 Special heatsink design → A 137 – 138
 Special profiles → A 140
 Technical introduction → A 2 – 8



Standard extruded heatsinks

art. no. SK 595 ...		
please indicate: ... 50 75 100 150 1000 mm		
art. no. SK 463 ...		
please indicate: ... 50 75 100 150 1000 mm		
art. no. SK 613 ...		
please indicate: ... 37.5 50 75 100 150 1000 mm		
art. no. SK 466 ...		
please indicate: ... 50 75 100 150 1000 mm		
art. no. SK 413 ...		
please indicate: ... 100 1000 mm		



Standard extruded heatsinks

<p>art. no.</p> <p>SK 601 ...</p>		
<p>please indicate: ... $\left[\begin{array}{c} \text{---} \\ \text{---} \end{array} \right]$ 50 75 100 150 1000 mm</p>		
<p>art. no.</p> <p>SK 553 ...</p>		
<p>please indicate: ... $\left[\begin{array}{c} \text{---} \\ \text{---} \end{array} \right]$ 37.5 50 75 100 150 1000 mm</p>		
<p>art. no.</p> <p>SK 132 ...</p>		
<p>please indicate: ... $\left[\begin{array}{c} \text{---} \\ \text{---} \end{array} \right]$ 37.5 50 75 100 150 1000 mm</p>		
<p>art. no.</p> <p>SK 410 ...</p>		
<p>please indicate: ... $\left[\begin{array}{c} \text{---} \\ \text{---} \end{array} \right]$ 37.5 50 75 100 150 1000 mm</p>		
<p>art. no.</p> <p>SK 133 ...</p>		
<p>please indicate: ... $\left[\begin{array}{c} \text{---} \\ \text{---} \end{array} \right]$ 50 75 100 1000 mm</p>		

High decorative surfaces → A 9
 Order example → A 21
 Heatsink as visual & decor-parts → A 10
 Drilling pattern for Solid State Relais → A 12

Heatsinks for Solid State Relay → A 11 – 12
 Special heatsink design → A 137 – 138
 Special profiles → A 140
 Technical introduction → A 2 – 8



Standard extruded heatsinks

art. no. SK 58 ...		
please indicate: ... 50 75 100 150 1000 mm		
art. no. SK 504 ...		
SK 504 ... weight reduced like SK 58		
please indicate: ... 37.5 50 75 100 150 1000 mm		
art. no. SK 588 ...		
please indicate: ... 50 75 100 150 1000 mm		
art. no. SK 120 ...		
please indicate: ... 50 75 100 150 1000 mm		
art. no. SK 155 ...		
please indicate: ... 75 100 150 1000 mm		



Standard extruded heatsinks

<p>art. no.</p> <p>SK 154 ...</p>		
<p>please indicate: ... $\left[\begin{array}{c} \text{---} \\ \text{---} \end{array} \right]$ 50 75 100 150 mm</p>		
<p>art. no.</p> <p>SK 417 ...</p>		
<p>please indicate: ... $\left[\begin{array}{c} \text{---} \\ \text{---} \end{array} \right]$ 75 100 150 1000 mm</p>		
<p>art. no.</p> <p>SK 85 ...</p>		
<p>please indicate: ... $\left[\begin{array}{c} \text{---} \\ \text{---} \end{array} \right]$ 37.5 50 75 100 150 1000 mm</p>		
<p>art. no.</p> <p>SK 503 ...</p>		
<p>weight reduced like SK 85</p>		
<p>please indicate: ... $\left[\begin{array}{c} \text{---} \\ \text{---} \end{array} \right]$ 75 100 1000 mm</p>		
<p>art. no.</p> <p>SK 510 ...</p>		
<p>please indicate: ... $\left[\begin{array}{c} \text{---} \\ \text{---} \end{array} \right]$ 50 75 100 150 1000 mm</p>		

High decorative surfaces → A 9
 Order example → A 21
 Heatsink as visual & decor-parts → A 10
 Drilling pattern for Solid State Relais → A 12

Heatsinks for Solid State Relay → A 11 – 12
 Special heatsink design → A 137 – 138
 Special profiles → A 140
 Technical introduction → A 2 – 8

A 46



Standard extruded heatsinks

art. no. SK 416 ...		
please indicate: ... $\left[\begin{array}{c} \text{---} \\ \text{---} \end{array} \right]$ 50 75 100 150 1000 mm		
art. no. SK 119 ...		
please indicate: ... $\left[\begin{array}{c} \text{---} \\ \text{---} \end{array} \right]$ 50 75 100 150 1000 mm		
art. no. SK 412 ...		
please indicate: ... $\left[\begin{array}{c} \text{---} \\ \text{---} \end{array} \right]$ 50 75 100 150 1000 mm		
art. no. SK 421 ...		
please indicate: ... $\left[\begin{array}{c} \text{---} \\ \text{---} \end{array} \right]$ 50 75 100 150 200 1000 mm		
art. no. SK 405 ...		
please indicate: ... $\left[\begin{array}{c} \text{---} \\ \text{---} \end{array} \right]$ 100 1000 mm		



Standard extruded heatsinks









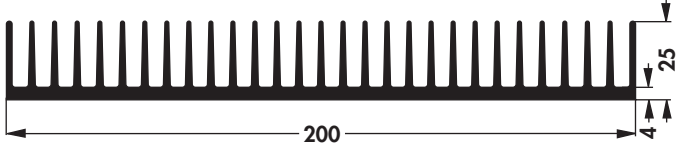
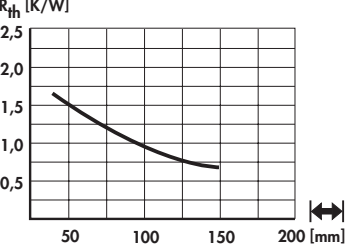

<p>art. no.</p> <p>SK 519 ...</p>		
<p>please indicate: ... $\left[\begin{array}{ c } \hline \text{---} \\ \hline \end{array} \right]$ 50 100 1000 mm</p>		
<p>art. no.</p> <p>SK 90 ...</p>		
<p>please indicate: ... $\left[\begin{array}{ c } \hline \text{---} \\ \hline \end{array} \right]$ 50 75 100 1000 mm</p>		
<p>art. no.</p> <p>SK 136 ...</p>		
<p>please indicate: ... $\left[\begin{array}{ c } \hline \text{---} \\ \hline \end{array} \right]$ 75 100 150 1000 mm</p>		
<p>art. no.</p> <p>SK 166 ...</p>		
<p>please indicate: ... $\left[\begin{array}{ c } \hline \text{---} \\ \hline \end{array} \right]$ 1000 mm</p>		
<p>art. no.</p> <p>SK 113 ...</p>		
<p>please indicate: ... $\left[\begin{array}{ c } \hline \text{---} \\ \hline \end{array} \right]$ 50 75 100 150 1000 mm</p>		

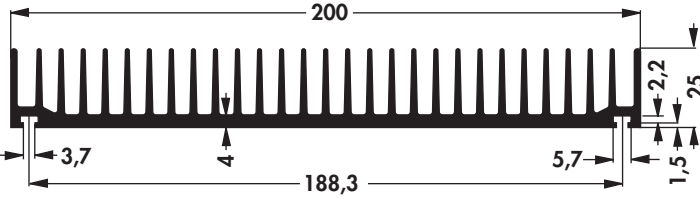
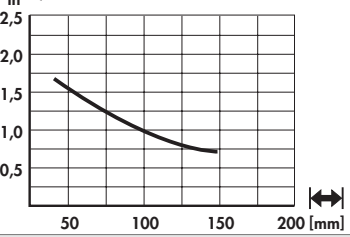
High decorative surfaces → A 9
 Order example → A 21
 Heatsink as visual & decor-parts → A 10
 Drilling pattern for Solid State Relays → A 12

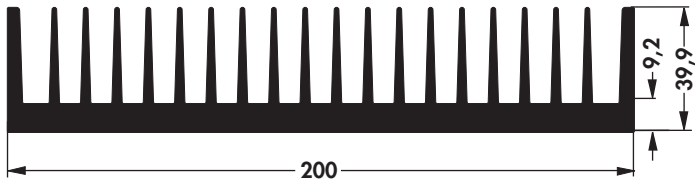
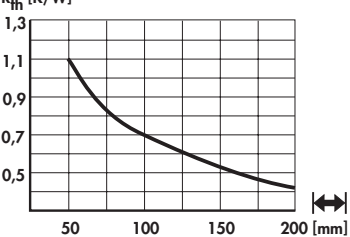
Heatsinks for Solid State Relay → A 11 – 12
 Special heatsink design → A 137 – 138
 Special profiles → A 140
 Technical introduction → A 2 – 8

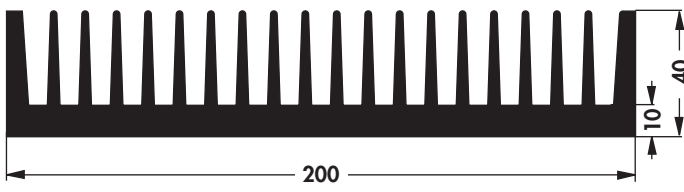
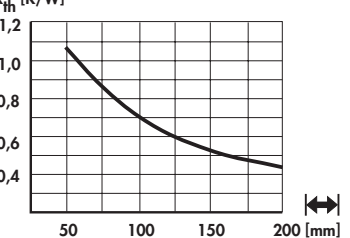

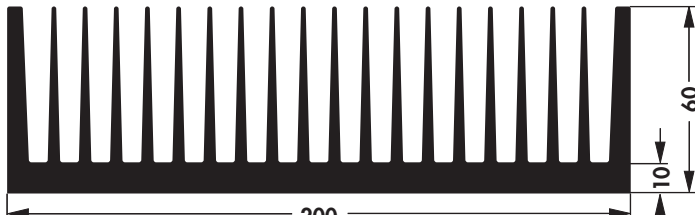
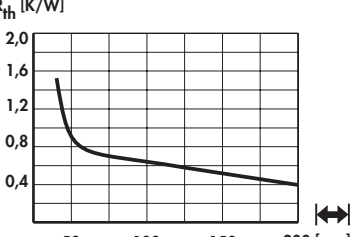
Standard extruded heatsinks

art. no. SK 42 ...		
<p>please indicate: ...  50 75 100 150 200 1000 mm</p>		
art. no. SK 94 ...		
<p>please indicate: ...  1000 mm</p>		
art. no. SK 502 ...		
<p>weight reduced like SK 47</p>		
<p>please indicate: ...  37.5 50 75 100 150 1000 mm</p>		
art. no. SK 47 ...		
<p>please indicate: ...  75 100 150 1000 mm</p>		
art. no. SK 591 ...		
<p>please indicate: ...  75 100 150 1000 mm</p>		



Standard extruded heatsinks

<p>art. no.</p> <p>SK 520 ...</p>		
<p>please indicate: ... $\left[\begin{array}{c} \text{---} \\ \text{---} \end{array} \right]$ 75 100 150 1000 mm</p>		
<p>art. no.</p> <p>SK 193 ...</p>		
<p>please indicate: ... $\left[\begin{array}{c} \text{---} \\ \text{---} \end{array} \right]$ 100 150 1000 mm</p>		
<p>art. no.</p> <p>SK 557 ...</p>		
<p>please indicate: ... $\left[\begin{array}{c} \text{---} \\ \text{---} \end{array} \right]$ 75 100 150 1000 mm</p>		
<p>art. no.</p> <p>SK 102 ...</p>		
<p>please indicate: ... $\left[\begin{array}{c} \text{---} \\ \text{---} \end{array} \right]$ 75 100 150 1000 mm</p>		
<p>art. no.</p> <p>SK 168 ...</p>		
<p>please indicate: ... $\left[\begin{array}{c} \text{---} \\ \text{---} \end{array} \right]$ 1000 mm</p>		









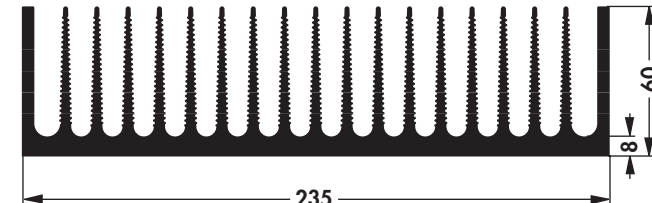
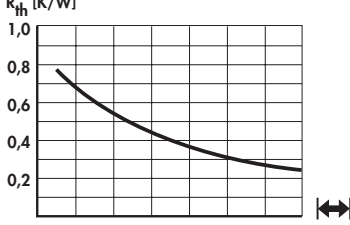

High decorative surfaces → A 9
 Order example → A 21
 Heatsink as visual & decor-parts → A 10
 Drilling pattern for Solid State Relais → A 12

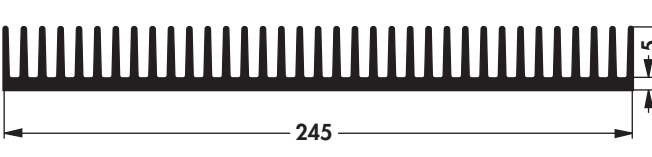
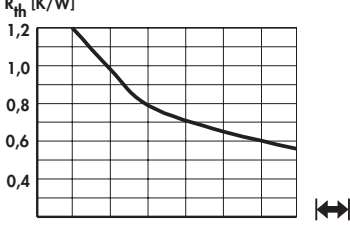
Heatsinks for Solid State Relay → A 11 – 12
 Special heatsink design → A 137 – 138
 Special profiles → A 140
 Technical introduction → A 2 – 8

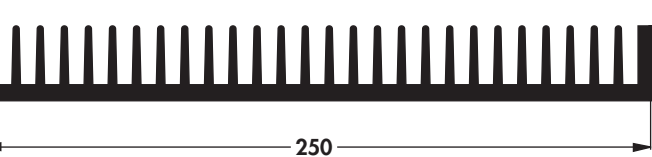
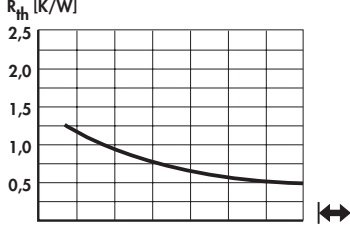
A 50

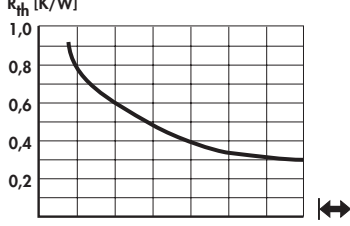

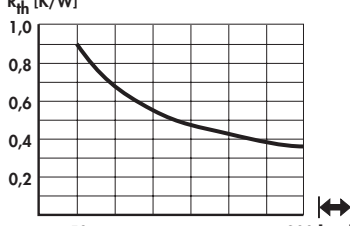
Standard extruded heatsinks

art. no. SK 580 ...		
<p>please indicate: ...  75 100 150 200 1000 mm</p>		
art. no. SK 118 ...		
<p>please indicate: ...  75 100 150 1000 mm</p>		
art. no. SK 49 ...		
<p>please indicate: ...  50 75 150 200 1000 mm</p>		
art. no. SK 555 ...		
<p>please indicate: ...  75 100 150 1000 mm</p>		
art. no. SK 199 ...		
<p>please indicate: ...  75 100 1000 mm</p>		



Standard extruded heatsinks

<p>art. no.</p> <p>SK 524 ...</p>		
<p>please indicate: ... $\left[\begin{array}{c} \text{---} \\ \text{---} \end{array} \right]$</p> <p>75 100 150 1000 mm</p>		
<p>art. no.</p> <p>SK 91 ...</p>		
<p>please indicate: ... $\left[\begin{array}{c} \text{---} \\ \text{---} \end{array} \right]$</p> <p>75 100 150 1000 mm</p>		
<p>art. no.</p> <p>SK 438 ...</p>		
<p>please indicate: ... $\left[\begin{array}{c} \text{---} \\ \text{---} \end{array} \right]$</p> <p>75 100 150 1000 mm</p>		
<p>art. no.</p> <p>SK 190 ...</p>		
<p>please indicate: ... $\left[\begin{array}{c} \text{---} \\ \text{---} \end{array} \right]$</p> <p>150 1000 mm</p>		
<p>art. no.</p> <p>SK 614 ...</p>		
<p>please indicate: ... $\left[\begin{array}{c} \text{---} \\ \text{---} \end{array} \right]$</p> <p>75 100 150 200 1000 mm</p>		

High decorative surfaces → A 9
 Order example → A 21
 Heatsink as visual & decor-parts → A 10
 Drilling pattern for Solid State Relais → A 12

Heatsinks for Solid State Relay → A 11 – 12
 Special heatsink design → A 137 – 138
 Special profiles → A 140
 Technical introduction → A 2 – 8



Standard extruded heatsinks

art. no. SK 149 ...		
please indicate: ... \longleftrightarrow 200 1000 mm		
art. no. SK 139 ...		
please indicate: ... \longleftrightarrow 100 150 200 1000 mm		
art. no. SK 583 ...		
please indicate: ... \longleftrightarrow 100 150 200 1000 mm		
art. no. SK 198 ...		
please indicate: ... \longleftrightarrow 100 150 1000 mm		
art. no. SK 446 ...		
please indicate: ... \longleftrightarrow 75 100 150 1000 mm		



Standard extruded heatsinks

<p>art. no.</p> <p>SK 56 ...</p>		
<p>please indicate: ... $\left[\begin{array}{c} \text{---} \\ \text{---} \end{array} \right]$</p> <p>75 100 150 200 1000 mm</p>		
<p>art. no.</p> <p>SK 501 ...</p>		
<p>weight reduced like SK 56</p>		
<p>please indicate: ... $\left[\begin{array}{c} \text{---} \\ \text{---} \end{array} \right]$</p> <p>37.5 50 75 100 150 200 1000 mm</p>		
<p>art. no.</p> <p>SK 568 ...</p>		
<p>please indicate: ... $\left[\begin{array}{c} \text{---} \\ \text{---} \end{array} \right]$</p> <p>75 100 150 200 1000 mm</p>		
<p>art. no.</p> <p>SK 157 ...</p>		
<p>please indicate: ... $\left[\begin{array}{c} \text{---} \\ \text{---} \end{array} \right]$</p> <p>100 150 200 1000 mm</p>		
<p>art. no.</p> <p>SK 101 ...</p>		
<p>please indicate: ... $\left[\begin{array}{c} \text{---} \\ \text{---} \end{array} \right]$</p> <p>75 100 1000 mm</p>		

High decorative surfaces → A 9
 Order example → A 21
 Heatsink as visual & decor-parts → A 10
 Drilling pattern for Solid State Relais → A 12

Heatsinks for Solid State Relay → A 11 – 12
 Special heatsink design → A 137 – 138
 Special profiles → A 140
 Technical introduction → A 2 – 8



Standard extruded heatsinks

art. no. SK 579 ...		
please indicate: ... 75 100 150 200 1000 mm		
art. no. SK 66 ...		
please indicate: ... 75 100 1000 mm		
art. no. SK 523 ...		
please indicate: ... 100 150 200 1000 mm		
art. no. SK 439 ...		
please indicate: ... 100 150 1000 mm		
art. no. SK 479 ...		
please indicate: ... 75 100 150 1000 mm		



Standard extruded heatsinks

<p>art. no. SK 93 ...</p>		
<p>please indicate: ... $\left[\begin{array}{c} \text{---} \\ \text{---} \end{array} \right]$ 75 100 150 1000 mm</p>		
<p>art. no. SK 130 ...</p>		
<p>please indicate: ... $\left[\begin{array}{c} \text{---} \\ \text{---} \end{array} \right]$ 200 1000 mm</p>		
<p>art. no. SK 621 ...</p>		
<p>please indicate: ... $\left[\begin{array}{c} \text{---} \\ \text{---} \end{array} \right]$ 75 100 150 200 1000 mm</p>		
<p>art. no. SK 191 ...</p>		
<p>suitable heatsink for rear panel in 19" cases</p>		
<p>please indicate: ... $\left[\begin{array}{c} \text{---} \\ \text{---} \end{array} \right]$ 75 100 150 200 1000 mm</p>		

High decorative surfaces → A 9
 Order example → A 21
 Heatsink as visual & decor-parts → A 10
 Drilling pattern for Solid State Relais → A 12

Heatsinks for Solid State Relay → A 11 – 12
 Special heatsink design → A 137 – 138
 Special profiles → A 140
 Technical introduction → A 2 – 8



Welded high performance heatsinks

- optimum fin geometry and fin quantity for free convection
- well suited for forced convection
- flat milled base (not SK 530, SK 531)
- * = welded joint (not SK 530, SK 531)
- length according customer's details
- customer specific versions and machining on request

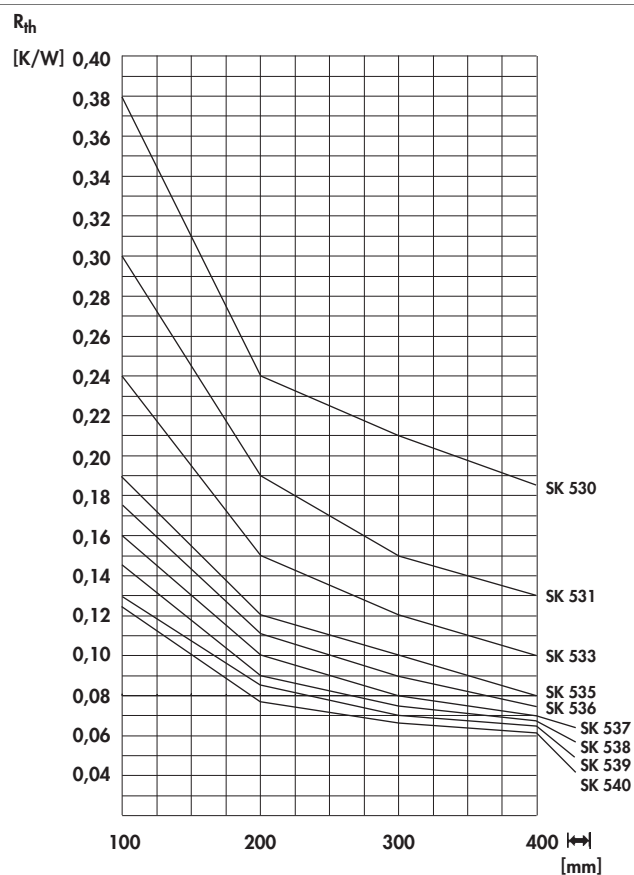
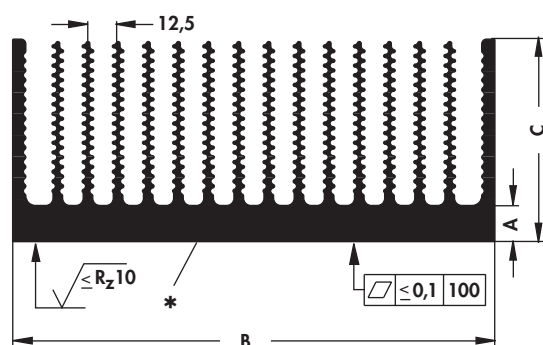

art. no.	number of fins	dim. [mm]		
		A	B	C
SK 530 ...	14	15 ±0.7	200 ±0.7	84 ±0.7
SK 531 ...	22	15 ±0.7	300 ±1	84 ±0.7
SK 533 ...	30	16 +0/-1.5	400 +0.6/-1.6	84 +0/-1.5
SK 535 ...	38	16 +0/-1.5	500 +0.6/-1.6	84 +0/-1.5
SK 536 ...	42	16 +0/-1.5	550 +0.6/-1.6	84 +0/-1.5
SK 537 ...	46	16 +0/-1.5	600 +0.6/-1.6	84 +0/-1.5
SK 538 ...	50	16 +0/-1.5	650 +0.6/-1.6	84 +0/-1.5
SK 539 ...	54	16 +0/-1.5	700 +0.6/-1.6	84 +0/-1.5
SK 540 ...	58	16 +0/-1.5	750 +0.6/-1.6	84 +0/-1.5
please indicate: ... \longleftrightarrow 200 300 400 500 600 mm				



High performance heatsinks with press-in fins

- other length according to customer's details
- customer specific versions and machining upon request

art. no.

SK 418 ...

please indicate: ... **100 150 200 1000 mm**

art. no.	number of fins	dim. [mm]	
		A	B
SK 158 ...	22	20	300 ±2
SK 159 ...	30	20	400 ±2
SK 160 ...	38	20	500 ±2.5
SK 161 ...	46	20	600 ±3
SK 162 ...	58	20	750 ±4

please indicate: ... **200 300 400 500 600 mm**

Standard extruded heatsinks

art. no. SK 09 ...	SK 09 37,5 TO 220 	SK 09 37,5 TO 220 I SK 09 50,0 TO 220 I 	SK 09 50 TO 220 	SK 09 20 TO 220
please indicate: ...	20 37.5 50 1000 mm			... ϕ (optional) K; TO 220
art. no. SK 145 ...	SK 145 20 TO 220 	SK 145 37,5 TO 220 	SK 145 50 TO 220 	SK 145 25 TO 220
please indicate: ...	20 25 37.5 50 1000 mm			... ϕ (optional) TO 220
art. no. SK 443 ...				
please indicate: ...	37.5 75 100 1000 mm			
art. no. SK 173 ...				
please indicate: ...	1000 mm			

Standard extruded heatsinks

<p>art. no.</p> <p>SK 59 ...</p>		
<p>please indicate: ... $\overline{\text{mm}}$ 37.5 50 75 100 1000 mm ... \varnothing (optional) TO 220</p>		
<p>art. no.</p> <p>SK 122 ...</p>		
<p>please indicate: ... $\overline{\text{mm}}$ 37.5 50 mm ... \varnothing (optional) TO 3; CB</p>		
<p>art. no.</p> <p>SK 107 ...</p>		
<p>please indicate: ... $\overline{\text{mm}}$ 50 75 100 1000 mm</p>		
<p>art. no.</p> <p>SK 181 ...</p>		
<p>please indicate: ... $\overline{\text{mm}}$ 50 75 100 1000 mm</p>		
<p>art. no.</p> <p>SK 181 94 C 3 x TO 220</p>		
<p>SK 181 94 C 3 x TO 220 retaining spring for transistor THF 409 TO 220 → A 115</p>		

Hole pattern
 Profiles for PCB components
 Heatsinks for PCB
 Profiles for PCB mounting

→ A 21
 → A 91
 → A 89
 → A 89 – 112

Screw mounted guide rails
 Thermal conductive material
 Heatsink-cooling aggregates
 Technical introduction

→ E 26 – 27
 → E 2 – 24
 → D 14
 → A 2 – 8

Standard extruded heatsinks

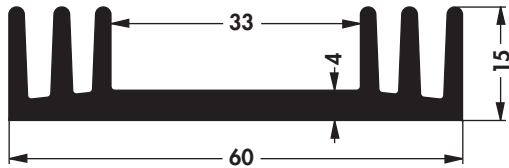
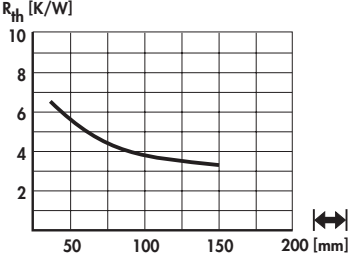
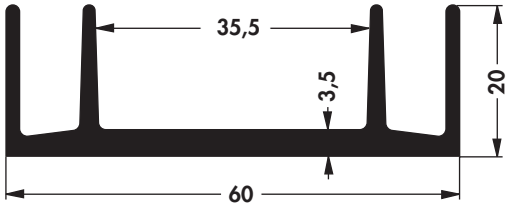
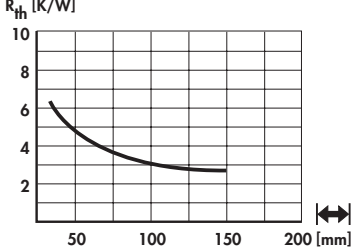
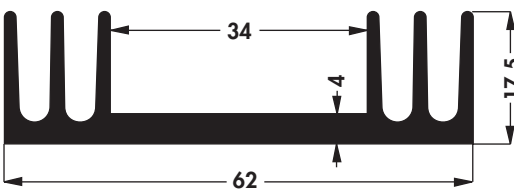
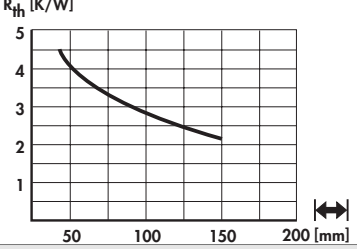
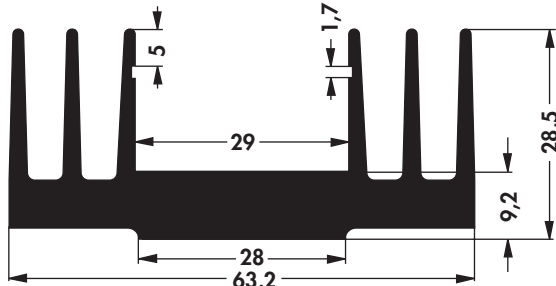
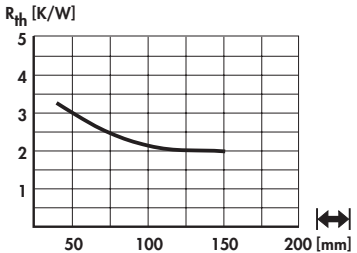
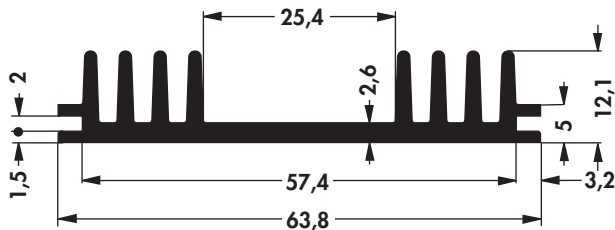
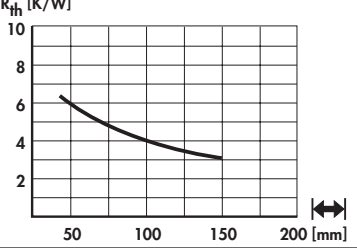
art. no. SK 78 ...		
please indicate: ... $\overline{\quad}$ 37.5 50 75 100 1000 mm ... \diamond (optional) TO 3; CB		
art. no. SK 51 ...		
please indicate: ... $\overline{\quad}$ 37.5 50 75 100 1000 mm ... \diamond (optional) TO 3; CB		
art. no. SK 165 ...		
please indicate: ... $\overline{\quad}$ 37.5 50 75 1000 mm ... \diamond (optional) TO 3; CB		
art. no. SK 25 ...		
SK 25 ... with slots for cover plates or PCBs		
please indicate: ... $\overline{\quad}$ 37.5 50 1000 mm		
art. no. SK 150 ...		
please indicate: ... $\overline{\quad}$ 1000 mm		

Standard extruded heatsinks

<p>art. no.</p> <p>SK 18 ...</p>		
<p>please indicate: ... $\overline{\text{mm}}$ 37.5 50 75 100 1000 mm ... \varnothing (optional) TO 3; CB</p>		
<p>art. no.</p> <p>SK 63 ...</p>		
<p>please indicate: ... $\overline{\text{mm}}$ 37.5 50 75 100 1000 mm ... \varnothing (optional) TO 3; CB</p>		
<p>art. no.</p> <p>SK 05 ...</p>		
<p>with slots for cover plates or PCBs</p>		
<p>please indicate: ... $\overline{\text{mm}}$ 50 75 100 1000 mm ... \varnothing (optional) TO 3; CB</p>		
<p>art. no.</p> <p>SK 402 ...</p>		
<p>please indicate: ... $\overline{\text{mm}}$ 100 mm ... \varnothing (optional) TO 3; CB</p>		
<p>art. no.</p> <p>SK 97 ...</p>		
<p>please indicate: ... $\overline{\text{mm}}$ 37.5 50 75 100 1000 mm ... \varnothing (optional) TO 3</p>		

Hole pattern
Profiles for PCB components
Heatsinks for PCB
Profiles for PCB mounting

→ A 21
→ A 91
→ A 89
→ A 89 – 112

Screw mounted guide rails
Thermal conductive material
Heatsink-cooling aggregates
Technical introduction

→ E 26 – 27
→ E 2 – 24
→ D 14
→ A 2 – 8

Standard extruded heatsinks

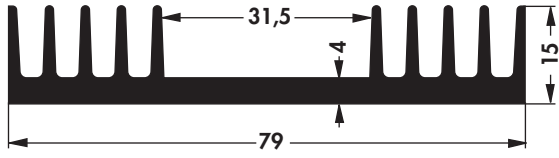
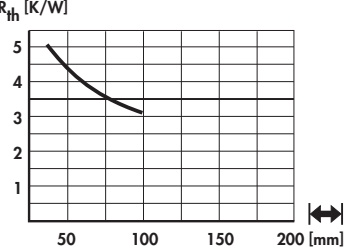
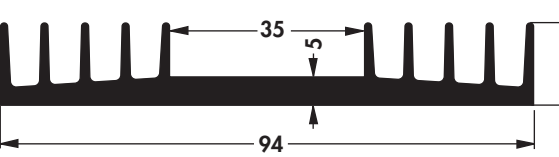
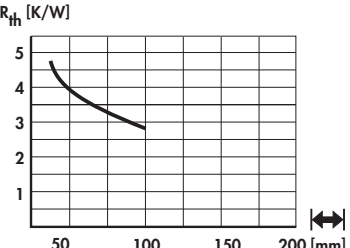
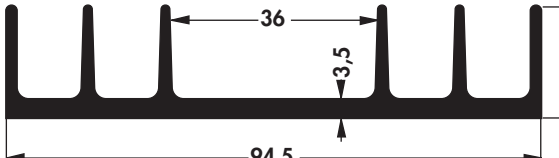
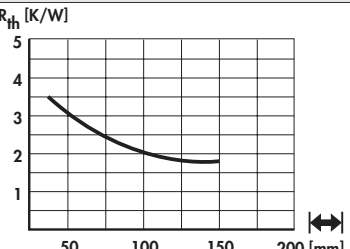
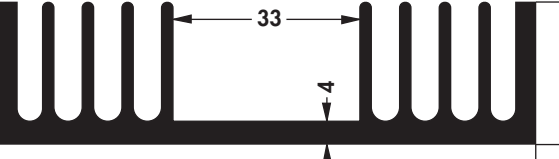
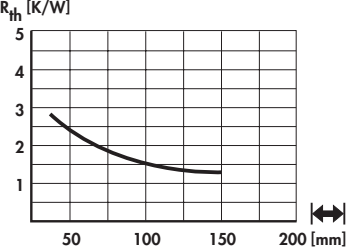
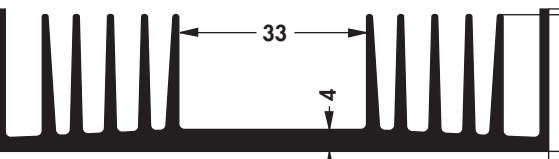
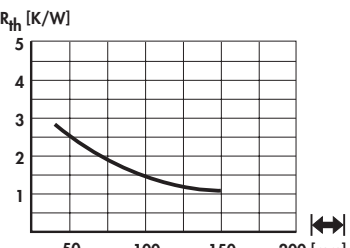
art. no. SK 45 ...		
please indicate: ... $\left[\begin{array}{c} \text{---} \\ \text{---} \\ \text{---} \end{array} \right]$ 37.5 50 75 100 1000 mm ... \diamond (optional) TO 3; CB		
art. no. SK 19 ...		
please indicate: ... $\left[\begin{array}{c} \text{---} \\ \text{---} \\ \text{---} \end{array} \right]$ 37.5 50 75 100 1000 mm ... \diamond (optional) TO 3; CB		
art. no. SK 28 ...		
please indicate: ... $\left[\begin{array}{c} \text{---} \\ \text{---} \\ \text{---} \end{array} \right]$ 37.5 50 75 1000 mm ... \diamond (optional) TO 3; CB		
art. no. SK 401 ...		
please indicate: ... $\left[\begin{array}{c} \text{---} \\ \text{---} \\ \text{---} \end{array} \right]$ 100 1000 mm ... \diamond (optional) TO 3; CB		
art. no. SK 72 ...		
please indicate: ... $\left[\begin{array}{c} \text{---} \\ \text{---} \\ \text{---} \end{array} \right]$ 37.5 50 75 100 1000 mm ... \diamond (optional) TO 3; CB		

Standard extruded heatsinks

<p>art. no.</p>		
<p>SK 04 ... with slots for cover plates or PCBs</p>		
<p>please indicate: ... $\left[\begin{array}{c} \text{---} \\ \text{---} \\ \text{---} \end{array} \right]$ 37.5 50 75 100 1000 mm ... ϕ (optional) SSR 1; SSR 2; TO 3; CB</p>		
<p>art. no.</p>		
<p>SK 403 ...</p> <p>please indicate: ... $\left[\begin{array}{c} \text{---} \\ \text{---} \\ \text{---} \end{array} \right]$ 1000 mm</p>		
<p>art. no.</p>		
<p>SK 73 ...</p> <p>please indicate: ... $\left[\begin{array}{c} \text{---} \\ \text{---} \\ \text{---} \end{array} \right]$ 50 75 1000 mm ... ϕ (optional) TO 3; CB</p>		
<p>art. no.</p>		
<p>SK 71 ...</p> <p>please indicate: ... $\left[\begin{array}{c} \text{---} \\ \text{---} \\ \text{---} \end{array} \right]$ 37.5 50 75 100 1000 mm ... ϕ (optional) TO 3</p>		
<p>art. no.</p>		
<p>SK 57 ... with slots for cover plates or PCBs</p>		
<p>please indicate: ... $\left[\begin{array}{c} \text{---} \\ \text{---} \\ \text{---} \end{array} \right]$ 37.5 75 100 1000 mm</p>		

Hole pattern
 Profiles for PCB components
 Heatsinks for PCB
 Profiles for PCB mounting

→ A 21
 → A 91
 → A 89
 → A 89 – 112

Screw mounted guide rails
 Thermal conductive material
 Heatsink-cooling aggregates
 Technical introduction

→ E 26 – 27
 → E 2 – 24
 → D 14
 → A 2 – 8



Standard extruded heatsinks

art. no. SK 197 ...		
please indicate: ... \square 37.5 1000 mm ... \diamond (optional) TO 3; CB		
art. no. SK 98 ...	<p>with slots for cover plates or PCBs</p>	
please indicate: ... \square 100 150 mm		
art. no. SK 404 ...		
please indicate: ... \square 50 75 1000 mm ... \diamond (optional) TO 3; CB		

A 65

Hole pattern
Profiles for PCB components
Heatsinks for PCB
Profiles for PCB mounting

→ A 21
→ A 91
→ A 89
→ A 89 - 112

Screw mounted guide rails
Thermal conductive material
Heatsink-cooling aggregates
Technical introduction

→ E 26 - 27
→ E 2 - 24
→ D 14
→ A 2 - 8

Standard extruded heatsinks

<p>art. no.</p> <p>SK 36 ...</p>		
<p>mounting parts IS 1, IS 2, IS 3 → E 49</p> <p>please indicate: ... [] 50 75 1000 mm ... ⌀ (optional) TO 3; CB</p>		
<p>art. no.</p> <p>SK 01 ...</p>		
<p>mounting parts IS 1, IS 2, IS 3 → E 49</p> <p>please indicate: ... [] 37.5 50 75 100 1000 mm ... ⌀ (optional) TO 3; CB</p>		
<p>art. no.</p> <p>SK 02 ...</p>		
<p>with slots for cover plates or PCBs; mounting parts IS 1, IS 2, IS 3 → E 49</p> <p>please indicate: ... [] 37.5 50 75 100 1000 mm ... ⌀ (optional) TO 3; CB</p>		
<p>art. no.</p> <p>SK 03 ...</p>		
<p>with slots for cover plates or PCBs; mounting parts IS 1, IS 2, IS 3 → E 49</p> <p>please indicate: ... [] 50 75 100 1000 mm ... ⌀ (optional) TO 3; CB</p>		

Thermal conductive material → E 2 - 5
 Mounting material for semiconductor. → E 44 - 48
 Mounting parts for heatsinks → E 49 - 50
 Distance sleeves for PCB's in HP grid → E 39

Order example → A 21
 Guide rails for PCBs → E 26 - 27
 Heatsink-cooling aggregates → D 14
 Technical introduction → A 2 - 8

Standard extruded heatsinks

art. no. SK 39 ...		
<p>with slots for cover plates or PCBs; mounting parts IS 1, IS 2, IS 3 → E 49</p> <p>please indicate: ... $\left[\begin{array}{c} \text{---} \\ \text{---} \end{array} \right]$ 75 100 1000 mm ... \diamond (optional) TO 3; CB</p>		
art. no. SK 30 ...		
<p>with slots for cover plates or PCBs; mounting parts IS 1, IS 2, IS 3 → E 49</p> <p>please indicate: ... $\left[\begin{array}{c} \text{---} \\ \text{---} \end{array} \right]$ 75 100 1000 mm ... \diamond (optional) TO 3; CB</p>		
art. no. SK 34 ...		
<p>with slots for cover plates or PCBs; mounting parts IS 1, IS 2, IS 3 → E 49</p> <p>please indicate: ... $\left[\begin{array}{c} \text{---} \\ \text{---} \end{array} \right]$ 50 75 100 1000 mm ... \diamond (optional) TO 3; CB</p>		
art. no. SK 14 ...		
<p>with slots for cover plates or PCBs; mounting parts IS 1, IS 2, IS 3 → E 49</p> <p>please indicate: ... $\left[\begin{array}{c} \text{---} \\ \text{---} \end{array} \right]$ 50 75 100 mm ... \diamond (optional) TO 3; CB</p>		

Standard extruded heatsinks

<p>art. no.</p> <p>SK 20 ...</p>		
<p>with slots for cover plates or PCBs; mounting parts IS 5, IS 8 → E 49</p> <p>please indicate: ... 37.5 75 100 1000 mm ... ∅ (optional) TO 3; CB</p>		
<p>art. no.</p> <p>SK 184 ...</p>		
<p>please indicate: ... 100 1000 mm</p>		
<p>art. no.</p> <p>SK 148 ...</p>		
<p>with slots for cover plates or PCBs</p> <p>please indicate: ... 37.5 100 1000 mm ... ∅ (optional) TO 3; CB</p>		
<p>art. no.</p> <p>SK 84 ...</p>		
<p>please indicate: ... 50 150 1000 mm ... ∅ (optional) TO 3</p>		

Standard extruded heatsinks

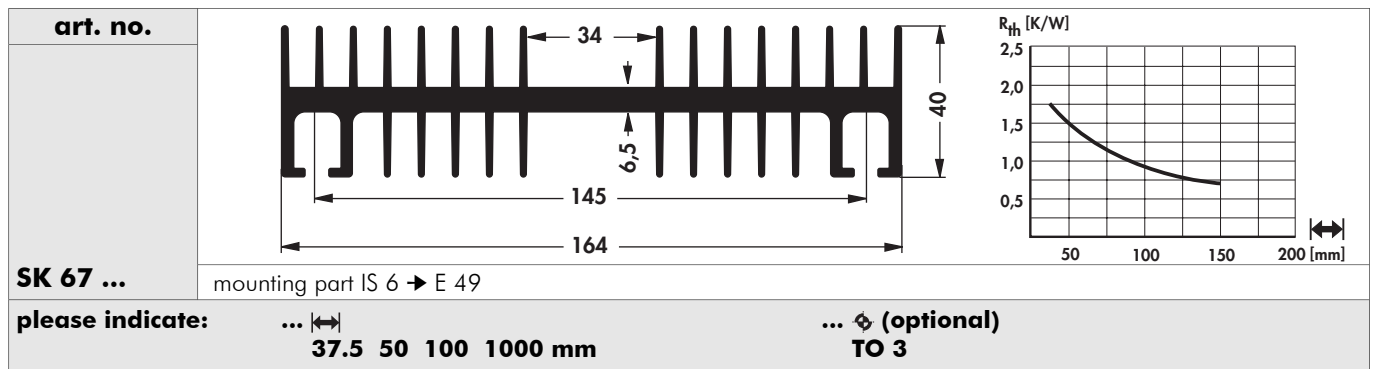

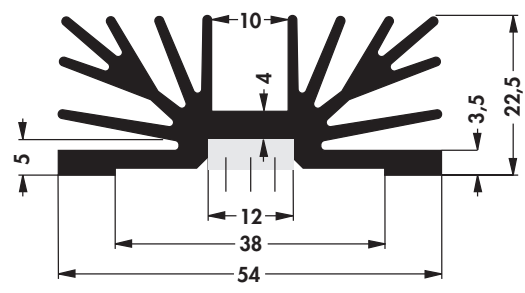
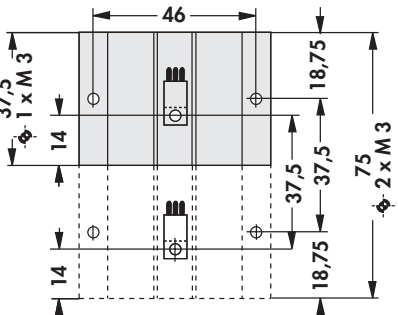
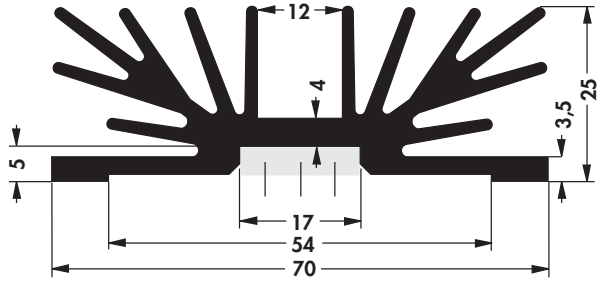
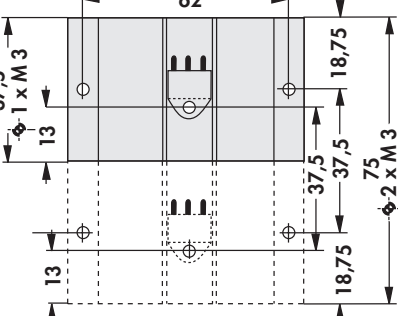
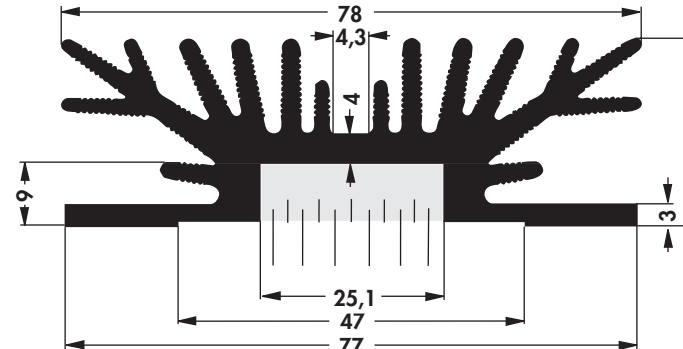
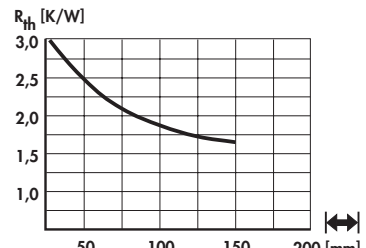
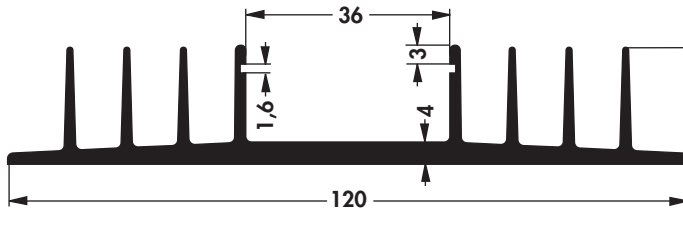
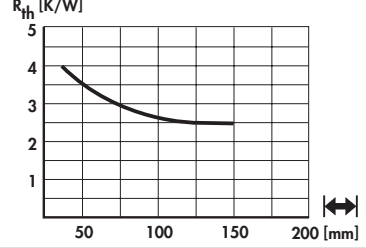

Standard extruded heatsinks

<p>art. no.</p>		
<p>SK 65 ...</p>	<p>for cases SOT 32</p>	
<p>please indicate: ... \square 37.5 75 mm ... \diamond (optional) 1xM3; 2xM3</p>		
<p>art. no.</p>		
<p>SK 64 ...</p>	<p>for cases TO 220, TOP 3</p>	
<p>please indicate: ... \square 37.5 75 mm ... \diamond (optional) 1xM3; 2xM3</p>		
<p>art. no.</p>		
<p>SK 419 ...</p>	<p>please indicate: ... \square 1000 mm</p>	
<p>art. no.</p>		
<p>SK 21 ...</p>	<p>with slots for cover plates or PCBs; mounting parts IS 1, IS 2, IS 3 → E 49</p>	
<p>please indicate: ... \square 37.5 1000 mm ... \diamond (optional) TO 3; CB</p>		

Mounting for TO 3 angle
Order example
Special heatsink design
Heatsinks for DC/DC converter

→ A 125 Insulating clamping parts
→ A 21 Mica wafers
→ A 137 - 138 Insulator sleeves
→ A 113 - 114 Technical introduction

→ E 45
→ E 19
→ E 52
→ A 2 - 8

A 70



Standard extruded heatsinks

art. no.		
SK 69 ...	mounting parts IS 1, IS 2, IS 3 → E 49	
please indicate:	... 50 75 100 1000 mm	... (optional) TO 3; CB
art. no.		
SK 74 ...		
please indicate:	... 37.5 100 1000 mm	... (optional) TO 3; CB
art. no.		
SK 124 ...		
please indicate:	... 50 100 150 1000 mm	... (optional) TO 3
art. no.		
SK 195 ...		
please indicate:	... 75 100 mm	... (optional) TO 3; CB



Standard extruded heatsinks

<p>art. no.</p> <p>SK 31 ...</p>		
<p>please indicate: ... $\left[\begin{array}{c} \text{---} \\ \text{---} \\ \text{---} \end{array} \right]$ 37.5 50 75 1000 mm ... \diamond (optional) TO 3; CB</p>		
<p>art. no.</p> <p>SK 07 ...</p>		
<p>please indicate: ... $\left[\begin{array}{c} \text{---} \\ \text{---} \\ \text{---} \end{array} \right]$ 37.5 50 75 1000 mm ... \diamond (optional) TO 3; CB</p>		
<p>art. no.</p> <p>SK 16 ...</p>		
<p>mountingpart IS 3 \rightarrow E 49</p>		
<p>please indicate: ... $\left[\begin{array}{c} \text{---} \\ \text{---} \\ \text{---} \end{array} \right]$ 75 1000 mm ... \diamond (optional) TO 3; CB</p>		
<p>art. no.</p> <p>SK 500 ...</p>		
<p>please indicate: ... $\left[\begin{array}{c} \text{---} \\ \text{---} \\ \text{---} \end{array} \right]$ 37.5 50 75 100 1000 mm</p>		

Special heatsink design
Mounting for TO 3 angle
Special profiles
Fin coolers

\rightarrow A 137 - 138 Hole pattern
 \rightarrow A 125 Profiles for lock-in fixing spring
 \rightarrow A 140 Extruded heatsinks
 \rightarrow A 129 Technical introduction

\rightarrow A 21
 \rightarrow A 84 - 88
 \rightarrow A 22 - 83
 \rightarrow A 2 - 8

Standard extruded heatsinks

art. no.		
SK 185 ...	extruded heatsink for PCB mounting → A 104	
please indicate:	... 37.5 50 1000 mm	... (optional) TO 3; CB
art. no.		
SK 48 ...	please indicate: ... 37.5 50 75 100 1000 mm	
art. no.		
SK 79 ...	with slots for cover plates or PCBs	
please indicate:	... 37.5 50 75 100 1000 mm	... (optional) TO 3; CB
art. no.		
SK 08 ...	with slots for cover plates or PCBs	
please indicate:	... 37.5 50 75 100 1000 mm	... (optional) TO 3; CB
art. no.		
SK 88 ...	with slots for cover plates or PCBs	
please indicate:	... 37.5 50 75 100 1000 mm	... (optional) TO 3

Standard extruded heatsinks

<p>art. no.</p> <p>SK 52 ...</p>		
<p>please indicate: ... $\overline{\quad}$... \diamond (optional)</p> <p>37.5 50 75 100 1000 mm 2xTO 3; 2xCB</p>		
<p>art. no.</p> <p>SK 60 ...</p>		
<p>please indicate: ... $\overline{\quad}$... \diamond (optional)</p> <p>50 75 100 1000 mm 2xTO 3; 2xCB</p>		
<p>art. no.</p> <p>SK 147 ...</p>		
<p>please indicate: ... $\overline{\quad}$... \diamond (optional)</p> <p>50 150 1000 mm 2xTO 3; 2xCB</p>		
<p>art. no.</p> <p>SK 80 ...</p>		
<p>please indicate: ... $\overline{\quad}$... \diamond (optional)</p> <p>75 100 1000 mm 2xTO 3; 2xCB</p>		
<p>art. no.</p> <p>SK 53 ...</p>		
<p>please indicate: ... $\overline{\quad}$... \diamond (optional)</p> <p>50 75 100 150 1000 mm 2xTO 3; 2xCB</p>		

Hole pattern
 Standard aluminium profiles
 Extruded heatsinks
 Thermal conductive material

→ A 21 Heatsink as visual & decor-parts
 → A 135 - 136 Assignment table
 → A 22 - 83 Kapton insulator washers
 → E 2 - 5 Technical introduction

→ A 10
 → A 18 - 20
 → E 16
 → A 2 - 8

Standard extruded heatsinks

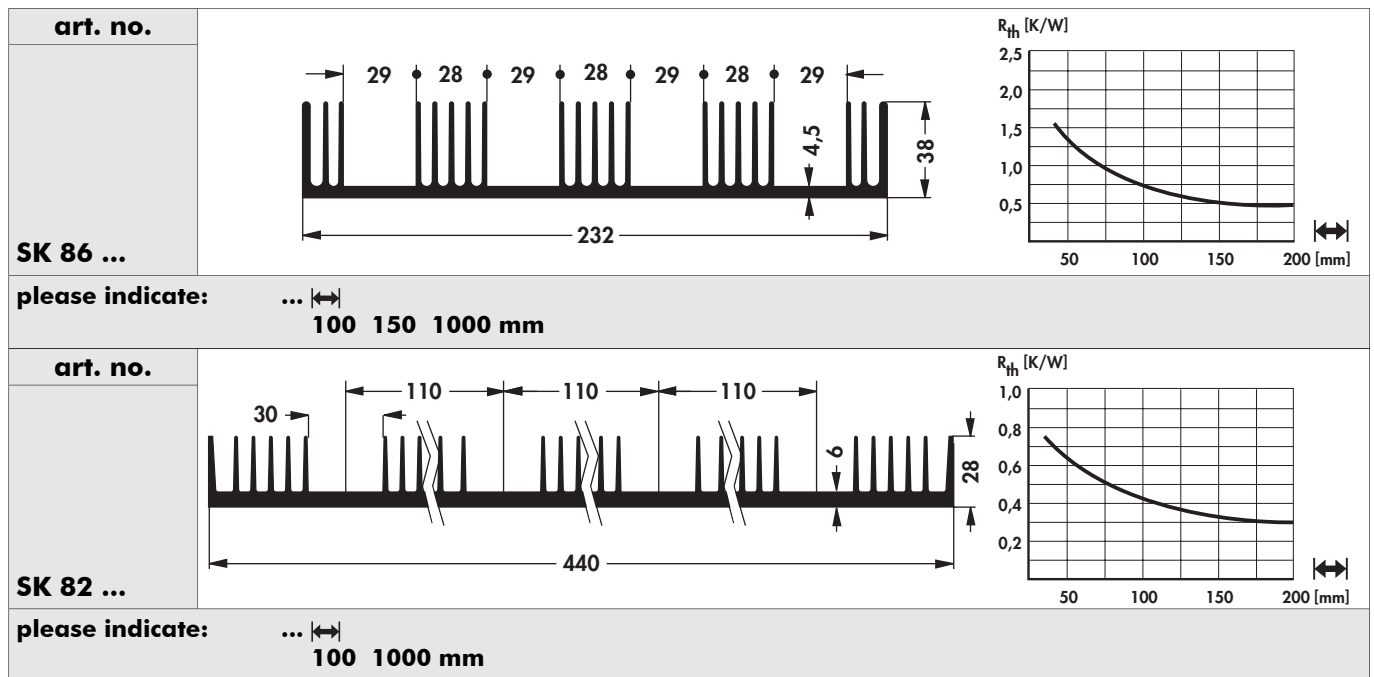

B

C

D

E

F

G

H

I

K

L

M

A 75

Hole pattern
Standard aluminium profiles
Extruded heatsinks
Thermal conductive material

→ A 21 Heatsink as visual & decor-parts
→ A 135 – 136 Assignment table
→ A 22 – 83 Kapton insulator washers
→ E 2 – 5 Technical introduction

→ A 10
→ A 18 – 20
→ E 16
→ A 2 – 8

Standard extruded heatsinks

<p>art. no.</p> <p>SK 596 ...</p>		
<p>please indicate: ... $\left[\begin{array}{c} \text{---} \\ \text{---} \end{array} \right]$ 37.5 50 75 100 1000 mm</p>		
<p>art. no.</p> <p>SK 544 ...</p>		
<p>please indicate: ... $\left[\begin{array}{c} \text{---} \\ \text{---} \end{array} \right]$ 50 75 100 1000 mm</p>		
<p>art. no.</p> <p>SK 32 ...</p>		
<p>please indicate: ... $\left[\begin{array}{c} \text{---} \\ \text{---} \end{array} \right]$ 37.5 50 75 100 1000 mm</p>		
<p>art. no.</p> <p>SK 187 ...</p>		
<p>please indicate: ... $\left[\begin{array}{c} \text{---} \\ \text{---} \end{array} \right]$ 75 1000 mm ... $\left[\begin{array}{c} \text{---} \\ \text{---} \end{array} \right]$ (optional) SSR 3</p>		

Hole pattern
 Standard aluminium profiles
 Extruded heatsinks
 Thermal conductive material

→ A 21 heatsinks for Solid State Relais
 → A 135 - 136 Assignment table
 → A 22 - 83 Kapton insulator washers
 → E 2 - 5 Technical introduction

→ A 11 - 12
 → A 18 - 20
 → E 16
 → A 2 - 8

Standard extruded heatsinks

art. no. SK 140 ...		
please indicate: ... 1000 mm		
art. no. SK 556 ...		
please indicate: ... 75 100 150 1000 mm		
art. no. SK 15 ...		
please indicate: ... 75 1000 mm		
art. no. SK 89 ...		
please indicate: ... 100 150 1000 mm		
with slots for cover plates or PCBs		... (optional) SSR 1; SSR 2

Standard extruded heatsinks

<p>art. no.</p> <p>SK 163 ...</p>		
<p>please indicate: ... $\left[\begin{array}{ c } \hline \text{---} \\ \hline \end{array} \right]$ 100 150 1000 mm</p>		
<p>art. no.</p> <p>SK 176 ...</p>		
<p>please indicate: ... $\left[\begin{array}{ c } \hline \text{---} \\ \hline \end{array} \right]$ 75 100 150 1000 mm ... $\left[\begin{array}{ c } \hline \text{---} \\ \hline \end{array} \right]$ (optional) SSR 2</p>		

Hole pattern
 Standard aluminium profiles
 Extruded heatsinks
 Thermal conductive material

→ A 21 heatsinks for Solid State Relais
 → A 135 - 136 Assignment table
 → A 22 - 83 Kapton insulator washers
 → E 2 - 5 Technical introduction

→ A 11 - 12
 → A 18 - 20
 → E 16
 → A 2 - 8

Standard extruded heatsinks

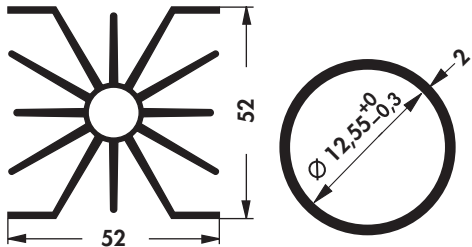
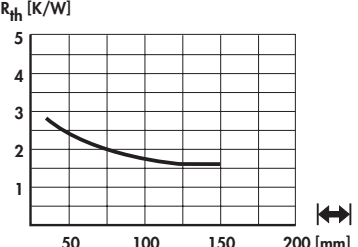
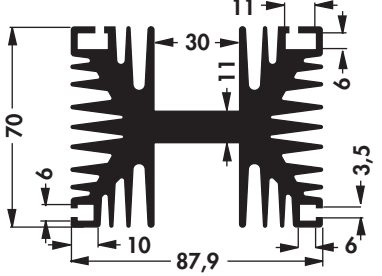
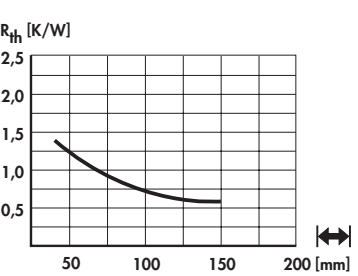
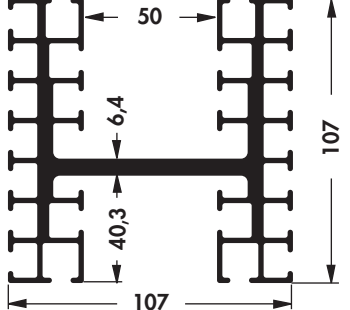
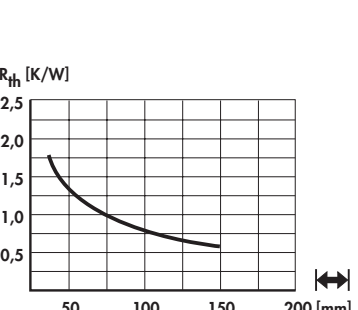
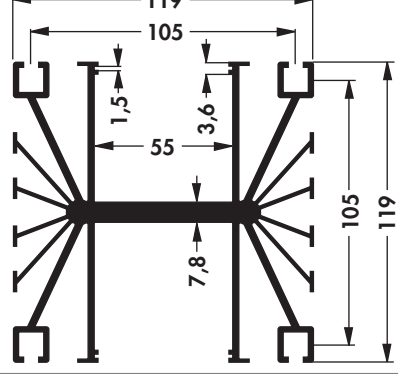
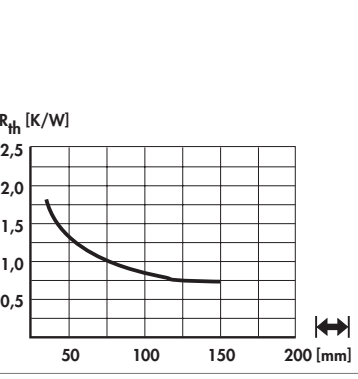
art. no. SK 11 ...		
<p>threads, through holes and fixing according to your demand; mounting parts IS 1, IS 2, IS 3 → E 49</p> <p>please indicate: ... $\left[\begin{array}{c} \text{---} \\ \text{---} \end{array} \right]$ 1000 mm</p>		
art. no. SK 83 ...		
<p>please indicate: ... $\left[\begin{array}{c} \text{---} \\ \text{---} \end{array} \right]$ 100 1000 mm</p>		
art. no. SK 06 ...		
<p>mounting part IS 4 → E 49</p> <p>please indicate: ... $\left[\begin{array}{c} \text{---} \\ \text{---} \end{array} \right]$ 75 1000 mm</p>		
art. no. SK 23 ...		
<p>with slots for cover plates or PCBs; equipped with fan and endplates = LA 4 → D 14</p> <p>please indicate: ... $\left[\begin{array}{c} \text{---} \\ \text{---} \end{array} \right]$ 75 mm</p>		

A 79

Profiles for PCB components
High capacity heatsinks
Mounting for TO 3 angle
Heatsinks for PCB

→ A 91
→ A 57 - 58
→ A 125
→ A 89 - 112

heatsinks for lock-in retaining spring → A 85 - 88
Heatsink-cooling aggregates → D 14
Special heatsink design → A 137 - 138
Technical introduction → A 2 - 8

Standard extruded heatsinks

art. no.

SK 110 ...

please indicate: ... $\left[\begin{array}{c} \text{---} \\ \text{---} \\ \text{---} \end{array} \right]$
150 200 1000 mm

art. no.

SK 109 ...

with slots for cover plates or PCBs

please indicate: ... $\left[\begin{array}{c} \text{---} \\ \text{---} \\ \text{---} \end{array} \right]$
100 150 200 1000 mm

art. no.

SK 108 ...

with slots for cover plates or PCBs

please indicate: ... $\left[\begin{array}{c} \text{---} \\ \text{---} \\ \text{---} \end{array} \right]$
100 1000 mm

- | | | | |
|-----------------------------|--------------|--|---------------|
| Profiles for PCB components | → A 91 | heatsinks for lock-in retaining spring | → A 85 – 88 |
| High capacity heatsinks | → A 57 – 58 | Heatsink-cooling aggregates | → D 14 |
| Mounting for TO 3 angle | → A 125 | Special heatsink design | → A 137 – 138 |
| Heatsinks for PCB | → A 89 – 112 | Technical introduction | → A 2 – 8 |

A 80

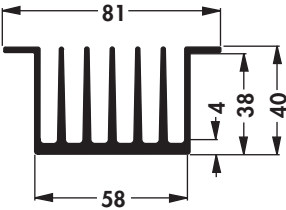
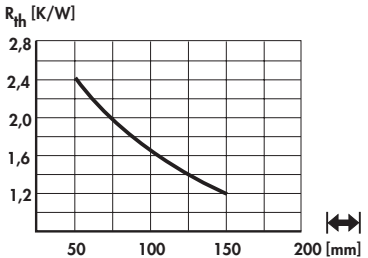
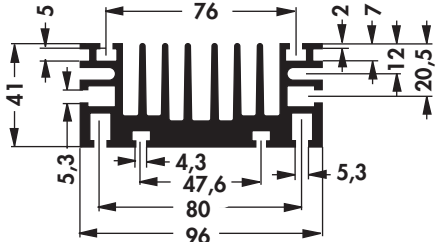
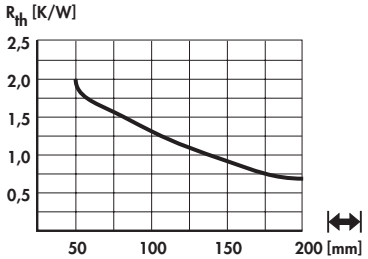
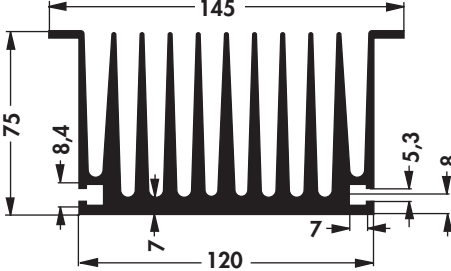
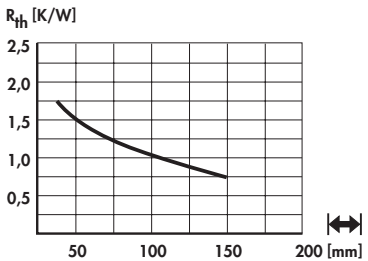
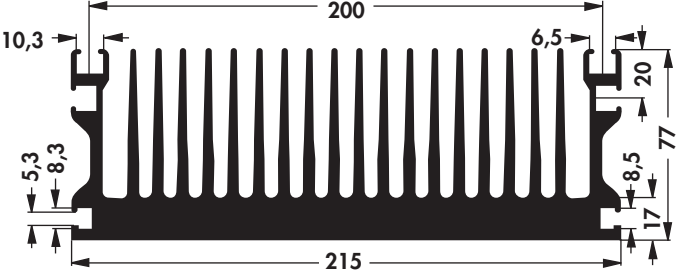
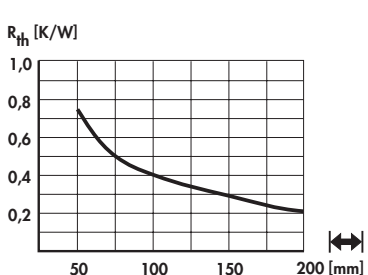

Standard extruded heatsinks

art. no. SK 111 ...		
please indicate: ... \square 75 100 1000 mm ... \diamond (optional) SSR 1; SSR 3		
art. no. SK 172 ...		
please indicate: ... \square 50 75 100 150 1000 mm ... \diamond (optional) SSR 1; SSR 4		
art. no. SK 194 ...		
please indicate: ... \square 75 1000 mm ... \diamond (optional) SSR 2		
art. no. SK 435 ...		
please indicate: ... \square 150 200 1000 mm		

Standard extruded heatsinks

art. no.

SK 432 ... with slots for cover plates or PCBs

please indicate: ... 100 1000 mm

art. no.

SK 40 ...

please indicate: ... 100 1000 mm

art. no.

SK 61 ... with slots for cover plates or PCBs; cooling case → M 29

please indicate: ... 75 100 150 1000 mm

art. no.

SK 144 ...

please indicate: ... 1000 mm

High capacity heatsinks
 Heatsinks for DC/DC converter
 Heatsinks for lock-in retaining spring
 Heatsink profile-overview







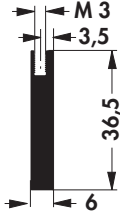
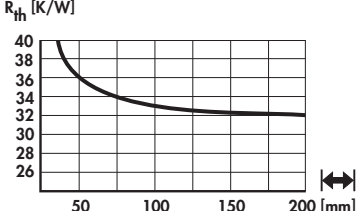

→ A 57 – 58
 → A 113 – 114
 → A 85 – 88
 → A 13 – 17

Extruded heatsinks
 Die-cast heatsinks
 High decorative surfaces
 Technical introduction

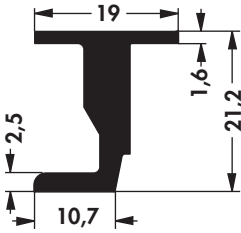
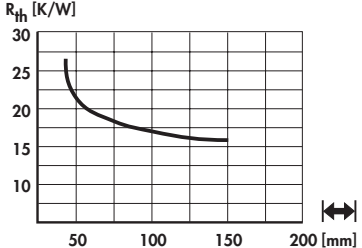

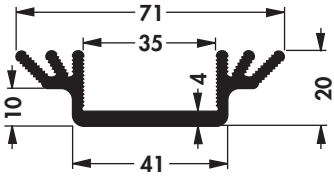
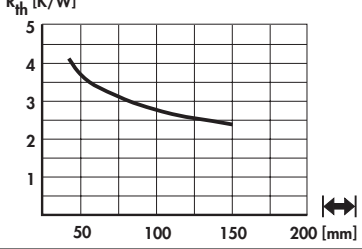

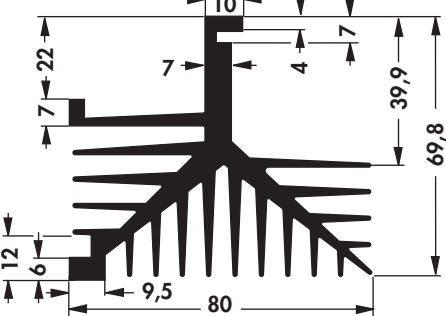
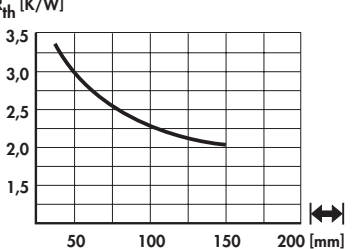



→ A 22 – 83
 → A 125
 → A 9
 → A 2 – 8

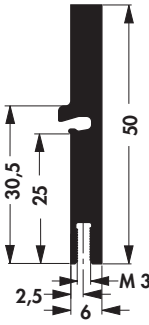
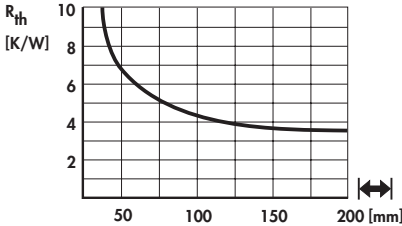

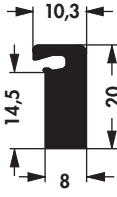
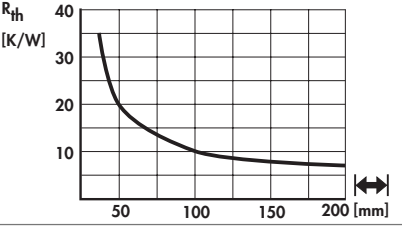
Standard extruded heatsinks

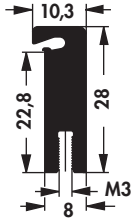
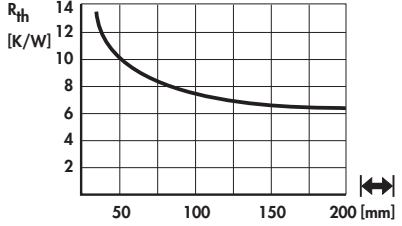
art. no. SK 494 ...		
please indicate: ...  25 37.5 50 75 100 1000 mm		
art. no. SK 153 ...		
please indicate: ...  50 mm		
art. no. SK 55 ...		
please indicate: ...  37.5 1000 mm ...  (optional) TO 3; CB		
art. no. SK 175 ...		
please indicate: ...  50 1000 mm		

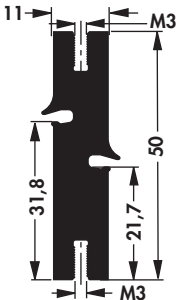
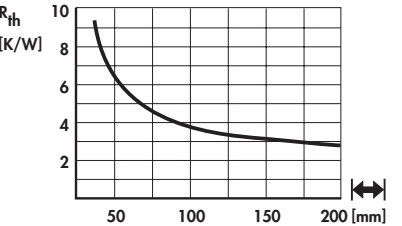

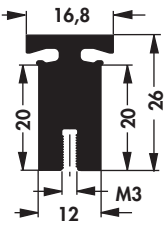
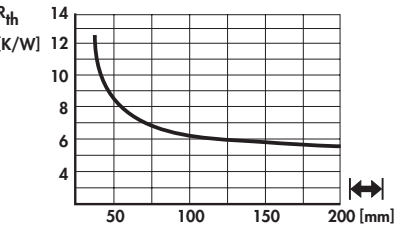

Extruded heatsinks for lock-in retaining spring

<p>art. no.</p> <p>SK 575 ...</p>			
<p>please indicate: ... $\left[\text{mm} \right]$ 25 37.5 50 75 84 100 1000 mm</p>			
<p>art. no.</p> <p>SK 512 ...</p>			
<p>please indicate: ... $\left[\text{mm} \right]$ 25 50 100 1000 mm</p>			
<p>art. no.</p> <p>SK 480 ...</p>			
<p>please indicate: ... $\left[\text{mm} \right]$ 25 37.5 50 75 84 100 1000 mm</p>			
<p>art. no.</p> <p>SK 490 ...</p>			
<p>please indicate: ... $\left[\text{mm} \right]$ 37.5 50 75 84 100 1000 mm</p>			
<p>art. no.</p> <p>SK 492 ...</p>			
<p>please indicate: ... $\left[\text{mm} \right]$ 25 37.5 50 75 84 100 1000 mm</p>			

please note: profile threads → A 5

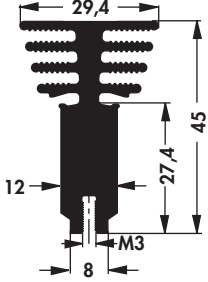
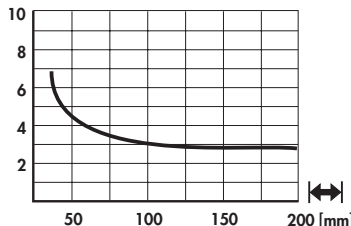

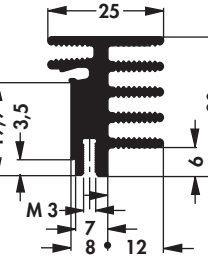
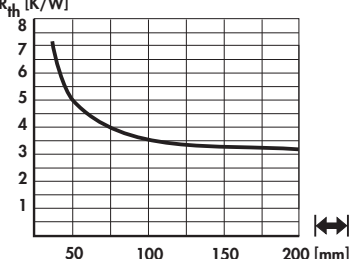
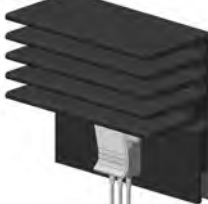
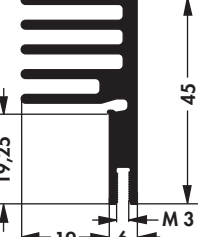
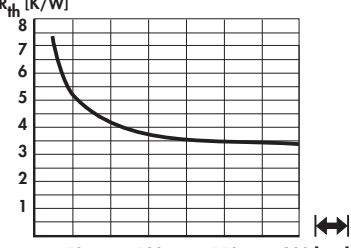

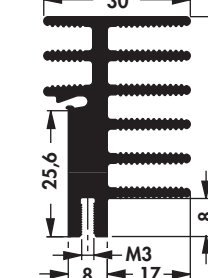
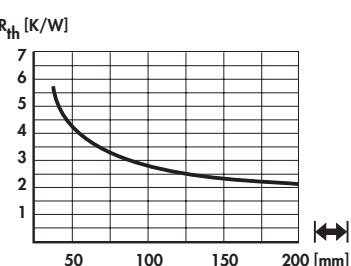
- | | |
|--|-------------------------------------|
| Mounting parts for heatsinks → E 49 – 50 | Heatsinks for PCB → A 89 |
| Insulating caps → E 51 | Profiles for PCB components → A 91 |
| Mounting pads → E 46 | Heatsinks with threaded rail → A 93 |
| Lock-in retaining spring for transistors → A 119 – 121 | Technical introduction → A 2 – 8 |

Extruded heatsinks for lock-in retaining spring

art. no. SK 489 ...			
please indicate: ... $\left[\begin{array}{c} \text{---} \\ \text{---} \end{array} \right]$ 25 37.5 50 75 84 100 1000 mm			
art. no. SK 573 ...			
please indicate: ... $\left[\begin{array}{c} \text{---} \\ \text{---} \end{array} \right]$ 25 37.5 50 75 84 100 1000 mm			
art. no. SK 576 ...			
please indicate: ... $\left[\begin{array}{c} \text{---} \\ \text{---} \end{array} \right]$ 25 37.5 50 75 84 100 1000 mm			
art. no. SK 481 ...			
please indicate: ... $\left[\begin{array}{c} \text{---} \\ \text{---} \end{array} \right]$ 25 37.5 50 75 84 100 1000 mm			

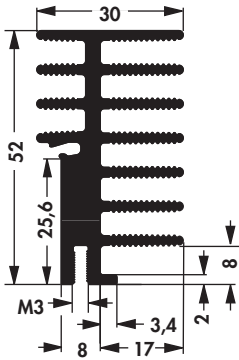
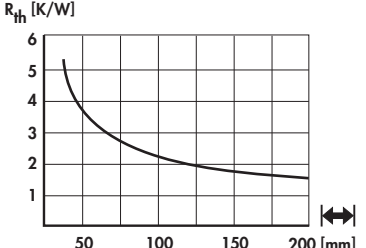
please note: profile threads → A 5

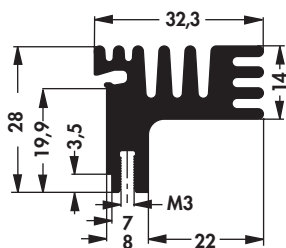
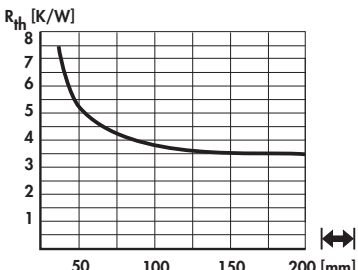
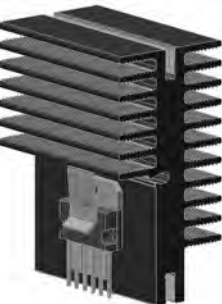
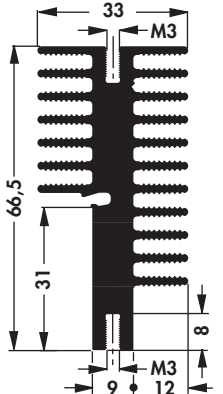
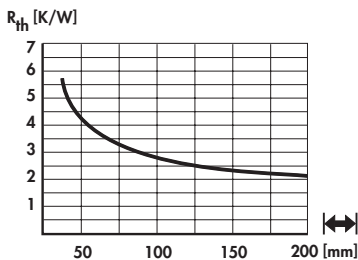

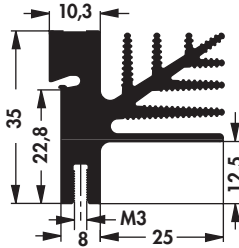
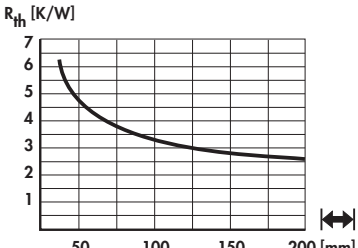



Extruded heatsinks for lock-in retaining spring

<p>art. no.</p> <p>SK 514 ...</p>			
<p>please indicate: ... $\left[\begin{array}{c} \text{---} \\ \text{---} \end{array} \right]$ 25 37.5 50 75 100 1000 mm</p>			
<p>art. no.</p> <p>SK 574 ...</p>			
<p>please indicate: ... $\left[\begin{array}{c} \text{---} \\ \text{---} \end{array} \right]$ 25 37.5 50 75 84 100 1000 mm</p>			
<p>art. no.</p> <p>SK 589 ...</p>			
<p>please indicate: ... $\left[\begin{array}{c} \text{---} \\ \text{---} \end{array} \right]$ 25 37.5 50 75 84 100 1000 mm</p>			
<p>art. no.</p> <p>SK 482 ...</p>			
<p>please indicate: ... $\left[\begin{array}{c} \text{---} \\ \text{---} \end{array} \right]$ 25 37.5 50 75 84 100 1000 mm</p>			

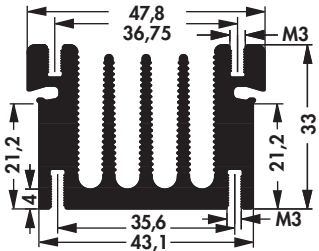
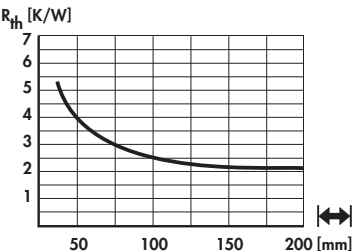
please note: profile threads → A 5

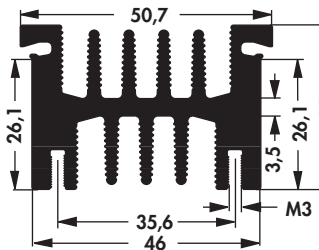
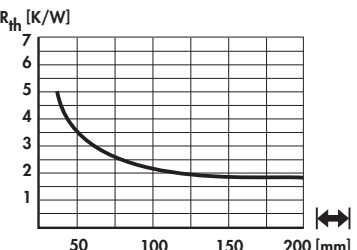

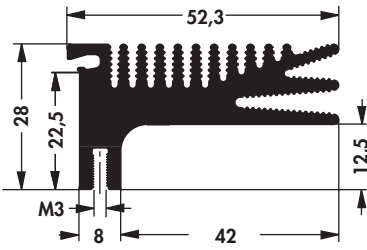
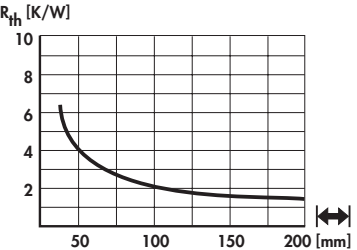
- | | |
|--|-------------------------------------|
| Mounting parts for heatsinks → E 49 – 50 | Heatsinks for PCB → A 89 |
| Insulating caps → E 51 | Profiles for PCB components → A 91 |
| Mounting pads → E 46 | Heatsinks with threaded rail → A 93 |
| Lock-in retaining spring for transistors → A 119 – 121 | Technical introduction → A 2 – 8 |

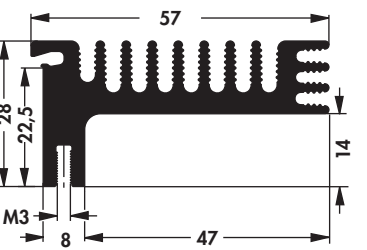
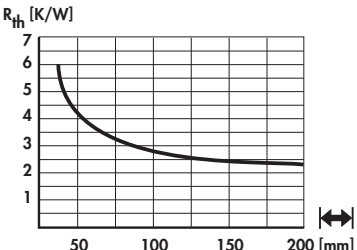
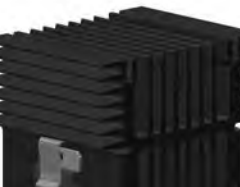
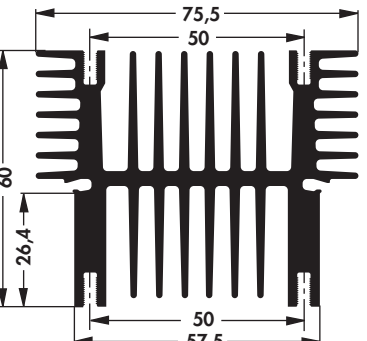
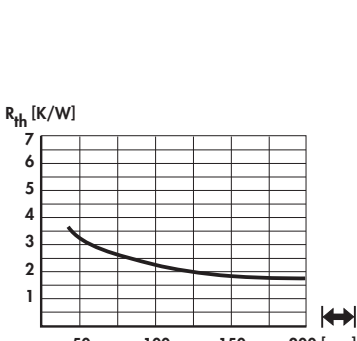
Extruded heatsinks for lock-in retaining spring

art. no. SK 495 ...			
please indicate: ... $\left[\begin{array}{c} \text{---} \\ \text{---} \end{array} \right]$ 25 37.5 50 75 100 1000 mm			
art. no. SK 499 ...			
please indicate: ... $\left[\begin{array}{c} \text{---} \\ \text{---} \end{array} \right]$ 25 37.5 50 75 100 1000 mm			
art. no. SK 487 ...			
please indicate: ... $\left[\begin{array}{c} \text{---} \\ \text{---} \end{array} \right]$ 25 37.5 50 75 84 100 1000 mm			
art. no. SK 483 ...			
please indicate: ... $\left[\begin{array}{c} \text{---} \\ \text{---} \end{array} \right]$ 25 37.5 50 75 84 100 1000 mm			
art. no. SK 593 ...			
please indicate: ... $\left[\begin{array}{c} \text{---} \\ \text{---} \end{array} \right]$ 25 37.5 50 75 84 100 1000 mm			

please note: profile threads → A 5

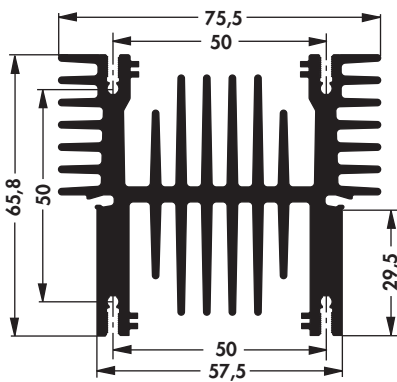
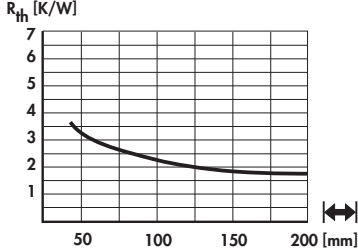
Extruded heatsinks for lock-in retaining spring

art. no.			
SK 617 ...			
please indicate:	... 		
	25 37.5 50 75 84 94 100 1000 mm		

please note: profile threads → A 5

Screw-in solder pin ELS 3

- screw in solder pin made of brass
- easy mounting
- secure hold
- surface coating suitable for soldering
- suitable for all heatsinks with M3 profile thread
- position in the threaded channel as required
- specific designs upon customer's request

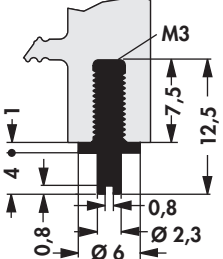
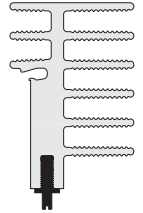



art. no.			
ELS 3			

Mounting parts for heatsinks	→ E 49 – 50	Heatsinks for PCB	→ A 89
Insulating caps	→ E 51	Profiles for PCB components	→ A 91
Mounting pads	→ E 46	Heatsinks with threaded rail	→ A 93
Lock-in retaining spring for transistors	→ A 119 – 121	Technical introduction	→ A 2 – 8

Extruded heatsinks for PCB mounting

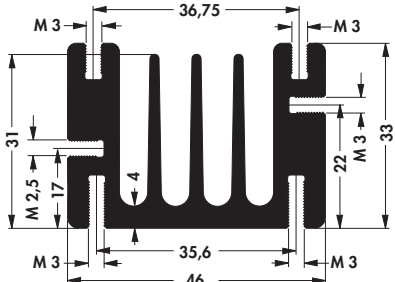
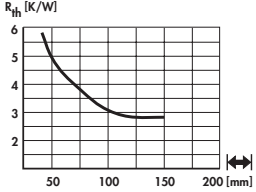
Heatsinks for printed circuit boards

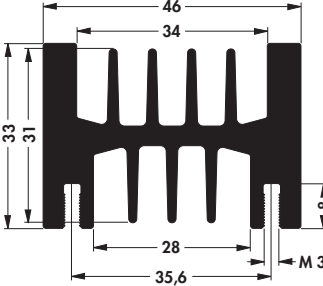
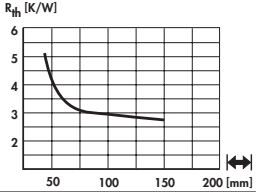
- matching cylindrical screws according to DIN 84 with zinc coated surface
- M 3 thread diameter: 2.90 ... 2.94 mm (**art. no.: SZ M 3 x 8**)
- screw-in solder pin M 3 (**art. no.: ELS 3**)

art. no. SK 68 ...			
art. no. SK 112 ...			
please indicate: ...  37.5 50 75 94 100 1000 mm			

please note: profile threads → A 5

A 89







Lock-in retaining spring for transistors → A 119 – 121
 Profiles for PCB components → A 91
 Vibration dampers → E 41
 Heatsinks with threaded rail → A 93

Miniature distance sleeves → E 34
 Thermal conductive glue → E 23 – 24
 Thermal conductive paste → E 21 – 22
 Technical introduction → A 2 – 8

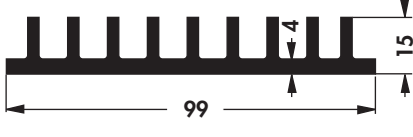
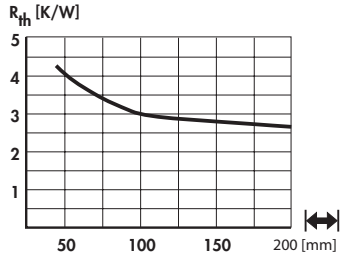
Extruded heatsinks for PCB mounting

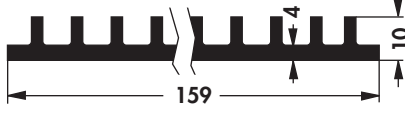
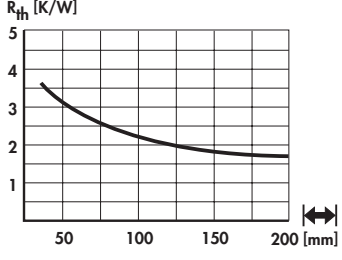
Heatsinks for printed circuit boards

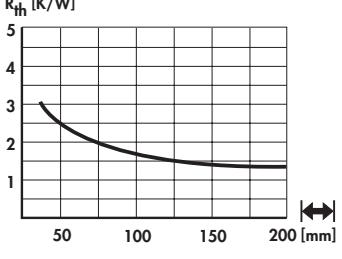
– the heatsinks SK 414, SK 105, SK 44 and SK 415 are especially suitable for printed circuit board heatsinks for 19" plug in units

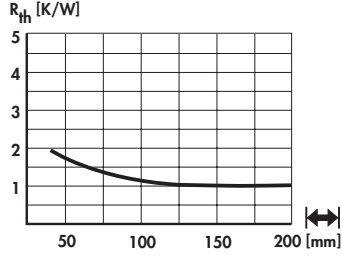
<p>art. no.</p> <p>SK 414 ...</p>			
<p>please indicate: ... $\left[\begin{array}{c} \text{---} \\ \text{---} \end{array} \right]$ 100 233.4 1000 mm</p>			
<p>art. no.</p> <p>SK 105 ...</p>			
<p>please indicate: ... $\left[\begin{array}{c} \text{---} \\ \text{---} \end{array} \right]$ 37.5 50 75 100 150 200 233.4 1000 mm</p>			
<p>art. no.</p> <p>SK 44 ...</p>			
<p>please indicate: ... $\left[\begin{array}{c} \text{---} \\ \text{---} \end{array} \right]$ 50 75 100 150 200 233.4 1000 mm</p>			
<p>art. no.</p> <p>SK 415 ...</p>			
<p>please indicate: ... $\left[\begin{array}{c} \text{---} \\ \text{---} \end{array} \right]$ 37.5 100 150 1000 mm</p>			

Extruded heatsinks for PCB mounting

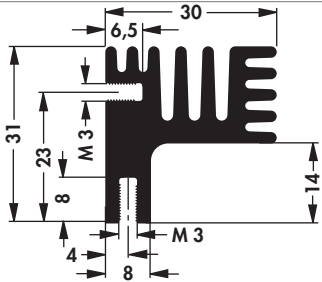
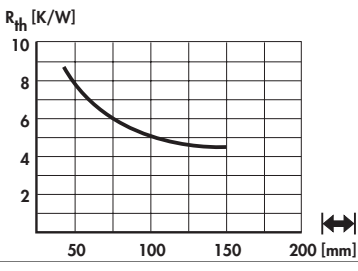
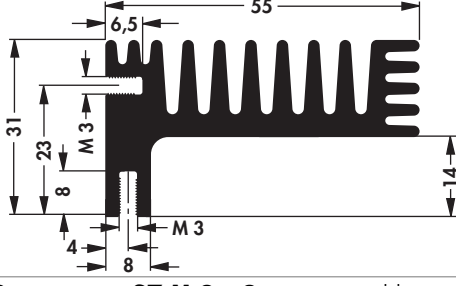
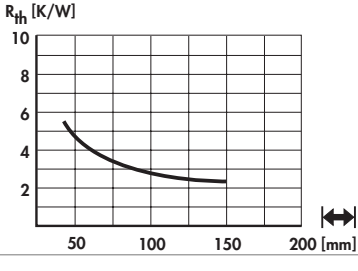
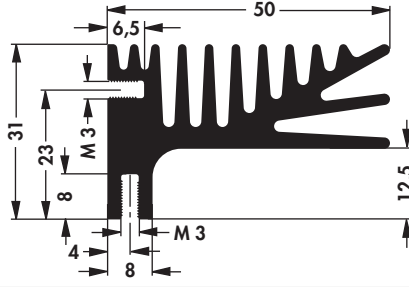
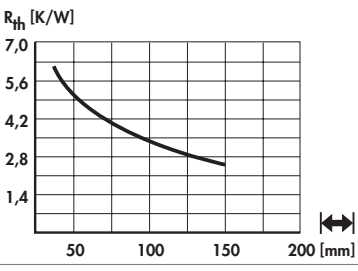
<p>art. no.</p> <p>SK 609 ...</p>	 <p>screws M 3: art. no.: SZ M 3 x 8; screw-in solder pin: art. no.: ELS 3</p>	
<p>art. no.</p> <p>SK 610 ...</p>	 <p>screws M 3: art. no.: SZ M 3 x 8; screw-in solder pin: art. no.: ELS 3</p>	
<p>art. no.</p> <p>SK 611 ...</p> <p>please indicate: ... \longleftrightarrow 50 84 94 1000 mm</p>	 <p>screws M 3: art. no.: SZ M 3 x 8; screw-in solder pin: art. no.: ELS 3</p>	

please note: profile pressed threads → A 5

- | | |
|--|---|
| Lock-in retaining spring for transistors → A 119 – 121 | Thermal conductive material → E 2 – 23 |
| Heatsink profile overview → A 13 – 17 | Profiles for lock-in fixing spring → A 84 – 88 |
| Heatsinks for PCB → A 89 | Retaining springs for transistors → A 115 – 117 |
| Heatsinks with threaded rail → A 93 | Technical introduction → A 2 – 8 |

Extruded heatsinks for PCB mounting

Heatsink for PCB with threaded rail

- transistor mounting onto the heatsink using a slide-in rail with M 3 thread
- easy positioning using a grid 6.35mm
- other rail grids upon request
- suitable for TO 220, TO 218, TO 247 and similar
- suitable screws M 3 (**art. no.: SZ M 3 x 8**)
- screw-in solder pin M 3 (**art. no.: ELS 3**)
- specific versions upon customer's request

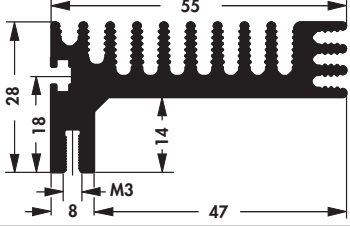
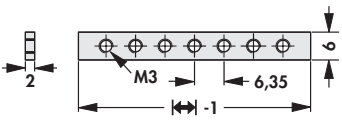
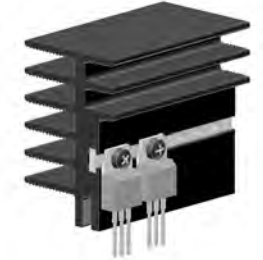
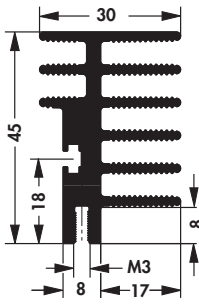
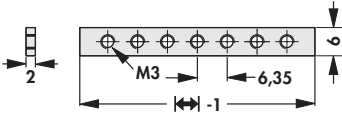
				
art. no.	l [mm]	R _{th} [K/W]	⌀	version
SK 517 50 GS	50	5.0	TO 220	with threaded rail
SK 517 75 GS	75	3.9	TO 220	with threaded rail
SK 517 84 GS	84	3.6	TO 220	with threaded rail
SK 517 50	50	5.0	—	without threaded rail
SK 517 75	75	3.9	—	without threaded rail
SK 517 84	84	3.6	—	without threaded rail
				
art. no.	l [mm]	R _{th} [K/W]	⌀	version
SK 518 50 GS	50	4.3	TO 220	with threaded rail
SK 518 75 GS	75	3.3	TO 220	with threaded rail
SK 518 84 GS	84	3.0	TO 220	with threaded rail
SK 518 50	50	4.3	—	without threaded rail
SK 518 75	75	3.3	—	without threaded rail
SK 518 84	84	3.0	—	without threaded rail

please note: profile threads → A 5

surface:	black anodised
-----------------	----------------

Extruded heatsinks for PCB mounting

Attachable heatsinks for transistors

- compact heatsink in transistor dimensions
- for horizontal and vertical transistors
- can be screwed or glued
- specific versions upon customer's request

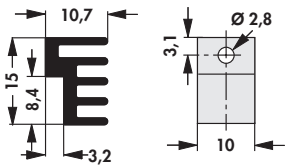
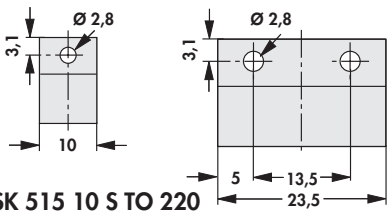
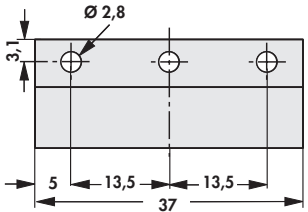
art. no.	W [mm]	R _{th} [K/W]	⌀	version
SK 515 10 S TO 220	10.0	30.0	TO 220	for screw fastening M2.5
SK 515 23,5 S 2 x TO 220	23.5	27.5	2xTO 220	for screw fastening M2.5
SK 515 37 S 3 x TO 220	37.0	26.1	3xTO 220	for screw fastening M2.5
SK 515 10 TO 220	10.0	30.0	—	without screw fastening
SK 515 23,5 TO 220	23.5	27.5	—	without screw fastening
SK 515 37 TO 220	37.0	26.1	—	without screw fastening

art. no.	W [mm]	R _{th} [K/W]	⌀	version
SK 516 15 S TO 218	15	28.4	TO 218	for screw fastening M3
SK 516 33 S 2 x TO 218	33	26.9	2xTO 218	for screw fastening M3
SK 516 15 TO 218	15	28.4	—	without screw fastening

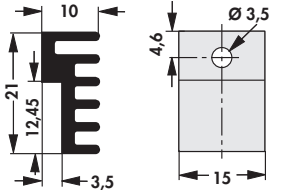
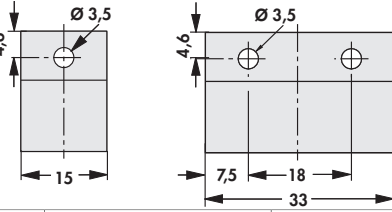
surface: black anodised

Attachable extruded heatsinks for transistors with thin bottom plate (0.5 mm)

art. no.	W [mm]	R _{th} [K/W]	⌀	version
SK 515 05 10 S	10.0	30.0	TO 220	for screw fastening M2.5
SK 515 05 23,5 S 2	23.5	27.5	2xTO 220	for screw fastening M2.5
SK 515 05 37 S 3	37.0	26.1	3xTO 220	for screw fastening M2.5
SK 515 05 10	10.0	30.0	—	without screw fastening
SK 515 05 23,5	23.5	27.5	—	without screw fastening
SK 515 05 37	37.0	26.1	—	without screw fastening

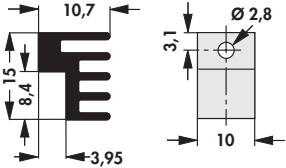
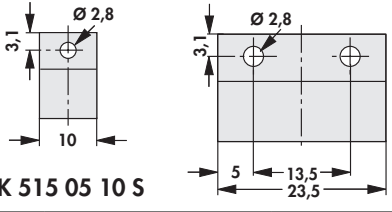
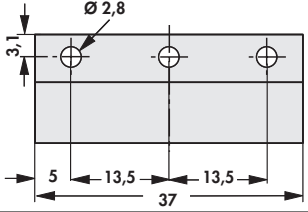
surface: black anodised

Profiles for lock-in fixing spring

→ A 84 – 88

Mica wafers

→ E 19

Assignment table

→ A 18 – 20

Kapton insulator washers

→ E 16

Thermal conductive material

→ E 2 – 5

Thermal conductive paste

→ E 21

Lock-in retaining spring for transistors

→ A 119 – 121

Technical introduction

→ A 2 – 8

Extruded heatsinks for PCB mounting

Attachable heatsinks for transistors



- extruded heatsink with intergrated spring locking function
- simple assembly by pushing the heatsink onto the transistor
- optimum heat transfer between component and heatsink
- solderable pin for PCB mounting
- specific versions upon customer's request

<table border="1"> <thead> <tr> <th>art. no.</th> <th>for transistor</th> <th>width [mm]</th> <th>R_{th} [K/W]</th> <th>spring force [N]</th> <th>version</th> </tr> </thead> <tbody> <tr> <td>SK 525 15</td> <td>TO 220</td> <td>15</td> <td>13.3</td> <td>54</td> <td>without solder pins</td> </tr> <tr> <td>SK 525 30</td> <td>TO 220</td> <td>30</td> <td>7.8</td> <td>100</td> <td>without solder pins</td> </tr> <tr> <td>SK 525 15 ST</td> <td>TO 220</td> <td>15</td> <td>13.3</td> <td>54</td> <td>with 1 solder pin</td> </tr> <tr> <td>SK 525 20 ST</td> <td>TO 220</td> <td>20</td> <td>10.7</td> <td>70</td> <td>with 1 solder pin</td> </tr> <tr> <td>SK 525 25 ST</td> <td>TO 220</td> <td>25</td> <td>9.0</td> <td>85</td> <td>with 2 solder pins</td> </tr> <tr> <td>SK 525 30 ST</td> <td>TO 220</td> <td>30</td> <td>7.8</td> <td>100</td> <td>with 2 solder pins</td> </tr> </tbody> </table>	art. no.	for transistor	width [mm]	R_{th} [K/W]	spring force [N]	version	SK 525 15	TO 220	15	13.3	54	without solder pins	SK 525 30	TO 220	30	7.8	100	without solder pins	SK 525 15 ST	TO 220	15	13.3	54	with 1 solder pin	SK 525 20 ST	TO 220	20	10.7	70	with 1 solder pin	SK 525 25 ST	TO 220	25	9.0	85	with 2 solder pins	SK 525 30 ST	TO 220	30	7.8	100	with 2 solder pins					
art. no.	for transistor	width [mm]	R_{th} [K/W]	spring force [N]	version																																										
SK 525 15	TO 220	15	13.3	54	without solder pins																																										
SK 525 30	TO 220	30	7.8	100	without solder pins																																										
SK 525 15 ST	TO 220	15	13.3	54	with 1 solder pin																																										
SK 525 20 ST	TO 220	20	10.7	70	with 1 solder pin																																										
SK 525 25 ST	TO 220	25	9.0	85	with 2 solder pins																																										
SK 525 30 ST	TO 220	30	7.8	100	with 2 solder pins																																										
<table border="1"> <thead> <tr> <th>art. no.</th> <th>for transistor</th> <th>width [mm]</th> <th>R_{th} [K/W]</th> <th>spring force [N]</th> <th>version</th> </tr> </thead> <tbody> <tr> <td>SK 526 30 ST</td> <td>TO 247</td> <td>30</td> <td>6.3</td> <td>100</td> <td>with 2 solder pins</td> </tr> </tbody> </table>	art. no.	for transistor	width [mm]	R_{th} [K/W]	spring force [N]	version	SK 526 30 ST	TO 247	30	6.3	100	with 2 solder pins																																			
art. no.	for transistor	width [mm]	R_{th} [K/W]	spring force [N]	version																																										
SK 526 30 ST	TO 247	30	6.3	100	with 2 solder pins																																										
surface:	black anodised																																														

Extruded heatsinks for PCB mounting

Extruded heatsinks for transistors

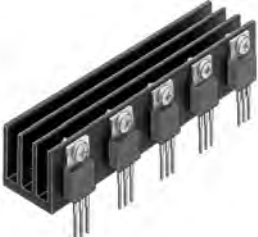
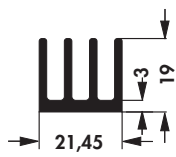
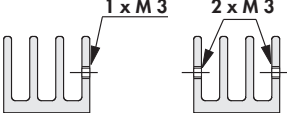
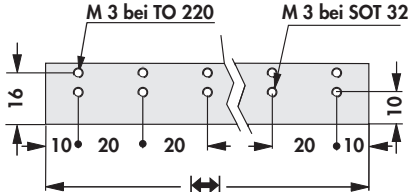
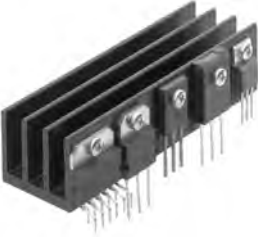
- compact PCB heatsink
- effective heat dissipation for single and double row transistor mounting
- profile **SK 454** → A 24
- profile **SK 452** → A 27
- specific versions upon customer's request

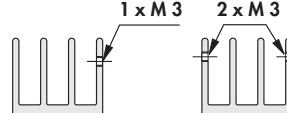
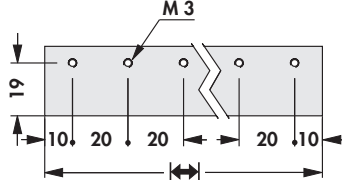
			
art. no.	↔ [mm]	R _{th} [K/W]	⊕
SK 454 20 1 x M3 ...	20	10.8	SOT 32/ TO 220
SK 454 60 3 x M3 ...	60	7.7	SOT 32/ TO 220
SK 454 20 2 x M3 ...	20	10.8	SOT 32/ TO 220
SK 454 40 4 x M3 ...	40	9.4	SOT 32/ TO 220
SK 454 60 6 x M3 ...	60	7.7	SOT 32/ TO 220
SK 454 40 2 x M3 TO 220	40	9.4	TO 220
SK 454 80 4 x M3 TO 220	80	6.5	TO 220
SK 454 100 5 x M3 TO 220	100	5.9	TO 220
SK 454 80 8 x M3 TO 220	80	6.5	TO 220
SK 454 100 10xM3 TO 220	100	5.9	TO 220
please indicate: ... ⊕			
SOT 32; TO 220			
			
art. no.	↔ [mm]	R _{th} [K/W]	⊕
SK 452 20 1 x M3	20	11.1	TO 218/ TO 220/ TO 247/ TO 248/ TO 3 P
SK 452 40 2 x M3	40	7.5	TO 218/ TO 220/ TO 247/ TO 248/ TO 3 P
SK 452 60 3 x M3	60	5.9	TO 218/ TO 220/ TO 247/ TO 248/ TO 3 P
SK 452 80 4 x M3	80	4.9	TO 218/ TO 220/ TO 247/ TO 248/ TO 3 P
SK 452 100 5 x M3	100	4.3	TO 218/ TO 220/ TO 247/ TO 248/ TO 3 P
SK 452 20 2 x M3	20	11.1	TO 218/ TO 220/ TO 247/ TO 248/ TO 3 P
SK 452 40 4 x M3	40	7.5	TO 218/ TO 220/ TO 247/ TO 248/ TO 3 P
SK 452 60 6 x M3	60	5.9	TO 218/ TO 220/ TO 247/ TO 248/ TO 3 P
SK 452 80 8 x M3	80	4.9	TO 218/ TO 220/ TO 247/ TO 248/ TO 3 P
SK 452 100 10 x M3	100	4.3	TO 218/ TO 220/ TO 247/ TO 248/ TO 3 P
surface:	black anodised		

Profiles for lock-in fixing spring
Assignment table
Thermal conductive material
Attachable heatsinks

→ A 84 - 88
→ A 18 - 20
→ E 2 - 5
→ C 10 - 16

Mica wafers
Kapton insulator washers
Thermal conductive paste
Technical introduction

→ E 19
→ E 16
→ E 21
→ A 2 - 8

Extruded heatsinks for PCB mounting

- for semiconductor clip-mounting
- special lengths and transistor drillings upon request
- **P** = raised retaining stud, **E** = mounting method

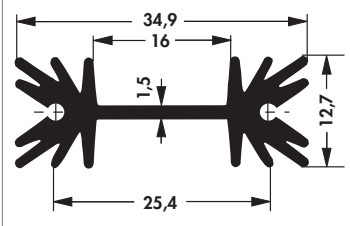
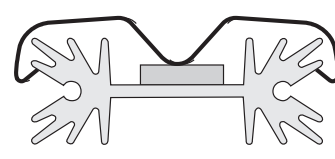
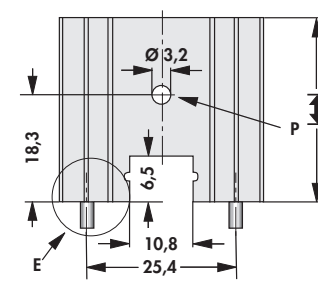
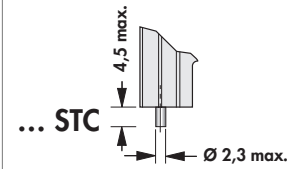
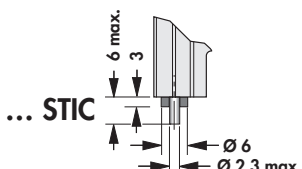
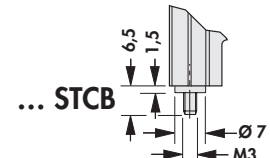
								
								
								
	art. no.	$\lvert \rvert$ [mm]	R_{th} [K/W]			\diamond		
	SK 104 25,4 ...	25.4	14			TO 220		
SK 104 38,1 ...	38.1	11	TO 220					
SK 104 50,8 ...	50.8	9	TO 220					
SK 104 63,5 ...	63.5	8	TO 220					
please indicate:	... mounting method							
	STC = with solder pin							
	STIC = with solder pin and insulating washer							
	STCB = with threaded bolt M 3, brass							
surface:	black anodised							

- for semiconductor screw-mounting
- special lengths and transistor drillings on request
- **E** = mounting method

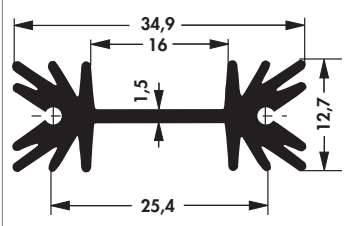
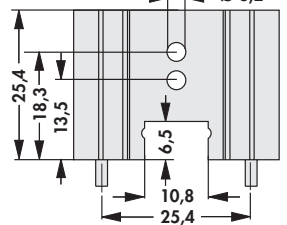
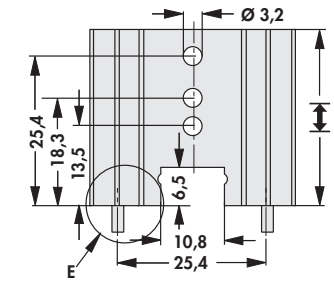
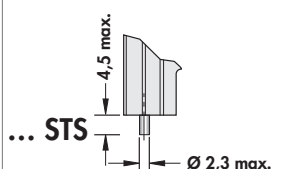
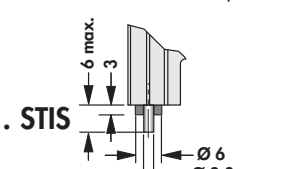
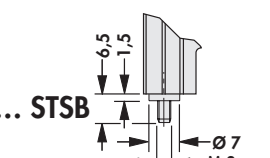
								
								
								
	art. no.	$\lvert \rvert$ [mm]	R_{th} [K/W]			\diamond		
	SK 104 25,4 ...	25.4	14			SOT 32/ TO 220/ TO 3 P		
SK 104 38,1 ...	38.1	11	SOT 32/ TO 220/ TO 3 P					
SK 104 50,8 ...	50.8	9	SOT 32/ TO 220/ TO 3 P					
SK 104 63,5 ...	63.5	8	SOT 32/ TO 220/ TO 3 P					
please indicate:	... mounting method							
	STS = with solder pin							
	STIS = with solder pins and insulating washer							
	STSB = with threaded bolt M 3, brass							
surface:	black anodised							

Extruded heatsinks for PCB mounting

- horizontal for semiconductor screw-mounting
- special lengths and transistor drillings on request

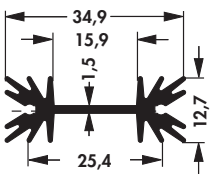
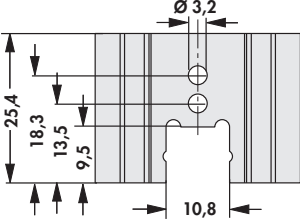
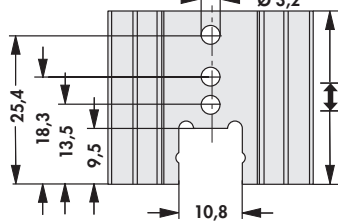
									
	art. no.	l [mm]	R _{th} [K/W]	⊗					
SK 104 25,4 LS	25.4	14	SOT 32/ TO 220/ TO 3 P						
SK 104 38,1 LS	38.1	11	SOT 32/ TO 220/ TO 3 P						
SK 104 50,8 LS	50.8	9	SOT 32/ TO 220/ TO 3 P						
surface:		black anodised							

Profiles for lock-in fixing spring
Assignment table
Thermal conductive material
Attachable heatsinks

→ A 84 - 88
→ A 18 - 20
→ E 2 - 5
→ C 10 - 16

Mica wafers
Kapton insulator washers
Thermal conductive paste
Technical introduction

→ E 19
→ E 16
→ E 21
→ A 2 - 8

Extruded heatsinks for PCB mounting

- for semiconductor clip-mounting
- special lengths and transistor drillings on request
- **P** = raised retaining stud, **E** = mounting method

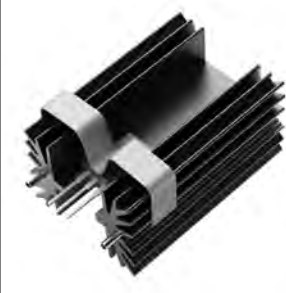
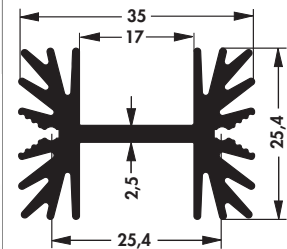
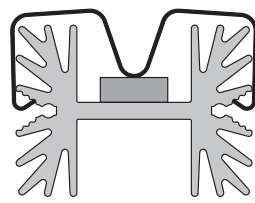
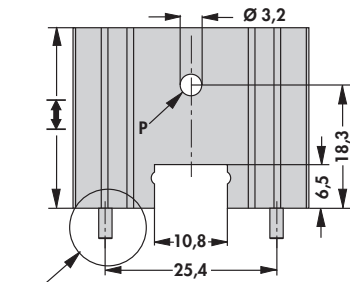
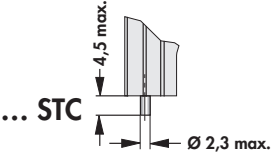
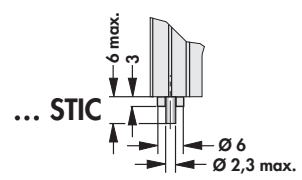
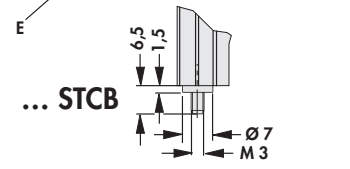
			
			
art. no.	\llbracket [mm]	R_{th} [K/W]	\diamond
SK 600 25,4 ...	25.4	11.0	TO 218/ TO 220/ TO 247/ TO 3 P
SK 600 38,1 ...	38.1	9.0	TO 218/ TO 220/ TO 247/ TO 3 P
SK 600 50,8 ...	50.8	7.3	TO 218/ TO 220/ TO 247/ TO 3 P
SK 600 63,5 ...	63.5	6.5	TO 218/ TO 220/ TO 247/ TO 3 P
please indicate:	... mounting method		
	STC = with solder pin		
	STIC = with solder pin and insulating washer		
	STCB = with threaded bolt M 3, brass		
surface:	black anodised		

- for semiconductor screw-mounting
- special lengths and transistor drillings on request
- **E** = mounting method

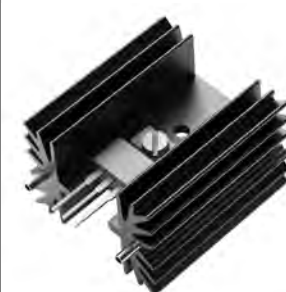
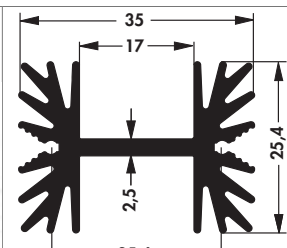
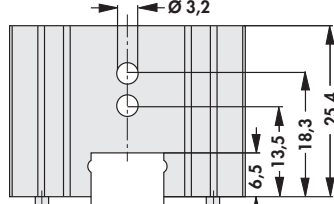
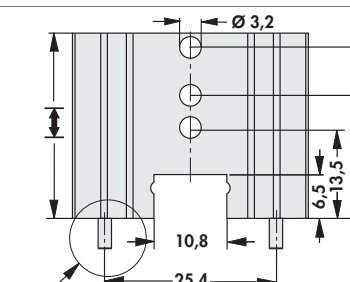
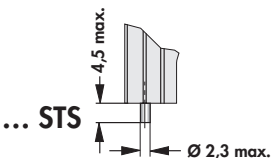
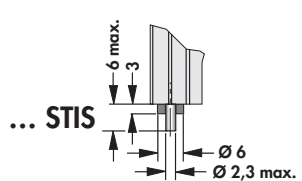
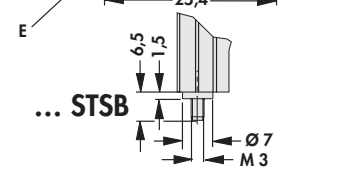
			
			
art. no.	\llbracket [mm]	R_{th} [K/W]	\diamond
SK 600 25,4 ...	25.4	11.0	TO 218/ TO 220/ TO 247/ TO 3 P
SK 600 38,1 ...	38.1	9.0	TO 218/ TO 220/ TO 247/ TO 3 P
SK 600 50,8 ...	50.8	7.3	TO 218/ TO 220/ TO 247/ TO 3 P
SK 600 63,5 ...	63.5	6.5	TO 218/ TO 220/ TO 247/ TO 3 P
please indicate:	... mounting method		
	STS = with solder pin		
	STIS = with solder pins and insulating washer		
	STSB = with threaded bolt M 3, brass		
surface:	black anodised		

Extruded heatsinks for PCB mounting

- for semiconductor clip-mounting
- special lengths and transistor drillings on request
- **P** = raised retaining stud, **E** = mounting method

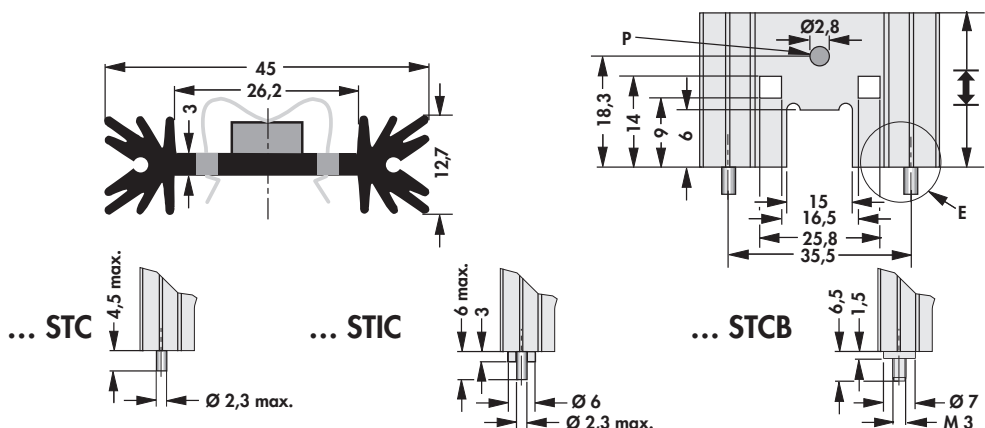



art. no.	l [mm]	R _{th} [K/W]	⌀
SK 409 25,4 ...	25.4	8.2	TO 220/ TO 3 P
SK 409 38,1 ...	38.1	7.0	TO 220/ TO 3 P
SK 409 50,8 ...	50.8	6.2	TO 220/ TO 3 P
SK 409 63,5 ...	63.5	5.6	TO 220/ TO 3 P

please indicate: ... mounting method
STC = with solder pin
STIC = with solder pin and insulating washer
STCB = with threaded bolt M 3, brass

surface: black anodised

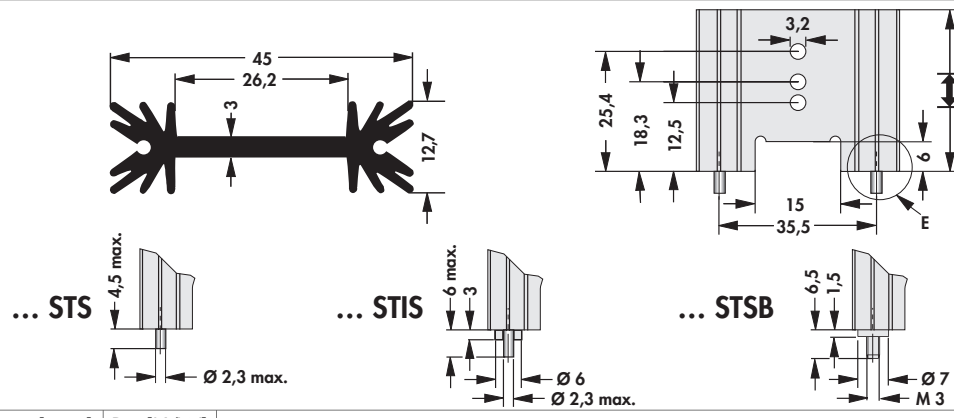
- for semiconductor screw-mounting
- special lengths and transistor drillings on request
- **E** = mounting method

art. no.	l [mm]	R _{th} [K/W]	⌀
SK 409 25,4 ...	25.4	8.2	TO 220/ TO 3 P
SK 409 38,1 ...	38.1	7.0	TO 220/ TO 3 P
SK 409 50,8 ...	50.8	6.2	TO 220/ TO 3 P
SK 409 63,5 ...	63.5	5.6	TO 220/ TO 3 P

please indicate: ... mounting method
STS = with solder pin
STIS = with solder pins and insulating washer
STSB = with threaded bolt M 3, brass

surface: black anodised

Profiles for lock-in fixing spring
 Assignment table
 Thermal conductive material
 Attachable heatsinks

→ A 84 - 88
 → A 18 - 20
 → E 2 - 5
 → C 10 - 16

Mica wafers
 Kapton insulator washers
 Thermal conductive paste
 Technical introduction

→ E 19
 → E 16
 → E 21
 → A 2 - 8

Extruded heatsinks for PCB mounting

- for semiconductor clip-mounting
- special lengths and transistor drillings on request
- **E** = mounting method

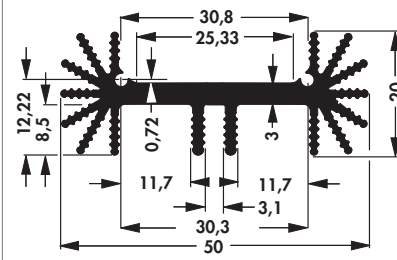
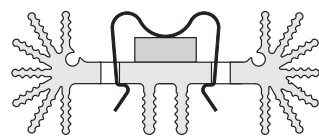
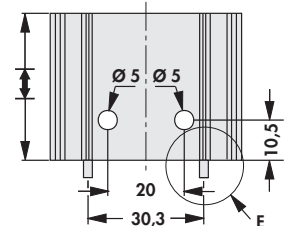
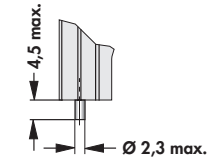
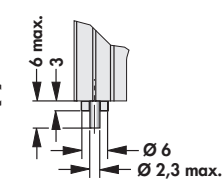
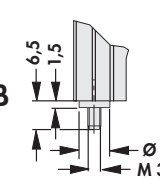
				
	 <p>... STC</p>	 <p>... STIC</p>	 <p>... STCB</p>	
art. no.	l [mm]	R _{th} [K/W]	⊕	
SK 459 25 ...	25.0	7.9	TO 218/ TO 220/ TO 247/ TO 248	
SK 459 37,5 ...	37.5	6.3	TO 218/ TO 220/ TO 247/ TO 248	
SK 459 50 ...	50.0	5.6	TO 218/ TO 220/ TO 247/ TO 248	
please indicate:	... mounting method			
	STC = with solder pin			
	STIC = with solder pin and insulating washer			
	STCB = with threaded bolt M 3, brass			
surface:	black anodised			

- for semiconductor screw-mounting
- special lengths and transistor drillings on request
- **E** = mounting method

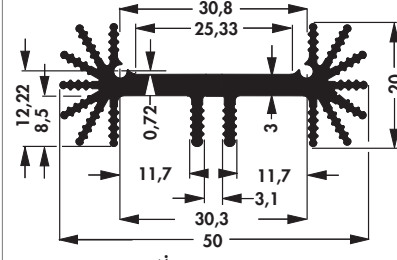
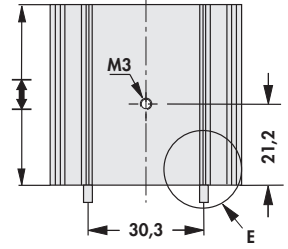
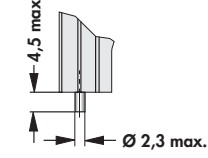
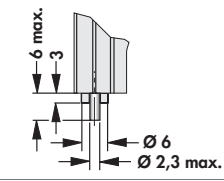
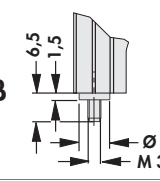
			
	 <p>... STS</p>	 <p>... STIS</p>	 <p>... STSB</p>
art. no.	l [mm]	R _{th} [K/W]	⊕
SK 459 25 ...	25.0	7.9	TO 218/ TO 220/ TO 247/ TO 248
SK 459 37,5 ...	37.5	6.3	TO 218/ TO 220/ TO 247/ TO 248
SK 459 50 ...	50.0	5.6	TO 218/ TO 220/ TO 247/ TO 248
please indicate:	... mounting method		
	STS = with solder pin		
	STIS = with solder pins and insulating washer		
	STSB = with threaded bolt M 3, brass		
surface:	black anodised		

Extruded heatsinks for PCB mounting

- for semiconductor screw-mounting
- special lengths and transistor drillings on request
- **E** = mounting method

	<p>... STS</p>	<p>... STIS</p>	<p>... STSB</p>		
				$\varnothing 2,3 \text{ max.}$	$\varnothing 6$ $\varnothing 2,3 \text{ max.}$
				$\varnothing 7$ M 3	
art. no.	l [mm]	R_{th} [K/W]	⚙		
SK 459 25 M ...	25.0	7.9	SIP-Multiwatt		
SK 459 37,5 M ...	37.5	6.3	SIP-Multiwatt		
SK 459 50 M ...	50.0	5.6	SIP-Multiwatt		
please indicate:	... mounting method STS = with solder pin STIS = with solder pins and insulating washer STSB = with threaded bolt M 3, brass				
surface:	black anodised				

- for semiconductor screw-mounting
- with **combination-hole pattern** for mounting of 2 x TO 220 or 2 x SOT 32
- special lengths and transistor drillings on request
- **E** = mounting method

	<p>... STS</p>	<p>... STIS</p>	<p>... STSB</p>		
				$\varnothing 2,3 \text{ max.}$	$\varnothing 6$ $\varnothing 2,3 \text{ max.}$
				$\varnothing 7$ M 3	
art. no.	l [mm]	R_{th} [K/W]	⚙		
SK 459 25 2 x TO 220 ...	25.0	7.9	2xSOT 32/ 2xTO 220		
SK 459 37,5 2 x TO 220...	37.5	6.3	2xSOT 32/ 2xTO 220		
SK 459 50 2 x TO 220 ...	50.0	5.6	2xSOT 32/ 2xTO 220		
please indicate:	... mounting method STS = with solder pin STIS = with solder pins and insulating washer STSB = with threaded bolt M 3, brass				
surface:	black anodised				

Profiles for lock-in fixing spring
 Assignment table
 Thermal conductive material
 Attachable heatsinks

→ A 84 - 88
 → A 18 - 20
 → E 2 - 5
 → C 10 - 16

Mica wafers
 Kapton insulator washers
 Thermal conductive paste
 Technical introduction

→ E 19
 → E 16
 → E 21
 → A 2 - 8

Extruded heatsinks for PCB mounting

- for semiconductor clip-mounting
- special lengths and transistor drillings on request
- **P** = raised retaining stud, **E** = mounting method

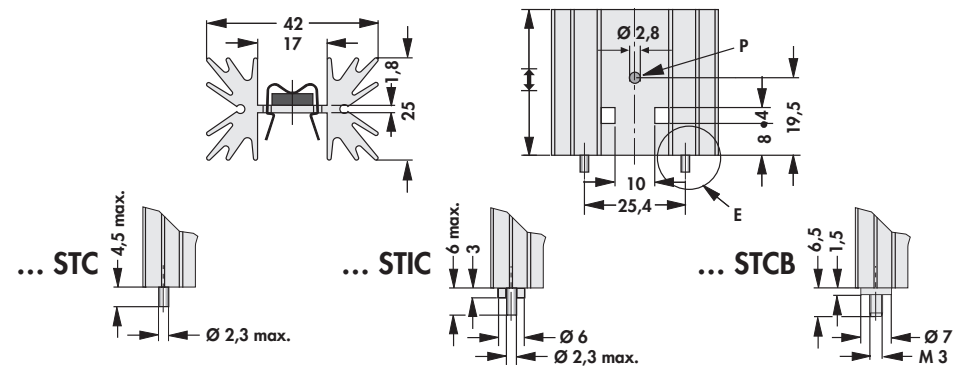
			
	art. no.	$\lvert \rvert$ [mm]	R_{th} [K/W]
SK 129 25,4 ...	25.4	7.8	TO 220
SK 129 38,1 ...	38.1	6.5	TO 220
SK 129 50,8 ...	50.8	5.3	TO 220
SK 129 63,5 ...	63.5	4.5	TO 220
please indicate:	... mounting method		
	STC = with solder pin		
	STIC = with solder pin and insulating washer		
	STCB = with threaded bolt M 3, brass		
surface:	black anodised		

- for semiconductor screw-mounting
- special lengths and transistor drillings on request
- **E** = mounting method

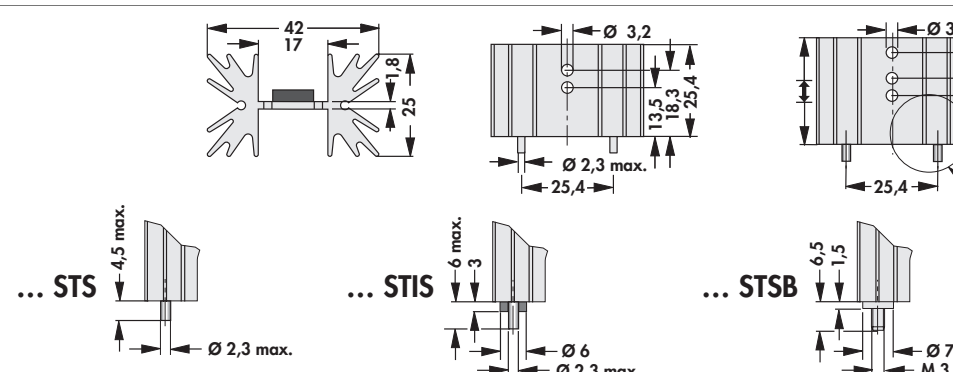
			
	art. no.	$\lvert \rvert$ [mm]	R_{th} [K/W]
SK 129 25,4 ...	25.4	7.8	SOT 32/ TO 220/ TO 3 P
SK 129 38,1 ...	38.1	6.5	SOT 32/ TO 220/ TO 3 P
SK 129 50,8 ...	50.8	5.3	SOT 32/ TO 220/ TO 3 P
SK 129 63,5 ...	63.5	4.5	SOT 32/ TO 220/ TO 3 P
please indicate:	... mounting method		
	STS = with solder pin		
	STIS = with solder pins and insulating washer		
	STSB = with threaded bolt M 3, brass		
surface:	black anodised		

Extruded heatsinks for PCB mounting

- for semiconductor clip-mounting
- profile **SK 185** → A 73
- special lengths and drillings on request
- **L** = solderable pins

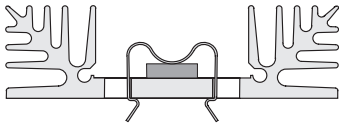
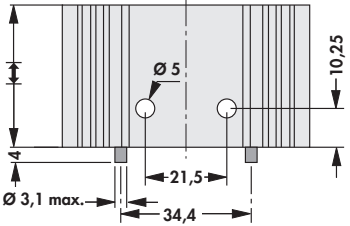

				
art. no.	↔ [mm]	R _{th} [K/W]	⊗	version
SK 185 25 STC TO 220	25.0	7.9	TO 220	with solder pins
SK 185 37,5 STC TO 220	37.5	6.4	TO 220	with solder pins
SK 185 50 STC TO 220	50.0	4.9	TO 220	with solder pins
SK 185 50 C TO 220	50.0	4.9	TO 220	without solder pins
surface:		black anodised		

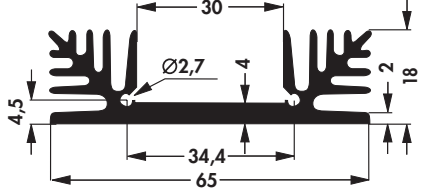
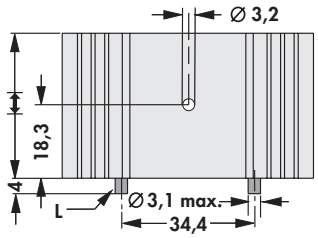
- for semiconductor screw-mounting
- profile **SK 185** → A 73
- special lengths and drillings on request
- **L** = solderable pins

				
art. no.	↔ [mm]	R _{th} [K/W]	⊗	version
SK 185 25 STS TO 220	25.0	7.9	TO 220	with solder pins
SK 185 37,5 STS TO 220	37.5	6.4	TO 220	with solder pins
SK 185 50 STS TO 220	50.0	4.9	TO 220	with solder pins
SK 185 25 TO 220	25.0	7.9	TO 220	without solder pins
SK 185 37,5 TO 220	37.5	6.4	TO 220	without solder pins
SK 185 50 TO 220	50.0	4.9	TO 220	without solder pins
surface:		black anodised		

Extruded heatsinks for PCB mounting

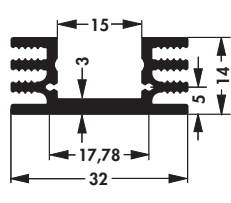
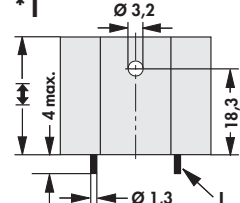
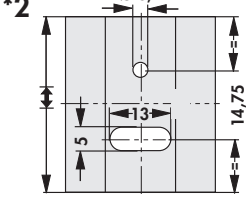
- for semiconductor screw-mounting
- hole pattern is centered to the total length of the heatsink
- special lengths and drillings on request
- *1 = versions with solder pins; *2 = versions without solder pins
- L = solderable pins

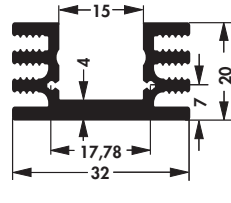
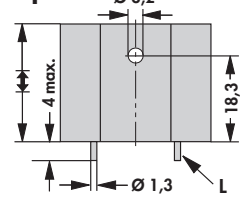
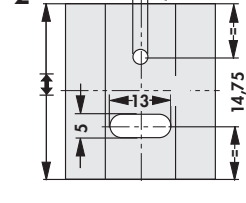
				
art. no.	↔ [mm]	R _{th} [K/W]	⌀	version
SK 75 25 STS TO 220	25.0	12.5	TO 220/*1	with solder pins
SK 75 37,5 STS TO 220	37.5	10.0	TO 220/*1	with solder pins
SK 75 50 STS TO 220	50.0	8.5	TO 220/*1	with solder pins
SK 75 25	25.0	12.5	—	without solder pins
SK 75 25 TO 220	25.0	12.5	TO 220/*2	without solder pins
SK 75 37,5	37.5	10.0	—	without solder pins
SK 75 37,5 TO 220	37.5	10.0	TO 220/*2	without solder pins
SK 75 50	50.0	8.5	—	without solder pins
SK 75 50 TO 220	50.0	8.5	TO 220/*2	without solder pins
SK 75 75	75.0	7.0	—	without solder pins
SK 75 1000	1000.0	—	—	without solder pins
				
art. no.	↔ [mm]	R _{th} [K/W]	⌀	version
SK 76 25 STS TO 220	25.0	10.0	TO 220/*1	with solder pins
SK 76 37,5 STS TO 220	37.5	8.0	TO 220/*1	with solder pins
SK 76 50 STS TO 220	50.0	7.0	TO 220/*1	with solder pins
SK 76 25	25.0	10.0	—	without solder pins
SK 76 25 TO 220	25.0	10.0	TO 220/*2	without solder pins
SK 76 37,5	37.5	8.0	—	without solder pins
SK 76 37,5 TO 220	37.5	8.0	TO 220/*2	without solder pins
SK 76 50	50.0	7.0	—	without solder pins
SK 76 50 TO 220	50.0	7.0	TO 220/*2	without solder pins
SK 76 75	75.0	5.9	—	without solder pins
SK 76 1000	1000.0	—	—	without solder pins
surface:	black anodised			

Extruded heatsinks for PCB mounting

- for semiconductor clip-mounting
- profile **SK 145** → A 73
- special lengths and drillings on request
- **L** = solderable pins

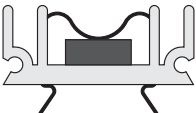
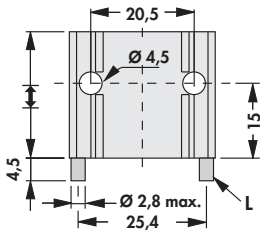
				
art. no.	l [mm]	R _{th} [K/W]	⌀	version
SK 145 25 STC	25	13.5	TO 218/ TO 220/ TO 247/ TO 248	with solder pins
SK 145 30 STC	30	12.4	TO 218/ TO 220/ TO 247/ TO 248	with solder pins
SK 145 50 STC	50	10.0	TO 218/ TO 220/ TO 247/ TO 248	with solder pins
surface:	black anodised			

- for semiconductor screw-mounting
- profile **SK 145** → A 73
- special lengths and drillings on request
- **L** = solderable pins

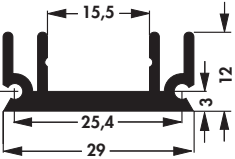
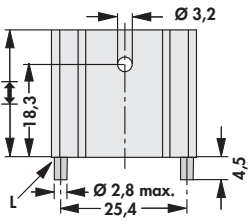
				
art. no.	l [mm]	R _{th} [K/W]	⌀	version
SK 145 25 STS TO 220	25.0	13.5	TO 218/ TO 220/ TO 247/ TO 248	with solder pins
SK 145 37,5 STS TO 220	37.5	12.0	TO 218/ TO 220/ TO 247/ TO 248	with solder pins
SK 145 50 STS TO 220	50.0	10.0	TO 218/ TO 220/ TO 247/ TO 248	with solder pins
surface:	black anodised			

Extruded heatsinks for PCB mounting

- special lengths and drillings on request
- L = solderable pins

art. no.	↔ [mm]	R _{th} [K/W]	⌀	version
SK 126 25 STS TO 220	25.0	8.0	TO 218/ TO 220/ TO 247/ TO 248	with solder pin and thread M3
SK 126 37,5 STS TO 220	37.5	6.5	TO 218/ TO 220/ TO 247/ TO 248	with solder pin and thread M3
SK 126 25 TO 220	25.0	8.0	TO 218/ TO 220/ TO 247/ TO 248	ohne Lötstift, mit M3-Gewinde
SK 126 25 2 x M3	25.0	8.0	TO 218/ TO 220/ TO 247/ TO 248	ohne Lötstift, mit M3-Gewinde
SK 126 37,5 TO 220	37.5	6.5	TO 218/ TO 220/ TO 247/ TO 248	ohne Lötstift, mit M3-Gewinde
SK 126 37,5 2 x M3	37.5	6.5	TO 218/ TO 220/ TO 247/ TO 248	ohne Lötstift, mit M3-Gewinde
SK 126 25	25.0	8.0	—	—
SK 126 37,5	37.5	6.5	—	—
SK 126 1000	1000.0	—	—	—
surface:		black anodised		



SK 126 25 TO 220
SK 126 37,5 TO 220

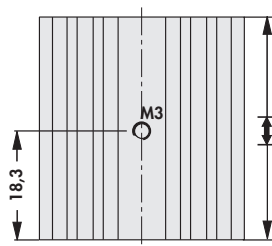
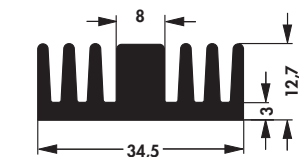

SK 126 25 STS TO 220
SK 126 37,5 STS TO 220

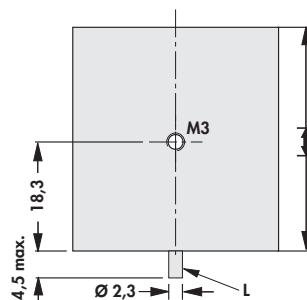
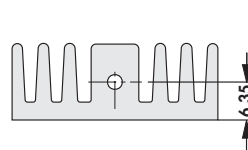

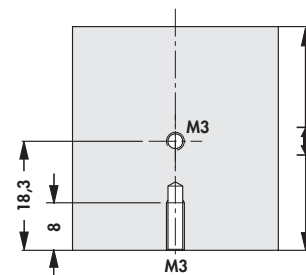
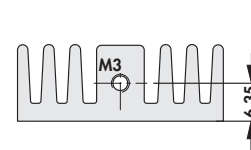

SK 126 25 2 x M 3
SK 126 37,5 2 x M 3

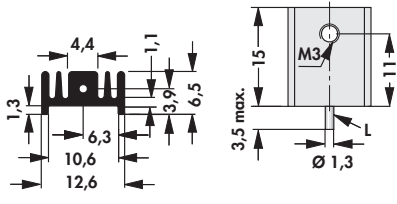
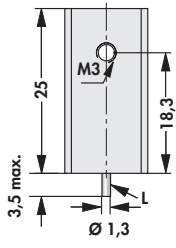
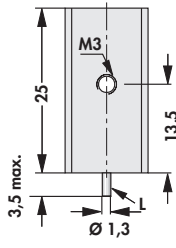

Extruded heatsinks for PCB mounting

- special lengths and drillings on request
- **L** = solderable pins

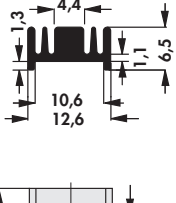
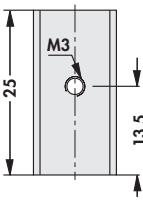
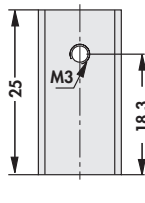
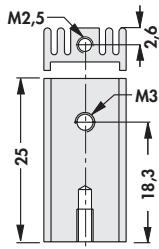
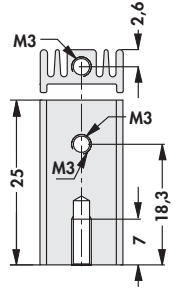
						
	SK 95 15 STS SOT 32 S		SK 95 25 STS TO 220		SK 95 25 STS SOT 32	
	art. no.	[mm]	R_{th} [K/W]	⌀		
	SK 95 15 STS SOT 32 S	15	38.5	SOT 32		
SK 95 25 STS SOT 32	25	36.0	SOT 32			
SK 95 25 STS TO 220	25	36.0	TO 220			
			SK 95 25 1 x M2,5 1 x M3			
						
			SK 95 25 2 x M3			
	art. no.	[mm]	R_{th} [K/W]	⌀		
	SK 95 15 SOT 32 S	15	38.5	SOT 32		
	SK 95 25 SOT 32	25	36.0	SOT 32		
	SK 95 25 TO 220	25	36.0	TO 220		
SK 95 25 1 x M2,5 1 x M3	25	36.0	1xM2.5/ 1xM3 (TO 220)			
SK 95 25 2 x M3	25	36.0	2xM3 (TO 220)			
SK 95 15	15	38.5	—			
SK 95 25	25	36.0	—			
SK 95 1000	1000	—	—			
surface:		black anodised				
type of thread:		not anodised				

Profiles for lock-in fixing spring
Assignment table
Thermal conductive material
Attachable heatsinks

→ A 84 – 88
→ A 18 – 20
→ E 2 – 5
→ C 10 – 16



Mica wafers
Kapton insulator washers
Thermal conductive paste
Technical introduction

→ E 19
→ E 16
→ E 21
→ A 2 – 8

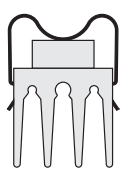
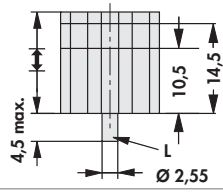

A 108

Extruded heatsinks for PCB mounting

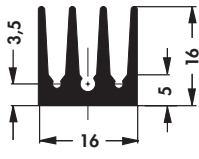
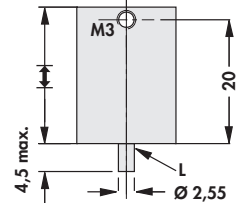
- single solder pin
- profile **SK 437** → A 24
- special lengths and drillings on request
- **L** = solderable pin

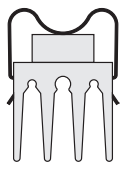
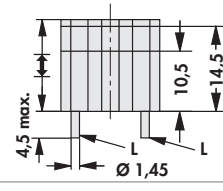

			
art. no.	↔ [mm]	R _{th} [K/W]	⊕
SK 437 25 STC	25	24	TO 218/ TO 220/ TO 247/ TO 248
SK 437 30 STC	30	22	TO 218/ TO 220/ TO 247/ TO 248
SK 437 35 STC	35	18	TO 218/ TO 220/ TO 247/ TO 248
SK 437 50 STC	50	14	TO 218/ TO 220/ TO 247/ TO 248
			
art. no.	↔ [mm]	R _{th} [K/W]	⊕
SK 437 25 STS	25	24	TO 218/ TO 220/ TO 247/ TO 248
SK 437 30 STS	30	22	TO 218/ TO 220/ TO 247/ TO 248
SK 437 35 STS	35	18	TO 218/ TO 220/ TO 247/ TO 248
SK 437 50 STS	50	14	TO 218/ TO 220/ TO 247/ TO 248
surface:	black anodised		

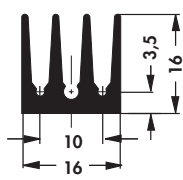
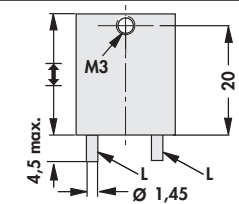
- double solder pin
- profile **SK 437** → A 24
- special lengths and drillings on request
- **L** = solderable pin

			
art. no.	↔ [mm]	R _{th} [K/W]	⊕
SK 437 25 STC 2	25	24	TO 218/ TO 220/ TO 247/ TO 248
SK 437 30 STC 2	30	22	TO 218/ TO 220/ TO 247/ TO 248
SK 437 35 STC 2	35	18	TO 218/ TO 220/ TO 247/ TO 248
			
art. no.	↔ [mm]	R _{th} [K/W]	⊕
SK 437 25 STS 2	25	24	TO 218/ TO 220/ TO 247/ TO 248
SK 437 30 STS 2	30	22	TO 218/ TO 220/ TO 247/ TO 248
SK 437 35 STS 2	35	18	TO 218/ TO 220/ TO 247/ TO 248
surface:	black anodised		

Extruded heatsinks for PCB mounting

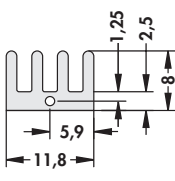
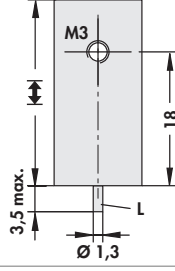
- special versions on customer's request
- L = solderable pin

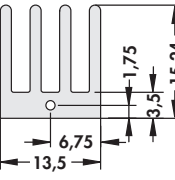
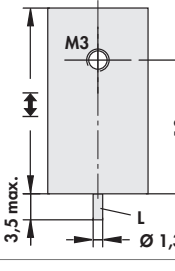
			
art. no.	↔ [mm]	R _{th} [K/W]	⊕
SK 470 25 STS	25	29.0	SOT 32/ TO 220
SK 470 30 STS	30	27.2	SOT 32/ TO 220
SK 470 35 STS	35	25.6	SOT 32/ TO 220
SK 470 50 STS	50	23.2	SOT 32/ TO 220
			
art. no.	↔ [mm]	R _{th} [K/W]	⊕
SK 469 25 STS	25	15.3	SOT 32/ TO 220
SK 469 30 STS	30	14.3	SOT 32/ TO 220
SK 469 35 STS	35	13.0	SOT 32/ TO 220
SK 469 50 STS	50	10.6	SOT 32/ TO 220
surface:	black anodised		

- as mounting- and connecting piece
- for clamp mounting of the transistors
- triple unit can be separated
- solder pin mounting possible
- special versions on customer's request

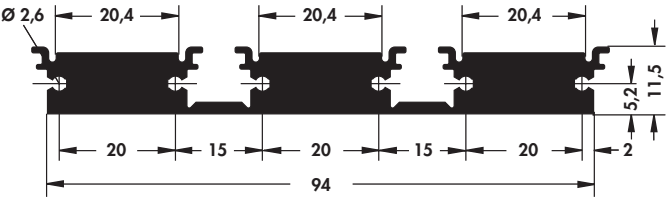
			
art. no.	↔ [mm]	R _{th} [K/W]	⊕
SK 484 25	25.0	6.0	TO 218/ TO 220/ TO 247/ TO 264/ TO 3 P
SK 484 37,5	37.5	4.5	TO 218/ TO 220/ TO 247/ TO 264/ TO 3 P
SK 484 50	50.0	3.7	TO 218/ TO 220/ TO 247/ TO 264/ TO 3 P
SK 484 75	75.0	2.8	TO 218/ TO 220/ TO 247/ TO 264/ TO 3 P

Profiles for lock-in fixing spring
Assignment table
Thermal conductive material
Attachable heatsinks







→ A 84 - 88
→ A 18 - 20
→ E 2 - 5
→ C 10 - 16

Mica wafers
Kapton insulator washers
Thermal conductive paste
Technical introduction

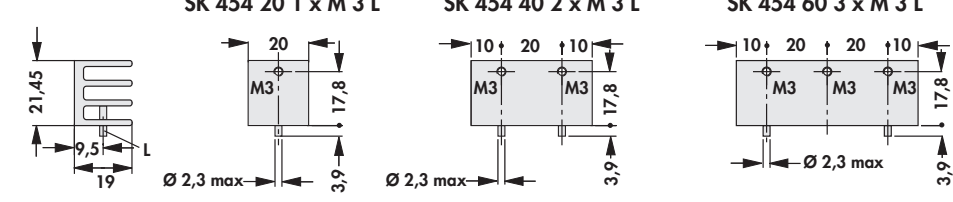
→ E 19
→ E 16
→ E 21
→ A 2 - 8

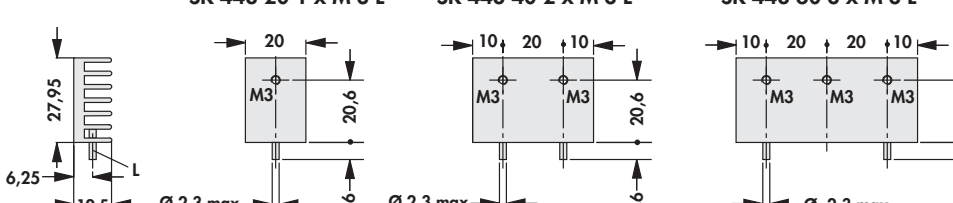
Extruded heatsinks for PCB mounting

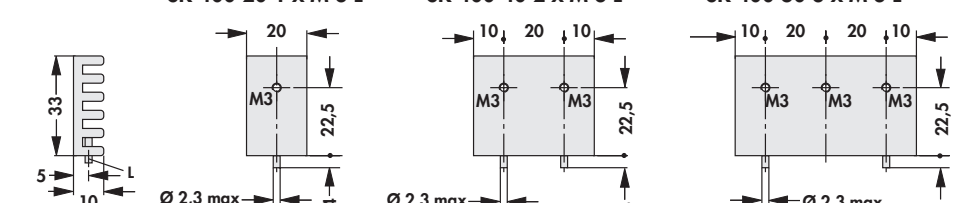
- compact PCB heatsinks
- especially suitable for vertical PCB mounting in housings, racks etc.
- easy solder fixing
- special versions on customer's request
- **L** = solderable pin

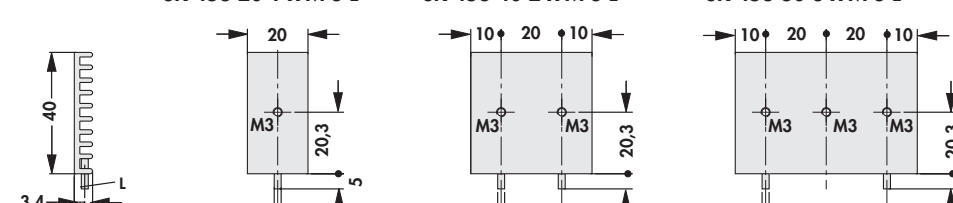
	SK 454 20 1 x M3 L	SK 454 40 2 x M3 L	SK 454 60 3 x M3 L
			
art. no.	↔ [mm]	R_{th} [K/W]	⚡
SK 454 20 1 x M3 L	20	10.1	SOT 32/ TO 220
SK 454 40 2 x M3 L	40	8.8	SOT 32/ TO 220
SK 454 60 3 x M3 L	60	7.5	SOT 32/ TO 220
	SK 448 20 1 x M3 L	SK 448 40 2 x M3 L	SK 448 60 3 x M3 L
			
art. no.	↔ [mm]	R_{th} [K/W]	⚡
SK 448 20 1 x M3 L	20	11.8	TO 218/ TO 220/ TO 247/ TO 248/ TO 3 P
SK 448 40 2 x M3 L	40	9.8	TO 218/ TO 220/ TO 247/ TO 248/ TO 3 P
SK 448 60 3 x M3 L	60	7.1	TO 218/ TO 220/ TO 247/ TO 248/ TO 3 P
	SK 400 20 1 x M3 L	SK 400 40 2 x M3 L	SK 400 60 3 x M3 L
			
art. no.	↔ [mm]	R_{th} [K/W]	⚡
SK 400 20 1 x M3 L	20	11.6	TO 218/ TO 220/ TO 247/ TO 248/ TO 3 P
SK 400 40 2 x M3 L	40	8.2	TO 218/ TO 220/ TO 247/ TO 248/ TO 3 P
SK 400 60 3 x M3 L	60	7.2	TO 218/ TO 220/ TO 247/ TO 248/ TO 3 P
	SK 456 20 1 x M3 L	SK 456 40 2 x M3 L	SK 456 60 3 x M3 L
			
art. no.	↔ [mm]	R_{th} [K/W]	⚡
SK 456 20 1 x M3 L	20	13.0	TO 218/ TO 220/ TO 247/ TO 248/ TO 3 P
SK 456 40 2 x M3 L	40	10.5	TO 218/ TO 220/ TO 247/ TO 248/ TO 3 P
SK 456 60 3 x M3 L	60	8.5	TO 218/ TO 220/ TO 247/ TO 248/ TO 3 P

Extruded heatsinks for PCB mounting

- for semiconductor clip-mounting
- special lengths and transistor drillings on request
- **E** = mounting method

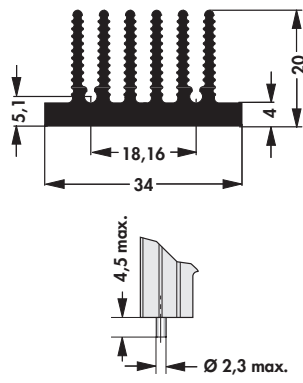
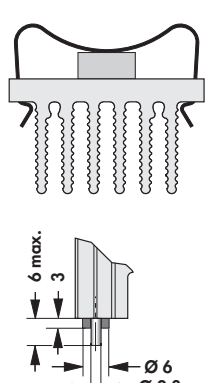
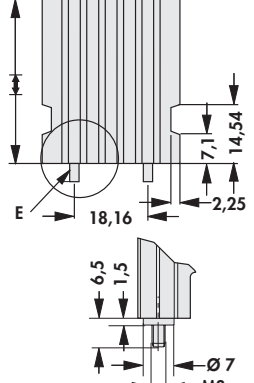
	 <p>... STC</p>		 <p>... STIC</p>	 <p>... STCB</p>
	art. no.	↔ [mm]	R_{th} [K/W]	⊕
SK 460 25 ...	25.0	9.0	SIP-Multiwatt/ TO 218/ TO 220/ TO 247/ TO 248	
SK 460 37,5 ...	37.5	7.9	SIP-Multiwatt/ TO 218/ TO 220/ TO 247/ TO 248	
SK 460 50 ...	50.0	7.0	SIP-Multiwatt/ TO 218/ TO 220/ TO 247/ TO 248	
please indicate:				
	... mounting method			
	STC = with solder pin			
	STIC = with solder pin and insulating washer			
	STCB = with threaded bolt M 3, brass			
surface:	black anodised			

- for semiconductor screw-mounting
- special lengths and transistor drillings on request
- **E** = mounting method

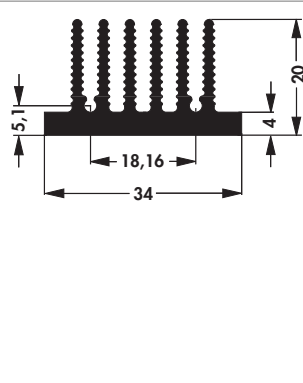
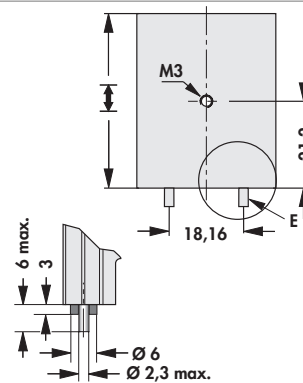
	 <p>STS</p>		 <p>STIS</p>
	art. no.	↔ [mm]	R_{th} [K/W]
SK 460 25 STS	25.0	9.0	SIP-Multiwatt/ TO 218/ TO 220/ TO 247/ TO 248
SK 460 37,5 STS	37.5	7.9	SIP-Multiwatt/ TO 218/ TO 220/ TO 247/ TO 248
SK 460 50 STIS	50.0	7.0	SIP-Multiwatt/ TO 218/ TO 220/ TO 247/ TO 248
surface:	black anodised		

Profiles for lock-in fixing spring
 Assignment table
 Thermal conductive material
 Attachable heatsinks

→ A 84 - 88
 → A 18 - 20
 → E 2 - 5
 → C 10 - 16

Mica wafers
 Kapton insulator washers
 Thermal conductive paste
 Technical introduction

→ E 19
 → E 16
 → E 21
 → A 2 - 8

Extruded heatsinks for DC/DC converter

– special versions on customer's request

art. no. SK DC 10 60 SA		
art. no. SK DC 8 60 SA		
art. no. SK DC 8 1 60 SA		
art. no. SK DC 4 1 117 SA		
art. no. SK DC 6 1 60 SA		
surface:		black anodised

A 113

Heatsink profile-overview

Drilling pattern for Solid State Relais

Heatsinks for Solid State Relais

Special profiles

→ A 13 – 17

→ A 12

→ A 11 – 12

→ A 140

Standard aluminium profiles

Extruded heatsinks

Profiles for PCB mounting

Technical introduction

→ A 135 – 136

→ A 22 – 83

→ A 89 – 112

→ A 2 – 8

Extruded heatsinks for DC/DC converter

– special versions on customer's request



<p>art. no.</p> <p>SK DC 7 117 SA</p>		
<p>art. no.</p> <p>SK DC 7 1 117 SA</p>		
<p>art. no.</p> <p>SK DC 2 1 76 SA</p>		
<p>art. no.</p> <p>SK DC 5 59 SA</p>		
<p>art. no.</p> <p>SK DC 5 1 59 SA</p>		
<p>surface:</p>		<p>black anodised</p>

Heatsink profile-overview → A 13 - 17
 Drilling pattern for Solid State Relais → A 12
 Heatsinks for Solid State Relais → A 11 - 12
 Special profiles → A 140

Standard aluminium profiles → A 135 - 136
 Extruded heatsinks → A 22 - 83
 Profiles for PCB mounting → A 89 - 112
 Technical introduction → A 2 - 8

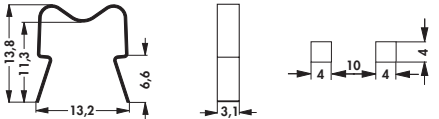
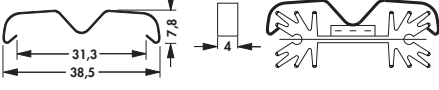
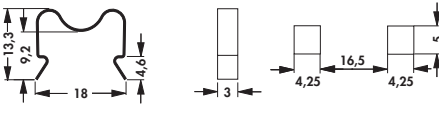
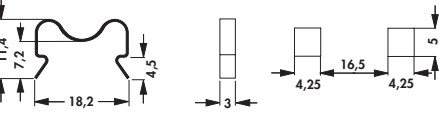
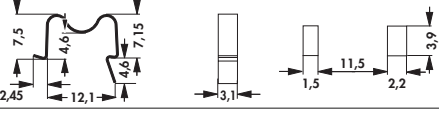

A 114

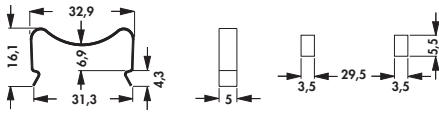
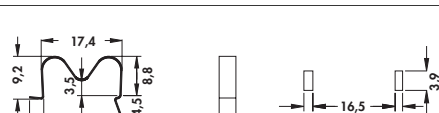
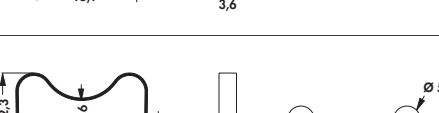
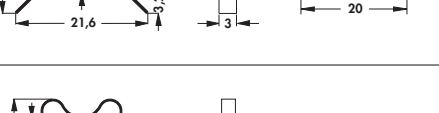
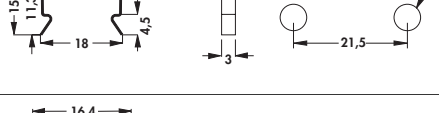
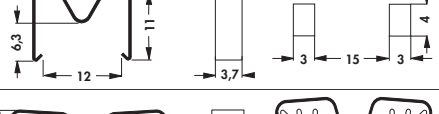

Retaining springs for transistors

art. no.	for transistor-housing	suitable for heatsinks	plate thickness [mm]	material	
THF 129 TO 220	TO 220	FK 219/ FK 222/ SK 129	1-2	spring steel, corrosion protected	
THF 104	TO 220/ TO 247/ TO 248/ TO 3 P	SK 104	1-2	stainless steel	
THF 409 TO 220	TO 220/ TO 247/ TO 248/ TO 3 P	SK 409	1.5-3.0	stainless steel	
THF 409 SOT 32	TO 126/ SOT 32/ SOT 82	SK 409	2-3	stainless steel	
THF 220	TO 220	FK 219/ FK 222	1-2	spring steel, corrosion protected	
THF 247	TO 220/ TO 247/ TO 248/ TO 3 P	SK 484	2	stainless steel	
THF 247 4	TO 218/ TO 220/ TO 247/ TO 248/ TO 3 P	SK 460	4	stainless steel	
THF 220 17	TO 218/ TO 220/ TO 247/ TO 248/ TO 3 P	UK 35	1.0-1.5	stainless steel	
THF 409 220 1	TO 218/ TO 220/ TO 247/ TO 248/ TO 3 P	SK 409/ SK 459	2-3	stainless steel	
THF 409 220 2	TO 218/ TO 220/ TO 247/ TO 248/ TO 3 P	SK 145/ SK 185/ SK 437	4	stainless steel	
THF 249	TO 220	FK 249	1.0-1.5	spring steel, corrosion protected	
THF 600	TO 218/ TO 220/ TO 247/ TO 3 P	SK 600	2.5	spring steel, corrosion protected	

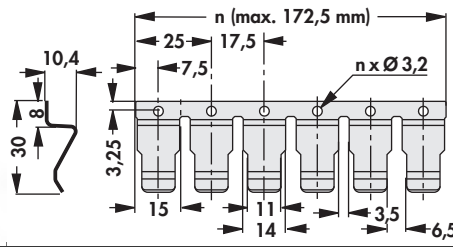
Retaining springs for transistors

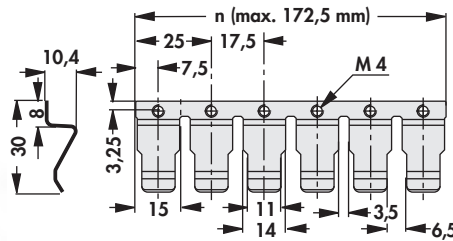

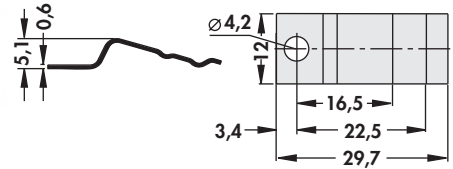

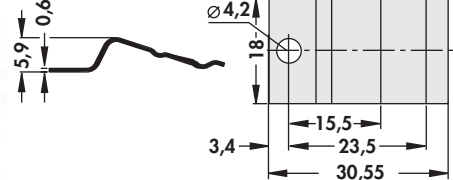

- universal **retaining spring** for transistor housings types TO 218, TO 220, TO 247, TO 264, SOT 32 and various SIP Multiwatt etc.
- utility patent 200 14 739.0
- fast and easy mounting of the transistors
- number of retaining spring elements can be chosen (**n = max. 10**)
- **THFMG** with thread M 4
- specific versions and modifications on customer's request

art. no.	for transistor-housing	spring force [N]	material	
THFM ...	TO 218/ TO 220/ TO 247/ TO 264/ SOT 32/ SIP Multiwatt	60 ±5	stainless steel	 
THFMG ...	TO 218/ TO 220/ TO 247/ TO 264/ SOT 32/ SIP Multiwatt	60 ±5	stainless steel	 
please indicate: ... number of retaining-spring elements 1 - 10				

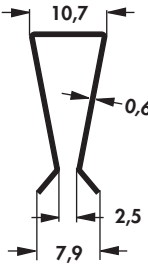
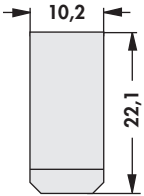
art. no.	for transistor-housing	spring force [N]	material	
THFK 220	TO 220	79	stainless steel	 
THFK 247	TO 218/ TO 247	119	stainless steel	 

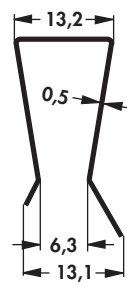
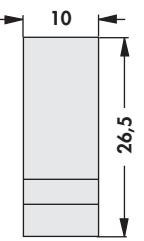
Retaining springs for transistors

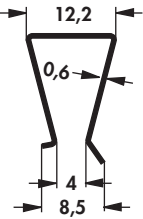
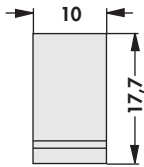
- able to slide on the transistor and mounting plate
- easy mounting
- high pressure force and firm grip
- specific versions upon customer's request

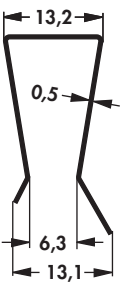
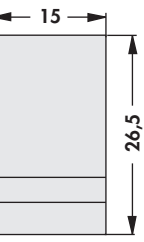
art. no.	for transistor-housing	plate thickness [mm]	holding force [N]	material			
THFA 1	TO 220	2	20	stainless steel			
THFA 2	TO 220	6.5	20	spring steel, corrosion protected			
THFA 3	TO 220	5.5	33	spring steel, corrosion protected			
THFA 4	TO 218/ TO 247	6.5	59	spring steel, corrosion protected			

A 117

Mica wafers

Lock-in retaining spring for transistors →

Heatsinks for PCB →

Mounting material for semiconduct. →

→ E 19

→ A 119 – 121

→ A 89 – 91

→ E 44 – 48

Thermal conductive material

Mounting parts for heatsinks

Thermal conductive paste

Technical introduction

→ E 2 – 5

→ E 49 – 50

→ E 21 – 22

→ A 2 – 8

Retaining springs for transistors

- universal lock-in retaining spring for types TO 218, TO 220, TO 247, TO 264 and various SIP-Multiwatt etc. transistor housings
- clip fastening also for power transistors without holes, MAX types etc.
- easy assembly and secure hold when using a special groove geometry in heatsinks, housing parts etc.
- optimal heat transfer between component and cooling element
- various spring clip shapes available for fastening the components (see sketch)
- the range of suitable heat sinks is continuously extended
- versions specifically designed to meet customers requirements on request

Installation

THFU 1

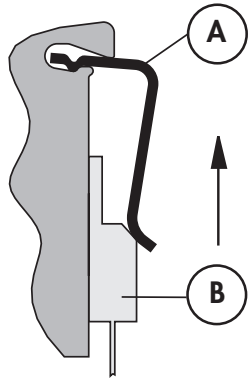

- insert the lock-in retaining spring for transistors THFU 1 (A) into the groove of the profile
- push transistor (B) below the spring into

THFU 2, THFU 3, THFU 4, THFU 5, THFU 6, THFU 7

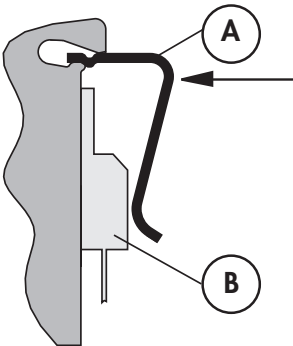

- place transistor (B) onto the mounting area
- press the lock-in retaining spring for transistors THFU 2 - 7 (A) into the groove of the profile (a suitable installation aid will facilitate pressing in)

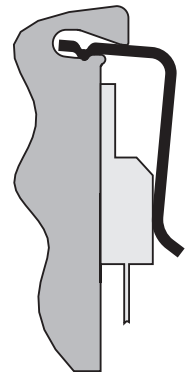



- Once in place, the spring will keep its position and fix the transistor with a high contact pressure on the installation surface (the spring remains in its position and it can neither be moved in a lengthwise direction nor fall it can out of the groove in a cross direction).



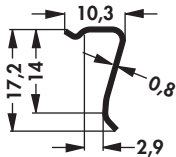
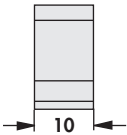

material:	stainless steel
material thickness:	0.8 mm

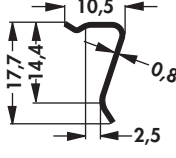
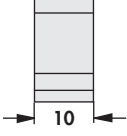
- | | | | |
|--|---------------|------------------------------|-------------|
| Mica wafers | → E 19 | Thermal conductive material | → E 2 - 5 |
| Lock-in retaining spring for transistors | → A 119 - 121 | Mounting parts for heatsinks | → E 49 - 50 |
| Heatsinks for PCB | → A 89 - 91 | Thermal conductive paste | → E 21 - 22 |
| Mounting material for semiconduct. | → E 44 - 48 | Technical introduction | → A 2 - 8 |

Lock-in retaining spring for transistors

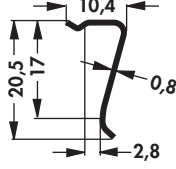
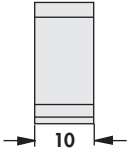

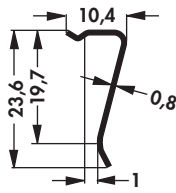
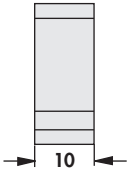
art. no.	for transistor-housing	suitable for heatsinks	spring force [N]	material				
THFU 1	TO 218/ TO 220/ TO 247/ TO 262/ TO 3 P/ SOT 199/ SOT 429	SK 480/ SK 481/ SK 482/ SK 483/ SK 487/ SK 489/ SK 490/ SK 492/ SK 495/ SK 499/ SK 512/ SK 514/ SK 573/ SK 574/ SK 575/ SK 576/ SK 589/ SK 593/ SK 617/ LAM 3 K/ LAM 4 K/ LAM 5 K/ LA 27 K	60 ±5	stainless steel				
	THFU 2	TO 218/ TO 220/ TO 247/ TO 262/ TO 3 P/ SOT 199/ SOT 429	SK 480/ SK 481/ SK 482/ SK 483/ SK 487/ SK 489/ SK 490/ SK 492/ SK 495/ SK 499/ SK 512/ SK 514/ SK 573/ SK 574/ SK 575/ SK 576/ SK 589/ SK 593/ SK 617/ LAM 3 K/ LAM 4 K/ LAM 5 K/ LA 27 K	60 ±5	stainless steel			

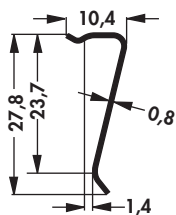
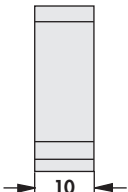
Lock-in retaining spring for transistors

art. no.	for transistor-housing	suitable for heatsinks	spring force [N]	material																	
THFU 3	TO 218/ TO 220/ TO 247/ TO 262/ TO 3 P/ SOT 199/ SOT 429	SK 480/ SK 481/ SK 482/ SK 483/ SK 487/ SK 489/ SK 490/ SK 492/ SK 495/ SK 499/ SK 514/ SK 573/ SK 574/ SK 575/ SK 576/ SK 589/ SK 593/ SK 617/ LAM 3 K/ LAM 4 K/ LAM 5 K/ LA 27 K	50 ±5	stainless steel																	
		THFU 4						TO 218/ TO 202/ TO 220/ TO 248/ TO 262/ TO 264/ TO 3 P/ SOT 199	SK 480/ SK 481/ SK 482/ SK 483/ SK 487/ SK 490/ SK 495/ SK 499/ SK 514/ SK 575/ SK 589/ SK 593/ SK 617/ LAM 5 K/ LA 27 K	32 ±5	stainless steel										
									THFU 5						TO 218/ TO 202/ TO 220/ TO 247/ TO 248/ TO 262/ TO 264/ TO 3 P/ SOT 199/ SOT 429	SK 490/ SK 589/ SK 617/ LAM 5 K/ LA 27 K	25 ±5	stainless steel			

Lock-in retaining spring for transistors

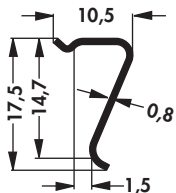
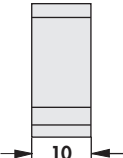
– THFU for transistors with low component height

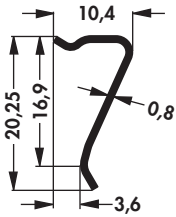
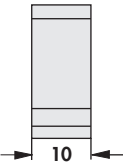
art. no.	for transistor-housing	suitable for heatsinks	spring force [N]	material		
THFU 6	TO 126/	SK 480/	65 ±5	stainless steel		 
	TO 218/	SK 481/				
	TO 220/	SK 482/				
	TO 225/	SK 483/				
	TO 247/	SK 487/				
	TO 248/	SK 489/				
	TO 251/	SK 490/				
	TO 3 P/	SK 492/				
	SOT 32	SK 495/				
		SK 499/				
		SK 512/				
		SK 514/				
		SK 573/				
		SK 574/				
		SK 575/				
		SK 576/				
		SK 589/				
		SK 593/				
		SK 617/				
		LAM 3 K/				
	LAM 4 K/					
	LAM 5 K/					
	LA 27 K					
THFU 7	eSIP	SK 480/	46 ±5	stainless steel		 
		SK 482/				
		SK 483/				
		SK 487/				
		SK 490/				
		SK 492/				
		SK 495/				
		SK 573/				
		SK 574/				
		SK 576/				
	LAM 3 K					

U-Extruded heatsinks

art. no.

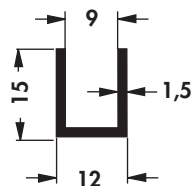
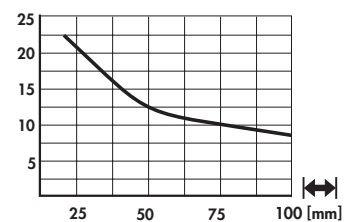
 R_{th} [K/W]

SK 12 ...

please indicate:

... $\left[\begin{array}{c} \text{---} \\ \text{---} \end{array} \right]$
1000 mm

art. no.

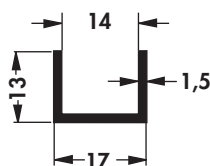
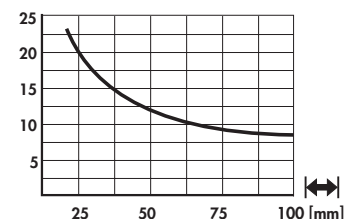
 R_{th} [K/W]

SK 13 ...

please indicate:

... $\left[\begin{array}{c} \text{---} \\ \text{---} \end{array} \right]$
25 35 mm

art. no.

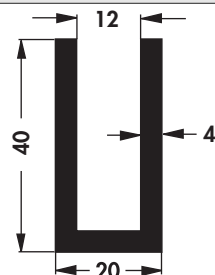
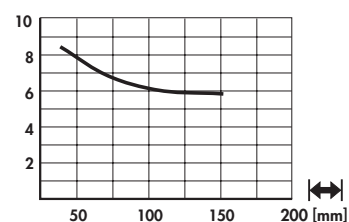
 R_{th} [K/W]

SK 115 ...

please indicate:

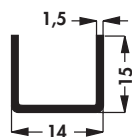
... $\left[\begin{array}{c} \text{---} \\ \text{---} \end{array} \right]$
37.5 50 1000 mm

UK 14 SA 220

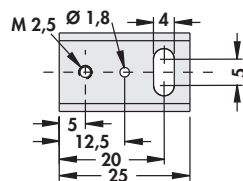

UK 14 SA 220 3,2

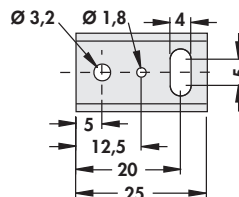

UK 14 SA M3

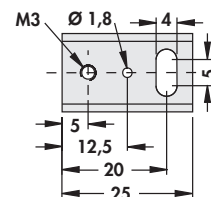

art. no.

 R_{th} [K/W]

Ø

UK 14 SA 220

20

TO 220

UK 14 SA 220 3,2

20

TO 220

UK 14 SA M3

20

TO 220

surface:

black anodised

A 123







Profiles for PCB components
Heatsink profile-overview
Heatsinks for PCB
Hole pattern

→ A 91
→ A 13 - 17
→ A 89 - 91
→ A 21

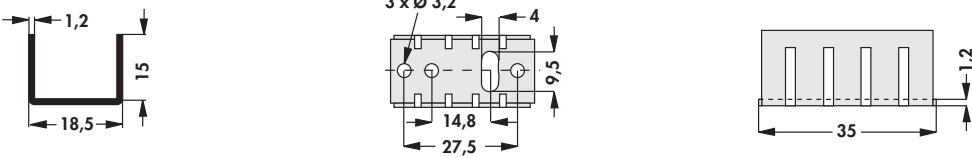
Profiles for PCB mounting
Extruded heatsinks
Retaining springs for transistors
Technical introduction

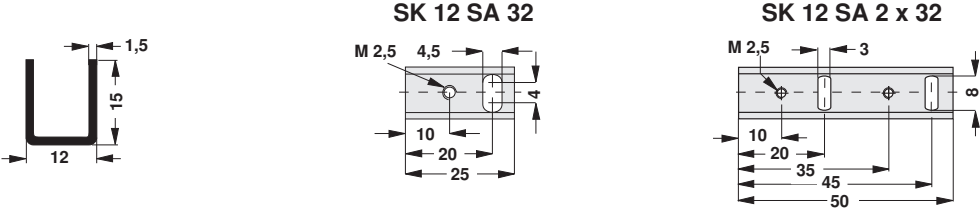

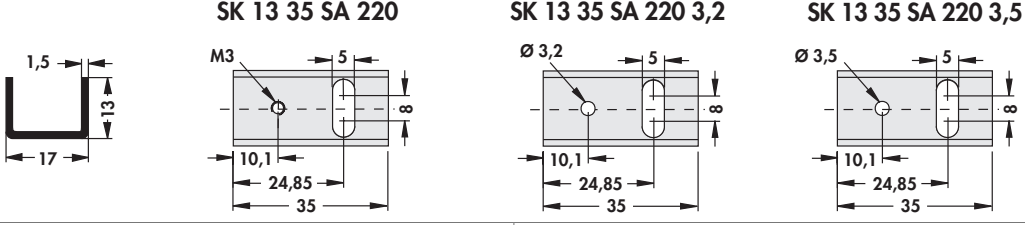

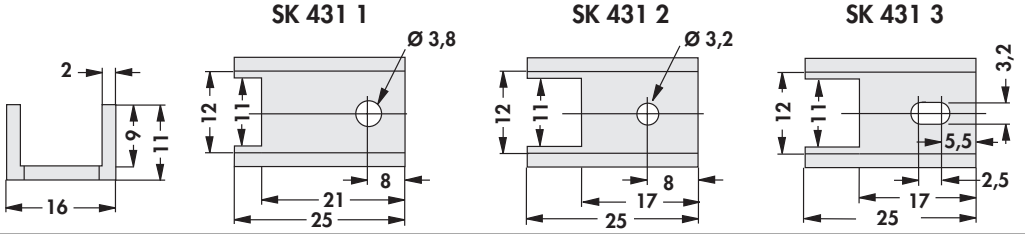
→ A 89 - 112
→ A 22 - 83
→ A 115 - 117
→ A 2 - 8

U-Extruded heatsinks

		
art. no.	R_{th} [K/W]	☐
ICK 35 SA	15	TO 220
		
art. no.	R_{th} [K/W]	☐
SK 12 SA 32	30	1xSOT 32
SK 12 SA 2 x 32	15	2xSOT 32
		
art. no.	R_{th} [K/W]	☐
SK 13 35 SA 220	17	TO 220
SK 13 35 SA 220 3,2	17	TO 220
SK 13 35 SA 220 3,5	17	TO 220
		
art. no.	R_{th} [K/W]	☐
SK 431 1	18	TO 220
SK 431 2	18	TO 220
SK 431 3	18	TO 220
surface:	black anodised	

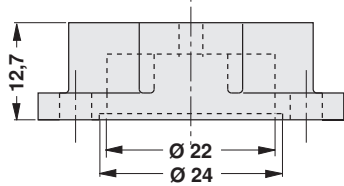
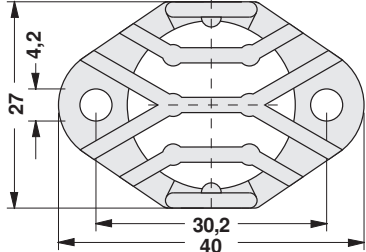
Die-cast heatsinks

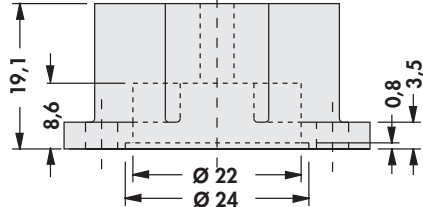
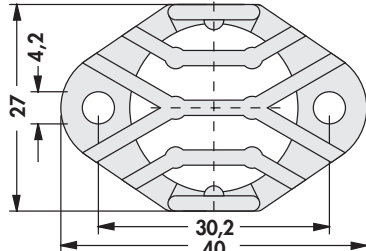
Setup heatsinks and angle for TO 3

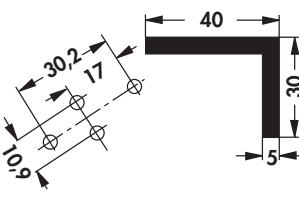
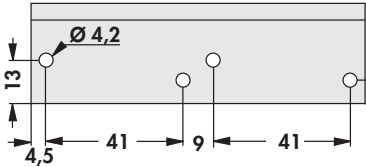
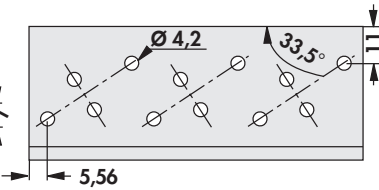





			
art. no.	↳ [mm]	R_{th} [K/W]	
AKK 127	27	14	
			
art. no.	↳ [mm]	R_{th} [K/W]	
AKK 191	27	12	
surface:	black lacquered		
material:	die-casting aluminium		
			
art. no.	↳ [mm]	R_{th} [K/W]	⊗
WP 4030 100 ...	100	3.7	—
WP 4030 100 3 ...	100	3.7	TO 3
please indicate:	... surface SA = black anodised AL = raw degreased aluminium		

socket: TF 3 2 → E 50

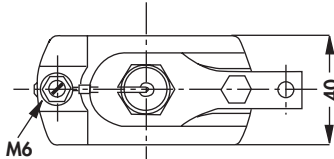
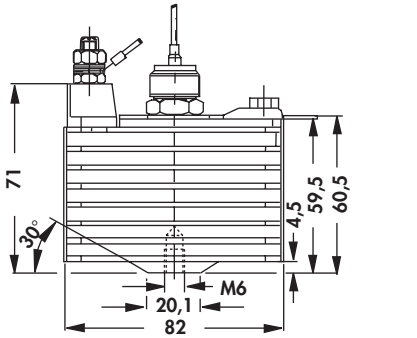
Die-cast heatsinks

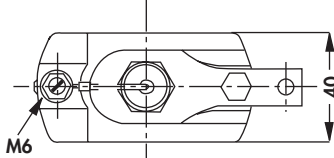
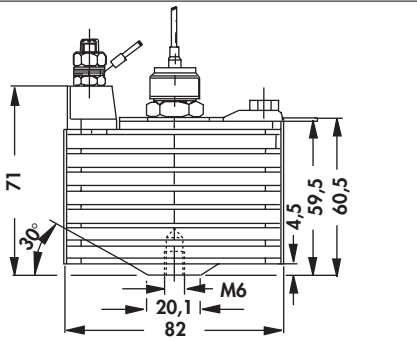
Die-cast acc. to german standard DIN 41882

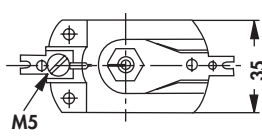
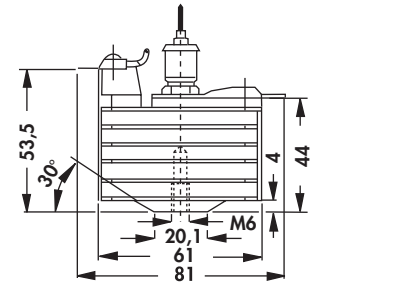
– other lengths and drillings on request

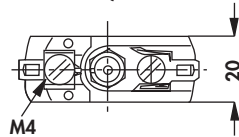
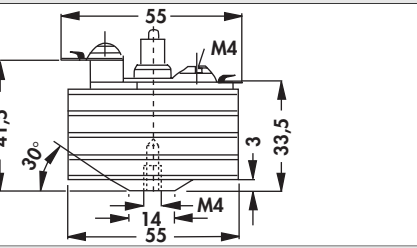
art. no. K 3 ...		<p style="text-align: center;">2,8 K/W</p> 	
for mounting use insulator: art. no.: IS 53			
please indicate: ... semiconductor retaining thread M 6, M 8, M 10, M 12, 1/4"-28 UNF			
art. no. K 3 T ...		<p style="text-align: center;">2,8 K/W</p> 	
Cathode lug insulator with an additional insulated connection (M 3). for mounting use insulator: art. no.: IS 53			
please indicate: ... semiconductor retaining thread M 6, M 8			
art. no. K 5 ...		<p style="text-align: center;">5 K/W</p> 	
for mounting use insulator: art. no.: IS 53			
please indicate: ... semiconductor retaining thread M 5, M 6, M 8, 1/4"-28 UNF			
art. no. K 9 ...		<p style="text-align: center;">9 K/W</p> 	
please indicate: ... semiconductor retaining thread M 4, M 5			
surface:	black lacquered		

Mounting for TO 3 angle
 Special profiles
 Standard aluminium profiles
 Heatsinks for PCB

→ A 125 Heatsinks for DC/DC converter
 → A 21 Profiles for lock-in fixing program
 → A 135 – 136 Heatsink profile-overview
 → A 89 – 112 Technical introduction

→ A 113 – 114
 → A 84 – 88
 → A 13 – 17
 → A 2 – 8

A 126

Die-cast heatsinks

Die-cast acc. to german standard DIN 41882

– other lengths and drillings on request

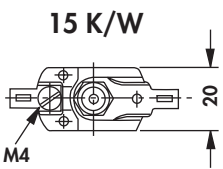
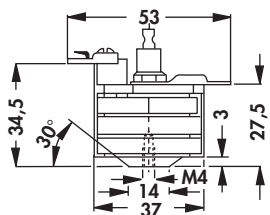

art. no. K 15 ...			
please indicate: ... semiconductor retaining thread M 4, M 5			
surface:		black lacquered	

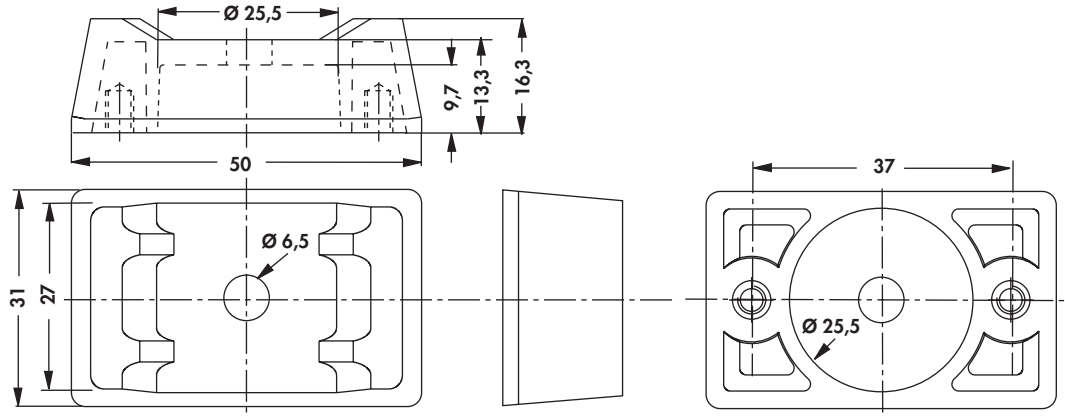
Mounting parts for heatsinks

art. no. IS 53			
---	---	--	--

Die-cast heatsinks

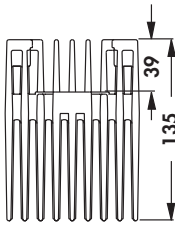
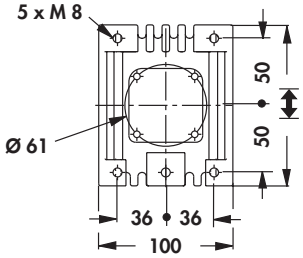
- completely milled mounting surface for semiconductors with square bottom plates
- the mounting surface can be equipped with threads for fastening semiconductors with screwed glands (semiconductor thread tapping)
- threads from M 4 to M 32 x 1.5 or 4 x threads for semiconductors with clamping plate mounting are available
- strap fastening thread M 8
- delivery without anode strap
- other lengths and drillings on request

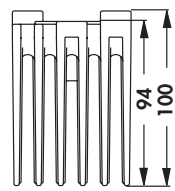
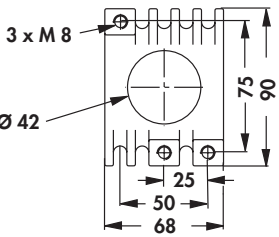
		
0,55 K/W		
art. no.	↳ [mm]	R_{th} [K/W]
K 0,55 ...	120	0.55
please indicate: ... semiconductor retaining thread M 12, M 24 x 1,5		
		
1,1 K/W		
art. no.	↳ [mm]	R_{th} [K/W]
K 1,1 ...	90	1.1
please indicate: ... semiconductor retaining thread M 8, M 12, M 16 x 1,5		
surface:	black lacquered	

Accessories

- anode end strap made of tin-plated cathode copper

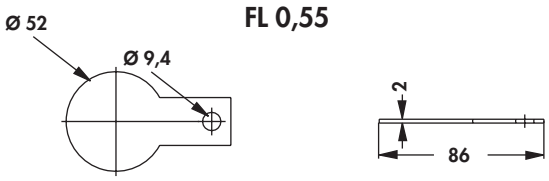
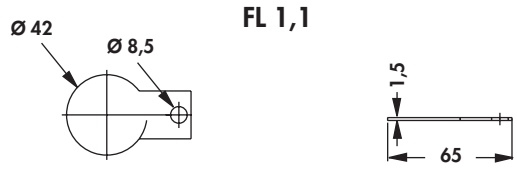
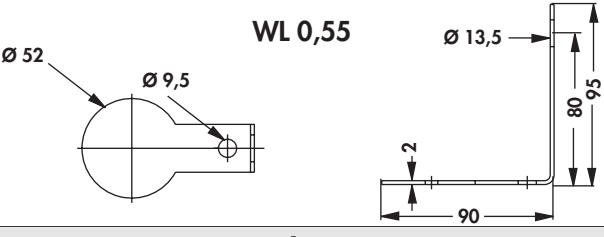
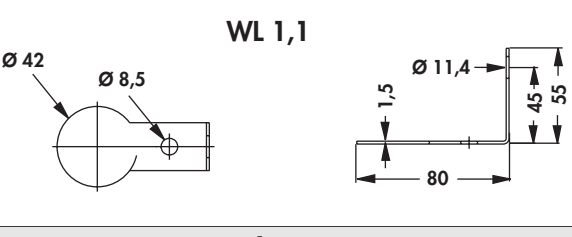
	FL 0,55		FL 1,1
art. no.		art. no.	
FL 0,55		FL 1,1	
	WL 0,55		WL 1,1
art. no.		art. no.	
WL 0,55		WL 1,1	

Mounting for TO 3 angle
Special profiles
Standard aluminium profiles
Heatsinks for PCB

→ A 125 Heatsinks for DC/DC converter
→ A 21 Profiles for lock-in fixing spring
→ A 135 - 136 Heatsink profile-overview
→ A 89 - 112 Technical introduction

→ A 113 - 114
→ A 84 - 88
→ A 13 - 17
→ A 2 - 8

A 128

Standard fin coolers for thermoelectrical elements

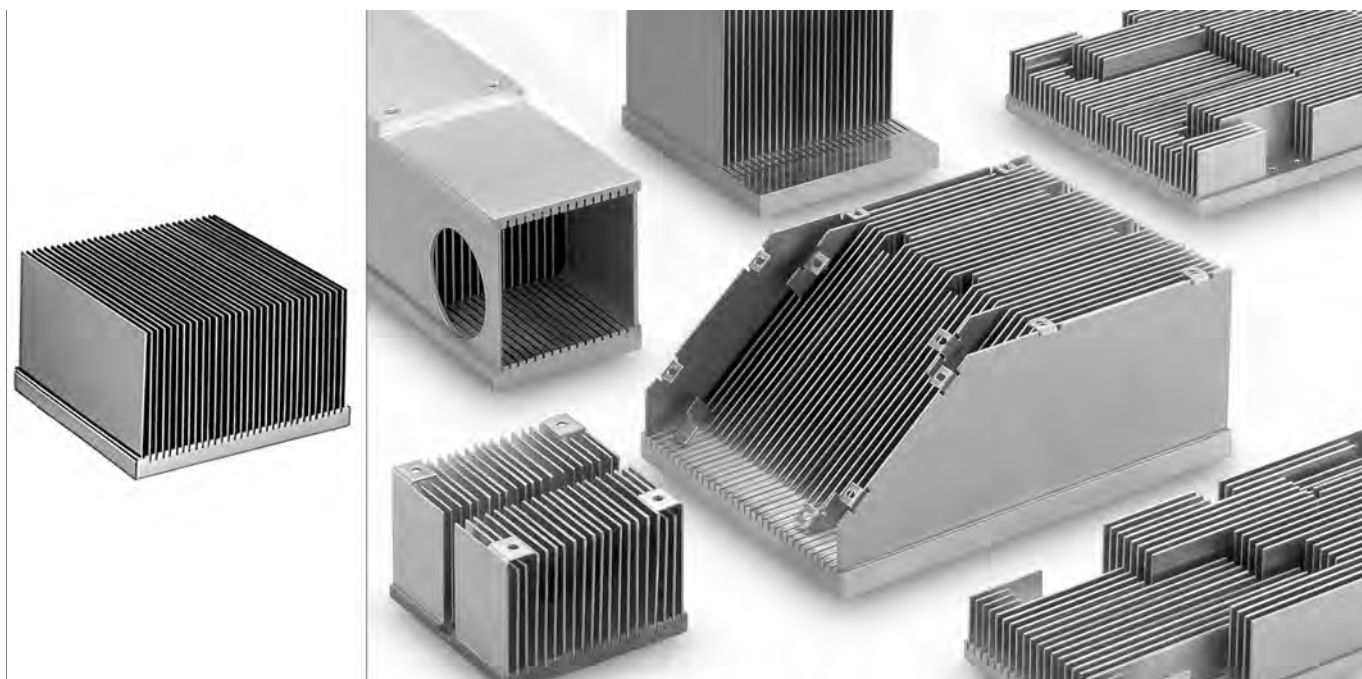

- fin coolers in special design
- especially suitable for thermoelectric elements (Peltier-elements) and similar power modules
- compact design with reduced volume
- large surface, therefore more efficient than extruded profiles
- particularly low heat resistance with forced air cooling
- ideally fitted fins from a heat engineer's point of view
- accurately flat milled surfaces
- very low roughness
- machining for module mounting according to drawing
- heat bridges (spacing bridges) on request
- lapped surface on request
- customer specific special design

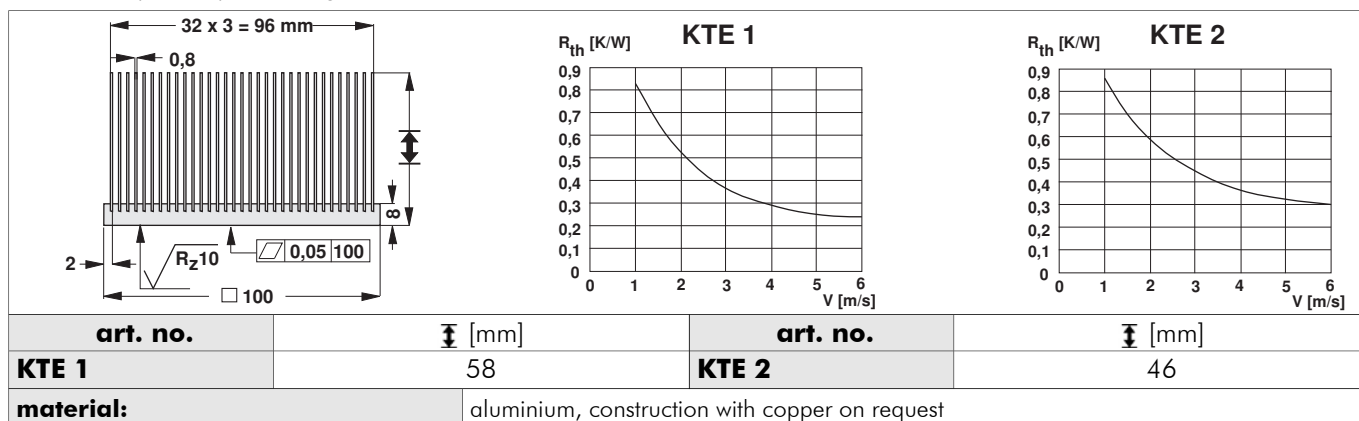

Fin coolers KTE/KTED custom design

KTE

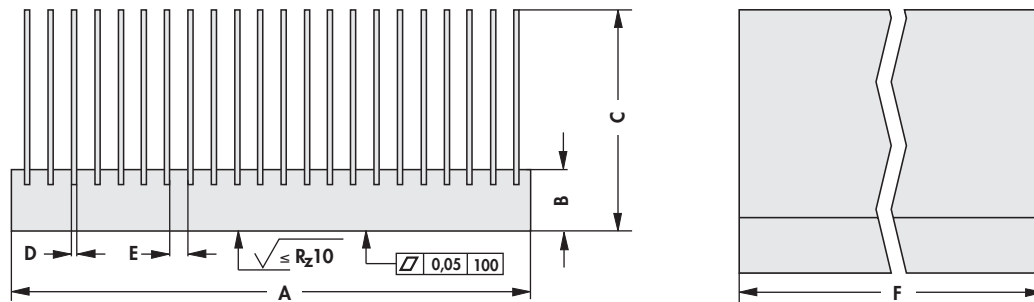

possible dimensions:

dimensions [mm]					
A	B	C	D	E	F
max. 400	max. 30	max. 150	0.8 / 1 / 1.5 / 2	min. 2	max. 400

please indicate with your order:

dimensions [mm]					
A	B	C	D	E	F

material: aluminium, construction with copper upon request

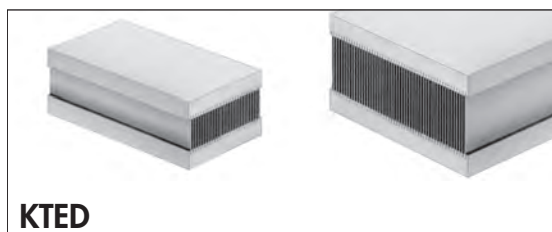

KTED

- fin coolers in special design
- for forced convection, thus particularly low thermal resistance
- two opposite bottom plates as mounting surfaces for power modules and similar
- mounting surfaces precisely flat milled
- compact design with reduced volume
- ideally fitted fins from a heat engineering point of view
- lapped finish on request
- additional machining according to customer's requirements
- fan versions on request
- special constructions to customer's indications

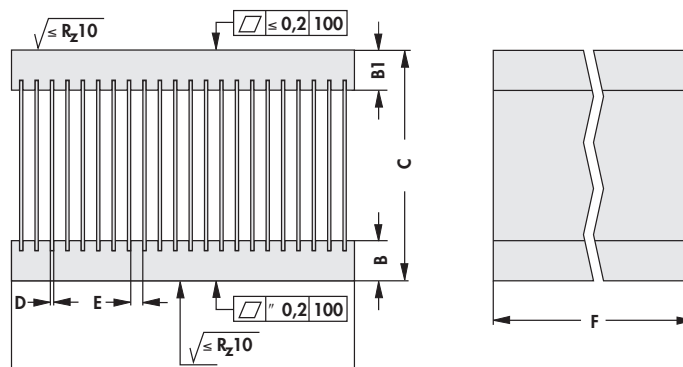

possible dimensions:

dimensions [mm]						
A	B	B 1	C	D	E	F
max. 400	max. 30	max. 30	max. 150	0.8 / 1 / 1.5 / 2	min. 2	max. 400

please indicate with your order:

dimensions [mm]						
A	B	B 1	C	D	E	F
max. 400	max. 30	max. 30	max. 150	0.8 / 1 / 1.5 / 2	min. 2	max. 400

material: aluminium, construction with copper upon request

Fluid coolers

Standard aluminium profiles
High capacity cooling aggregat.
Heatsink profile-overview

→ A 131 - 133 Drilling pattern for Solid State
→ A 135 - 136 Special heatsink design
→ D 26 - 29 Special profiles
→ A 13 - 17 Technical introduction

→ A 12
→ A 137 - 138
→ A 140
→ A 2 - 8

A 130

Fluid coolers for power modules

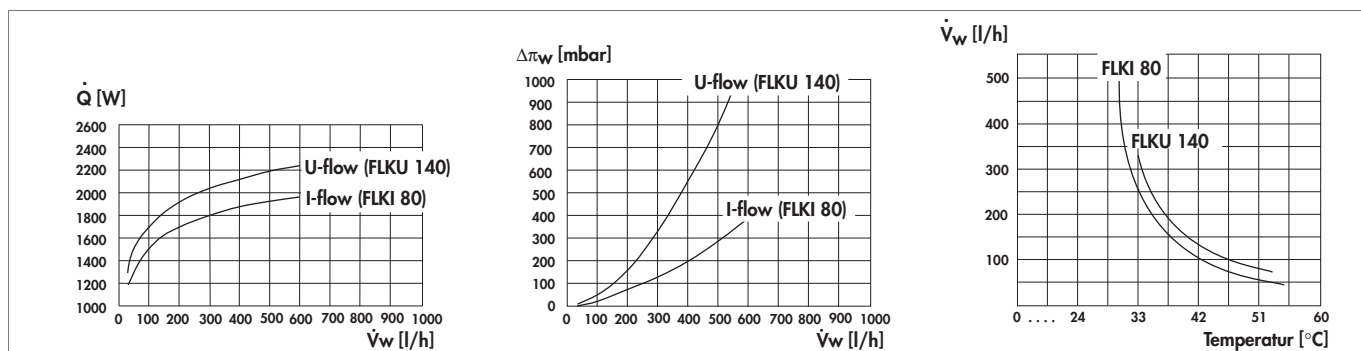





– water-glycol mixture (60/40); inlet temperature approx. 26 °C

Fluid cooler for dissipating large quantities of heat with low space requirement; **effective system to cool power modules**; suitable for water pH 6.5-8.5 with anticorrosives, as well as other fluids (eg. oil, alcohols, etc.); **compact design with internal fin structure for particularly good heat transfer to the fluid**; minimised flow pressure losses (see diagram); **operating pressure up to 2 bar possible**; thick base plate for optimum heat distribution and to secure the heat-emitting elements; **mounting flange for the cooler according to customer's instructions**; precisely face milled surface of component mounting area with very good flatness and low roughness depth; **dimensionally accurate adjustment to given mounting conditions**; connections using hole ports 12 mm in diameter with reinforcing seam to DIN 71550 or installation flange to customer's instructions; **I- or U-throughflow or multiple throughflow versions**; max. drilling depth in the base plate: 7 mm

To avoid corrosion in the water cooler the cooling fluid has to flow in a closed circuit and it has to contain 40-60% (preferred is 50%) anti-corrosive fluids for aluminium, if necessary with anti-freeze. For the choice and approval of the cooling fluid as well as for the possible consequences in the cooling circuit the user is the only liable person. Therefore we exclude any liability for damages caused by the choice or approval of the cooling fluids.

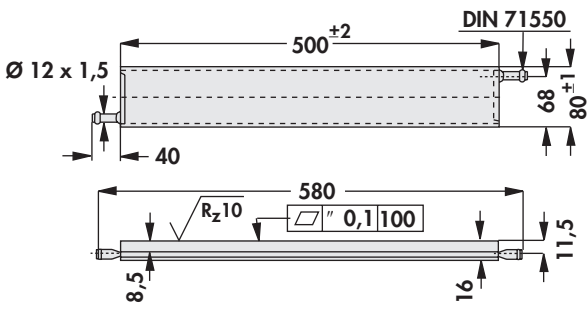
– dimensions and designs using customer's instructions

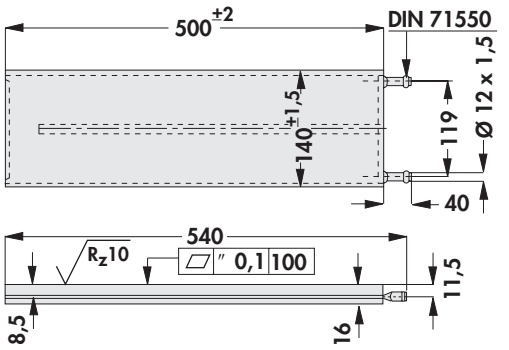
<p>art. no.</p>   <p>FLKI 80</p>	
<p>art. no.</p>   <p>FLKU 140</p>	
<p>material: EN AW 6060 (AlMgSi 0.5)</p>	

Fluid coolers for power modules

1 = FLKI 80 G 500 2 = FLKI 80 G 300 3 = FLKI 80 G 200

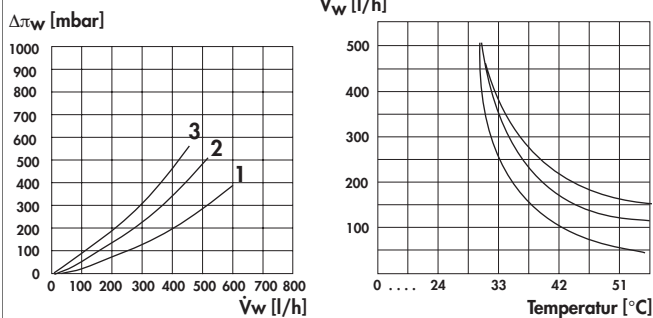

1 = FLKU 140 G 500 2 = FLKU 140 G 300 3 = FLKU 140 G 200

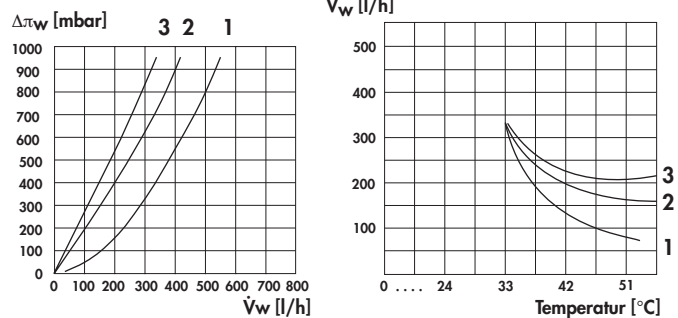



– water-glycol mixture (60/40); inlet temperature approx. 26 °C

Fluid cooler for dissipating large quantities of heat with low space requirement; **effective system to cool power modules**; suitable for water pH 6.5-8.5 with anticorrosive, as well as other fluids (eg. oil, alcohols, etc.); **compact design with internal fin structure for particularly good heat transfer to the fluid**; minimised flow pressure losses; **operating pressure up to 2 bar possible**; thick base plate for optimum heat distribution and to secure the heat-emitting elements; **mounting flange for the cooler according to customer's instructions**; precisely face milled surface of component mounting area with very good evenness and low roughness depth; **for power modules like IGBT-module, Thyristor-module, SCR diode module, bridge amplifiers and others**; dimensionally accurate adjustment to given mounting conditions; **connctions with thread muffle 1/8" or mounting flange according to customer's instructions**; l- or U-throughflow or multiple throughflow versions; **max. drilling depth in the base plate: 17 mm**

To avoid corrosion in the water cooler the cooling fluid has to flow in a closed circuit and it has to contain 40-60% (preferred is 50%) anti-corrosive fluids for aluminium, if necessary with anti-freeze. For the choice and approval of the cooling fluid as well as for the possible consequences in the cooling circuit the user is the only liable person. Therefore we exclude any liability for damages caused by the choice or approval of the cooling fluids.

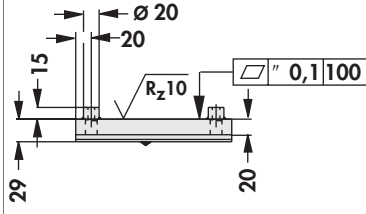
– dimensions and designs using customer's instructions

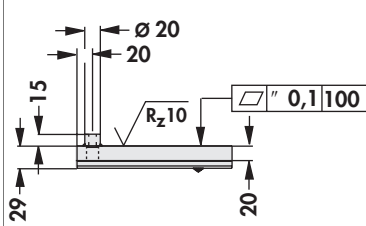
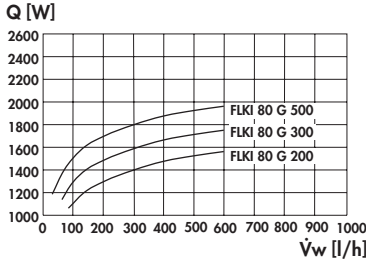
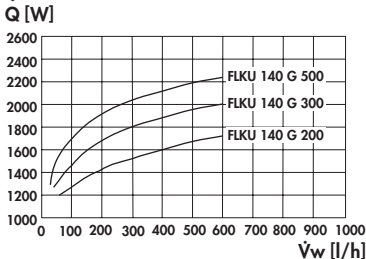
			
art. no.	 [mm]	art. no.	 [mm]
FLKI 80 G 200	200	FLKI 80 G 500	500
FLKI 80 G 300	300		
			
art. no.	 [mm]	art. no.	 [mm]
FLKU 140 G 200	200	FLKU 140 G 500	500
FLKU 140 G 300	300		
			
material:	EN AW 6060 (AlMgSi 0.5)		

Fin coolers
Cooling aggregates with axial fan
High capacity cooling aggregat.
Heatsink profile-overview

→ A 129
→ D 13 – 25
→ D 26 – 29
→ A 13 – 17
Special heatsink design
Special profiles
Hole pattern
Technical introduction

→ A 137 – 138
→ A 140
→ A 21
→ A 2 – 8

A 132

Standard aluminium profiles

- length, drilling and surface finishes to customer's instructions
- other standard profiles on request

U-profiles

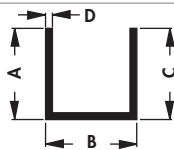

art. no.	A [mm]	B [mm]	C [mm]	D [mm]	art. no.	A [mm]	B [mm]	C [mm]	D [mm]
SU 02	20	40	20	2.5	SU 16	30	30	30	2.0
SU 03	20	40	20	2.0	SU 27	40	40	40	2.5
SU 05	30	20	30	2.0	SU 29	40	40	40	4.0
SU 09	20	20	20	1.5	SU 32	30	30	30	3.0
tolerances:			EN 755						
material:			EN AW 6060 (AlMgSi 0.5)						

flat profiles



art. no.	A [mm]	B [mm]	art. no.	A [mm]	B [mm]
SFP 005	40	15	SFP 058	40	8
SFP 006	30	8	SFP 060	80	8
SFP 007	40	5	SFP 067	30	15
SFP 016	70	15	SFP 074	70	10
SFP 028	40	10	SFP 076	60	30
SFP 029	30	10	SFP 079	90	100
SFP 037	55	10	SFP 090	120	15
SFP 046	25	5	SFP 100	100	15
SFP 054	50	10	SFP 106	40	20
SFP 057	115	100	SFP 112	100	25
tolerances:			EN 755		
material:			EN AW 6060 (AlMgSi 0.5)		

angled profile

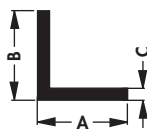

art. no.	A [mm]	B [mm]	C [mm]	art. no.	A [mm]	B [mm]	C [mm]
SWP 02	80	80	8	SWP 29	15	10	2
SWP 06	80	40	6	SWP 36	75	50	5
SWP 10	30	20	2	SWP 40	40	30	5
SWP 15	40	20	4	SWP 55	40	40	5
SWP 23	20	15	2	SWP 57	60	30	5
SWP 25	50	30	5				
tolerances:			EN 755				
material:			EN AW 6060 (AlMgSi 0.5)				

A 135

Hole pattern
Extruded heatsinks
Mounting for TO 3 angle
High capacity heatsinks

→ A 21
→ A 22 – 83
→ A 125 – 126
→ A 57 – 58

Construction parts made of aluminium
Heatsink as visual & decor-parts
Special profiles
Technical introduction

→ A 139
→ A 10
→ A 140
→ A 2 – 8

Standard aluminium profiles

quadrangular profile

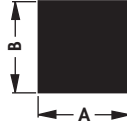

art. no.	A [mm]	B [mm]	art. no.	A [mm]	B [mm]
SVP 01	8	8	SVP 12	50	50
SVP 04	25	25	SVP 13	55	55
SVP 10	10	10			
tolerances:	EN 755				
material:	EN AW 6060 (AlMgSi 0.5)				

T-profile

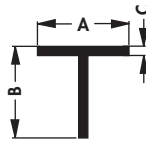

art. no.	A [mm]	B [mm]	C [mm]	art. no.	A [mm]	B [mm]	C [mm]
STP 4	60	60	6	STP 5	20	20	2
tolerances:	EN 755						
material:	EN AW 6060 (AlMgSi 0.5)						

Hole pattern

Extruded heatsinks

Mounting for TO 3 angle

High capacity heatsinks

→ A 21

→ A 22 – 83

→ A 125 – 126

→ A 57 – 58

Construction parts made of aluminium →

Heatsink as visual & decor-parts →

Special profiles →

Technical introduction →

A 139

→ A 10

→ A 140

→ A 2 – 8

A 136



Customer specified CNC treatments of cooling profiles

- latest CNC machining centres for highest quality demands
- profile treatments for seizes up to 1600 mm
- future orientated stockkeeping of the aluminium profiles in fully automated honeycomb warehouses
- batch size optimized production flow
- special profiles, modifications and surfaces according to your special demand

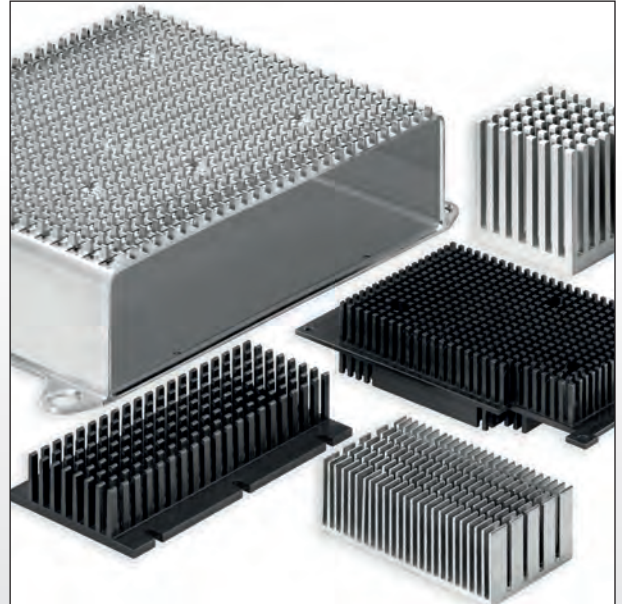

Streamlined omnidirectional fin geometrie

- free-standing cooling fingers for forced cooling
- incident flow of the heatsinks by means of fans from all sides (omnidirectional)
- no direction-oriented installation position
- fin spacings according to your demand
- special designs, treatments and versions according to customer's request

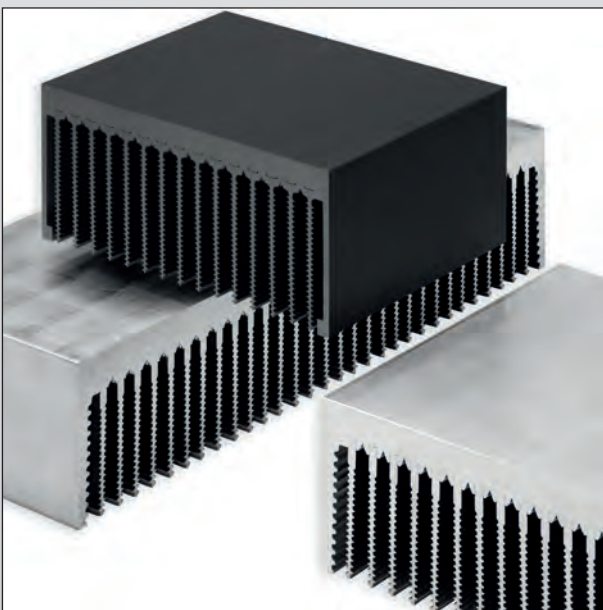

Extruded heatsinks with pressed-in fins

- for highest thermal dissipation losses
- channelled fin geometrie for increasing the surface
- thermotechnical optimized connection between fin and bottom plate
- deliverable in widths of 200 up to 750 mm
- customer specific versions and treatments



Precise milled flat surfaces

- very small depth of roughness and unevenness
- individually milled flat semi-conductor mounting surfaces for minimizing the heat-transmission resistances
- millings on the already anodized heatsinks
- protective foil avoid scratching of the high-quality mounting surface
- special designs according to customer's drawing



Surface labelling

- durable and high quality labeling by means of YAG-laser, silk screen-, pad- and digital printing
- print layout preparation by means of in-house repro department
- precise in contrast, precise engraved fonts and contours by means of CNC-controlled treatment systems
- labeling of aluminium, Plexiglas and plastics



Additional equipments

- fractional semi-conductor mounting surfaces made of copper for heat dissipation
- pressed-in or screwed distance sleeves made of metal and plastics
- threaded bolts with internal and external thread
- support rail mountings made of metal or plastics according to DIN EN 50022

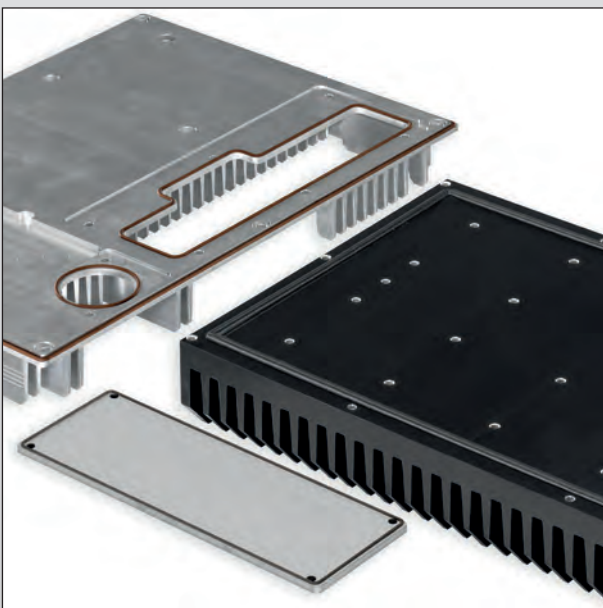

Heatsinks with integrated sealing

- foamed sealing applied on the profile as a permanent element of the heatsink
- also usable for front plates or milled parts
- groove filled or stacked
- permanently elastic and CFC-free
- adaption of the sealing properties to the specific application

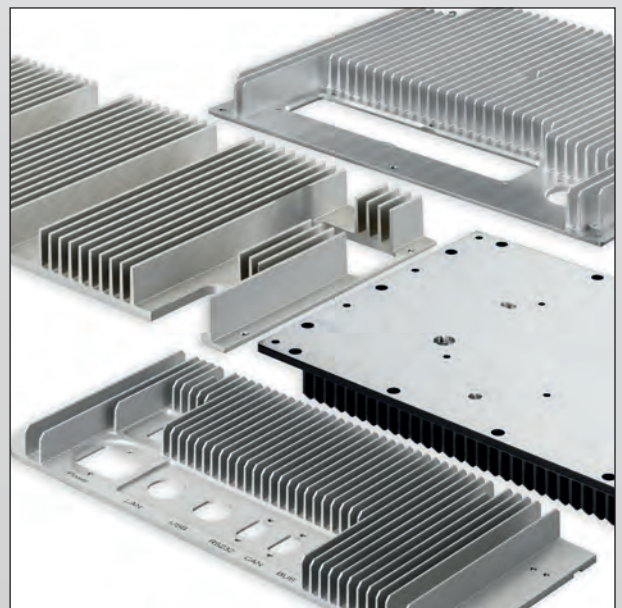

19" compliant CNC-treatment

- milled heatsink side or back panels for 19" cases, 19" plug in boxes, subracks and insert modules
- pressing in or welding of threaded bolts
- customer specified modifications, designs
- surfaces and printing upon request



Welded high performance heatsinks

- optimal fin geometry with channelled structure for free convection
- production of heatsink widths outside of the press-technical production possibilities
- removing of the welding line by means of precise milled flat surfaces
- individual surface design

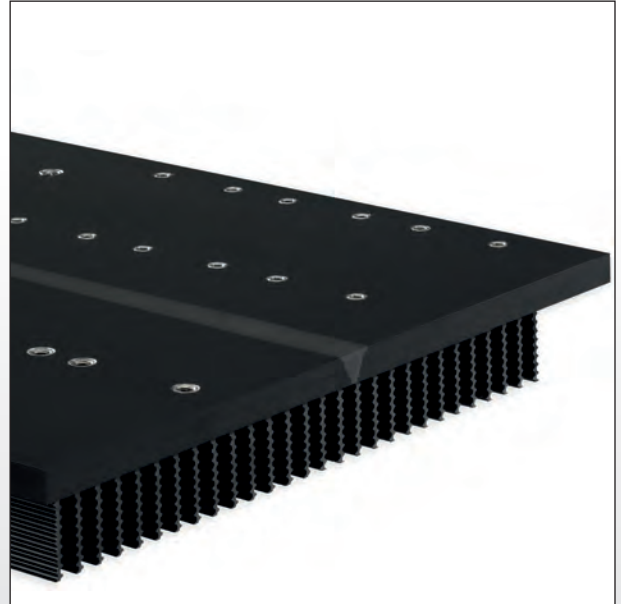

Welded heatsinks

- homogeneous connection of the materials by means of special welding methods
- welding on additional mounting levels which are situated diagonally to the pressing direction of the profiles
- production of prototypes
- application-based special designs and treatments according to your demand



Construction- and milled parts made of aluminium according to customer specifications

- precise milled contours and surfaces
- inserting of holes and cut-outs, cutting or milling of threads
- turning in of wire thread inserts for high- and wear-resistant threads
- simple data exchange by means of up to date CAD- / CAM-systems



Cases and contour milled parts made of aluminium

- customer specific cases and construction parts
- precise mechanical treatments for highest quality demands
- all requested surface designs
- modifications and versions, special requirements, treatments and designs according to your drawing specification

Special profiles

Whenever you cannot find the ideal solution for your problem from the wide range of standard extrusions on offer or a solution constitutes a compromise between the use of the space available and the weight, as long as the quantity is correct a special section is the answer.

Released from the dimensional restrictions of the standard profiles, special extrusions are tailored to your design requirements, and offer considerable benefits in terms of machining time and use of space.

Furthermore your calculation will be influenced positively by the optimised material use and shorter machining times. You can determine the combination of the desired thermal properties and the design element yourself, by the use of a special profile. We are not allowed to publish many of our customer-specific Profiles, because they are subject to „non disclosure agreements“. Therefore we only show some examples for customer profiles in the industry. All figures are illustrations. Changes reserved.

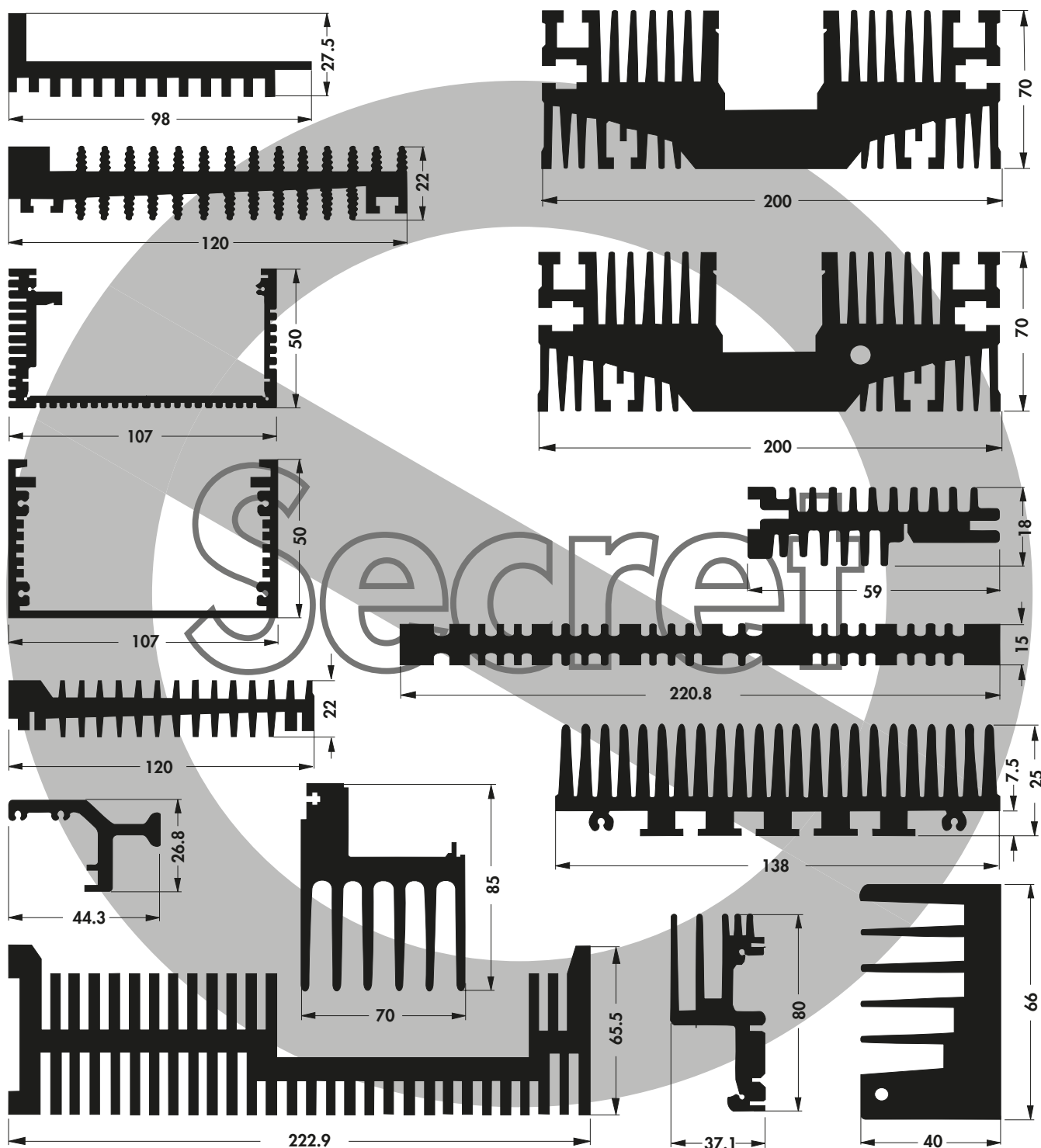

If required please send your request.

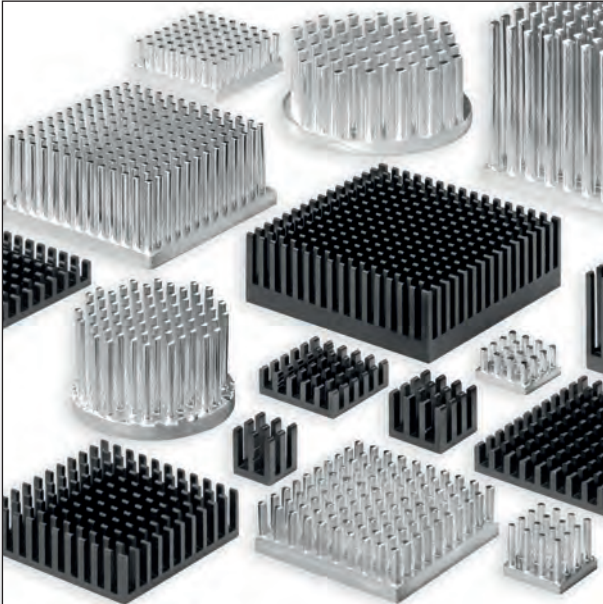

Round and pin heatsinks

- streamlined omnidirectional fin geometry
- excellent thermal conductivity due to special aluminium alloys
- suitable for free and forced convection
- no direction bounded installation position
- flat semiconductor mounting surfaces
- contour also as milled parts according to your demands



Heatsinks for LEDs

- various heatsink geometries adjusted to all current LED-types and light-engines
- star shaped heatsinks for the use as a LED-lamp housing
- LED mounting by means of screws, thermal conductive adhesive foil or thermal conductive glue
- customer specified versions with application based „thermal management“

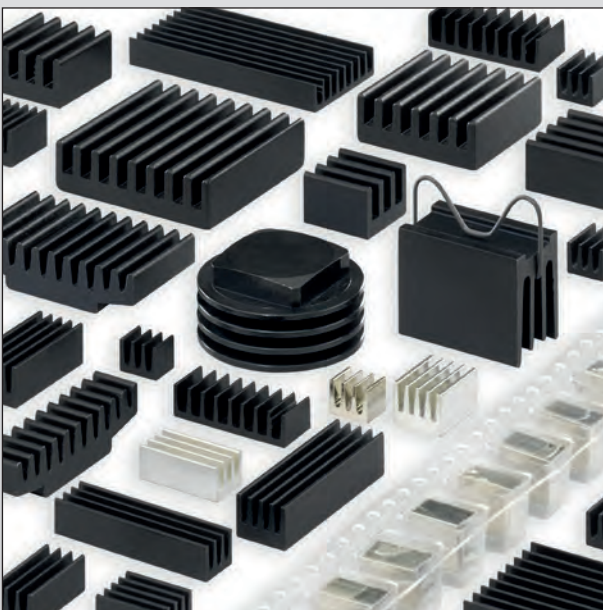

Heatsinks for all current PL CC, DIL-IC and SMD transistor types

- effective heat dissipation at a low profile and low weight
- direct mounting of the component by means of a double-sided adhesive thermal foil or glue
- solderable versions of the surface
- special packaging such as tape & reel, magazine or tray upon request

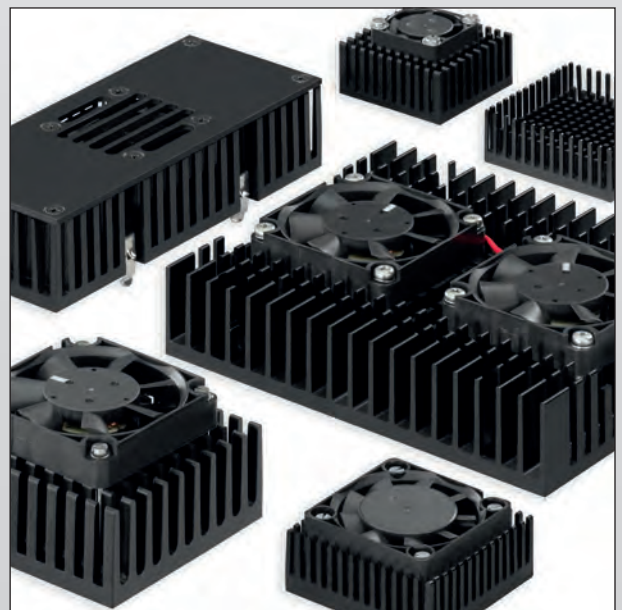

Heatsinks and coolers for processors

- passive and active product solutions
- effective heat dissipation due to optimal conception of fan and heatsink
- long lifetime and high operating safety due to high quality fans
- versions for screw, glue and clip mounting
- customer specific solutions and fans

Heatsinks for IC processor

art. no.	page	R_{th} [K/W]	dissipation loss [W]	way of fixation	socket	suitable for processor type
ICK PGA 6 x 6 x 14	B 11	20	6.4	therm. conductive foil/ therm. cond. adhesive	universal	universal
ICK PGA 8 x 8 x 12	B 11	14.8	8.1	therm. conductive foil/ therm. cond. adhesive	universal	universal
ICK PGA 9 x 9	B 11	14	3	therm. conductive foil/ therm. cond. adhesive	universal	universal
ICK PGA 11 x 11 x 8	B 11	16	7.5	therm. conductive foil/ therm. cond. adhesive	universal	universal
ICK PGA 11 x 11	B 11	10.9	4.5	therm. conductive foil/ therm. cond. adhesive	universal	universal
ICK PGA 11 x 11 x 12	B 12	12.3	3.9	therm. conductive foil/ therm. cond. adhesive	universal	universal
ICK PGA 14 x 14	B 12	10	4.9	therm. conductive foil/ therm. cond. adhesive	universal	universal
ICK PGA 14 x 14 x 10	B 12	10.5	11.2	therm. conductive foil/ therm. cond. adhesive	universal	universal
ICK PGA 14 x 14 x 14	B 12	9.6	12.5	therm. conductive foil/ therm. cond. adhesive	universal	universal
ICK PGA 14 x 14 x 12	B 12	9.8	5.3	therm. conductive foil/ therm. cond. adhesive	universal	universal
ICK PGA 15 x 15	B 12	9.4	5.9	therm. conductive foil/ therm. cond. adhesive	universal	universal
ICK PGA 16 x 16 x 8	B 13	14	4.9	therm. conductive foil/ therm. cond. adhesive	universal	universal
ICK PGA 16 x 16 x 10	B 13	10.5	12.9	therm. conductive foil/ therm. cond. adhesive	universal	universal
ICK PGA 16 x 16 x 12	B 13	9.3	6.2	therm. conductive foil/ therm. cond. adhesive	universal	universal
ICK PGA 17 x 17	B 13	8.6	6.9	therm. conductive foil/ therm. cond. adhesive	universal	universal
ICK PGA 17 x 17 x 8	B 13	13.2	5.2	therm. conductive foil/ therm. cond. adhesive	universal	universal
ICK PGA 17 x 17 x 12	B 13	9	6.5	therm. conductive foil/ therm. cond. adhesive	universal	universal
ICK PGA 18 x 18	B 14	8.4	7.2	therm. conductive foil/ therm. cond. adhesive	universal	universal
ICK PGA 19 x 19	B 14	8.6	7.6	therm. conductive foil/ therm. cond. adhesive	universal	universal
ICK PGA 19 x 19 x 12	B 14	9	6.9	therm. conductive foil/ therm. cond. adhesive	universal	universal
ICK PGA 20 x 20 x 10	B 14	8.5	15.1	therm. conductive foil/ therm. cond. adhesive	universal	universal
ICK PGA 20 x 20	B 14	7.6	8.3	therm. conductive foil/ therm. cond. adhesive	universal	universal
ICK PGA 20 x 20 K	B 15	7.6	8.3	fixing clamp	socket 7/ socket 370	IDT W2A/ AMD® K6-III/ AMD® K6-2/ MMX/ IDT C6/ Intel® Pentium®
ICK PGA 20 x 20 x 8	B 15	12	6.3	therm. conductive foil/ therm. cond. adhesive	universal	universal
ICK PGA 20 x 20 x 12	B 15	8	8.1	therm. conductive foil/ therm. cond. adhesive	universal	universal

- very good thermal efficiency
- aerodynamic omnidirectional fin geometry
- simple mounting by means of fixing clamp, thermal conductive adhesive film or thermal conductive glue
- customer specified designs, surfaces and modifications upon request

Heatsinks for IC processor

art. no.	page	R_{th} [K/W]	dissipation loss [W]	way of fixation	socket	suitable for processor type
ICK PGA 21 x 21	B 15	7	8.6	therm. conductive foil/ therm. cond. adhesive	universal	universal
ICK PGA 22 x 22	B 15	6.2	8.9	therm. conductive foil/ therm. cond. adhesive	universal	universal
ICK PGA 25 x 25	B 16	5	11.1	therm. conductive foil/ therm. cond. adhesive	universal	universal
ICK BGA 10 x 10	B 17	30	1.8	therm. conductive foil/ therm. cond. adhesive	universal	universal
ICK BGA 10 x 10 x 10	B 17	28.5	1.9	therm. conductive foil/ therm. cond. adhesive	universal	universal
ICK BGA 14 x 14	B 17	30	2.1	therm. conductive foil/ therm. cond. adhesive	universal	universal
ICK BGA 14 x 14 x 10	B 17	27.4	2.3	therm. conductive foil/ therm. cond. adhesive	universal	universal
ICK BGA 21 x 21	B 18	24.3	2.5	therm. conductive foil/ therm. cond. adhesive	universal	universal
ICK BGA 23 x 23	B 18	22.5	2.8	therm. conductive foil/ therm. cond. adhesive	universal	universal
ICK BGA 23 x 23 x 10	B 18	21.5	2.9	therm. conductive foil/ therm. cond. adhesive	universal	universal
ICK BGA 27 x 27	B 18	20	3.1	therm. conductive foil/ therm. cond. adhesive	universal	universal
ICK BGA 27 x 27 x 10	B 18	18.5	3.3	therm. conductive foil/ therm. cond. adhesive	universal	universal
ICK BGA 27 x 27 x 14	B 18	13.5	9.5	therm. conductive foil/ therm. cond. adhesive	universal	universal
ICK BGA 27 x 27 x 22	B 19	10.5	9.5	therm. conductive foil/ therm. cond. adhesive	universal	universal
ICK BGA 31 x 31	B 19	18.6	3.4	therm. conductive foil/ therm. cond. adhesive	universal	universal
ICK BGA 31 x 31 x 10	B 19	17	3.7	therm. conductive foil/ therm. cond. adhesive	universal	universal
ICK BGA 35 x 35	B 19	16.5	3.7	therm. conductive foil/ therm. cond. adhesive	universal	universal
ICK BGA 35 x 35 x 10	B 19	15.7	3.8	therm. conductive foil/ therm. cond. adhesive	universal	universal
ICK BGA 37 x 37 x 6	B 19	15.7	9.5	therm. conductive foil/ therm. cond. adhesive	universal	universal
ICK BGA 37 x 37 x 10	B 20	14	10.5	therm. conductive foil/ therm. cond. adhesive	universal	universal
ICK BGA 40 x 40	B 20	14.6	4.3	therm. conductive foil/ therm. cond. adhesive	universal	universal
ICK BGA 40 x 40 x 10	B 20	13.8	4.4	therm. conductive foil/ therm. cond. adhesive	universal	universal
ICK BGA 42,5 x 45	B 20	13.6	4.2	therm. conductive foil/ therm. cond. adhesive	universal	universal
ICK S 10 x 10 x 6,5	B 21	25	2.5	therm. conductive foil/ therm. cond. adhesive	universal	universal
ICK S 10 x 10 x 10	B 21	23.75	2.6	therm. conductive foil/ therm. cond. adhesive	universal	universal
ICK S 10 x 10 x 12,5	B 21	22.5	2.8	therm. conductive foil/ therm. cond. adhesive	universal	universal
ICK S 10 x 10 x 18,5	B 22	21.75	3	therm. conductive foil/ therm. cond. adhesive	universal	universal

B 3

- very good thermal efficiency
- aerodynamic imnidirectional fin geometry
- simple mounting by means of fixing clamp, thermal conductive adhesive film or thermal conductive glue
- customer specified designs, surfaces and modifications upon request

Heatsinks for IC processor

art. no.	page	R_{th} [K/W]	dissipation loss [W]	way of fixation	socket	suitable for processor type
ICK S 14 x 14 x 6,5	B 22	9	5	therm. conductive foil/ therm. cond. adhesive	universal	universal
ICK S 14 x 14 x 10	B 22	8.8	5.1	therm. conductive foil/ therm. cond. adhesive	universal	universal
ICK S 14 x 14 x 12,5	B 22	8.1	5.4	therm. conductive foil/ therm. cond. adhesive	universal	universal
ICK S 14 x 14 x 18,5	B 22	7.9	5.6	therm. conductive foil/ therm. cond. adhesive	universal	universal
ICK S 17 x 17 x 15	B 22	8.36	5.95	therm. conductive foil/ therm. cond. adhesive	universal	universal
ICK S 17 x 17 x 20	B 23	7.89	6.3	therm. conductive foil/ therm. cond. adhesive	universal	universal
ICK S 18 x 18 x 6,5	B 23	7	7.7	therm. conductive foil/ therm. cond. adhesive	universal	universal
ICK S 18 x 18 x 10	B 23	6.8	8	therm. conductive foil/ therm. cond. adhesive	universal	universal
ICK S 22 x 22 x 10	B 23	5.9	8.5	therm. conductive foil/ therm. cond. adhesive	universal	universal
ICK S 22 x 22 x 18,5	B 23	5	10	therm. conductive foil/ therm. cond. adhesive	universal	universal
ICK S 25 x 25 x 6,5	B 23	5.8	12.9	therm. conductive foil/ therm. cond. adhesive	universal	universal
ICK S 25 x 25 x 12,5	B 24	5.3	14.1	therm. conductive foil/ therm. cond. adhesive	universal	universal
ICK S 25 x 25 x 18,5	B 24	5.2	14.4	therm. conductive foil/ therm. cond. adhesive	universal	universal
ICK S 29 x 29 x 10	B 24	5.7	13.1	therm. conductive foil/ therm. cond. adhesive	universal	universal
ICK S 29 x 29 x 20	B 24	3.7	20.2	therm. conductive foil/ therm. cond. adhesive	universal	universal
ICK S 29 x 29 x 30	B 24	2.9	21	therm. conductive foil/ therm. cond. adhesive	universal	universal
ICK S 32 x 32 x 10	B 24	5.4	13.8	therm. conductive foil/ therm. cond. adhesive	universal	universal
ICK S 32 x 32 x 20	B 25	3.7	20.4	therm. conductive foil/ therm. cond. adhesive	universal	universal
ICK S 36 x 36 x 10	B 25	4.7	16	therm. conductive foil/ therm. cond. adhesive	universal	universal
ICK S 36 x 36 x 15	B 25	3.9	19.2	therm. conductive foil/ therm. cond. adhesive	universal	universal
ICK S 36 x 36 x 20	B 25	3.2	22	therm. conductive foil/ therm. cond. adhesive	universal	universal
ICK S 36 x 36 x 30	B 25	2.5	23.4	therm. conductive foil/ therm. cond. adhesive	universal	universal
ICK S 40 x 40 x 10	B 25	4.6	16.3	therm. conductive foil/ therm. cond. adhesive	universal	universal
ICK S 40 x 40 x 20	B 26	3.5	21.4	therm. conductive foil/ therm. cond. adhesive	universal	universal
ICK S 40 x 40 x 25	B 26	3.1	23.7	therm. conductive foil/ therm. cond. adhesive	universal	universal
ICK S 45 x 45 x 10	B 26	4.7	16	therm. conductive foil/ therm. cond. adhesive	universal	universal
ICK S 45 x 45 x 20	B 26	4.4	17	therm. conductive foil/ therm. cond. adhesive	universal	universal

- very good thermal efficiency
- aerodynamic omnidirectional fin geometry
- simple mounting by means of fixing clamp, thermal conductive adhesive film or thermal conductive glue
- customer specified designs, surfaces and modifications upon request

Heatsinks for IC processor

art. no.	page	R_{th} [K/W]	dissipation loss [W]	way of fixation	socket	suitable for processor type
ICK S 50 x 50 x 20	B 26	2.7	27.7	therm. conductive foil/ therm. cond. adhesive	universal	universal
ICK S 50 x 50 x 25	B 26	2.4	31.2	therm. conductive foil/ therm. cond. adhesive	universal	universal
ICK S 50 x 50 x 40	B 27	6.05	13.5	therm. conductive foil/ therm. cond. adhesive	universal	universal
ICK S 50 x 50 x 50	B 27	4.05	14.32	therm. conductive foil/ therm. cond. adhesive	universal	universal
ICK S 98 x 98 x 30	B 27	2.4	35	therm. conductive foil/ therm. cond. adhesive	universal	universal
ICK S 98 x 98 x 45	B 27	3.5	42	therm. conductive foil/ therm. cond. adhesive	universal	universal
ICK S D 12 x 12 x 7,5	B 28	10.85	4.6	therm. conductive foil/ therm. cond. adhesive	universal	universal
ICK S D 18 x 12 x 7,5	B 28	9	5.4	therm. conductive foil/ therm. cond. adhesive	universal	universal
ICK S D 24 x 18 x 7,5	B 28	8.5	5.85	therm. conductive foil/ therm. cond. adhesive	universal	universal
ICK S D 98 x 98 x 10	B 28	4.88	10.25	therm. conductive foil/ therm. cond. adhesive	universal	universal
ICK S R 28,5 x 6,5	B 29	5.82	15.6	therm. conductive foil/ therm. cond. adhesive	universal	universal
ICK S R 28,5 x 10	B 29	5.65	16	therm. conductive foil/ therm. cond. adhesive	universal	universal
ICK S R 28,5 x 12,5	B 29	5.53	16.3	therm. conductive foil/ therm. cond. adhesive	universal	universal
ICK S R 28,5 x 18,5	B 29	4.25	20.2	therm. conductive foil/ therm. cond. adhesive	universal	universal
ICK S R 32,5 x 10	B 29	5.54	9	therm. conductive foil/ therm. cond. adhesive	universal	universal
ICK S R 32,5 x 20	B 29	5.6	8.9	therm. conductive foil/ therm. cond. adhesive	universal	universal
ICK S R 32,5 x 30	B 30	4.2	11	therm. conductive foil/ therm. cond. adhesive	universal	universal
ICK S R 32,5 x 40	B 30	3.2	15	therm. conductive foil/ therm. cond. adhesive	universal	universal
ICK S R 32,5 x 50	B 30	2.7	18	therm. conductive foil/ therm. cond. adhesive	universal	universal
ICK S R 36,5 x 20	B 30	6.41	18	therm. conductive foil/ therm. cond. adhesive	universal	universal
ICK S R 40 x 10	B 30	11.04	8.4	therm. conductive foil/ therm. cond. adhesive	universal	universal
ICK S R 40 x 20	B 30	10.32	8.8	therm. conductive foil/ therm. cond. adhesive	universal	universal
ICK S R A 40 x 20	B 31	11.62	8.2	therm. conductive foil/ therm. cond. adhesive	universal	universal
ICK S R 40 x 30	B 31	9.77	16	therm. conductive foil/ therm. cond. adhesive	universal	universal
ICK S R 40 x 50	B 31	2	25	therm. conductive foil/ therm. cond. adhesive	universal	universal
ICK S R 45 x 30	B 31	8	9.2	therm. conductive foil/ therm. cond. adhesive	universal	universal
ICK S R 45 x 45	B 31	6	9.2	therm. conductive foil/ therm. cond. adhesive	universal	universal

B 5

- very good thermal efficiency
- aerodynamic imnidirectional fin geometry
- simple mounting by means of fixing clamp, thermal conductive adhesive film or thermal conductive glue
- customer specified designs, surfaces and modifications upon request

Heatsinks for IC processor

art. no.	page	R_{th} [K/W]	dissipation loss [W]	way of fixation	socket	suitable for processor type
ICK S R 50 x 10	B 31	5.28	9.5	therm. conductive foil/ therm. cond. adhesive	universal	universal
ICK S R 50 x 20	B 32	8.55	9.8	therm. conductive foil/ therm. cond. adhesive	universal	universal
ICK S R 50 x 30	B 32	8.26	10	therm. conductive foil/ therm. cond. adhesive	universal	universal
ICK S R 50 x 45	B 32	6.32	12.7	therm. conductive foil/ therm. cond. adhesive	universal	universal
ICK S R 54 x 20	B 32	8.11	10.2	therm. conductive foil/ therm. cond. adhesive	universal	universal
ICK S R 54 x 30	B 32	6.95	11.57	therm. conductive foil/ therm. cond. adhesive	universal	universal
ICK S R 54 x 45	B 33	5.37	15.2	therm. conductive foil/ therm. cond. adhesive	universal	universal
ICK S R 70 x 30	B 33	1.8	27	therm. conductive foil/ therm. cond. adhesive	universal	universal
ICK S R 70 x 50	B 33	1.5	33	therm. conductive foil/ therm. cond. adhesive	universal	universal
ICK S R 85 x 30	B 33	2	25	therm. conductive foil/ therm. cond. adhesive	universal	universal
ICK S R 85 x 45	B 33	1.8	27	therm. conductive foil/ therm. cond. adhesive	universal	universal
ICK S R 98 x 30	B 34	1.65	30	therm. conductive foil/ therm. cond. adhesive	universal	universal
ICK S R 98 x 50	B 34	1.4	35	therm. conductive foil/ therm. cond. adhesive	universal	universal
ICK LED R 23,5 x 14	B 35	18.58	6.5	therm. conductive foil/ therm. cond. adhesive	universal	universal
ICK LED R 23,5 x 14 G	B 35	19.16	6.3	therm. conductive foil/ therm. cond. adhesive	universal	universal
ICK LED R 27 x 10	B 35	17.69	6.7	therm. conductive foil/ therm. cond. adhesive	universal	universal
ICK LED R 27 x 10 G	B 35	18.24	6.6	therm. conductive foil/ therm. cond. adhesive	universal	universal
ICK LED R 28 x 15	B 35	15.24	7.8	therm. conductive foil/ therm. cond. adhesive	universal	universal
ICK LED R 28 x 15 G	B 36	15.72	7.6	therm. conductive foil/ therm. cond. adhesive	universal	universal
ICK LED R 29 x 11,5	B 36	17.26	8.2	therm. conductive foil/ therm. cond. adhesive	universal	universal
ICK LED R 29 x 11,5 G	B 36	17.8	8	therm. conductive foil/ therm. cond. adhesive	universal	universal
ICK LED R 32 x 14	B 36	15.23	7.8	therm. conductive foil/ therm. cond. adhesive	universal	universal
ICK LED R 32 x 14 G	B 36	15.23	7.6	therm. conductive foil/ therm. cond. adhesive	universal	universal
ICK LED R 33 x 10	B 36	17.6	6.8	therm. conductive foil/ therm. cond. adhesive	universal	universal
ICK LED R 33 x 10 G	B 36	18.15	6.6	therm. conductive foil/ therm. cond. adhesive	universal	universal
ICK LED R 33 x 16,5	B 37	13.87	8.5	therm. conductive foil/ therm. cond. adhesive	universal	universal
ICK LED R 33 x 16,5 G	B 37	14.3	8.3	therm. conductive foil/ therm. cond. adhesive	universal	universal

- very good thermal efficiency
- aerodynamic omnidirectional fin geometry
- simple mounting by means of fixing clamp, thermal conductive adhesive film or thermal conductive glue
- customer specified designs, surfaces and modifications upon request

Heatsinks for IC processor

art. no.	page	R_{th} [K/W]	dissipation loss [W]	way of fixation	socket	suitable for processor type
ICK LED R 35 x 10	B 37	16.9	9.35	therm. conductive foil/ therm. cond. adhesive	universal	universal
ICK LED R 35 x 10 G	B 37	17.5	9.2	therm. conductive foil/ therm. cond. adhesive	universal	universal
ICK LED R 36 x 12	B 37	12.88	10	therm. conductive foil/ therm. cond. adhesive	universal	universal
ICK LED R 36 x 12 G	B 37	13.28	8.9	therm. conductive foil/ therm. cond. adhesive	universal	universal
ICK LED R 40 x 10	B 37	12.28	9.45	therm. conductive foil/ therm. cond. adhesive	universal	universal
ICK LED R 40 x 10 G	B 38	12.66	9.3	therm. conductive foil/ therm. cond. adhesive	universal	universal
ICK LED R 40 x 27	B 38	9.41	12.1	therm. conductive foil/ therm. cond. adhesive	universal	universal
ICK LED R 40 x 27 G	B 38	9.71	11.9	therm. conductive foil/ therm. cond. adhesive	universal	universal
ICK LED R 45,7 x 16,5	B 38	10.46	11.05	therm. conductive foil/ therm. cond. adhesive	universal	universal
ICK LED R 45,7 x 16,5 G	B 38	10.49	10.8	therm. conductive foil/ therm. cond. adhesive	universal	universal
ICK LED R 50 x 10	B 38	10.57	10.5	therm. conductive foil/ therm. cond. adhesive	universal	universal
ICK LED R 50 x 10 G	B 39	10.9	10.3	therm. conductive foil/ therm. cond. adhesive	universal	universal
ICK LED R 50,8 x 16,5	B 39	10.17	11.1	therm. conductive foil/ therm. cond. adhesive	universal	universal
ICK LED R 50,8 x 16,5 G	B 39	10.49	10.9	therm. conductive foil/ therm. cond. adhesive	universal	universal
ICK LED R 54 x 20	B 39	9.48	12.1	therm. conductive foil/ therm. cond. adhesive	universal	universal
ICK LED R 54 x 20 G	B 39	9.78	11.9	therm. conductive foil/ therm. cond. adhesive	universal	universal
ICK LED R 66 x 40	B 39	3.2	21	therm. conductive foil/ therm. cond. adhesive	universal	universal
ICK LED R 75 x 10	B 40	5.2	12.1	therm. conductive foil/ therm. cond. adhesive	universal	universal
ICK LED R 84 x 40	B 40	2.5	14.5	therm. conductive foil/ therm. cond. adhesive	universal	universal
ICK LED R 100 x 40	B 40	2	27	therm. conductive foil/ therm. cond. adhesive	universal	universal
ICK LED R 160 x 40	B 40	1.4	42	therm. conductive foil/ therm. cond. adhesive	universal	universal
ICK LED R 200 x 40	B 41	1	51	therm. conductive foil/ therm. cond. adhesive	universal	universal

B 7

- very good thermal efficiency
- aerodynamic imnidirectional fin geometry
- simple mounting by means of fixing clamp, thermal conductive adhesive film or thermal conductive glue
- customer specified designs, surfaces and modifications upon request

Fan coolers for IC processor

art. no.	page	R_{th} [K/W]	dissipation loss [W]	way of fixation	socket	suitable for processor type
LA LED 40 x 30	B 49	1.4	35	therm. conductive foil/ therm. cond. adhesive	universal	universal
LA LED 50 x 20	B 49	1.25	40	therm. conductive foil/ therm. cond. adhesive	universal	universal
LA LED 50 x 45	B 49	0.9	50	therm. conductive foil/ therm. cond. adhesive	universal	universal
ICK PPC 51	B 56	8.1	14	screw fastening		Power PC
ICK PEN 3 XE	B 56	2	31.3	screw fastening	Slot 2	Intel® Pentium® III-Xeon™ Slot II Format
ICK PEN 3 XE 1	B 56	1.8	33.6	screw fastening	Slot 2	Intel® Pentium® III-Xeon™ Slot II Format
ICK EM 25	B 56	3.9	20.4	screw fastening		Q7 Board
ICK PEN 38 F	B 57	4	15.1	therm. conductive foil	socket 7/ socket 370	AMD® K6-III/ IDT W2A/ MMX/ IDT C6/ Intel® Pentium®/ AMD® K6-2
ICK PEN 38 W	B 57	4	15.1	therm. cond. adhesive	socket 7/ socket 370	AMD® K6-III/ IDT W2A/ MMX/ IDT C6/ Intel® Pentium®/ AMD® K6-2
ICK PEN 45 W	B 57	3.5	21	therm. cond. adhesive	socket 7/ socket 370	AMD® K6-III/ IDT W2A/ MMX/ IDT C6/ Intel® Pentium®/ AMD® K6-2
ICK PRO 40 W	B 57	2.7	22	therm. cond. adhesive	socket 8	Intel® Pentium® PRO
ICK PEN 3 FC	B 57	3.5	22	fixing clamp	socket 7/ socket 370	Intel® Pentium® III FC PGA (Mendocino, Coppermine)
LA ICK 15 x 15 F 05	B 58	2.3	22.2	therm. conductive foil	universal	universal
LA ICK 15 x 15 F 12	B 58	2.3	22.2	therm. conductive foil	universal	universal
LA ICK 17 x 17 F 12	B 58	1.6	35.8	therm. conductive foil	universal	universal
LA ICK 17 x 17 F 12 A	B 58	1.6	35.8	therm. conductive foil	universal	universal
LA ICK 17 x 17 W 05	B 58	1.6	35.8	therm. cond. adhesive	universal	universal
LA ICK 17 x 17 W 12	B 58	1.6	35.8	therm. cond. adhesive	universal	universal
LA ICK 18 x 18 F 12	B 58	1.5	41.7	therm. conductive foil	universal	universal
LA ICK 18 x 18 W 12	B 58	1.5	41.7	therm. cond. adhesive	universal	universal
LA ICK 21 x 21 F 05	B 58	1.4	46.3	therm. conductive foil	universal	universal
LA ICK 21 x 21 F 12	B 58	1.4	46.3	therm. conductive foil	universal	universal
LA ICK 21 x 21 W 05	B 58	1.4	46.3	therm. cond. adhesive	universal	universal
LA ICK 21 x 21 W 12	B 58	1.4	46.3	therm. cond. adhesive	universal	universal

- high-quality industrial design
- compact design with high mechanical stability
- fan with doubled ball bearing axis
- optimal thermotechnical design of fan and heatsink

Fan coolers for IC processor

art. no.	page	R_{th} [K/W]	dissipation loss [W]	way of fixation	socket	suitable for processor type
LA ICK PEN 8 F 05	B 59	2.5	23.4	therm. conductive foil	socket 7/ socket 370	AMD® K6-III/ IDT W2A/ Cyrix MII and similar/ MMX/ IDT C6/ Intel® Pentium®/ AMD® K6-2
LA ICK PEN 8 F 12	B 59	2.5	23.4	therm. conductive foil	socket 7/ socket 370	AMD® K6-III/ IDT W2A/ Cyrix MII and similar/ MMX/ IDT C6/ Intel® Pentium®/ AMD® K6-2
LA ICK PEN 8 W 05	B 59	2.5	23.4	therm. cond. adhesive	socket 7/ socket 370	AMD® K6-III/ IDT W2A/ Cyrix MII and similar/ MMX/ IDT C6/ Intel® Pentium®/ AMD® K6-2
LA ICK PEN 8 W 12	B 59	2.5	23.4	therm. cond. adhesive	socket 7/ socket 370	AMD® K6-III/ IDT W2A/ Cyrix MII and similar/ MMX/ IDT C6/ Intel® Pentium®/ AMD® K6-2
LA ICK PEN 16 K 12	B 59	1.2	51.1	fixing clamp	socket 7/ socket 370	AMD® K6-III/ IDT W2A/ Cyrix MII and similar/ MMX/ IDT C6/ Intel® Pentium®/ AMD® K6-2
LA ICK PEN 16 W 12	B 59	1.2	51.1	therm. cond. adhesive	socket 7/ socket 370	AMD® K6-III/ IDT W2A/ Cyrix MII and similar/ MMX/ IDT C6/ Intel® Pentium®/ AMD® K6-2
LA ICK PEN 16 W 12 A	B 59	1.2	51.1	therm. cond. adhesive	socket 7/ socket 370	AMD® K6-III/ IDT W2A/ Cyrix MII and similar/ MMX/ IDT C6/ Intel® Pentium®/ AMD® K6-2

Fan coolers for IC processor

art. no.	page	R_{th} [K/W]	dissipation loss [W]	way of fixation	socket	suitable for processor type
LA ICK PEN 18 W 12	B 59	1.6	38.6	therm. cond. adhesive	socket 7/ socket 370	AMD® K6-III/ IDT W2A/ Cyrix MII and similar/ MMX/ IDT C6/ Intel® Pentium®/ AMD® K6-2
LA ICK PEN 38 W 12	B 59	1.1	53.6	therm. cond. adhesive	socket 7/ socket 370	AMD® K6-III/ IDT W2A/ Cyrix MII and similar/ MMX/ IDT C6/ Intel® Pentium®/ AMD® K6-2
LA ICK PRO 25 F 12	B 59	0.97	60	therm. conductive foil	socket 8	Intel® Pentium® PRO
LA ICK PEN 2 K 12	B 60	1.2	58		Slot A/ Slot 1	Intel® Pentium® II/ AMD® Athlon®
LA ICK PEN 3 XE	B 60	0.8	61.8	screw fastening	Slot 2	Intel® Pentium® III-Xeon™
LA ICK PEN 4 1 K	B 60	0.6	85	fixing clamp	socket 463/ socket 423	Intel® Pentium® IV

- high-quality industrial design
- compact design with high mechanical stability
- fan with doubled ball bearing axis
- optimal thermotechnical design of fan and heatsink

Heatsinks for PGA



- double-sided adhesive thermal conductive foil **WLF ...** → E 7
- **surface:** black anodised

<p>art. no.</p> <p>ICK PGA 6 x 6 x 14 WLF ... 14 x 14</p>		
<p>art. no.</p> <p>ICK PGA 8 x 8 x 12 WLF ... 23 x 23</p>		
<p>art. no.</p> <p>ICK PGA 9 x 9 WLF ... 24 x 24</p>		
<p>art. no.</p> <p>ICK PGA 11 x 11 x 8 WLF ... 24 x 27</p>		
<p>art. no.</p> <p>ICK PGA 11 x 11 WLF ... 24 x 27</p>		

B 11







Mounts
Heatsinks for PLCC
Thermal conductive paste
Thermal conductive glue

→ E 44 – 48
→ B 52
→ E 21 – 24
→ E 23 – 24

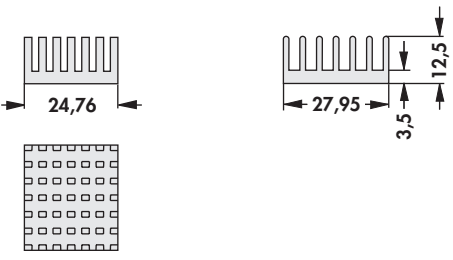
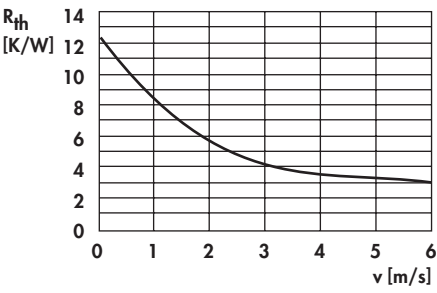
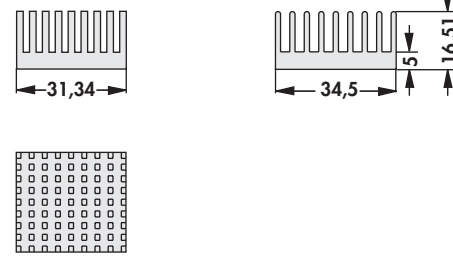
Pin heatsinks for IC
SMD-heatsinks
Heatsinks for PGA
Technical introduction

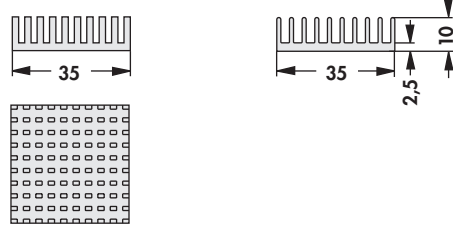
→ B 21 – 27
→ B 53 – 54
→ B 11 – 16
→ A 2 – 8

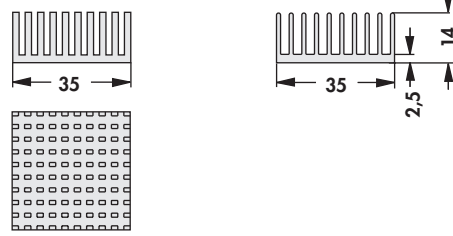
Heatsinks for PGA

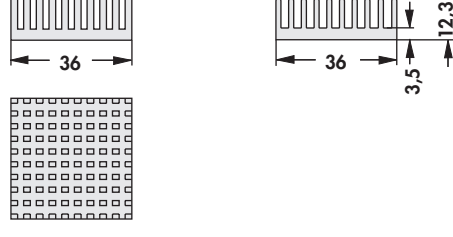
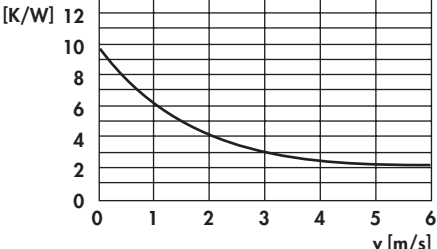
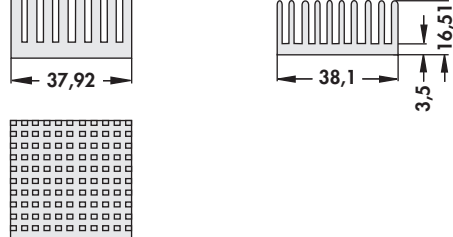
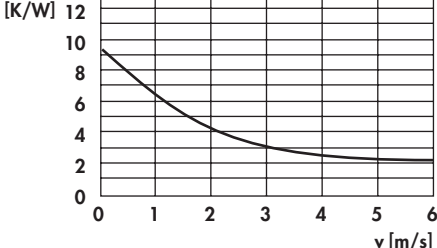
<p>art. no.</p> <p>ICK PGA 11 x 11 x 12 WLF ... 24 x 27</p>		
<p>art. no.</p> <p>ICK PGA 14 x 14 WLF ... 31 x 34</p>		
<p>art. no.</p> <p>ICK PGA 14 x 14 x 10 WLF ... 35 x 35</p>		
<p>art. no.</p> <p>ICK PGA 14 x 14 x 14 WLF ... 35 x 35</p>		
<p>art. no.</p> <p>ICK PGA 14 x 14 x 12 WLF ... 36 x 36</p>		
<p>art. no.</p> <p>ICK PGA 15 x 15 WLF ... 37 x 37</p>		

Mounts
Heatsinks for PLCC
Thermal conductive paste
Thermal conductive glue

→ E 44 – 48
→ B 52
→ E 21 – 24
→ E 23 – 24

Pin heatsinks for IC
SMD-heatsinks
Heatsinks for PGA
Technical introduction

→ B 21 – 27
→ B 53 – 54
→ B 11 – 16
→ A 2 – 8

Heatsinks for PGA

A

B

C

D

E

F

G

H

I

K

L

M

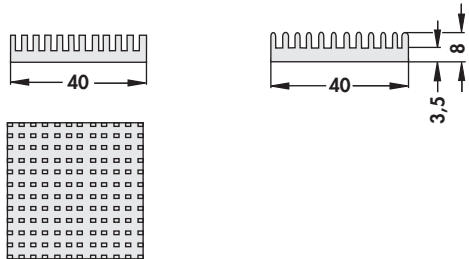
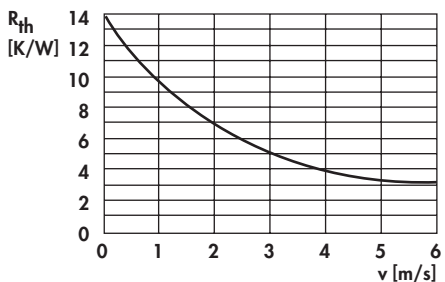
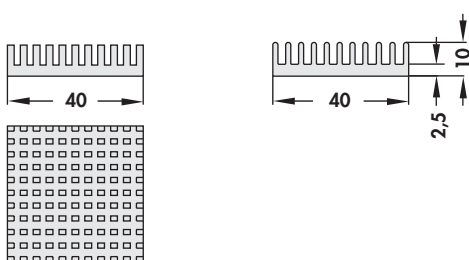
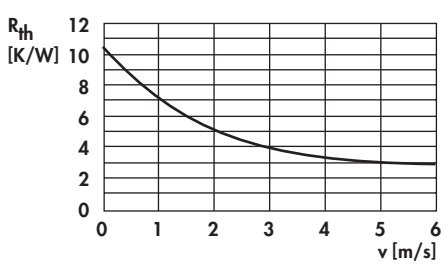
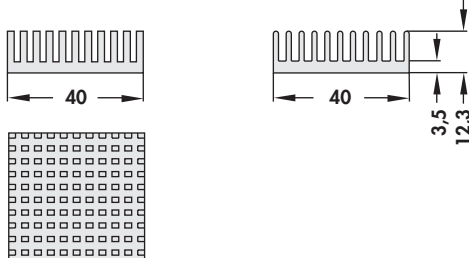
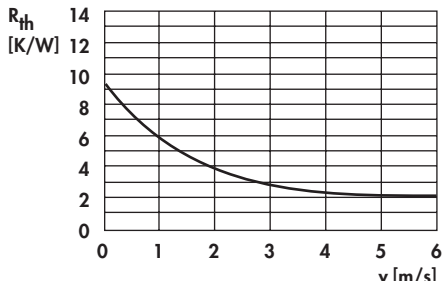
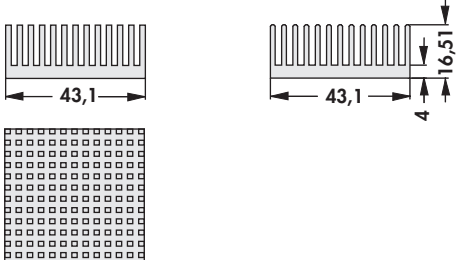
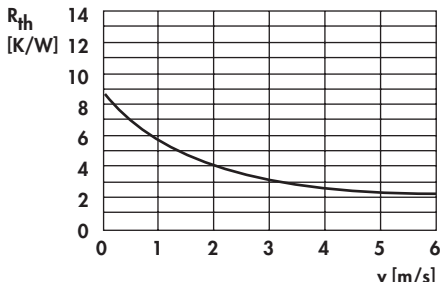
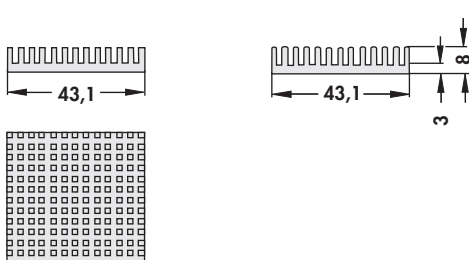
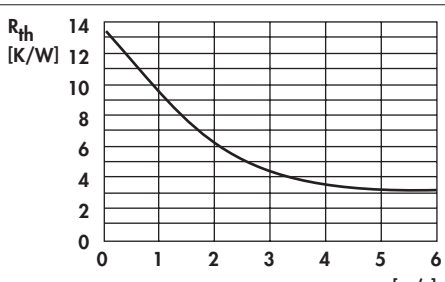
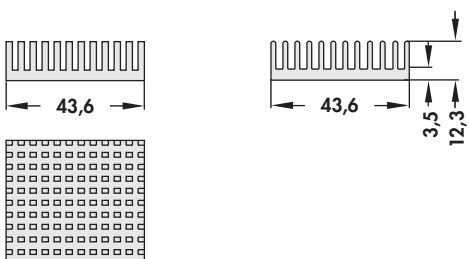
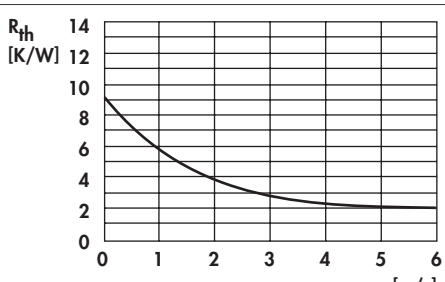
<p>art. no.</p> <p>ICK PGA 16 x 16 x 8 WLF ... 40 x 40</p>		
<p>art. no.</p> <p>ICK PGA 16 x 16 x 10 WLF ... 40 x 40</p>		
<p>art. no.</p> <p>ICK PGA 16 x 16 x 12 WLF ... 40 x 40</p>		
<p>art. no.</p> <p>ICK PGA 17 x 17 WLF ... 43 x 43</p>		
<p>art. no.</p> <p>ICK PGA 17 x 17 x 8 WLF ... 43 x 43</p>		
<p>art. no.</p> <p>ICK PGA 17 x 17 x 12 WLF ... 43 x 43</p>		

B 13

Mounts
Heatsinks for PLCC
Thermal conductive paste
Thermal conductive glue

→ E 44 – 48
→ B 52
→ E 21 – 24
→ E 23 – 24

Pin heatsinks for IC
SMD-heatsinks
Heatsinks for PGA
Technical introduction

→ B 21 – 27
→ B 53 – 54
→ B 11 – 16
→ A 2 – 8

N

Heatsinks for PGA

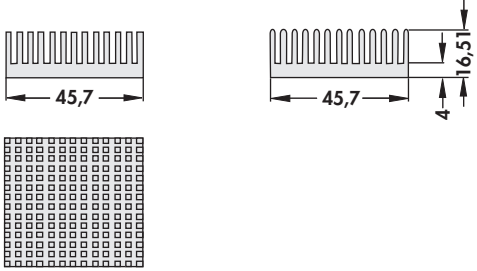
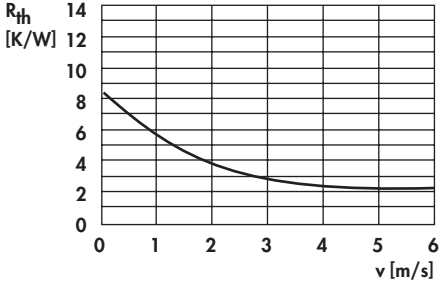
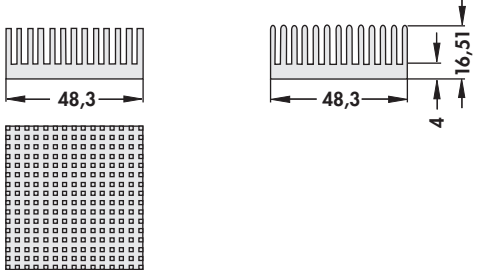
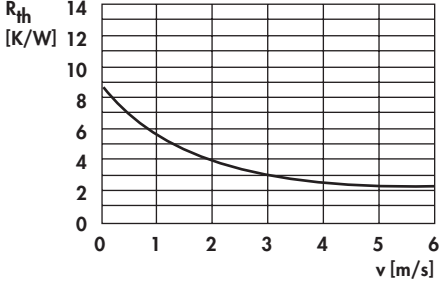
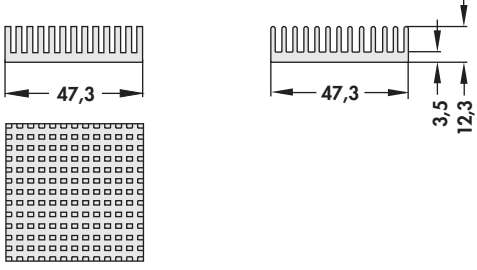
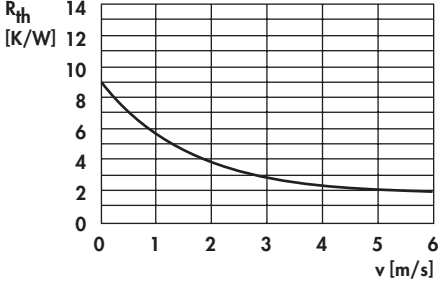
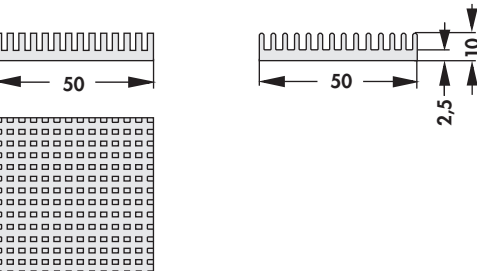
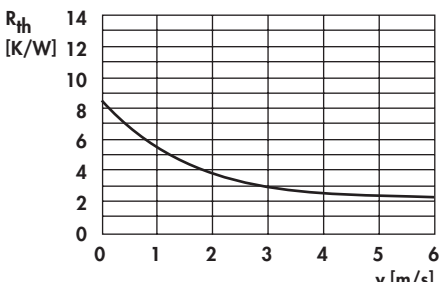
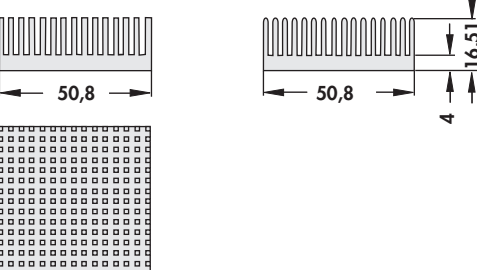
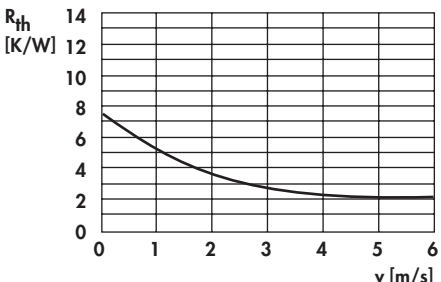
<p>art. no.</p> <p>ICK PGA 18 x 18 WLF ... 45 x 45</p>		
<p>art. no.</p> <p>ICK PGA 19 x 19 WLF ... 48 x 48</p>		
<p>art. no.</p> <p>ICK PGA 19 x 19 x 12 WLF ... 47 x 47</p>		
<p>art. no.</p> <p>ICK PGA 20 x 20 x 10 WLF ... 48 x 48</p>		
<p>art. no.</p> <p>ICK PGA 20 x 20 WLF ... 50 x 50</p>		

Mounts → E 44 – 48
 Heatsinks for PLCC → B 52
 Thermal conductive paste → E 21 – 24
 Thermal conductive glue → E 23 – 24

Pin heatsinks for IC → B 21 – 27
 SMD-heatsinks → B 53 – 54
 Heatsinks for PGA → B 11 – 16
 Technical introduction → A 2 – 8

Heatsinks for PGA

A

B

C

D

E

F

G

H

I

K

L

M

<p>art. no.</p> <p>ICK PGA 20 x 20 K WLF ... 50 x 50</p>		
<p>with fixing clamp for socket 7 and socket 370</p>		
<p>art. no.</p> <p>ICK PGA 20 x 20 x 8 WLF ... 50 x 50</p>		
<p>art. no.</p> <p>ICK PGA 20 x 20 x 12 WLF ... 50 x 50</p>		
<p>art. no.</p> <p>ICK PGA 21 x 21 WLF ... 53 x 53</p>		
<p>art. no.</p> <p>ICK PGA 22 x 22 WLF ... 54 x 54</p>		

B 15

Mounts
Heatsinks for PLCC
Thermal conductive paste
Thermal conductive glue

→ E 44 – 48
→ B 52
→ E 21 – 24
→ E 23 – 24

Pin heatsinks for IC
SMD-heatsinks
Heatsinks for PGA
Technical introduction

→ B 21 – 27
→ B 53 – 54
→ B 11 – 16
→ A 2 – 8

N

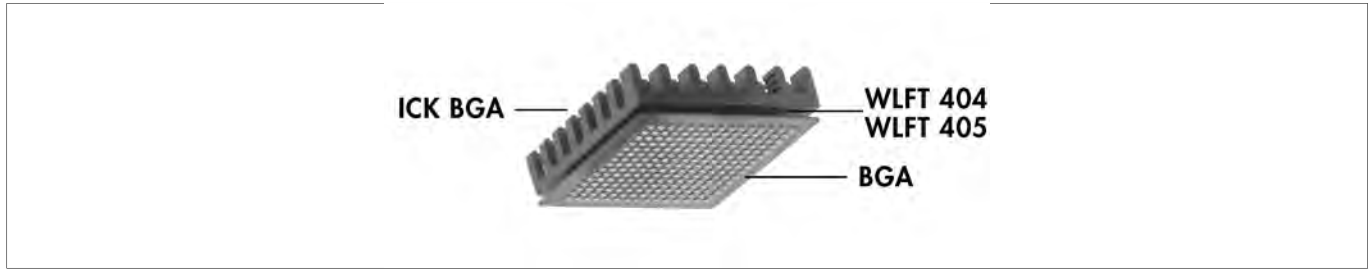

Heatsinks for BGAs



- particularly suited for **B**all **G**rid **A**rrays
- heatsink dimensions match the respective BGA-type
- can be glued directly on the BGA component
- double-sided adhesive thermal conductive foil **WLF ...** → E 7
- **surface:** black anodised

<p>art. no.</p> <p>ICK BGA 10 x 10 WLF ... 10 x 10</p>		
<p>art. no.</p> <p>ICK BGA 10 x 10 x 10 WLF ... 10 x 10</p>		
<p>art. no.</p> <p>ICK BGA 14 x 14 WLF ... 14 x 14</p>		
<p>art. no.</p> <p>ICK BGA 14 x 14 x 10 WLF ... 14 x 14</p>		

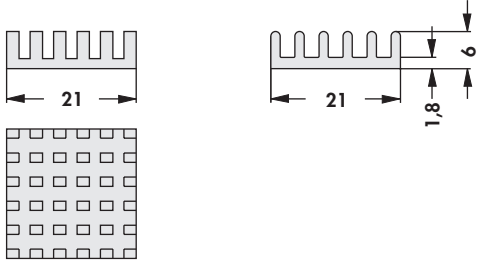
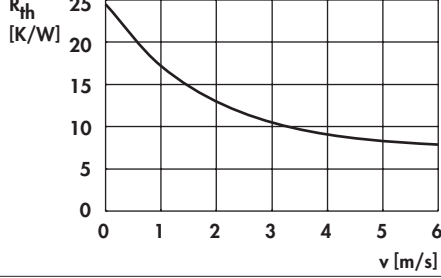
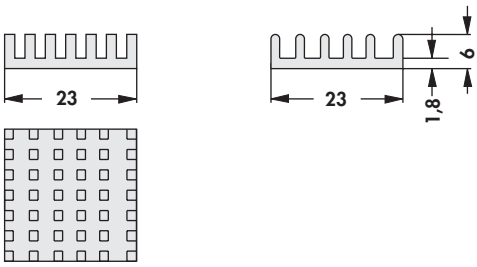
Heatsinks for BGAs

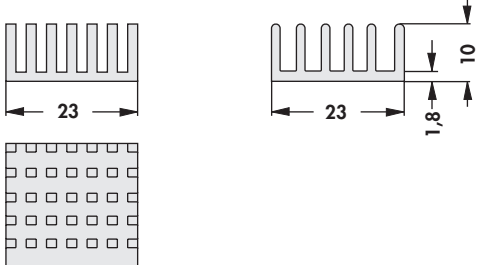
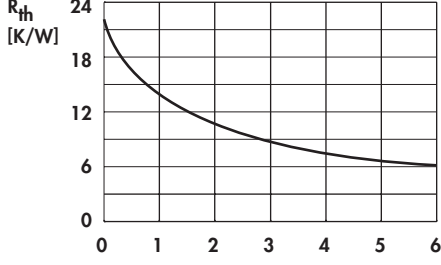
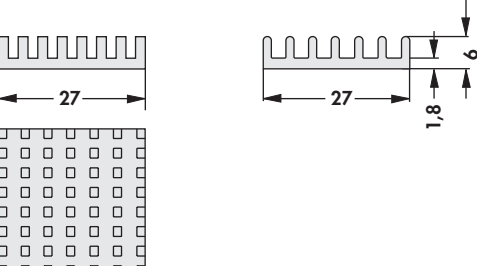
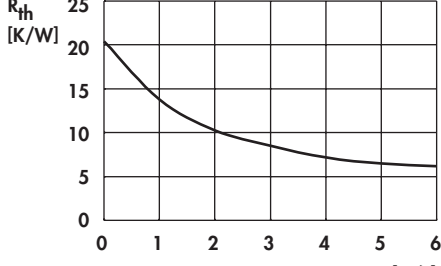
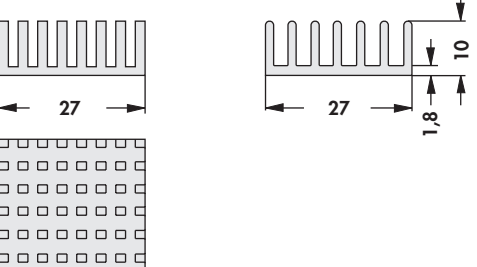
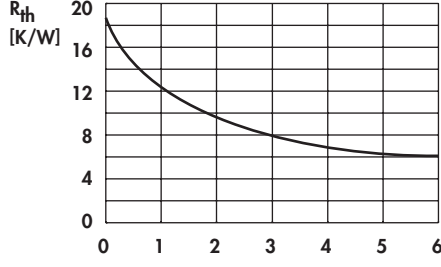
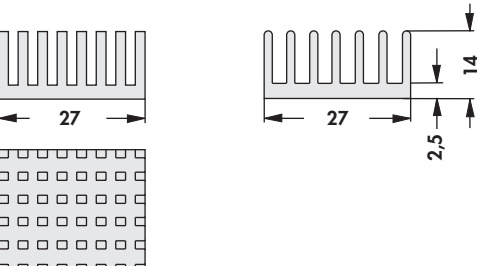
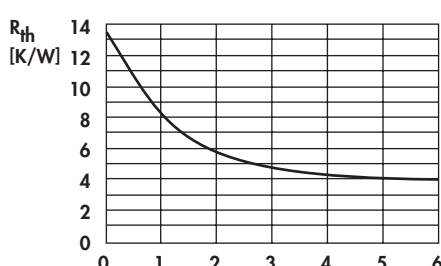
<p>art. no.</p> <p>ICK BGA 21 x 21 WLF ... 21 x 21</p>		
<p>art. no.</p> <p>ICK BGA 23 x 23 WLF ... 23 x 23</p>		
<p>art. no.</p> <p>ICK BGA 23 x 23 x 10 WLF ... 23 x 23</p>		
<p>art. no.</p> <p>ICK BGA 27 x 27 WLF ... 27 x 27</p>		
<p>art. no.</p> <p>ICK BGA 27 x 27 x 10 WLF ... 27 x 27</p>		
<p>art. no.</p> <p>ICK BGA 27 x 27 x 14 WLF ... 27 x 27</p>		

Mounts
SMD-heatsinks
Thermally conductive foil
Thermal conductive paste

→ E 44 – 48
→ B 53 – 55
→ E 5 – 15
→ E 21 – 22

Thermal conductive glue
Hole pattern
Processor overview
Technical introduction

→ E 23 – 24
→ A 21
→ B 2 – 10
→ A 2 – 8

Heatsinks for BGAs

A

B

C

D

E

F

G

H

I

K

L

M

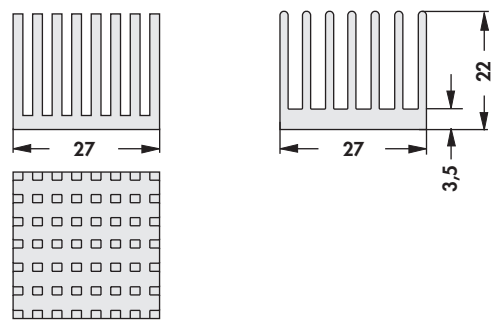
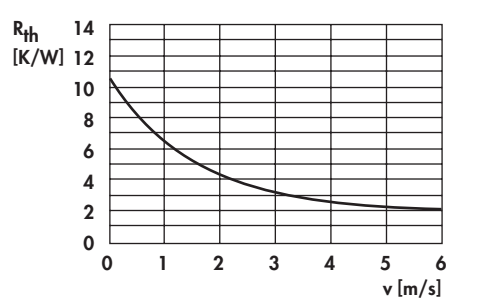
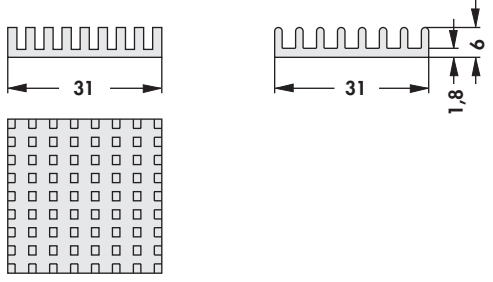
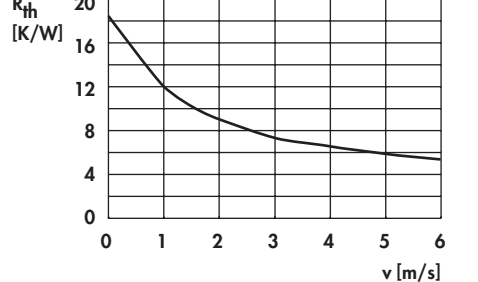
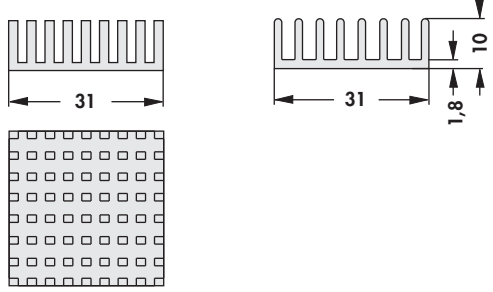
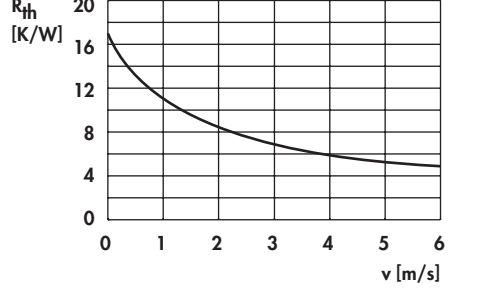
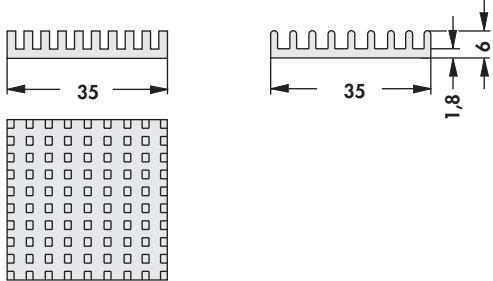
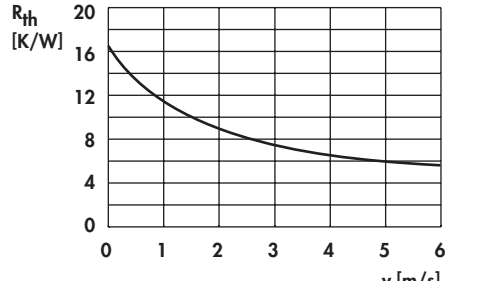
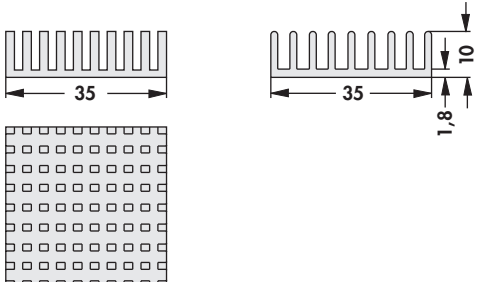
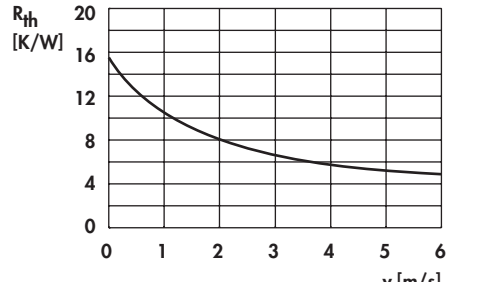
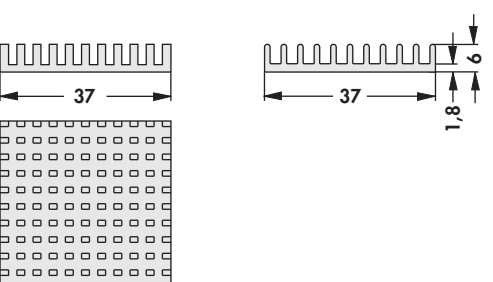
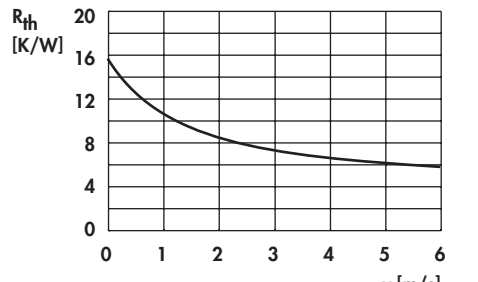
<p>art. no.</p> <p>ICK BGA 27 x 27 x 22 WLF ... 27 x 27</p>		
<p>art. no.</p> <p>ICK BGA 31 x 31 WLF ... 31 x 31</p>		
<p>art. no.</p> <p>ICK BGA 31 x 31 x 10 WLF ... 31 x 31</p>		
<p>art. no.</p> <p>ICK BGA 35 x 35 WLF ... 35 x 35</p>		
<p>art. no.</p> <p>ICK BGA 35 x 35 x 10 WLF ... 35 x 35</p>		
<p>art. no.</p> <p>ICK BGA 37 x 37 x 6 WLF ... 37 x 37</p>		

B 19

Mounts
SMD-heatsinks
Thermally conductive foil
Thermal conductive paste

→ E 44 – 48
→ B 53 – 55
→ E 5 – 15
→ E 21 – 22

Thermal conductive glue
Hole pattern
Processor overview
Technical introduction

→ E 23 – 24
→ A 21
→ B 2 – 10
→ A 2 – 8

N

Heatsinks for BGAs

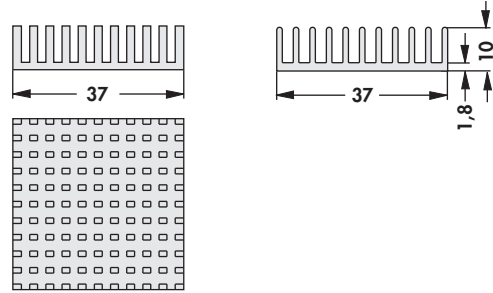
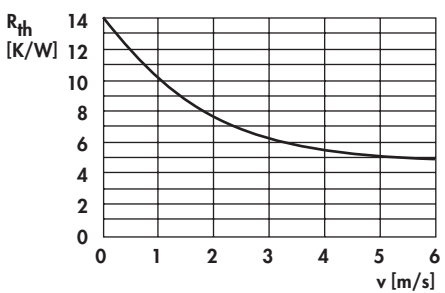
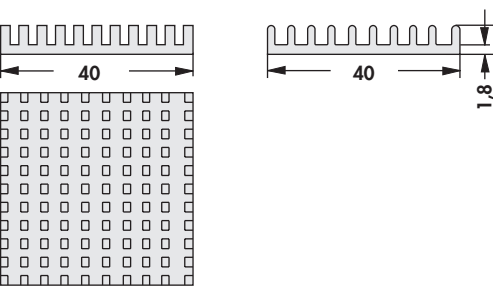
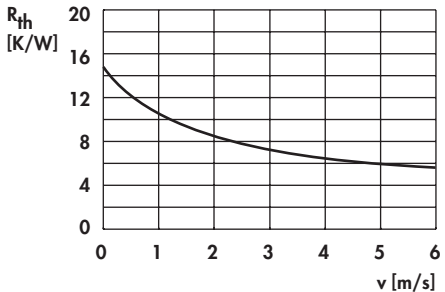
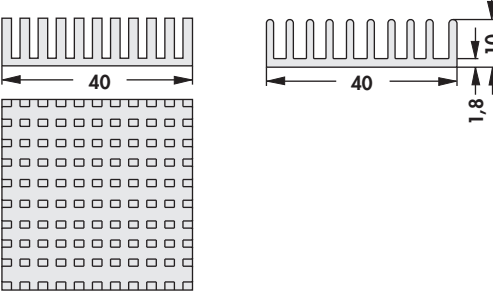
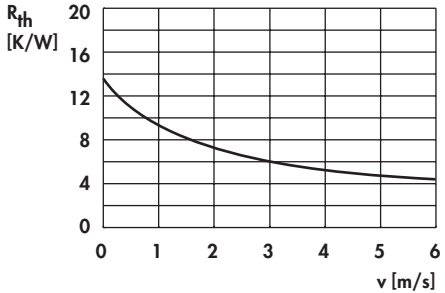
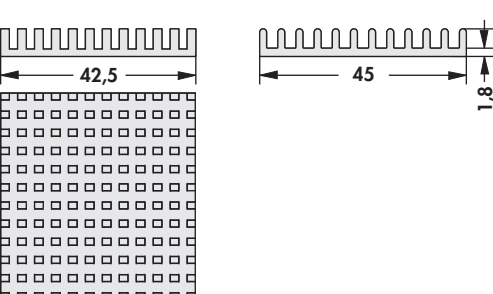
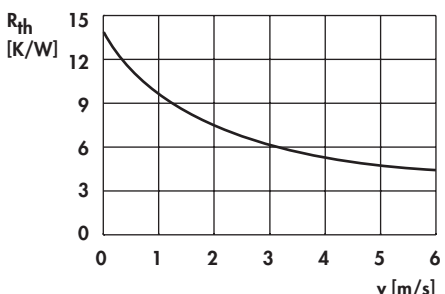
<p>art. no.</p> <p>ICK BGA 37 x 37 x 10 WLF ... 37 x 37</p>		
<p>art. no.</p> <p>ICK BGA 40 x 40 WLF ... 40 x 40</p>		
<p>art. no.</p> <p>ICK BGA 40 x 40 x 10 WLF ... 40 x 40</p>		
<p>art. no.</p> <p>ICK BGA 42,5 x 45 WLF ... 42,5 x 45</p>		

Mounts
SMD-heatsinks
Thermally conductive foil
Thermal conductive paste

→ E 44 – 48
→ B 53 – 55
→ E 5 – 15
→ E 21 – 22

Thermal conductive glue
Hole pattern
Processor overview
Technical introduction

→ E 23 – 24
→ A 21
→ B 2 – 10
→ A 2 – 8

Pin heatsinks

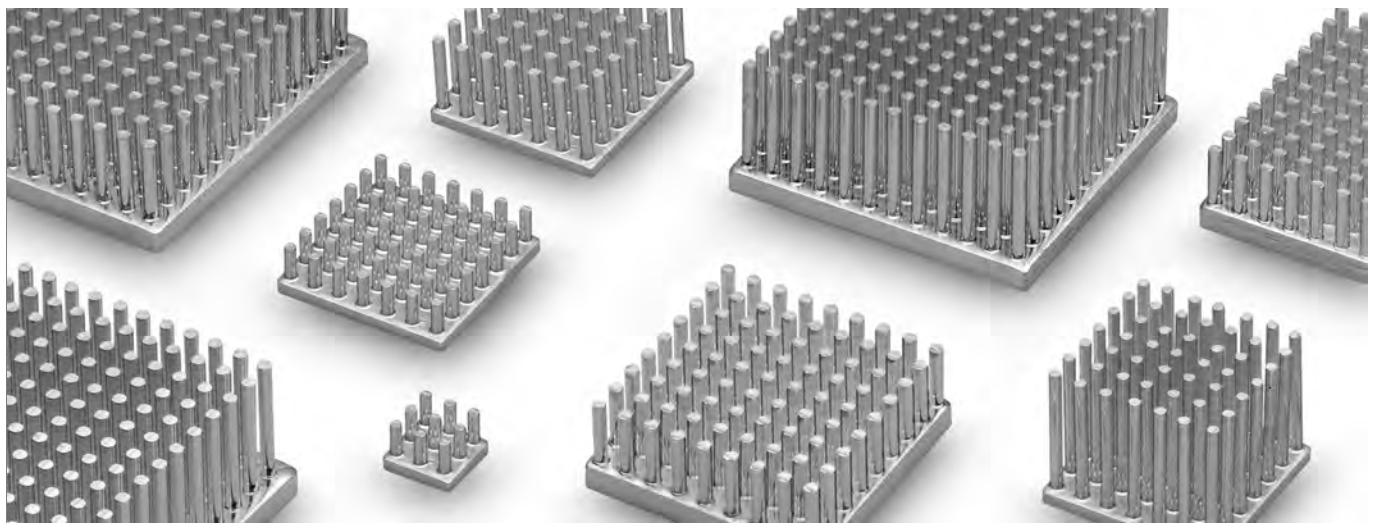

- arrangement and number of pins for optimum air flow
- suitable for forced and free convection
- excellent thermal conductivity by the alloy material (Al99,5; 220 W/mK) and homogeneous arrangement of materials
- constant heat dissipation in the base and the pins in the direction of heat flow
- low weight achieved by optimised geometry
- components fastened using glue, adhesive foil or clamps
- customer-specific modifications and special designs
- other pin-lengths and surfaces on request
- **surface:** Al-natural

<p>art. no.</p> <p>ICK S 10 x 10 x 6,5 WLF ... 10 x 10 weight: 1g</p>		
<p>art. no.</p> <p>ICK S 10 x 10 x 10 WLF ... 10 x 10 weight: 1g</p>		
<p>art. no.</p> <p>ICK S 10 x 10 x 12,5 WLF ... 10 x 10 weight: 1.3g</p>		

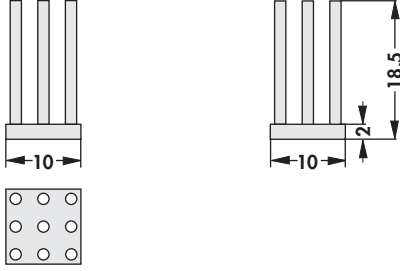
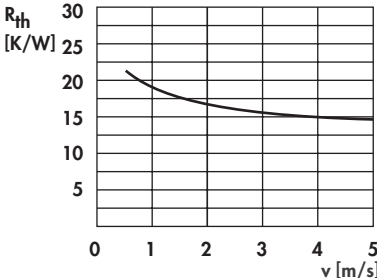
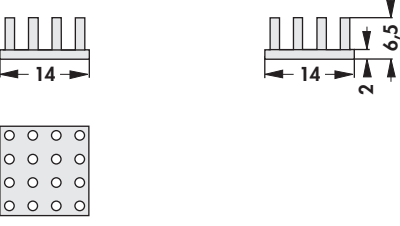
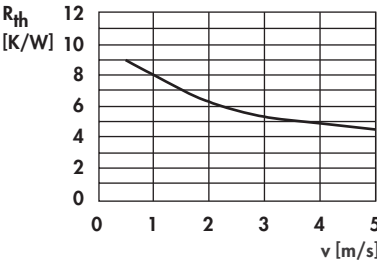
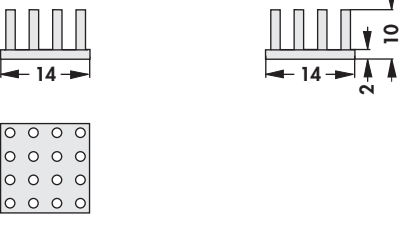
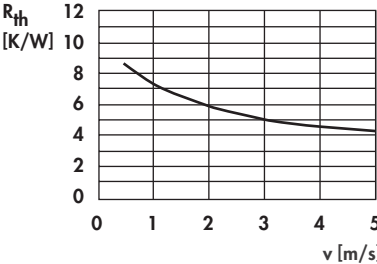
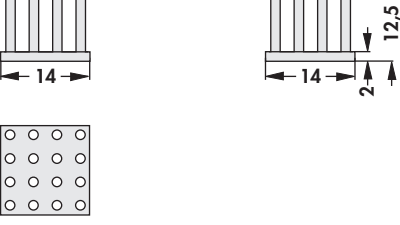
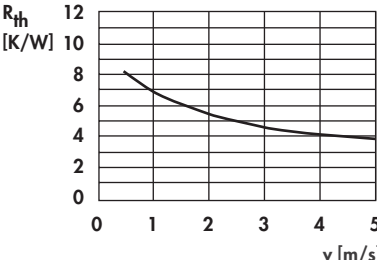
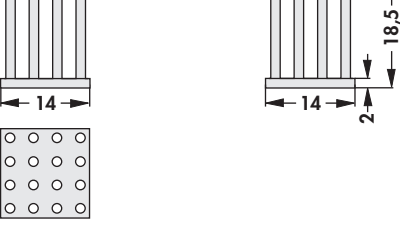
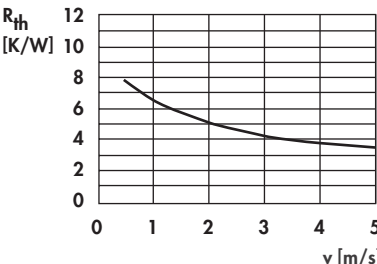
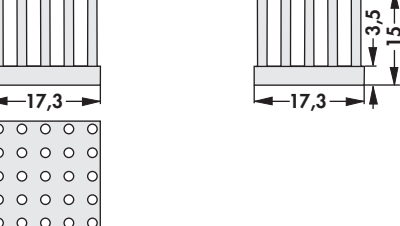
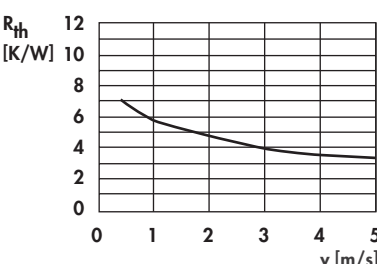

Pin heatsinks

<p>art. no.</p> <p>ICK S 10 x 10 x 18,5 WLF ... 10 x 10 weight: 1.3g</p>		
<p>art. no.</p> <p>ICK S 14 x 14 x 6,5 WLF ... 14 x 14 weight: 1.5g</p>		
<p>art. no.</p> <p>ICK S 14 x 14 x 10 WLF ... 14 x 14 weight: 1.9g</p>		
<p>art. no.</p> <p>ICK S 14 x 14 x 12,5 WLF ... 14 x 14 weight: 2g</p>		
<p>art. no.</p> <p>ICK S 14 x 14 x 18,5 WLF ... 14 x 14 weight: 2.4g</p>		
<p>art. no.</p> <p>ICK S 17 x 17 x 15 WLF ... 17 x 17 weight: 4.7g</p>		

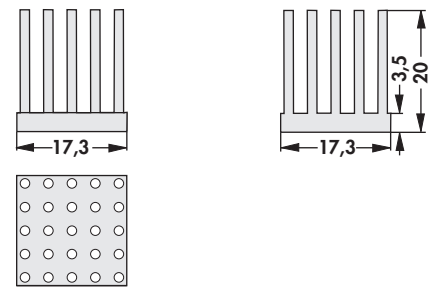
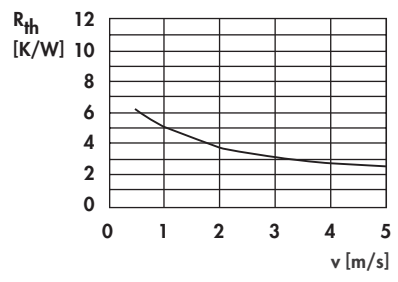
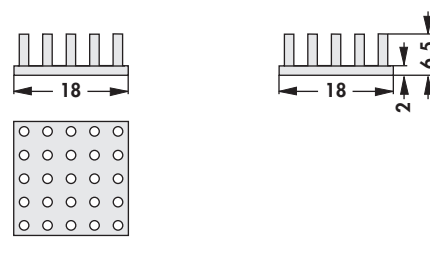
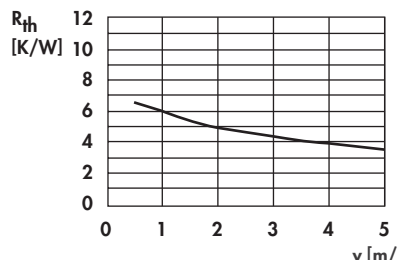
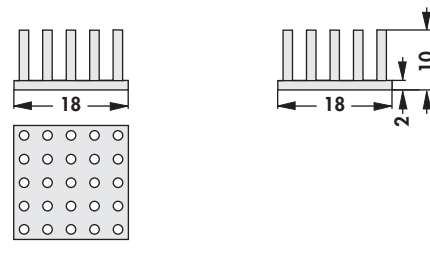
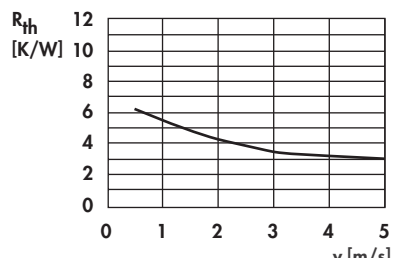
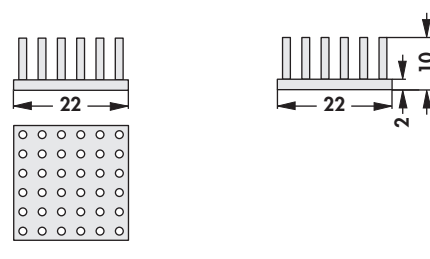
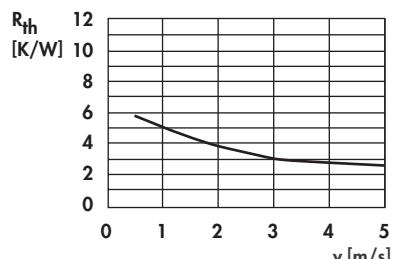
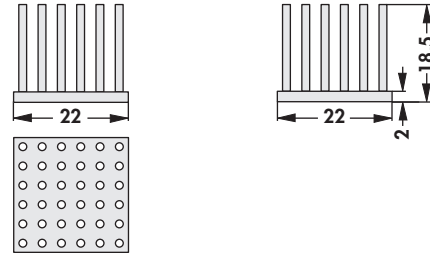
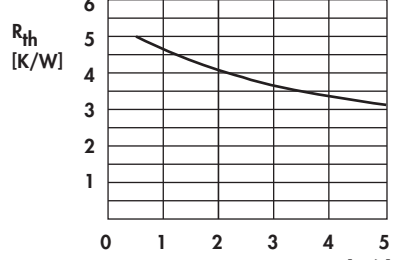
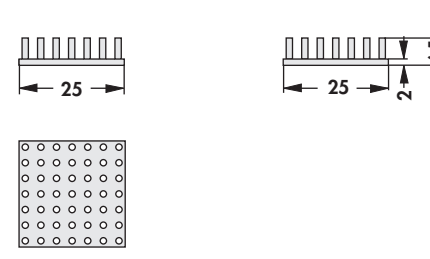
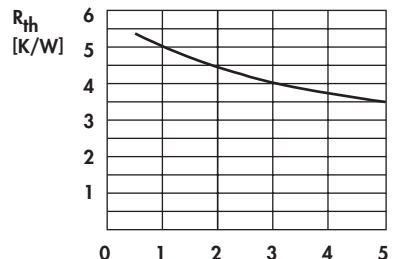
Pin heatsinks

<p>art. no.</p> <p>ICK S 17 x 17 x 20 WLF ... 17 x 17 weight: 5.6g</p>		
<p>art. no.</p> <p>ICK S 18 x 18 x 6,5 WLF ... 18 x 18 weight: 2.5g</p>		
<p>art. no.</p> <p>ICK S 18 x 18 x 10 WLF ... 18 x 18 weight: 3.1g</p>		
<p>art. no.</p> <p>ICK S 22 x 22 x 10 WLF ... 22 x 22 weight: 4g</p>		
<p>art. no.</p> <p>ICK S 22 x 22 x 18,5 WLF ... 22 x 22 weight: 5.4g</p>		
<p>art. no.</p> <p>ICK S 25 x 25 x 6,5 WLF ... 25 x 25 weight: 4g</p>		

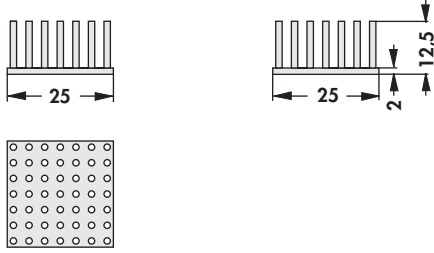
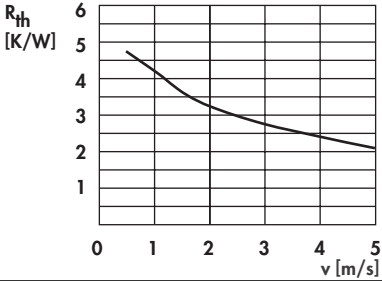
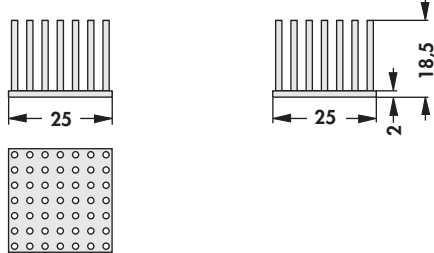
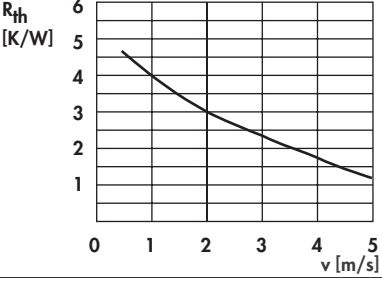
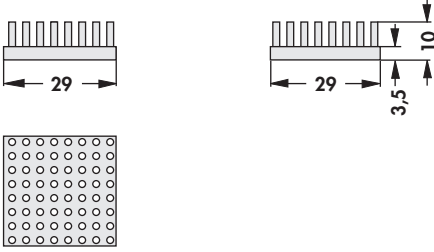
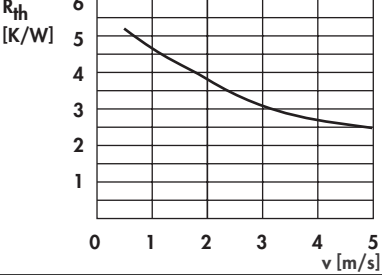
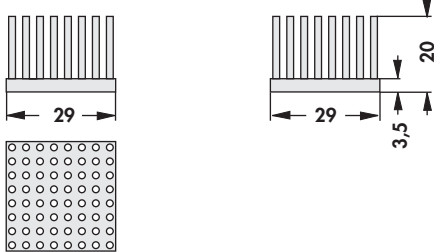
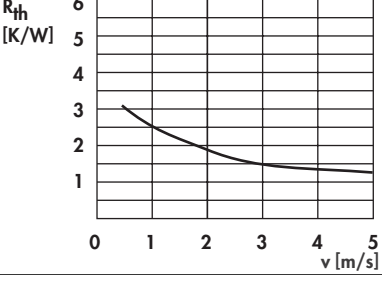
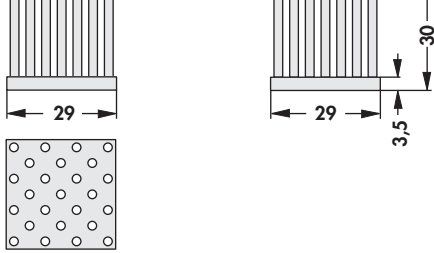
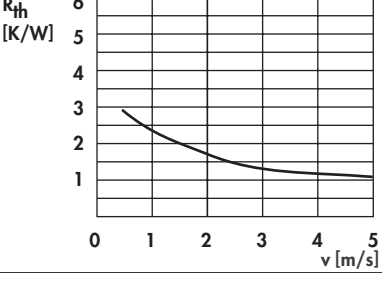
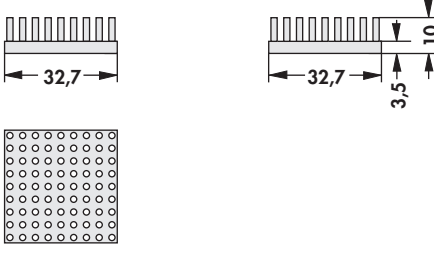
Pin heatsinks

<p>art. no.</p> <p>ICK S 25 x 25 x 12,5 WLF ... 25 x 25 weight: 6g</p>		
<p>art. no.</p> <p>ICK S 25 x 25 x 18,5 WLF ... 25 x 25 weight: 7g</p>		
<p>art. no.</p> <p>ICK S 29 x 29 x 10 WLF ... 29 x 29 weight: 11g</p>		
<p>art. no.</p> <p>ICK S 29 x 29 x 20 WLF ... 29 x 29 weight: 15g</p>		
<p>art. no.</p> <p>ICK S 29 x 29 x 30 WLF ... 29 x 29 weight: 15.4g</p>		
<p>art. no.</p> <p>ICK S 32 x 32 x 10 WLF ... 32 x 32 weight: 14g</p>		

Pin heatsinks

<p>art. no.</p> <p>ICK S 32 x 32 x 20 WLF ... 32 x 32 weight: 19g</p>		
<p>art. no.</p> <p>ICK S 36 x 36 x 10 WLF ... 36 x 36 weight: 17g</p>		
<p>art. no.</p> <p>ICK S 36 x 36 x 15 WLF ... 36 x 36 weight: 20g</p>		
<p>art. no.</p> <p>ICK S 36 x 36 x 20 WLF ... 36 x 36 weight: 24g</p>		
<p>art. no.</p> <p>ICK S 36 x 36 x 30 WLF ... 36 x 36 weight: 24.4g</p>		
<p>art. no.</p> <p>ICK S 40 x 40 x 10 WLF ... 40 x 40 weight: 21g</p>		

Pin heatsinks

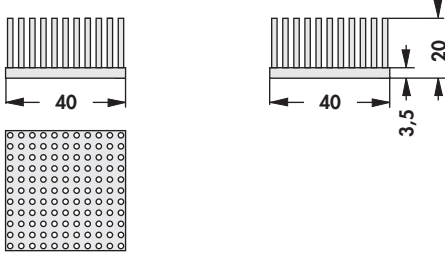
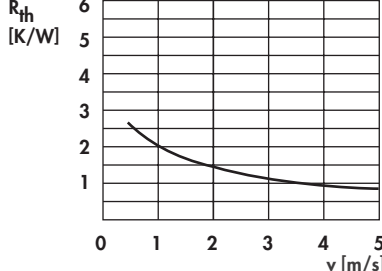
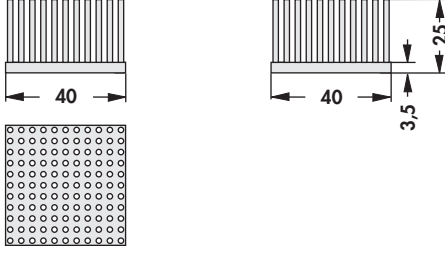
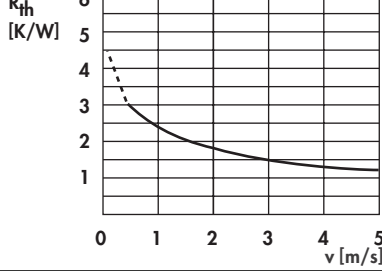
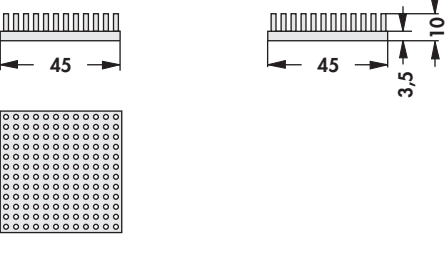
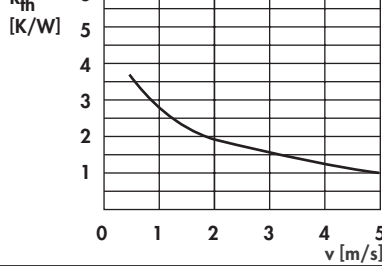
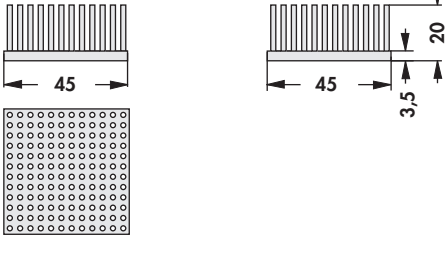
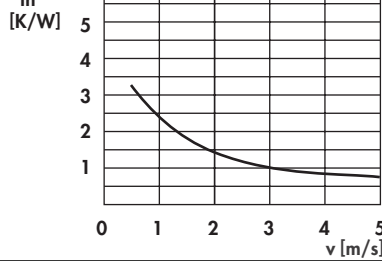
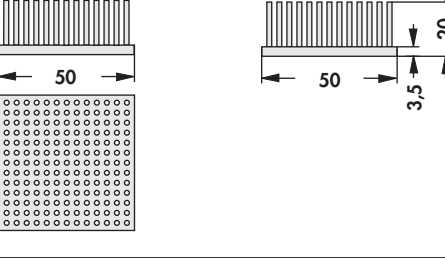
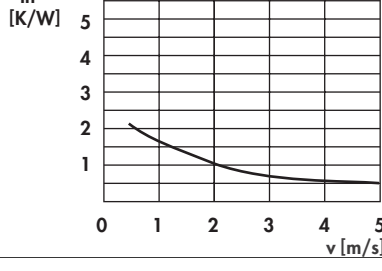
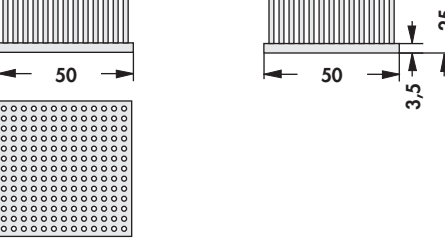
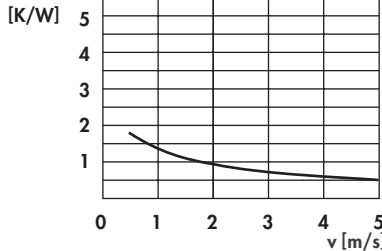
<p>art. no.</p> <p>ICK S 40 x 40 x 20 WLF ... 40 x 40 weight: 29g</p>		
<p>art. no.</p> <p>ICK S 40 x 40 x 25 WLF ... 40 x 40 weight: 37g</p>		
<p>art. no.</p> <p>ICK S 45 x 45 x 10 WLF ... 45 x 45 weight: 26g</p>		
<p>art. no.</p> <p>ICK S 45 x 45 x 20 WLF ... 45 x 45 weight: 36g</p>		
<p>art. no.</p> <p>ICK S 50 x 50 x 20 WLF ... 50 x 50 weight: 43g</p>		
<p>art. no.</p> <p>ICK S 50 x 50 x 25 WLF ... 50 x 50 weight: 49g</p>		

Processor overview
Mounts
SMD-heatsinks
Thermally conductive foil

→ B 2 – 10
→ E 44 – 48
→ B 53 – 55
→ E 5 – 15

Thermal conductive paste
Thermal conductive glue
Heatsinks for LEDs
Technical introduction

→ E 21 – 22
→ E 23 – 24
→ B 35 – 48
→ A 2 – 8

Pin heatsinks

A
B
C
D
E
F
G
H
I
K
L
M
N

<p>art. no.</p> <p>ICK S 50 x 50 x 40 WLF ... 50 x 50 weight: 80.05g</p>		
<p>art. no.</p> <p>ICK S 50 x 50 x 50 WLF ... 50 x 50 weight: 95.51g</p>		
<p>art. no.</p> <p>ICK S 98 x 98 x 30 WLF ... 98 x 98 weight: nullg</p>		
<p>art. no.</p> <p>ICK S 98 x 98 x 45 WLF ... 98 x 98 weight: 301.3g</p>		



Pin heatsinks

Dome

<p>art. no.</p> <p>ICK S D 12 x 12 x 7,5 WLF ... 12 x 12 weight: 1.8g</p>		
<p>art. no.</p> <p>ICK S D 18 x 12 x 7,5 WLF ... 12 x 18 weight: 2.7g</p>		
<p>art. no.</p> <p>ICK S D 24 x 18 x 7,5 WLF ... 18 x 24 weight: 4.4g</p>		
<p>art. no.</p> <p>ICK S D 98 x 98 x 10 WLF ... 98 x 98 weight: 154g</p>		

Pin heatsinks

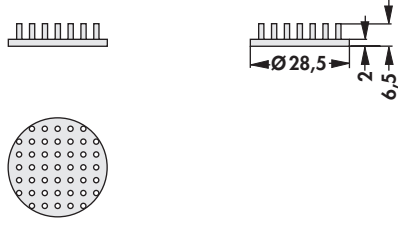
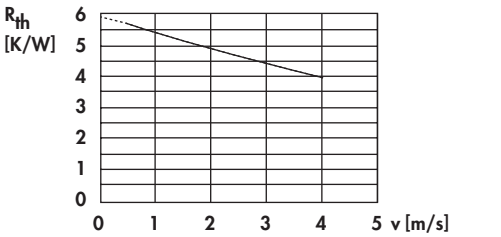
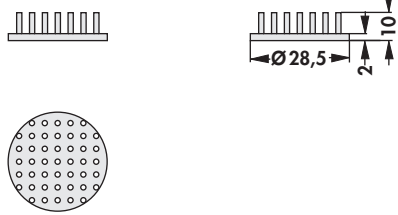
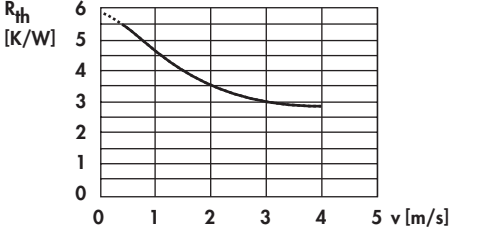
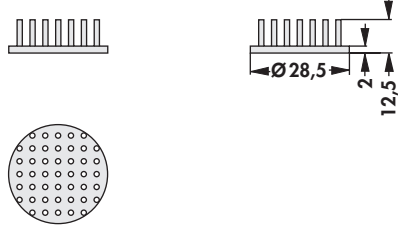
Round

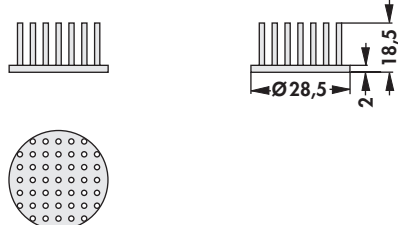
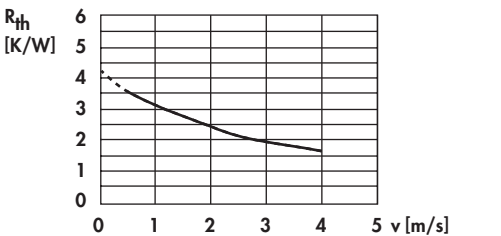
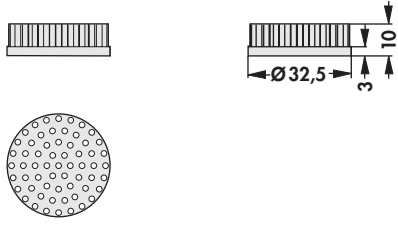
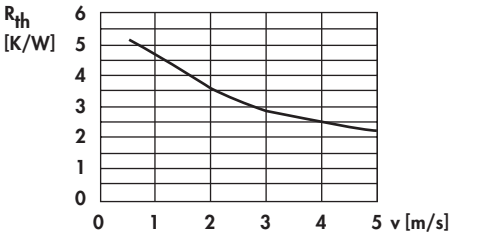
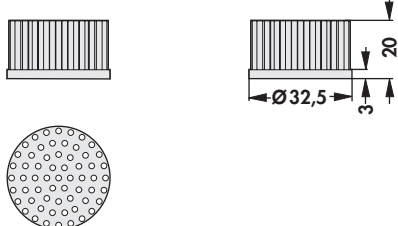
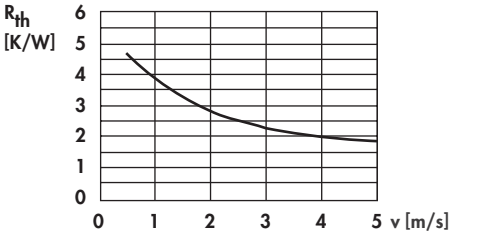
<p>art. no.</p> <p>ICK S R 28,5 x 6,5 WLF ... D 28,5 weight: 4.41g</p>		
<p>art. no.</p> <p>ICK S R 28,5 x 10 WLF ... D 28,5 weight: 5.16g</p>		
<p>art. no.</p> <p>ICK S R 28,5 x 12,5 WLF ... D 28,5 weight: 5.7g</p>		
<p>art. no.</p> <p>ICK S R 28,5 x 18,5 WLF ... D 28,5 weight: 6.98g</p>		
<p>art. no.</p> <p>ICK S R 32,5 x 10 WLF ... D 32 weight: 9.7g</p>		
<p>art. no.</p> <p>ICK S R 32,5 x 20 WLF ... D 32 weight: 13.8g</p>		

Pin heatsinks

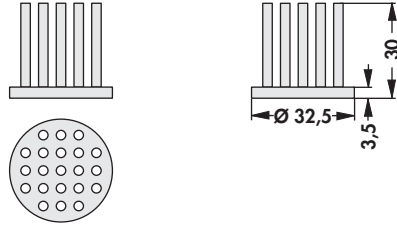
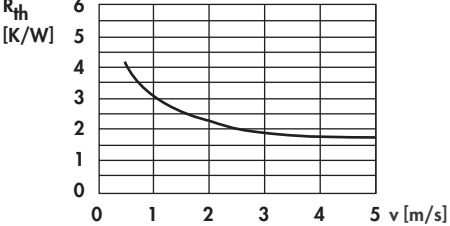
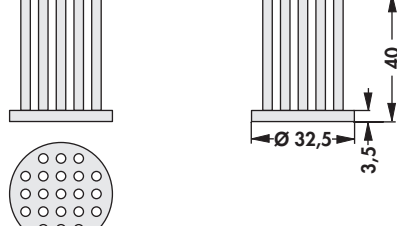
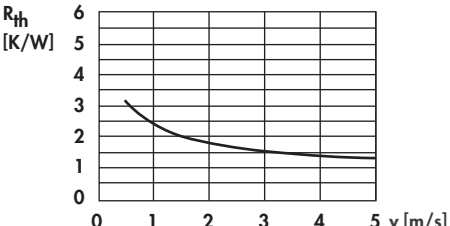
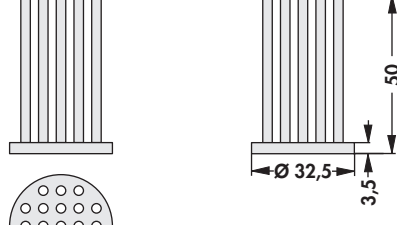
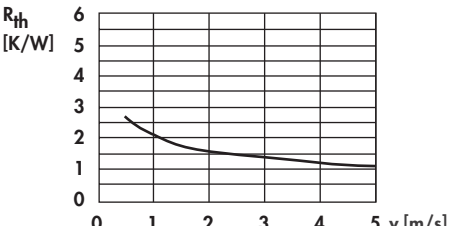
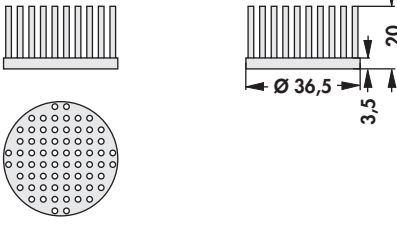
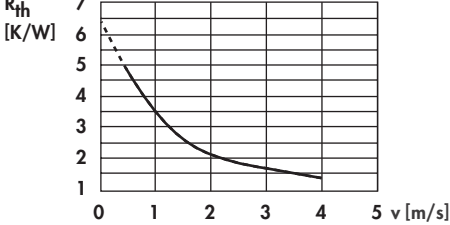
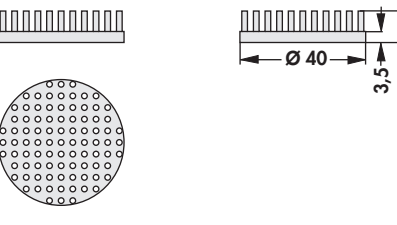
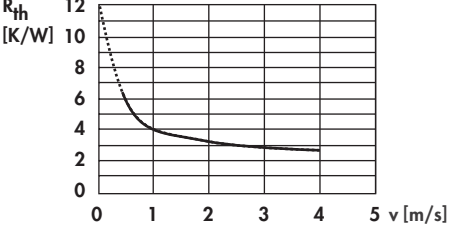
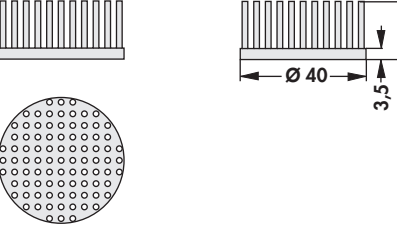
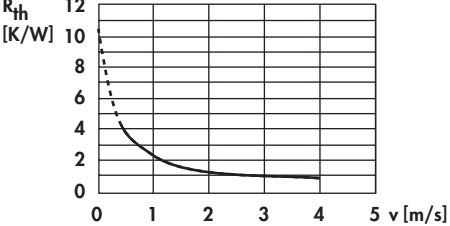
<p>art. no.</p> <p>ICK S R 32,5 x 30 WLF ... D 32 weight: 20.6g</p>		
<p>art. no.</p> <p>ICK S R 32,5 x 40 WLF ... D 32 weight: 24.61g</p>		
<p>art. no.</p> <p>ICK S R 32,5 x 50 WLF ... D 32 weight: 28.62g</p>		
<p>art. no.</p> <p>ICK S R 36,5 x 20 WLF ... D 36,5 weight: 17.59g</p>		
<p>art. no.</p> <p>ICK S R 40 x 10 WLF ... D 40 weight: 15.85g</p>		
<p>art. no.</p> <p>ICK S R 40 x 20 WLF ... D 40 weight: 21.96g</p>		

Thermal conductive glue
Thermal conductive paste
SMD-heatsinks
Processor overview

→ E 23 – 24
→ E 21 – 22
→ B 53 – 55
→ B 2 – 8

Mounting material for semiconduct.
Thermally conductive foil
Heatsinks for LEDs
Technical introduction

→ E 44 – 48
→ E 5 – 15
→ B 35 – 51
→ A 2 – 8

Pin heatsinks

<p>art. no.</p> <p>ICK S R A 40 x 20 WLF ... D 40 weight: 22.18g</p>		
<p>art. no.</p> <p>ICK S R 40 x 30 WLF ... D 40 weight: 29.24g</p>		
<p>art. no.</p> <p>ICK S R 40 x 50 WLF ... D 40 weight: 47.96g</p>		
<p>art. no.</p> <p>ICK S R 45 x 30 WLF ... D 45 weight: 37.78g</p>		
<p>art. no.</p> <p>ICK S R 45 x 45 WLF ... D 45 weight: 50.67g</p>		
<p>art. no.</p> <p>ICK S R 50 x 10 WLF ... D 50 weight: 22g</p>		

B 31

Thermal conductive glue
Thermal conductive paste
SMD-heatsinks
Processor overview

→ E 23 – 24
→ E 21 – 22
→ B 53 – 55
→ B 2 – 8

Mounting material for semiconduct.
Thermally conductive foil
Heatsinks for LEDs
Technical introduction

→ E 44 – 48
→ E 5 – 15
→ B 35 – 51
→ A 2 – 8

Pin heatsinks

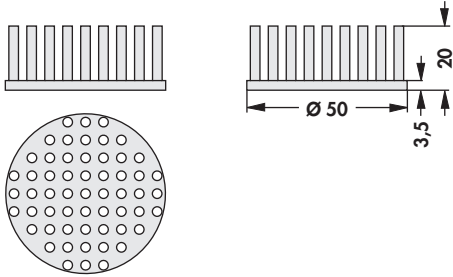
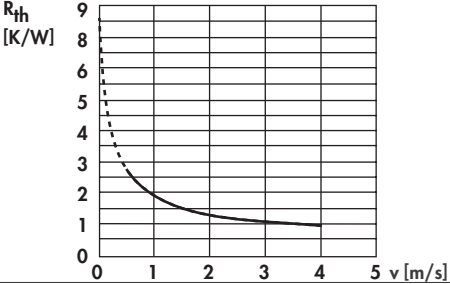
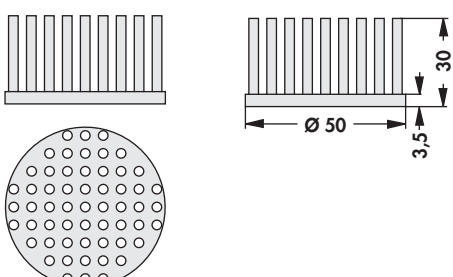
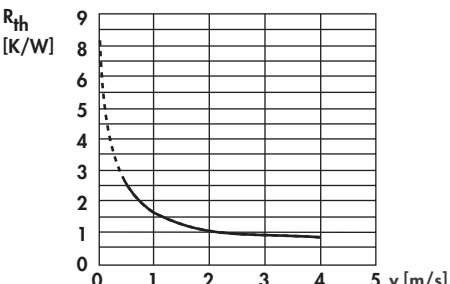
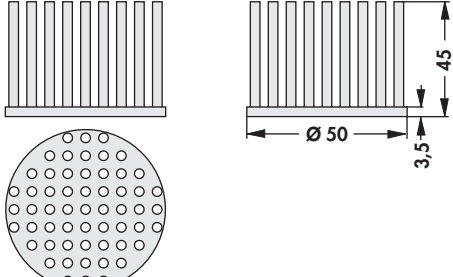
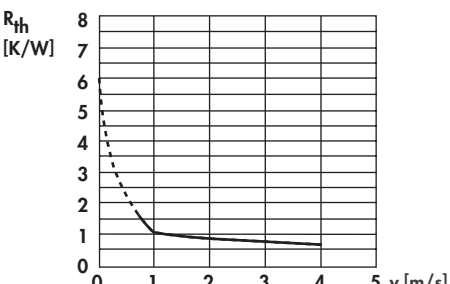
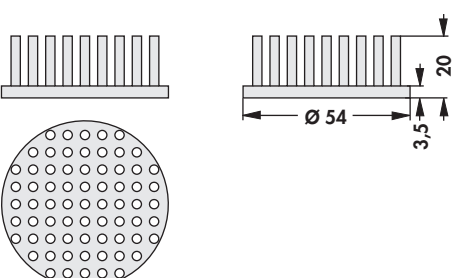
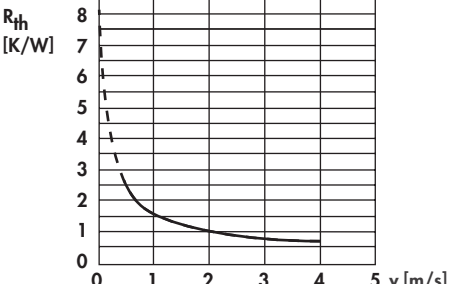
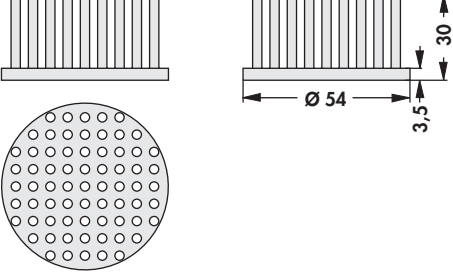
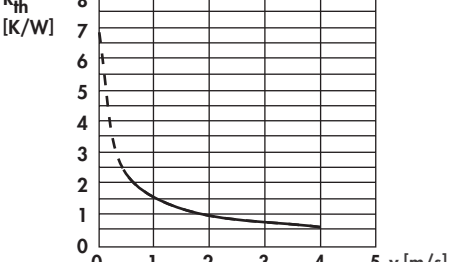
<p>art. no.</p> <p>ICK S R 50 x 20 WLF ... D 50 weight: 34.39g</p>		
<p>art. no.</p> <p>ICK S R 50 x 30 WLF ... D 50 weight: 45.28g</p>		
<p>art. no.</p> <p>ICK S R 50 x 45 WLF ... D 50 weight: 61.59g</p>		
<p>art. no.</p> <p>ICK S R 54 x 20 WLF ... D 54 weight: 40.94g</p>		
<p>art. no.</p> <p>ICK S R 54 x 30 WLF ... D 54 weight: 54.11g</p>		

Pin heatsinks

<p>art. no.</p> <p>ICK S R 54 x 45 WLF ... D 54 weight: 73.86g</p>		
<p>art. no.</p> <p>ICK S R 70 x 30 WLF ... D 70 weight: 92.8g</p>		
<p>art. no.</p> <p>ICK S R 70 x 50 WLF ... D 70 weight: 135.56g</p>		
<p>art. no.</p> <p>ICK S R 85 x 30 WLF ... D 85 weight: nullg</p>		
<p>art. no.</p> <p>ICK S R 85 x 45 WLF ... D 85 weight: nullg</p>		

Pin heatsinks

<p>art. no.</p> <p>ICK S R 98 x 30 WLF ... D 98 weight: nullg</p>		
<p>art. no.</p> <p>ICK S R 98 x 50 WLF ... D 98 weight: 194.23g</p>		



Heatsinks for LEDs



- suitable for free or forced convection
- heat sink dimensions are fitted to the respective LED type
- simple mounting by using thermally conductive adhesive foil, glue or screw mounting
- specific versions on customer's request
- double-sided adhesive thermal conductive foil **WLF ...** → E 7
- special design, surfaces and modification to customer specification on request
- **surface:** black anodised

<p>art. no.</p> <p>ICK LED R 23,5 x 14 WLF ... D 23</p>		<p>$R_{th} = 18,58 \text{ K/W}$</p>
<p>art. no.</p> <p>ICK LED R 23,5 x 14 G WLF ... D 23</p>		
<p>art. no.</p> <p>ICK LED R 27 x 10 WLF ... D 27</p>		<p>$R_{th} = 17,69 \text{ K/W}$</p>
<p>art. no.</p> <p>ICK LED R 27 x 10 G WLF ... D 27</p>		
<p>art. no.</p> <p>ICK LED R 28 x 15 WLF ... D 28</p>		<p>$R_{th} = 15,24 \text{ K/W}$</p>

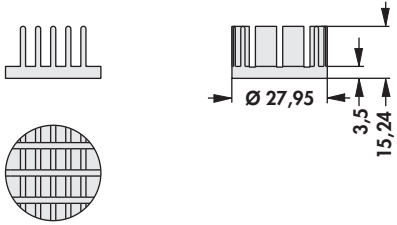
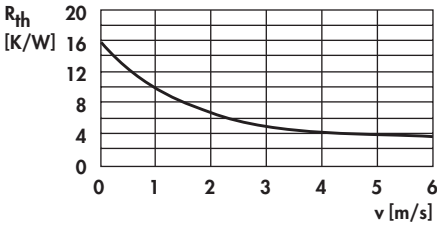
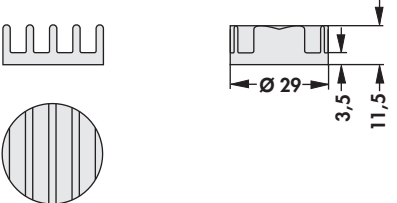
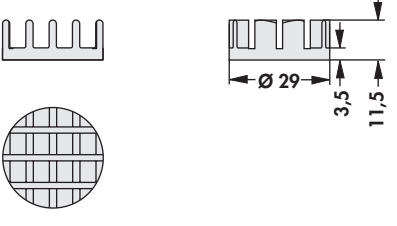
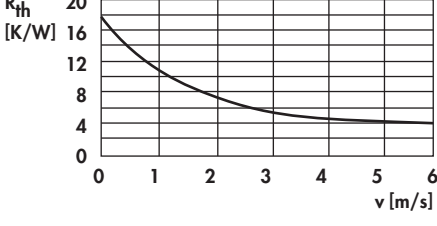
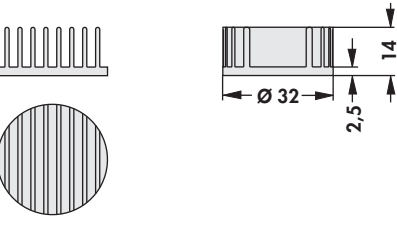
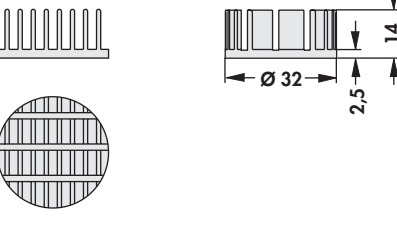
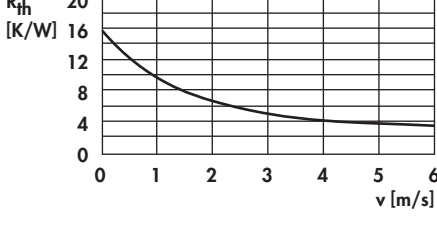
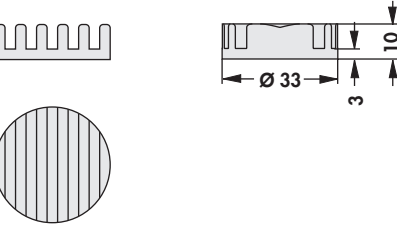
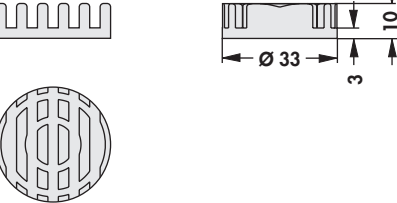
Heatsinks for LEDs

<p>art. no.</p> <p>ICK LED R 28 x 15 G WLF ... D 28</p>		
<p>art. no.</p> <p>ICK LED R 29 x 11,5 WLF ... D 29</p>		<p>$R_{th} = 17,26 \text{ K/W}$</p>
<p>art. no.</p> <p>ICK LED R 29 x 11,5 G WLF ... D 29</p>		
<p>art. no.</p> <p>ICK LED R 32 x 14 WLF ... D 32</p>		<p>$R_{th} = 15,23 \text{ K/W}$</p>
<p>art. no.</p> <p>ICK LED R 32 x 14 G WLF ... D 32</p>		
<p>art. no.</p> <p>ICK LED R 33 x 10 WLF ... D 33</p>		<p>$R_{th} = 17,6 \text{ K/W}$</p>
<p>art. no.</p> <p>ICK LED R 33 x 10 G WLF ... D 33</p>		

Pin heatsinks \varnothing
Mounts
Thermally conductive foil
Thermal conductive paste

→ B 29 – 33
→ E 44 – 48
→ E 5 – 15
→ E 21 – 22

Thermal conductive glue
Hole pattern
Heatsink profile-overview
Technical introduction

→ E 23 – 24
→ A 21
→ A 13 – 17
→ A 2 – 8

B 36

Heatsinks for LEDs

A
B
C
D
E
F
G
H
I
K
L
M
N

<p>art. no.</p> <p>ICK LED R 33 x 16,5 WLF ... D 33</p>		<p>$R_{th} = 13,87 \text{ K/W}$</p>
<p>art. no.</p> <p>ICK LED R 33 x 16,5 G WLF ... D 33</p>		
<p>art. no.</p> <p>ICK LED R 35 x 10 WLF ... D 35</p>		<p>$R_{th} = 16,9 \text{ K/W}$</p>
<p>art. no.</p> <p>ICK LED R 35 x 10 G WLF ... D 35</p>		
<p>art. no.</p> <p>ICK LED R 36 x 12 WLF ... D 36</p>		<p>$R_{th} = 12,88 \text{ K/W}$</p>
<p>art. no.</p> <p>ICK LED R 36 x 12 G WLF ... D 36</p>		
<p>art. no.</p> <p>ICK LED R 40 x 10 WLF ... D 40</p>		<p>$R_{th} = 12,28 \text{ K/W}$</p>

B 37

Pin heatsinks Ø
Mounts
Thermally conductive foil
Thermal conductive paste

→ B 29 – 33
→ E 44 – 48
→ E 5 – 15
→ E 21 – 22

Thermal conductive glue
Hole pattern
Heatsink profile-overview
Technical introduction

→ E 23 – 24
→ A 21
→ A 13 – 17
→ A 2 – 8

Heatsinks for LEDs

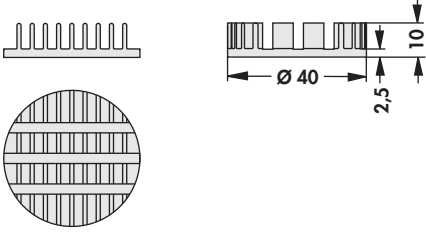
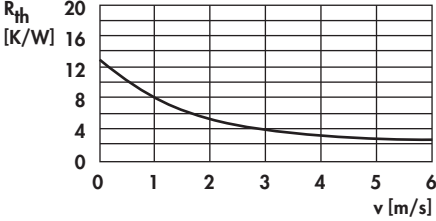
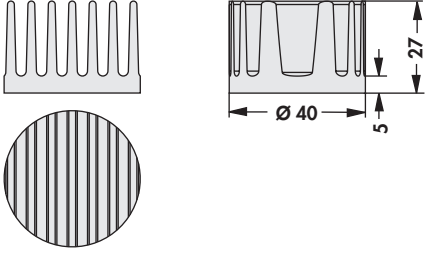
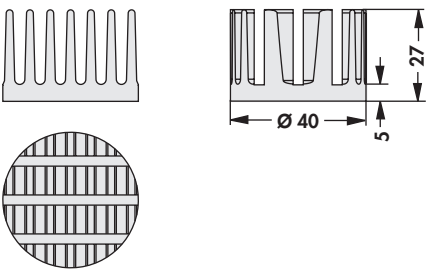
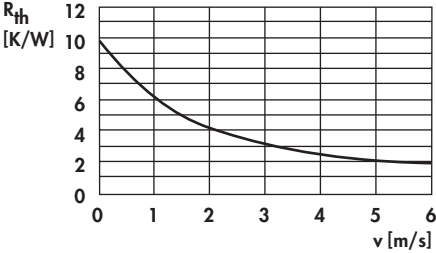
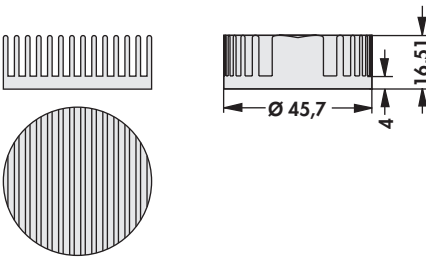
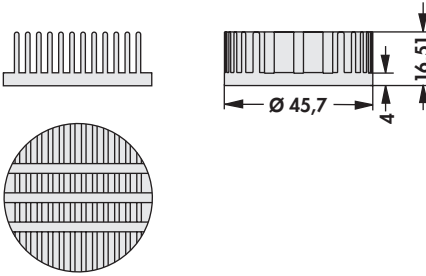
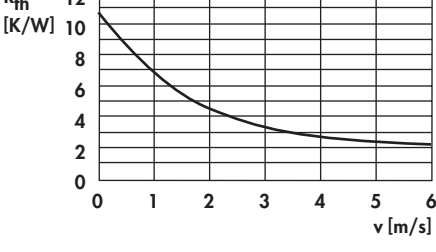
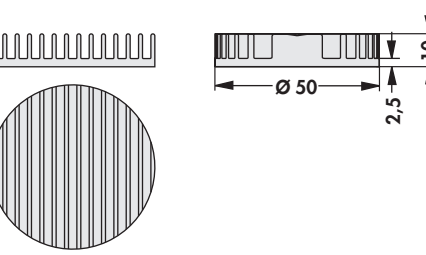
<p>art. no.</p> <p>ICK LED R 40 x 10 G WLF ... D 40</p>		
<p>art. no.</p> <p>ICK LED R 40 x 27 WLF ... D 40</p>		<p>$R_{th} = 9,41 \text{ K/W}$</p>
<p>art. no.</p> <p>ICK LED R 40 x 27 G WLF ... D 40</p>		
<p>art. no.</p> <p>ICK LED R 45,7 x 16,5 WLF ... D 45</p>		<p>$R_{th} = 10,46 \text{ K/W}$</p>
<p>art. no.</p> <p>ICK LED R 45,7 x 16,5 G WLF ... D 45</p>		
<p>art. no.</p> <p>ICK LED R 50 x 10 WLF ... D 50</p>		<p>$R_{th} = 10,57 \text{ K/W}$</p>

Heatsinks for LEDs

<p>art. no.</p> <p>ICK LED R 50 x 10 G WLF ... D 50</p>		
<p>art. no.</p> <p>ICK LED R 50,8 x 16,5 WLF ... D 50</p>		<p>R_{th} = 10,17 K/W</p>
<p>art. no.</p> <p>ICK LED R 50,8 x 16,5 G WLF ... D 50</p>		
<p>art. no.</p> <p>ICK LED R 54 x 20 WLF ... D 54</p>		<p>R_{th} = 9,48 K/W</p>
<p>art. no.</p> <p>ICK LED R 54 x 20 G WLF ... D 54</p>		
<p>art. no.</p> <p>ICK LED R 66 x 40 WLF ... D 66</p>		<p>R_{th} = 3,2 K/W</p>

Heatsinks for LEDs

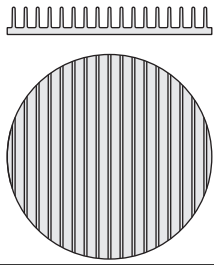
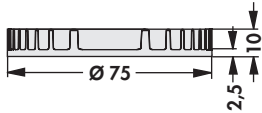
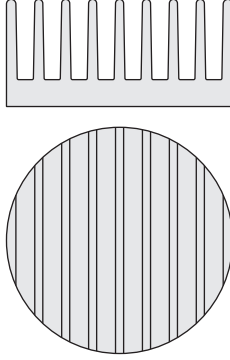
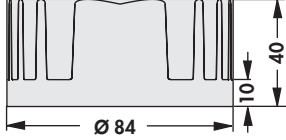
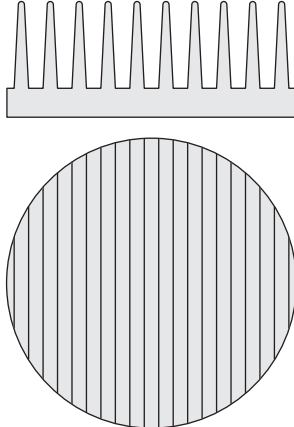
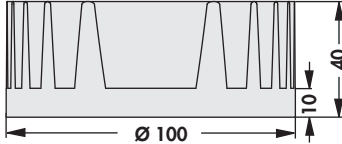
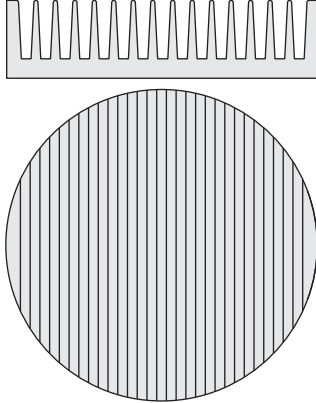
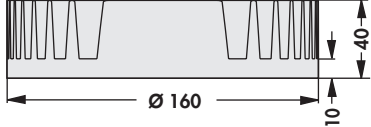
<p>art. no.</p> <p>ICK LED R 75 x 10 WLF ... D 75</p>		 <p>$R_{th} = 5,2 \text{ K/W}$</p>
<p>art. no.</p> <p>ICK LED R 84 x 40 WLF ... D 84</p>		 <p>$R_{th} = 2,5 \text{ K/W}$</p>
<p>art. no.</p> <p>ICK LED R 100 x 40 WLF ... D 100</p>		 <p>$R_{th} = 2 \text{ K/W}$</p>
<p>art. no.</p> <p>ICK LED R 160 x 40 WLF ... D 160</p>		 <p>$R_{th} = 1,4 \text{ K/W}$</p>

A

Heatsinks for LEDs

B

art. no.

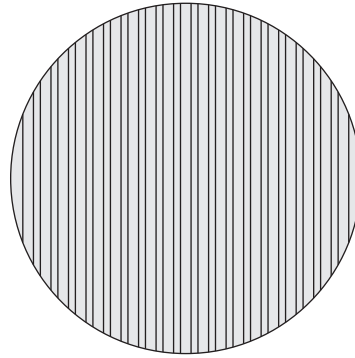
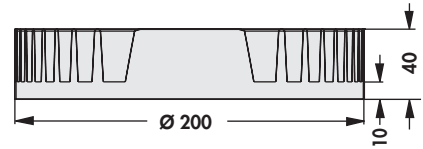
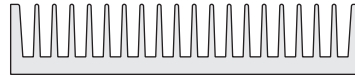

$$R_{th} = 1 \text{ K/W}$$

ICK LED R 200 x 40
 WLF ... D 200

D

E

F

G

H

I

K

L

M

N

B 41

Pin heatsinks Ø
 Mounts
 Thermally conductive foil
 Thermal conductive paste





→ B 29 – 33
 → E 44 – 48
 → E 5 – 15
 → E 21 – 22

Thermal conductive glue
 Hole pattern
 Heatsink profile-overview
 Technical introduction

→ E 23 – 24
 → A 21
 → A 13 – 17
 → A 2 – 8

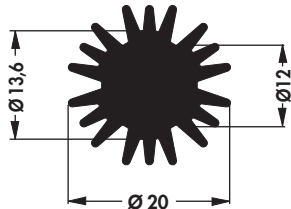
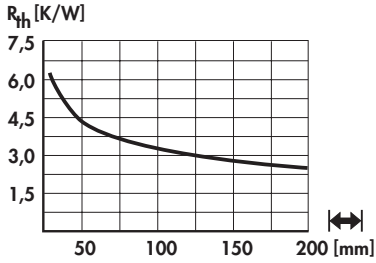
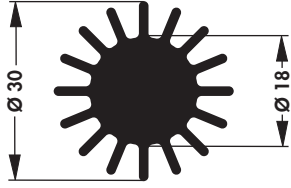
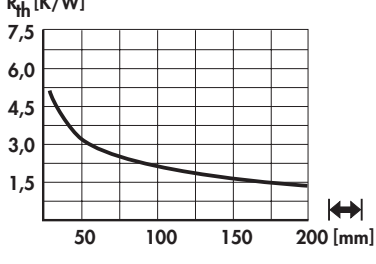
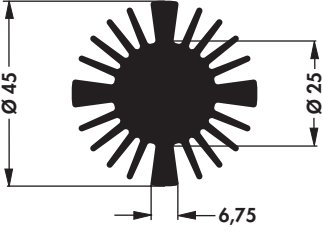
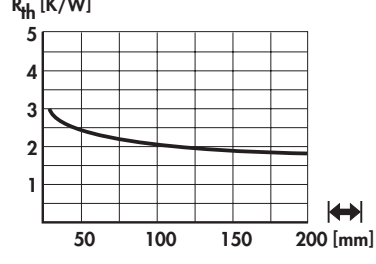
Heatsinks for LEDs

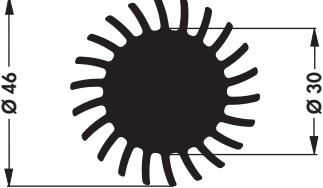
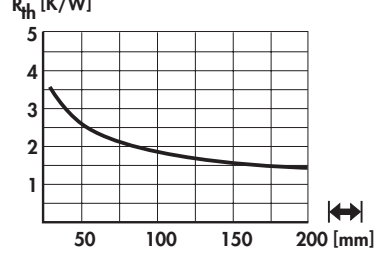
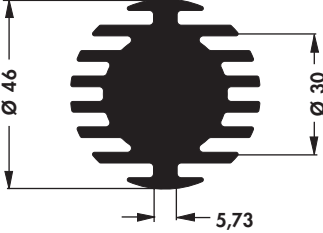
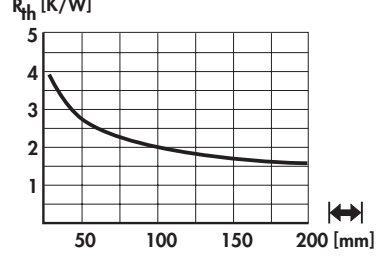
- special design, surfaces and modification to customer specification on request
- up from a profile length of 25 mm: optional adapter plate **LA LED 68 ...** → B 50 suitable for LED modules: Bridgelux Vero, Citizen CitiLED, Cree XLamp, Edison Edilex, GE Infusion, Luga Shop und Industrial, Lustrous Lustron, Megaman Teco, Osram PrevaLED und Soleriq, Philips Fortimo und Luxeon, Prolight Opto, Sharp Mega Zenigata, Toshiba E-Core, Tridonic Stark, Vexica Lumaera, Vossloh Schwabe

art. no. SK 585 ...		
art. no. SK 620 ...		
art. no. SK 618 ...		
please indicate: ...  10 15 20 25 37.5 50 1000 mm		
surface: black anodised		
art. no. SK 619 ...		
art. no. SK 598 ...		
please indicate: ...  10 15 20 25 37.5 50 1000 mm		
surface: black anodised		
... adapter (optional) AD = adapter plate		

Pin heatsinks Ø
Hole pattern
Special heatsink design
Thermal conductive paste

→ B 29 – 33 Mounts
→ A 21 Thermally conductive foil
→ A 137 – 138 Thermal conductive glue
→ E 21 – 22 Technical introduction

→ E 44 – 48
→ E 5 – 15
→ E 23 – 24
→ A 2 – 8

Heatsinks for LEDs

<p>art. no.</p> <p>SK 602 ...</p>		
<p>art. no.</p> <p>SK 577 ...</p>		
<p>art. no.</p> <p>SK 46 ...</p>		
<p>art. no.</p> <p>SK 578 ...</p>		
<p>art. no.</p> <p>SK 569 ...</p>		
<p>please indicate: ... $\left[\text{mm} \right]$ 10 15 20 25 37.5 50 1000 mm</p>		<p>... adapter (optional) AD = adapter plate</p>
<p>surface: black anodised</p>		

Heatsinks for LEDs

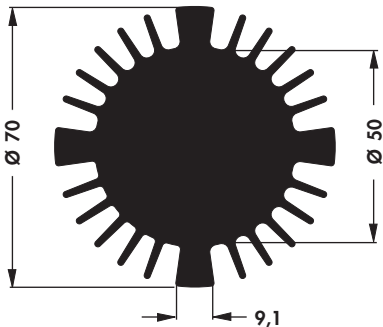
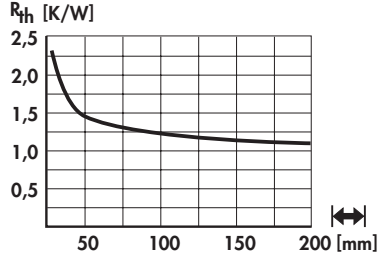
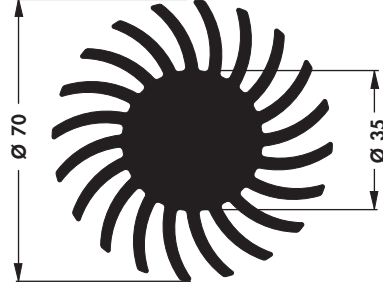
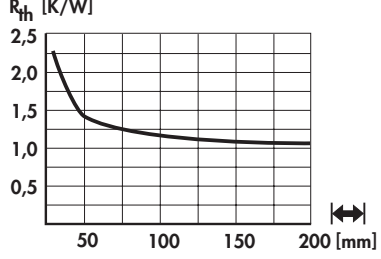
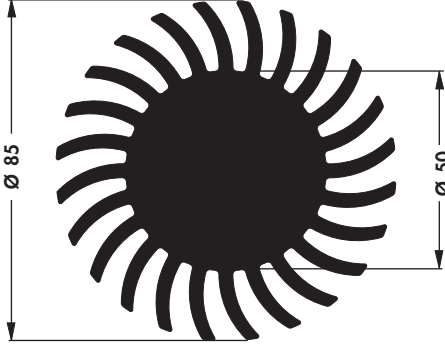
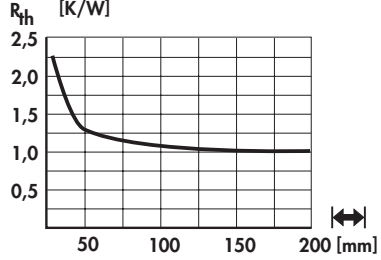
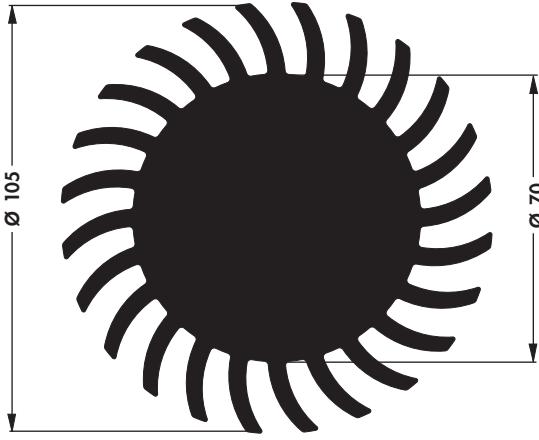
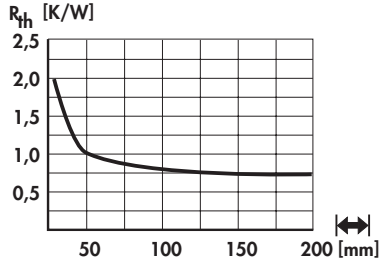
<p>art. no.</p> <p>SK 570 ...</p>		
<p>art. no.</p> <p>SK 571 ...</p>		
<p>art. no.</p> <p>SK 572 ...</p>		
<p>please indicate: ... $\left[\begin{array}{c} \text{---} \\ \text{---} \\ \text{---} \end{array} \right]$ 10 15 20 25 37.5 50 1000 mm ... adapter (optional) AD = adapter plate</p>		
<p>surface: black anodised</p>		
<p>art. no.</p> <p>SK 584 ...</p>		
<p>please indicate: ... $\left[\begin{array}{c} \text{---} \\ \text{---} \\ \text{---} \end{array} \right]$ 10 15 20 25 37.5 50 1000 mm</p>		
<p>surface: black anodised</p>		

Heatsinks for LEDs

A
B
C
D
E
F
G
H
I
K
L
M
N

<p>art. no.</p> <p>SK 615 ...</p>		
<p>art. no.</p> <p>SK 599 ...</p>		
<p>art. no.</p> <p>SK 592 ...</p>		
<p>please indicate: ... $\left[\text{mm} \right]$ 10 15 20 25 37.5 50 75 100 150 1000 mm</p>		
<p>surface: black anodised</p>		

B 45

Pin heatsinks Ø
 Hole pattern
 Special heatsink design
 Thermal conductive paste

→ B 29 – 33 Mounts
 → A 21 Thermally conductive foil
 → A 137 – 138 Thermal conductive glue
 → E 21 – 22 Technical introduction

→ E 44 – 48
 → E 5 – 15
 → E 23 – 24
 → A 2 – 8

Heatsinks for LEDs

art. no.		
SK 590 ...		
please indicate:	... \varnothing 10 15 20 25 37.5 50 75 100 150 1000 mm	
surface:	black anodised	

Pin heatsinks \varnothing
 Hole pattern
 Special heatsink design
 Thermal conductive paste

→ B 29 – 33 Mounts
 → A 21 Thermally conductive foil
 → A 137 – 138 Thermal conductive glue
 → E 21 – 22 Technical introduction

→ E 44 – 48
 → E 5 – 15
 → E 23 – 24
 → A 2 – 8

B 46

LED fin cooler KTE R customised

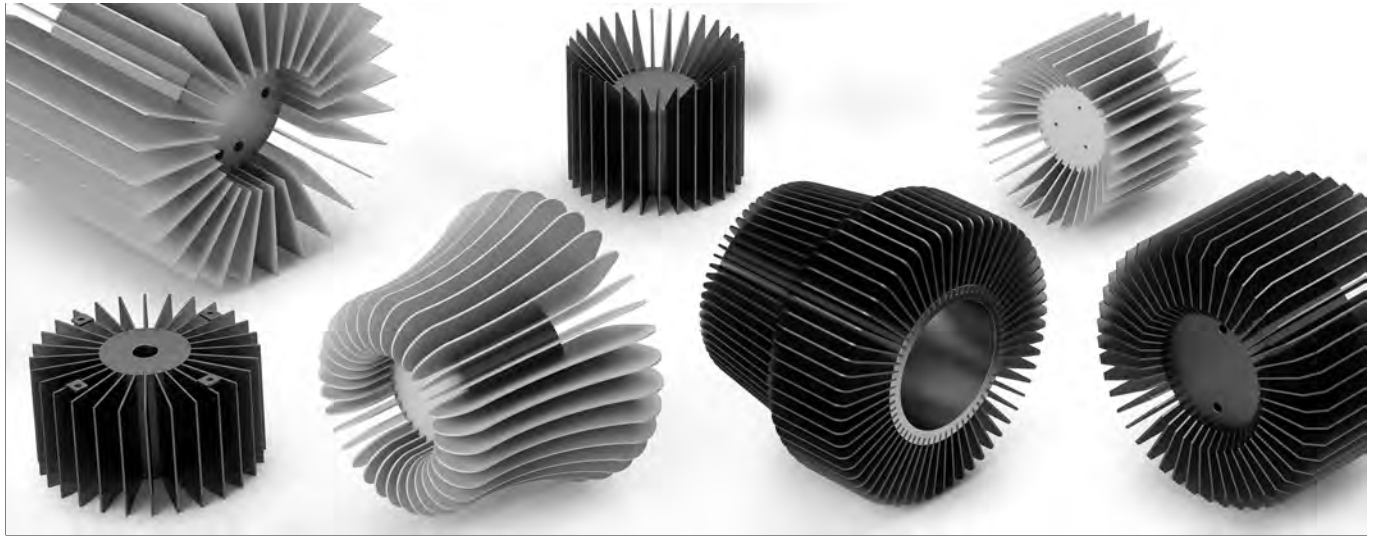

- individual LED heatsinks acc. to customer's requests
- adaptable to all common LED modules and sizes
- integration possibility of reflectors or fans by using special sheet metal design
- entry core for heat dissipation made of copper upon request
- other dimensions, sheet metal geometries, surfaces and mechanical machinings upon request

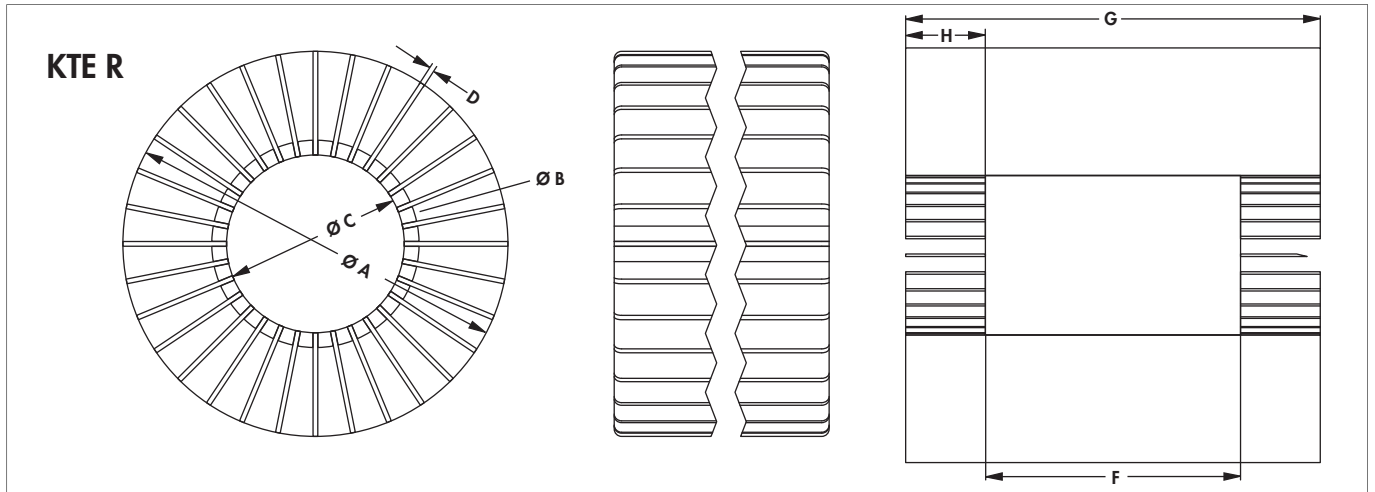

possible dimensions:

dim. [mm]							
A	B	C	D	E	F	G	H
B + 20 to 200	35	30	0.8	32	max. 400	max. 800	max. 200
	40	35		36			
	55	50	50				
	80	75	72				
	90	85	84				
	100	95	92				

E max. number of grooves at D = 0.8 mm

please indicate with your order:

dim. [mm]							
A	B	C	D	E	F	G	H

please indicate: ... surface
 SA = black anodised
 ME = clear anodised

material: aluminium

B 47

Pin heatsinks Ø
 Hole pattern
 Special heatsink design
 Thermal conductive paste

→ B 29 - 33 Mounts
 → A 21 Thermally conductive foil
 → A 137 - 138 Processor overview
 → E 21 - 22 Technical introduction

→ E 44 - 48
 → E 5 - 15
 → B 2 - 10
 → A 2 - 8

Heatsinks for LEDs

- heatsink specially made for flexible and fixed LED Line Modules
- insertion possibility of metal sheets and sheets of Plexiglas
- customer specified designs, lengths and treatments upon request

<p>art. no.</p> <p>SK LED 1</p>		
<p>art. no.</p> <p>SK LED 2</p>		
<p>art. no.</p> <p>SK LED 3</p>		
<p>please indicate: ... $\overline{\quad}$ 50 75 100 150 1000 mm</p>		<p>... surface SA = black anodised ME = clear anodised</p>





Pin heatsinks Ø
 Hole pattern
 Special heatsink design
 Thermal conductive paste

→ B 29 - 33 Mounts
 → A 21 Thermally conductive foil
 → A 137 - 138 Processor overview
 → E 21 - 22 Technical introduction

→ E 44 - 48
 → E 5 - 15
 → B 2 - 10
 → A 2 - 8

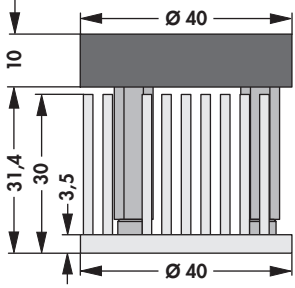
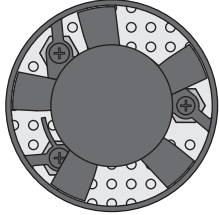
B 48

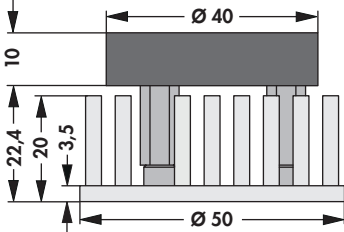
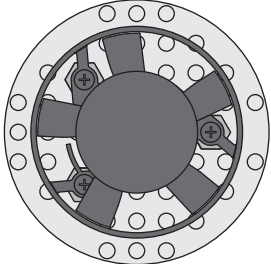
Active heat dissipation of LEDs

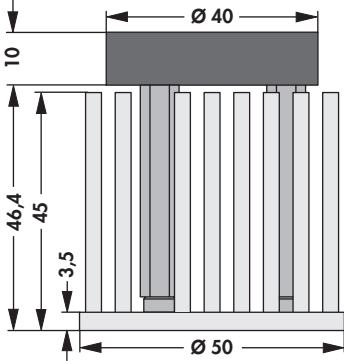
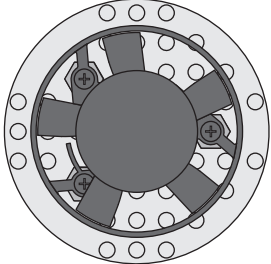
		
<p>art. no. LA LED 40 x 30</p>	<p>R_{th} [K/W] 1.4</p>	
		
<p>art. no. LA LED 50 x 20</p>	<p>R_{th} [K/W] 1.25</p>	
		
<p>art. no. LA LED 50 x 45</p>	<p>R_{th} [K/W] 0.9</p>	

Technical data of the fans

	LF 40B12
circuit voltage	12 V
bearing type	two-way plain bearing
cur. consumpt.	50 mA
max. initial current	160 mA
max. volume flow	157 l/min - 9.4 m ³ /h
max. static pressure	3.4 mmH ₂ O - 33 Pa
noise level	26 dB(A), 1 m lateral
temperature range	-20°C... +60°C
failure rate (L ₁₀)	60,000 h
MTBF	1,900,000 h (20°C)
Type rotor speed	6,600 min ⁻¹
weight	10 g

Active heat dissipation of LEDs



- active heat dissipation of LED modules
- Zhaga compliant mounting possibility
- integrated low noise fan
- optional adapter plate suitable for LED modules:
Bridgelux Vero, Citizen CitiLED, Cree XLamp, Edison Edilex, GE Infusion, Luga Shop und Industrial, Lustrous Lustron, Megaman Teco, Osram PrevaLED und Soleriq, Philips Fortimo und Luxeon, Prolight Opto, Sharp Mega Zenigata, Toshiba E-Core, Tridonic Stark, Vexica Lumaera, Vossloh Schwabe

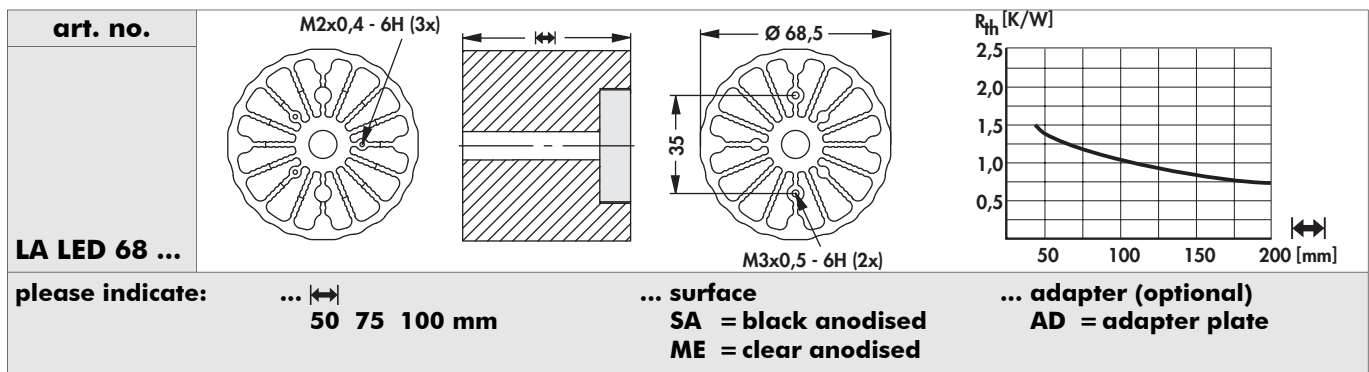

Technical data of the fans

	LF 40B12
circuit voltage	12 V
bearing type	two-way plain bearing
cur. consumpt.	50 mA
max. iinitial current	160 mA
max. volume flow	157 l/min - 9.4 m ³ /h
max. static pressure	3.4 mmH ₂ O - 33 Pa
noise level	26 dB(A), 1 m lateral
temperature range	-20°C... +60°C
failure rate (L₁₀)	60,000 h
MTBF	1,900,000 h (20°C)
Type rotor speed	6,600 min ⁻¹
weight	10 g

Pin heatsinks Ø

Hole pattern

Special heatsink design

Thermal conductive paste

→ B 29 - 33

→ A 21

→ A 137 - 138

→ E 21 - 22

Mounts

Thermally conductive foil

Processor overview

Technical introduction

→ E 44 - 48

→ E 5 - 15

→ B 2 - 10

→ A 2 - 8

B 50

A

Sample box LED Heatsinks

B

- Sample box for verification of the thermal management for LEDs
- Contains a choice of different extruded heatsinks, LED extruded heatsinks in round design, LED pin heatsinks and extruded profiles for LED-Line modules
- for thermal contacting or mounting of LED a high-performance thermal conductive graphite foil is also enclosed (**WLFG**, sample strips 25x150mm), a high-performance thermal conductive (silicone-free) ceramic-filled thermal conductive paste (**WLPK**, syringe), a double-sided sticky thermal conductive foil (**WLFT 404**, sample strips 25x150mm) and a thermal conductive epoxy based two-component adhesive (**WLK DK**, syringe)

C

D

E

F

G

H

I

K

L

M

N



art. no.
SK LED BOX 1

B 51

Pin heatsinks Ø
Hole pattern
Special heatsink design
Thermal conductive paste

→ B 29 – 33
→ A 21
→ A 137 – 138
→ E 21 – 22



Mounts
Thermally conductive foil
Processor overview
Technical introduction

→ E 44 – 48
→ E 5 – 15
→ B 2 – 10
→ A 2 – 8

Heatsinks for DIL-IC and PLCC

Heatsinks for DIL-IC

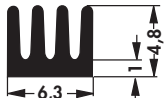
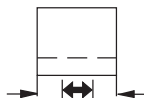

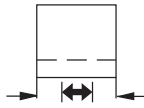
– other length on request

							
art. no.	for cases	↔ [mm]	R_{th} [K/W]	art. no.	for cases	↔ [mm]	R_{th} [K/W]
ICK 6 8 L	6/8 contacts	8.5	83	ICK 20 L	20 contacts	25.0	34
ICK 14 16 L	14/16 contacts	19.0	46				
							
art. no.	for cases	↔ [mm]	R_{th} [K/W]	art. no.	for cases	↔ [mm]	R_{th} [K/W]
ICK 14 16 B	14/16 contacts	6.3	54.0	ICK 36 B	36 contacts	47.0	16.5
ICK 24 B	24 contacts	33.0	19.4	ICK 40 B	40 contacts	51.0	15.8
ICK 28 B	28 contacts	37.0	18.5	ICK 1000 B	—	1000.0	—
surface:		black anodised					

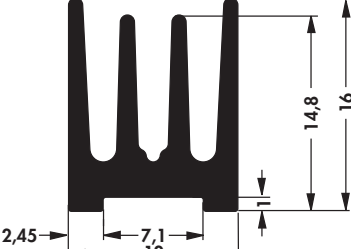
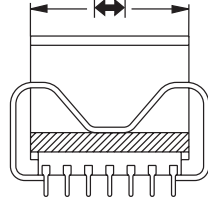
– with clip
– other length on request

							
art. no.	for cases	↔ [mm]	R_{th} [K/W]	art. no.	for cases	↔ [mm]	R_{th} [K/W]
ICK 14 H	14 contacts	18.0	20	ICK 18 H	18 contacts	23.0	16
ICK 16 H	16 contacts	20.5	18	ICK 1000 H	—	1000.0	—
surface:		black anodised					

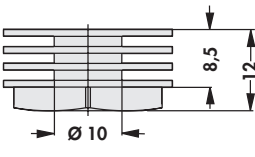
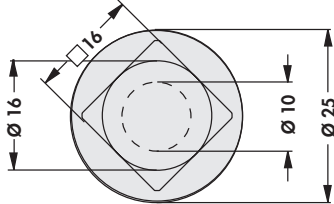
Heatsinks for PLCC

			
art. no.			R_{th} [K/W]
ICK R			19
			
art. no.	↔ [mm]	R_{th} [K/W]	
ICK PLCC 28	11.8	25	
surface:		black anodised	

Extruded heatsinks
Pin heatsinks for IC
Insulating clamping parts
Thermal conductive glue

→ A 22 – 83
→ B 21 – 28
→ E 45
→ E 23 – 24

Thermally conductive foil
Thermal conductive paste
Hole pattern
Technical introduction

→ E 5 – 15
→ E 21 – 22
→ A 21
→ A 2 – 8

Heatsinks for SMD

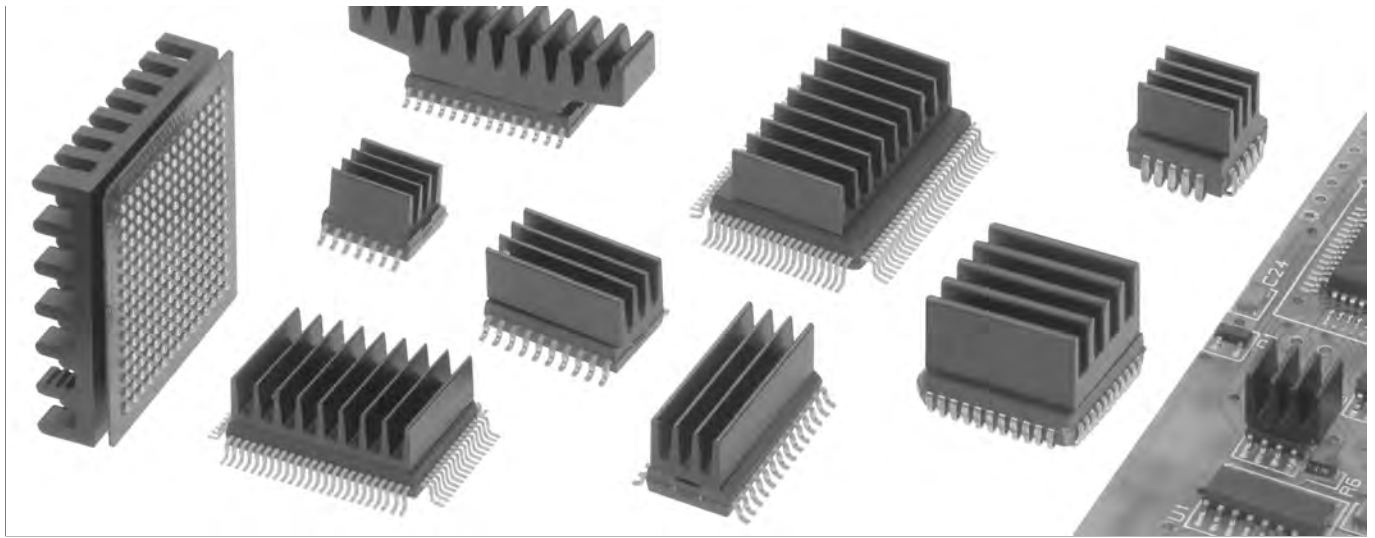

- particularly suitable for SMD components
- low profile
- reduced weight
- effective heat dissipation
- can be glued directly onto the component
- solderable versions
- customer specific versions on request
- special packaging like tape and reel, bar magazin, tray etc. on request

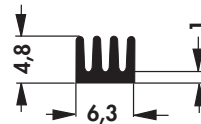

art. no.	↔ [mm]	R _{th} [K/W]	art. no.	↔ [mm]	R _{th} [K/W]
ICK SMD A 5 ...	5	123	ICK SMD A 13 ...	13	63
ICK SMD A 8 ...	8	87	ICK SMD A 17 ...	17	51
ICK SMD A 10 ...	10	75	ICK SMD A 22 ...	22	34

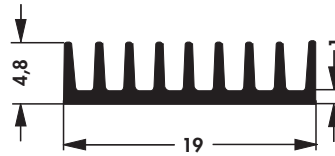

art. no.	↔ [mm]	R _{th} [K/W]	art. no.	↔ [mm]	R _{th} [K/W]
ICK SMD B 5 ...	5	56	ICK SMD B 13 SA	13	29
ICK SMD B 7 SA	7	47	ICK SMD B 19 ...	19	22
ICK SMD B 10 SA	10	35			

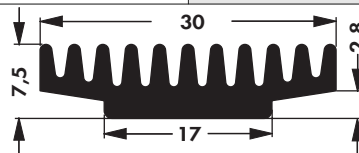

art. no.	↔ [mm]	R _{th} [K/W]	art. no.	↔ [mm]	R _{th} [K/W]
ICK SMD C 7 SA	7	33	ICK SMD C 17 ...	17	17
ICK SMD C 10 SA	10	26			

please indicate: ... surface
 SA = black anodised
 MI = solderable surface

Heatsinks for SMD

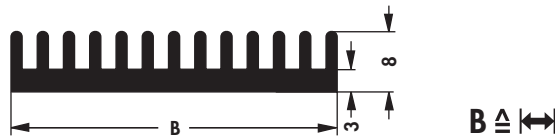

art. no.	↔ [mm]	R _{th} [K/W]	art. no.	↔ [mm]	R _{th} [K/W]
ICK SMD E 15 SA	15.3	27	ICK SMD E 29 SA	29.0	18
ICK SMD E 22 SA	22.3	21			

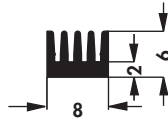

art. no.	↔ [mm]	R _{th} [K/W]	art. no.	↔ [mm]	R _{th} [K/W]
ICK SMD F 8 ...	8	74	ICK SMD F 19 ...	19	37
ICK SMD F 10 ...	10	71	ICK SMD F 21 ...	21	33
ICK SMD F 17 SA	17	42	ICK SMD F 26 ...	26	26

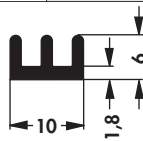

art. no.	↔ [mm]	R _{th} [K/W]	art. no.	↔ [mm]	R _{th} [K/W]
ICK SMD G 8 MI	8	73	ICK SMD G 17 SA	17	41
ICK SMD G 10 ...	10	70	ICK SMD G 19 SA	19	36
ICK SMD G 13 SA	13	61	ICK SMD G 21 ...	21	32

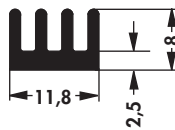

art. no.	↔ [mm]	R _{th} [K/W]	art. no.	↔ [mm]	R _{th} [K/W]
ICK SMD H 8 ...	8	33.0	ICK SMD H 19 SA	19	23.0
ICK SMD H 10 ...	10	29.0	ICK SMD H 25 ...	25	20.0
ICK SMD H 17 ...	17	24.5			

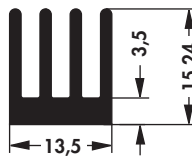

art. no.	↔ [mm]	R _{th} [K/W]	art. no.	↔ [mm]	R _{th} [K/W]
ICK SMD K 8 ...	8	25.6	ICK SMD K 17 ...	17	19.4
ICK SMD K 10 SA	10	23.4	ICK SMD K 19 ...	19	18.0
ICK SMD K 13 ...	13	21.5	ICK SMD K 21 ...	21	16.5



art. no.	↔ [mm]	R _{th} [K/W]	art. no.	↔ [mm]	R _{th} [K/W]
ICK SMD M 8 SA	8	72	ICK SMD M 19 SA	19	35
ICK SMD M 10 SA	10	66	ICK SMD M 21 SA	21	31
ICK SMD M 17 MI	17	40			

please indicate: ... surface
SA = black anodised
MI = solderable surface

Extruded heatsinks
 ICK S 10 x 10 x 6,5
 Insulating clamping parts
 Thermal conductive glue

→ A 22 – 83
 → B 21 – 28
 → E 45
 → E 23 – 24

Thermally conductive foil
 Thermal conductive paste
 Hole pattern
 Technical introduction

→ E 5 – 15
 → E 21 – 22
 → A 21
 → A 2 – 8

heatsink for SMD

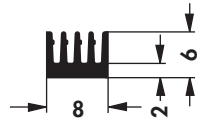

art. no.	↔ [mm]	R _{th} [K/W]	art. no.	↔ [mm]	R _{th} [K/W]
ICK SMD N 8 ...	8	74	ICK SMD N 19 ...	19	37
ICK SMD N 10 ...	10	71	ICK SMD N 21 ...	21	33
ICK SMD N 17 ...	17	42	ICK SMD N 26 ...	26	26

please indicate: ... surface
SA = black anodised
MI = solderable surface

Sample box SMD heatsinks

– contains an assortment of SMD heatsinks with anodised and solderable surface as well as thermally conductive glue (**WLK**) and double-sided adhesive thermal foil (**WLF**)



art. no.
ICK SMD BOX 1

B 55





Extruded heatsinks
 ICK S 10 x 10 x 6,5
 Insulating clamping parts
 Thermal conductive glue

→ A 22 – 83
 → B 21 – 28
 → E 45
 → E 23 – 24

Thermally conductive foil
 Thermal conductive paste
 Hole pattern
 Technical introduction

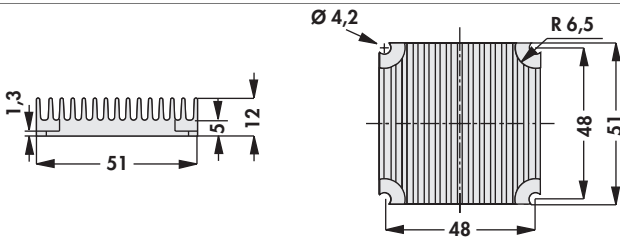
→ E 5 – 15
 → E 21 – 22
 → A 21
 → A 2 – 8

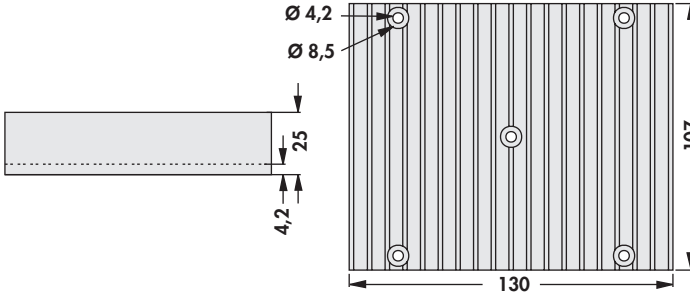
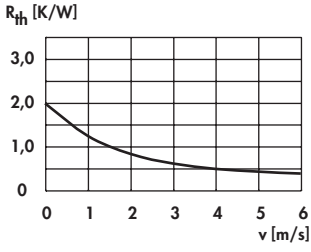
Passive heatsinks for processors

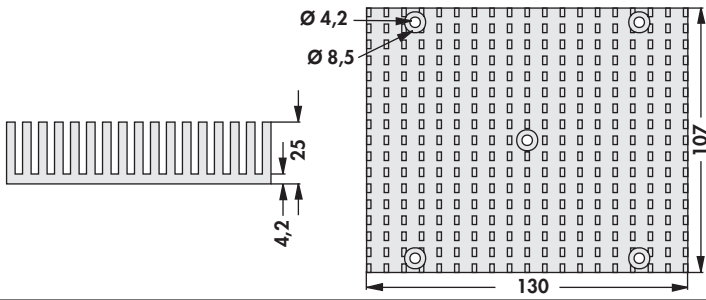
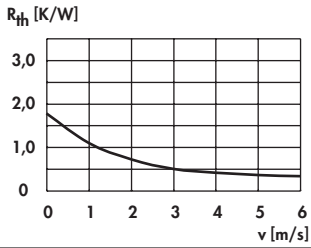
		
art. no. ICK PPC 51	R_{th} [K/W] 8.1	suitable for processor type Power PC
		
art. no. ICK PEN 3 XE	R_{th} [K/W] 2	suitable for processor type Intel® Pentium® III-Xeon™ Slot II Format
		
art. no. ICK PEN 3 XE 1	R_{th} [K/W] 1.8	suitable for processor type Intel® Pentium® III-Xeon™ Slot II Format

Heatsink specially for Q7 "Embedded-Boards"

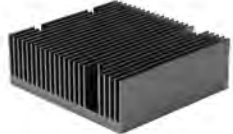
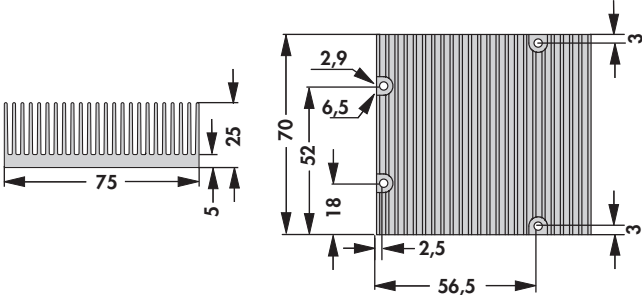
		
art. no. ICK EM 25	R_{th} [K/W] 3.9	suitable for processor type Q7 Board

Passive heatsinks for processors

– customer specific versions and modifications on request

art. no.	R_{th} [K/W]	suitable for processor type	dim. [mm]			
			A	B	C	D
ICK PEN 38 F	4.0	AMD® K6-III/ IDT W2A/ MMX/ IDT C6/ Intel® Pentium®/ AMD® K6-2	49.5	49.5	38	5.0
ICK PEN 38 W	4.0	AMD® K6-III/ IDT W2A/ MMX/ IDT C6/ Intel® Pentium®/ AMD® K6-2	49.5	49.5	38	5.0
ICK PEN 45 W	3.5	AMD® K6-III/ IDT W2A/ MMX/ IDT C6/ Intel® Pentium®/ AMD® K6-2	50.0	50.0	45	3.5

art. no.	R_{th} [K/W]	suitable for processor type	dim. [mm]			
			A	B	C	D
ICK PRO 40 W	2.7	Intel® Pentium® PRO	65	67.5	40	4.5

F = with double-sided thermally conductive adhesive foil
W = for thermally conductive adhesive (please order separately)
WLK ... → E 23

art. no.	R_{th} [K/W]	suitable for processor type
ICK PEN 3 FC	3.5	Intel® Pentium® III FC PGA (Mendocino, Coppermine)

fixing method: K = with fixing clamp (incl. one-sided adherent thermal foil)

B 57

- | | | | |
|--------------------------------------|-------------|-------------------------------------|-------------|
| Fan cooler for Intel PentiumIII/Xeon | → B 60 | Heatsinks for Q7 "Embedded-Boards"→ | B 56 |
| Fan cooler, universal | → B 58 | Heatsinks for BGA | → B 17 – 20 |
| Attachable heatsinks | → C 10 – 16 | Heatsinks for PGA | → B 11 – 16 |
| Thermal conductive material | → E 2 – 24 | Technical introduction | → A 2 – 8 |

Active heatsinks for processors

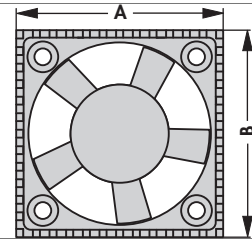
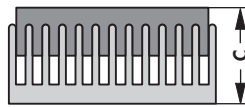
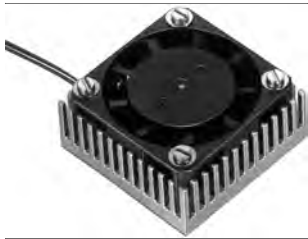

art. no.	R _{th} [K/W]	suitable for processor type	dim. [mm]		
			A	B	C
LA ICK 15 x 15 F 05	2.3	universal	37.92	38.10	20
LA ICK 15 x 15 F 12	2.3	universal	37.92	38.10	20
LA ICK 17 x 17 F 12	1.6	universal	43.10	43.10	20
LA ICK 17 x 17 F 12 A	1.6	universal	43.10	43.10	20
LA ICK 17 x 17 W 05	1.6	universal	43.10	43.10	20
LA ICK 17 x 17 W 12	1.6	universal	43.10	43.10	20
LA ICK 18 x 18 F 12	1.5	universal	45.70	45.70	20
LA ICK 18 x 18 W 12	1.5	universal	45.70	45.70	20
LA ICK 21 x 21 F 05	1.4	universal	53.34	53.34	20
LA ICK 21 x 21 F 12	1.4	universal	53.34	53.34	20
LA ICK 21 x 21 W 05	1.4	universal	53.34	53.34	20
LA ICK 21 x 21 W 12	1.4	universal	53.34	53.34	20

used fans:

5 Volt = **Sepa MFB 25 F 05 L / MFB 40 H 05 / MFB 40 H 05 A**;

12 Volt = **Sepa MFB 25 F 12 / MFB 40 H 12 / MFB 40 H 12 A**

F = with double-sided thermally conductive adhesive foil

W = for thermally conductive adhesive (please order separately) **WLK ...** → E 23

A = alarm exit

Active heatsinks for processors



LA ICK PEN 8



LA ICK PEN 16



LA ICK PEN 18



LA ICK PEN 38



LA ICK PRO 25

– easy assembly on ZIF socket by fixing clamp

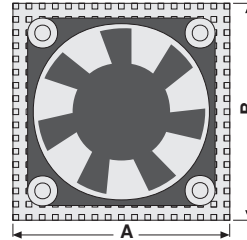
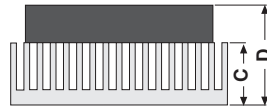

art. no.	R _{th} [K/W]	suitable for processor type	dim. [mm]			
			A	B	C	D
LA ICK PEN 8 F 05	2.50	AMD® K6-III/ IDT W2A/ Cyrix MII and similar/ MMX/ IDT C6/ Intel® Pentium®/ AMD® K6-2	50.8	50.8	8.00	9.00
LA ICK PEN 8 F 12	2.50	AMD® K6-III/ IDT W2A/ Cyrix MII and similar/ MMX/ IDT C6/ Intel® Pentium®/ AMD® K6-2	50.8	50.8	8.00	9.00
LA ICK PEN 8 W 05	2.50	AMD® K6-III/ IDT W2A/ Cyrix MII and similar/ MMX/ IDT C6/ Intel® Pentium®/ AMD® K6-2	50.8	50.8	8.00	9.00
LA ICK PEN 8 W 12	2.50	AMD® K6-III/ IDT W2A/ Cyrix MII and similar/ MMX/ IDT C6/ Intel® Pentium®/ AMD® K6-2	50.8	50.8	8.00	9.00
LA ICK PEN 16 K 12	1.20	AMD® K6-III/ IDT W2A/ Cyrix MII and similar/ MMX/ IDT C6/ Intel® Pentium®/ AMD® K6-2	50.8	50.8	16.51	26.51
LA ICK PEN 16 W 12	1.20	AMD® K6-III/ IDT W2A/ Cyrix MII and similar/ MMX/ IDT C6/ Intel® Pentium®/ AMD® K6-2	50.8	50.8	16.51	26.51
LA ICK PEN 16 W 12 A	1.20	AMD® K6-III/ IDT W2A/ Cyrix MII and similar/ MMX/ IDT C6/ Intel® Pentium®/ AMD® K6-2	50.8	50.8	16.51	26.51
LA ICK PEN 18 W 12	1.60	AMD® K6-III/ IDT W2A/ Cyrix MII and similar/ MMX/ IDT C6/ Intel® Pentium®/ AMD® K6-2	50.8	50.8	8.00	18.00
LA ICK PEN 38 W 12	1.10	AMD® K6-III/ IDT W2A/ Cyrix MII and similar/ MMX/ IDT C6/ Intel® Pentium®/ AMD® K6-2	49.5	49.5	38.00	48.00
LA ICK PRO 25 F 12	0.97	Intel® Pentium® PRO	63.5	67.5	25.00	35.00

used fans: 5 Volt = **Sepa MFB 50 E 05**; 12 Volt = **Sepa MFB 50 E 12/ Sepa MFB 50 E 12 A**;

LA ICK PEN 8: 5 Volt = **Sepa HFB 44 X 05 A**; 12 Volt = **Sepa HFB 44 B 12 A**

K = with fixing clamp (incl. one-sided adherent conductive foil)

F = with double-sided thermally conductive adhesive foil

W = for thermally conductive adhesive (please order separately) **WLK ...** → E 23

A = alarm exit

Active heatsinks for processors

– incl. one-sided adherent thermal foil

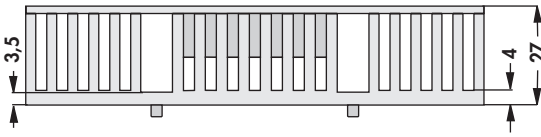
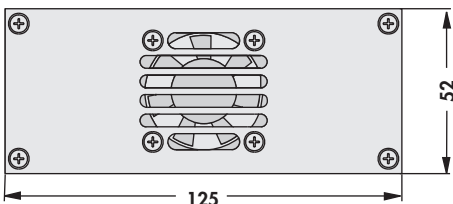
		
art. no.	R_{th} [K/W]	suitable for processor type
LA ICK PEN 2 K 12 ...	1.2	Intel® Pentium® II/ AMD® Athlon®
please indicate:	... accessory (optional) SM = molex connection plug	

utilized fans: 12 Volt = Sepa MFB 40 H 12

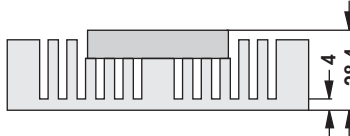
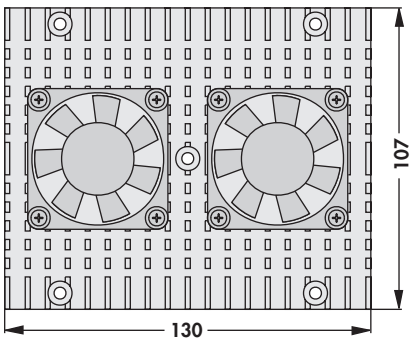
		
art. no.	R_{th} [K/W]	suitable for processor type
LA ICK PEN 3 XE	0.8	Intel® Pentium® III-Xeon™
please indicate:	... accessory (optional) A = alarm exit SM = molex connection plug	

fixing method: SB = screw fixing

utilized fans: 12 Volt = Sepa MFB 50 E 12

- with copper base plate
- customer specific designs and modifications on request

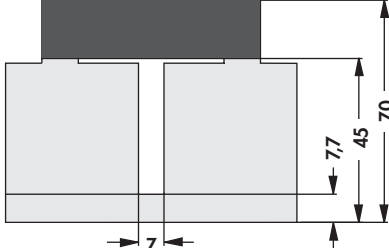
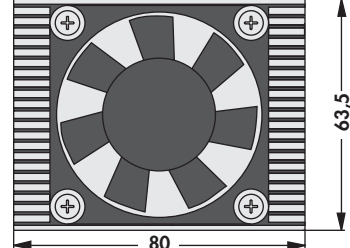
		
art. no.	R_{th} [K/W]	suitable for processor type
LA ICK PEN 4 1 K	0.6	Intel® Pentium® IV
please indicate:	... accessory (optional) SM = molex connection plug	

fixing method: K = with fixing clamp

operating voltage of the fan motor: 12 Volt (Papst 612 NHH)

Heatsinks for BGA → B 17 – 20
Heatsinks for Q7 "Embedded-Boards" → B 56
Fan cooler, universal → B 58
Heatsinks for Pentium PRO → B 57

Heatsinks for P II-Mobile Module → B 56
Fan cooler for Pentium IV → B 60
Thermal conductive material → E 2 – 24
Technical introduction → A 2 – 8

B 60

A

B

C

D

E

F

G

H

I

K

L

M

N

Technical data of the fans



molex crimp case series: 6471 ; molex crimp terminals: 2759

– Sepa-fan 24 h BURN-IN tested

5 volt fan

	Sepa MFB 25 F 05 L	Sepa MFB 40 H 05	Sepa MFB 40 H 05 A	Sepa MFB 50 E 05	Sepa HFB 44 X 05 A	ebmpapst 405 F
circuit voltage	4.5...5.5 V DC	4.5...5.5 V DC	4.5...5.5 V DC	4.5...5.5 V DC	4.5...5.5 V DC	4.5...5.5 V DC
bearing type	double ball bearing	double ball bearing	double ball bearing	double ball bearing	ball bearing	double slide bearing
fan dimensions	25x25x10 mm	40x40x10 mm	40x40x10 mm	50x50x10 mm	44x44x6.2 mm	40x40x10 mm
cur. consumpt.	90 mA	90 mA	90 mA	50 mA	90 mA	140 mA
max. iutial current	170 mA	250 mA	250 mA	120 mA	160 mA	
max. volume flow	46 l/min 2.8 m ³ /h	184 l/min 11 m ³ /h	184 l/min 11 m ³ /h	169 l/min 10.1 m ³ /h	50 l/min 3 m ³ /h	132 l/min 8 m ³ /h
max. static pressure	2.2 mmH ₂ O 22 Pa	3.1mm H ₂ O 30.5 Pa	3.1mm H ₂ O 30.5 Pa	1.6mm H ₂ O 15.6 Pa	2.6mm H ₂ O 25.5 Pa	3.06mm H ₂ O 30 Pa
noise level	18 dB(A), 1 m lateral	24 dB(A), 1 m lateral	24 dB(A), 1 m lateral	17 dB(A), 1 m lateral	28 dB(A), 1 m lateral	22.1 dB(A), 1 m lateral
temperature range	-10°C ... +85°C	-40°C... +80°C	-40°C... +80°C	-10°C... +70°C	-40°C... +80°C	-20°C... +70°C
failure rate (L₁₀)	95,000 h	95,000 h	95,000 h	95,000 h	95,000 h	45,000 h (20°C)
MTBF	280,000 h (20°C)	280,000 h (20°C)	280,000 h (20°C)	280,000 h (20°C)	280,000 h (20°C)	
weight	8 g	13 g	13 g	19 g	7 g	17 g
cases	plastic PBT (UL E54695)	plastic PBT (UL E54695)	plastic PBT (UL E54695)	plastic PBT (UL E54695)	plastic PBT (UL E54695)	plastic PBT (UL E38324)

12 volt fan

	Sepa MFB 25 F 12	Sepa MFB 40 H 12	Sepa MFB 40 H 12 A	Sepa MFB 50 E 12	Sepa HFB 44 B 12 A	ebmpapst 412 F
circuit voltage	10.2...13.8 V DC	10.2...13.8 V DC	10.2...13.8 V DC	10.2...13.8 V DC	10.2...13.8 V DC	10-14 V DC
bearing type	double ball bearing	double ball bearing	double ball bearing	ball bearing	ball bearing	double slide bearing
fan dimensions	25x25x10 mm	40x40x10 mm	40x40x10 mm	50x50x10 mm	44x44x6.2 mm	40x40x10 mm
cur. consumpt.	70 mA	50 mA	50 mA	60 mA	40 mA	60 mA
max. iutial current	150 mA	130 mA	130 mA	140 mA	70 mA	
max. volume flow	70 l/min 4.1 m ³ /h	173 l/min 10.3 m ³ /h	173 l/min 10.3 m ³ /h	238 l/min 14.3 m ³ /h	50 l/min 3 m ³ /h	132 l/min 8 m ³ /h
max. static pressure	2.24mm H ₂ O 41.5 Pa	2.9 mmH ₂ O 28.5 Pa	2.9 mmH ₂ O 28.5 Pa	2.7mm H ₂ O 26.9 Pa	2.6mm H ₂ O 25.5 Pa	3.06mm H ₂ O 30 Pa
noise level	23 dB(A), 1 m lateral	24 dB(A), 1 m lateral	21 dB(A), 1 m lateral	22 dB(A), 1 m lateral	28 dB(A), 1 m lateral	22.1 dB(A), 1 m lateral
temperature range	-40°C... +80°C	-40°C... +80°C	-40°C... +80°C	-10°C... +70°C	-40°C... +80°C	-20°C... +70°C
failure rate (L₁₀)	95,000 h	95,000 h	95,000 h	95,000 h	95,000 h	45,000 h (20°C)
MTBF	280,000 h (20°C)	280,000 h (20°C)	280,000 h (20°C)	280,000 h (20°C)	280,000 h (20°C)	
weight	8 g	13 g	13 g	19 g	20 g	17 g
cases	plastic PBT (UL E54695)	plastic PBT (UL E54695)	plastic PBT (UL E54695)	plastic PBT (UL E54695)	steel/aluminium (UL E54695)	plastic PBT (UL E38324)

Fans with pulse output - Technical data of fans with pulse output:

- pulse output for activation of the alarm control
- pulse similar to a square pulse with three times the frequency of the rotor speed
- when the rotor is blocked, the output signal may be L (≤ 0.8 V) or H ($V_{cc}-1$ V)
- the pulse output must not be connected to GND or Vcc withoutb protective resistor (> 10 K)
- in order to avoid short circuits, the pulse output not being used must be insulated



Finger shaped heatsinks for power semiconductors

- specially compatible for power semiconductors in a TO-case
- made as a bent sheet metal part or die cast heatsink made of aluminium
- aligned heatsink contours for the best heat dissipation
- direct screwing of the component to the heatsink on the PCB



Attachable heatsinks

- made of aluminium or copper material
- solderable surface coating
- integrated spring clip for easy and fast mounting of the transistor
- secure hold of the component due to optimized spring force and geometry
- customer specific version upon request

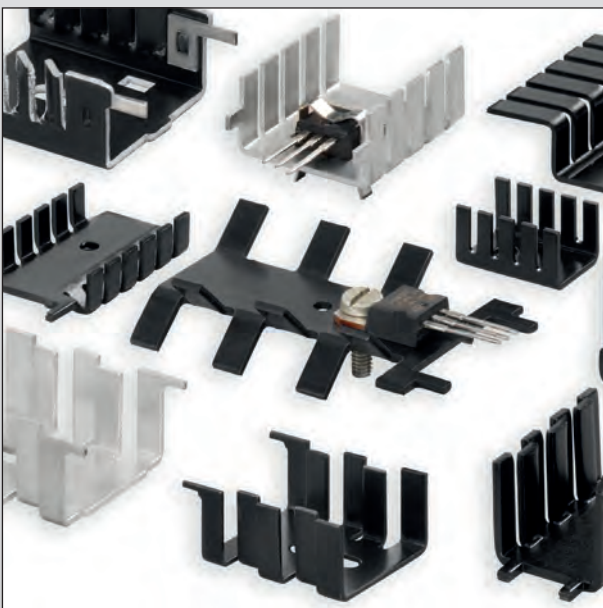

Finger shaped heatsinks for transistors

- effective heat dissipation of transistors
- efficient radiation of heat at a horizontal or vertical mounting position
- component fastening by means of screws or special transistor retaining springs
- solder mounting by means of integrated solder pins and solderable surfaces





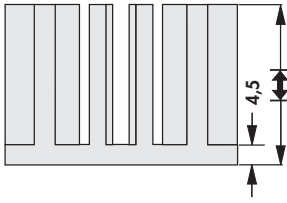
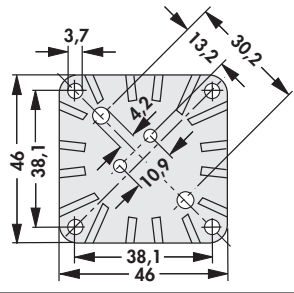

Miniature heatsinks

- for TO 5, SOT 82, D PAK and similar semiconductors
- made of aluminium, phosphorus bronze or copper
- simple mounting by direct plugging or soldering of the heatsink
- special types of packaging such as tape & reel, magazine or tray upon request
- versions and designs for your application

Finger shaped heatsinks for power semiconductors

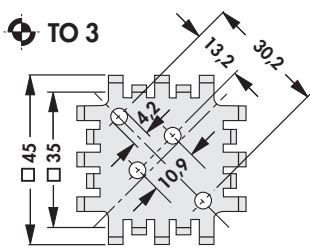
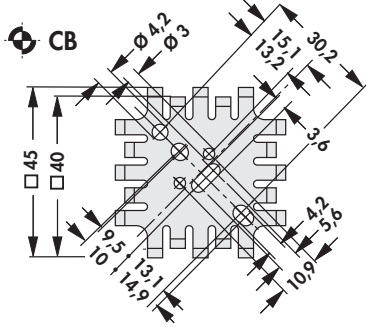
			
art. no.	\pm [mm]	R_{th} [K/W]	\diamond
FK 254 SA 3	25.4	5.8	TO 3
FK 318 SA	31.8	4.8	without
FK 318 SA 3	31.8	4.8	TO 3
material:	die-casting aluminium		
surface:	black lacquered		

			
art. no.	\pm [mm]	R_{th} [K/W]	\diamond
FK 201 SA	25.4	6	without
FK 201 SA 3	25.4	6	TO 3
FK 201 SA CB	25.4	6	CB
FK 202 SA	12.7	8	without
FK 202 SA 3	12.7	8	TO 3
FK 202 SA CB	12.7	8	CB

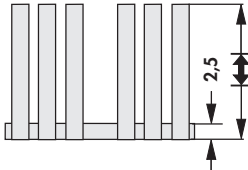
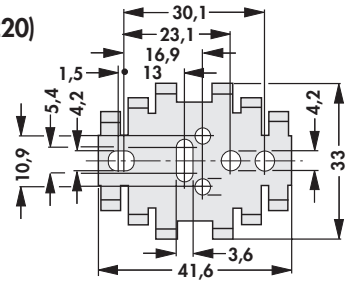
			
art. no.	\pm [mm]	R_{th} [K/W]	\diamond
FK 205 SA L	31.8	9.0	L
FK 206 SA L	25.4	10.5	L
FK 207 SA L	19.1	12.0	L
FK 208 SA L	12.7	14.0	L
material:	aluminium		
surface:	black anodised		

Finger shaped heatsinks for power semiconductors

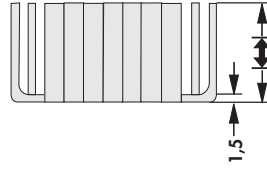

FK 223 SA 3

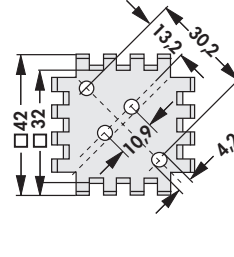

FK 223 SA CB

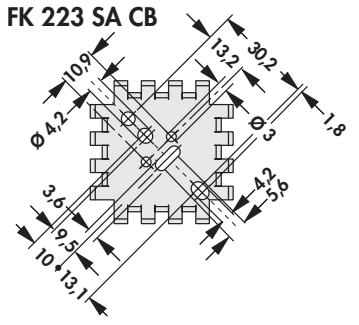

art. no.	h [mm]	R _{th} [K/W]	⊗
FK 223 SA	17	6.8	without
FK 223 SA 3	17	6.8	TO 3
FK 223 SA CB	17	6.8	CB

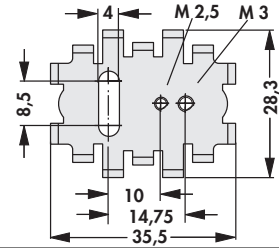
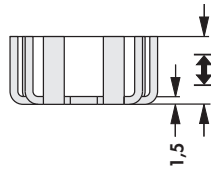

art. no.	h [mm]	R _{th} [K/W]	⊗
FK 217 SA CB 2	13	16	CB 2 (SOT 32; TO 220)

material:	aluminium
surface:	black anodised

C 3

Attachable heatsinks
Heatsinks for TO 5 and TO 18
Heatsinks for D PAK
Aluminium oxide wafers

→ C 10 – 14
→ C 17 – 19
→ C 21 – 117
→ E 17 – 18

Mounts
Insulating caps
Thermal conductive material
Technical introduction

→ E 44 – 48
→ E 51
→ E 2 – 24
→ A 2 – 8

Heatsinks for transistors in plastic case

– for semiconductor screw-assembly, horizontal

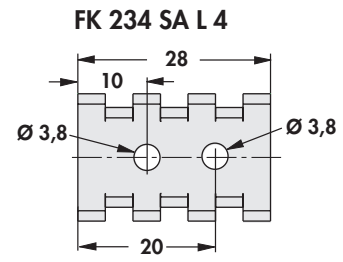
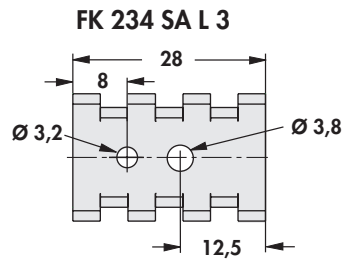
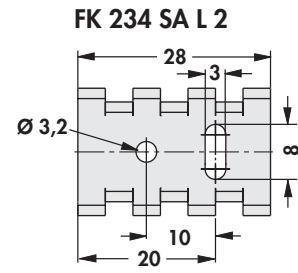
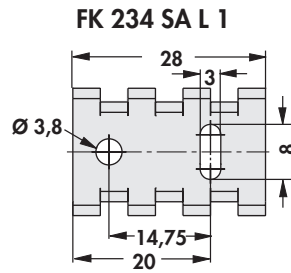
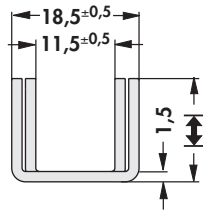

art. no.	h [mm]	R _{th} [K/W]	⊗
FK 234 SA L 1	15	17	TO 220
FK 234 SA L 2	15	17	SOT 32
FK 234 SA L 3	15	17	CB
FK 234 SA L 4	15	17	CB
material:	aluminium		
surface:	black anodised		

– for semiconductor screw-assembly, vertical

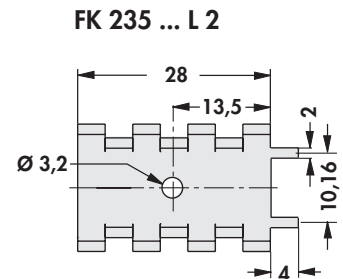
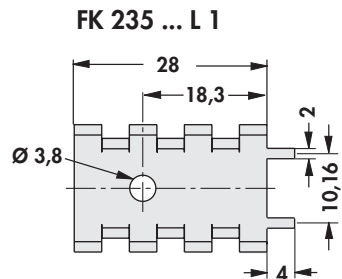
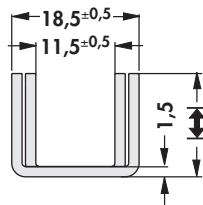

art. no.	h [mm]	R _{th} [K/W]	⊗
FK 235 MI L 1	15	16	TO 220
FK 235 MI L 2	15	16	SOT 32
FK 235 SA L 1	15	16	TO 220
FK 235 SA L 2	15	16	SOT 32
material:	aluminium		
surface:	solderable surface/ black anodised		







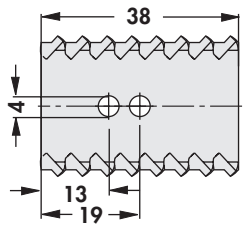
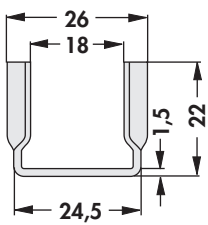

Attachable heatsinks
Heatsinks for TO 5 and TO 18
Heatsinks for D PAK
Aluminium oxide wafers

→ C 10 – 14
→ C 17 – 19
→ C 21
→ E 17 – 18

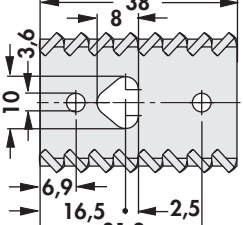
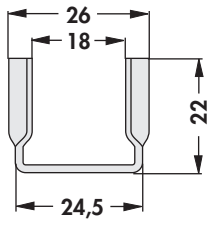
Mounts
Insulating caps
Thermal conductive material
Technical introduction

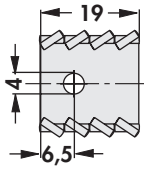
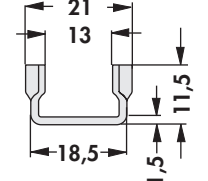
→ E 44
→ E 51
→ E 2 – 24
→ A 2 – 8

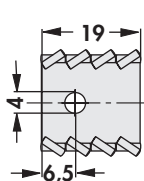
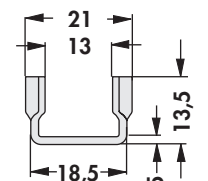
Heatsinks for transistors in plastic case

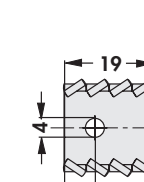
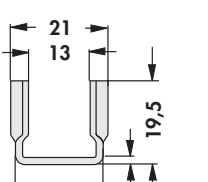



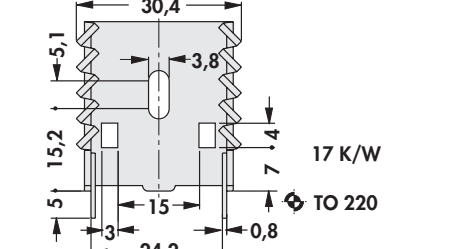
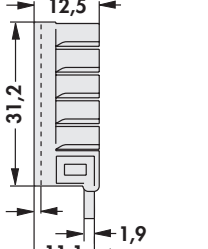



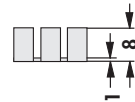
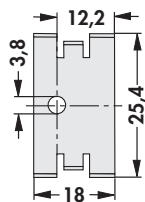

<p>art. no.</p> <p>FK 225 SA L 1</p>			<p>9,9 K/W</p> <p>TO 220</p>	
<p>art. no.</p> <p>FK 225 SA L 2</p>			<p>9,9 K/W</p> <p>TO 220</p>	
<p>art. no.</p> <p>FK 228 SA L 1</p>			<p>30 K/W</p> <p>TO 220</p>	
<p>art. no.</p> <p>FK 229 SA L 1</p>			<p>27 K/W</p> <p>TO 220</p>	
<p>art. no.</p> <p>FK 230 SA L 1</p>			<p>21 K/W</p> <p>TO 220</p>	

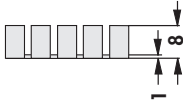
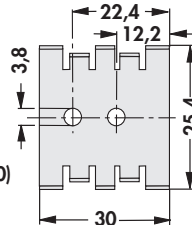
<p>material:</p>	<p>aluminium</p>
<p>surface:</p>	<p>black anodised</p>

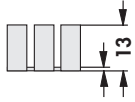
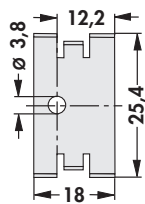

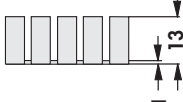
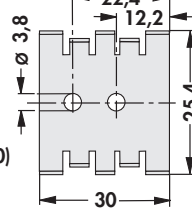

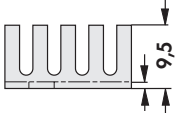
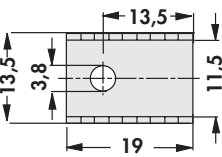

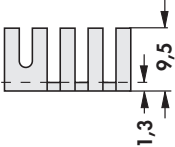
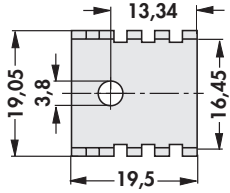



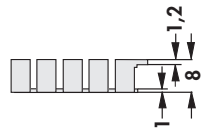
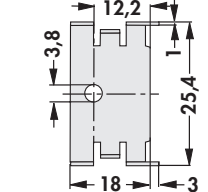

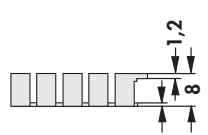
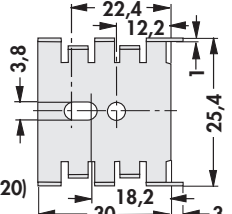
<p>art. no.</p> <p>FK 249 SA 220</p>			
---	---	--	---

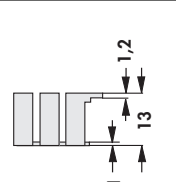
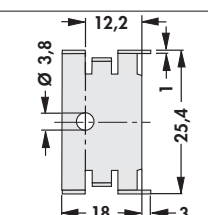
<p>material:</p>	<p>aluminium</p>
<p>surface:</p>	<p>black passivated, solder pins tin plated</p>

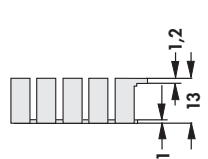
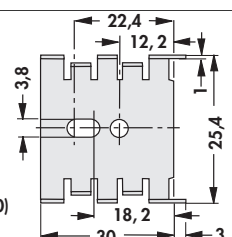

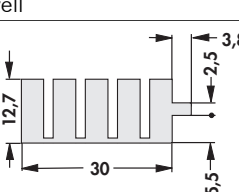
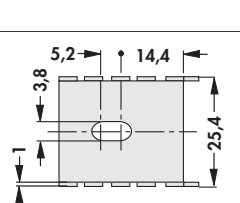

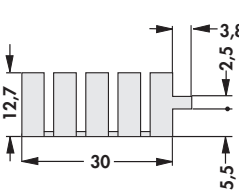
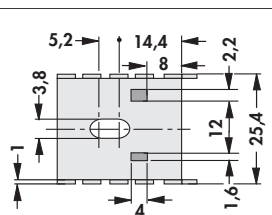

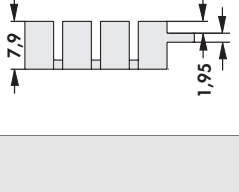
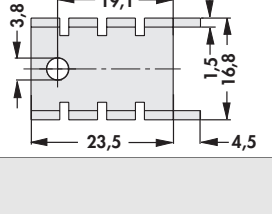

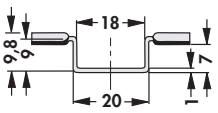
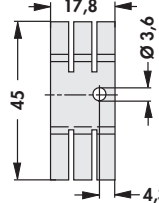

Heatsinks for transistors in plastic case

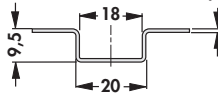
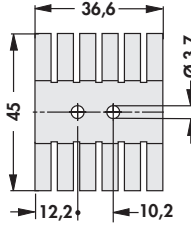
<p>art. no.</p>			<p>25 K/W ⚙ SOT 32</p>	
<p>FK 209 SA 32</p>		<p>available without hole pattern as well</p>		
<p>art. no.</p>			<p>18 K/W ⚙ CB (SOT 32 + TO 220)</p>	
<p>FK 210 SA CB</p>		<p>available without hole pattern as well</p>		
<p>art. no.</p>			<p>21 K/W ⚙ SOT 32</p>	
<p>FK 213 SA 32</p>		<p>available without hole pattern as well</p>		
<p>art. no.</p>			<p>15 K/W ⚙ CB (SOT 32 + TO 220)</p>	
<p>FK 214 SA CB</p>		<p>available without hole pattern as well</p>		
<p>art. no.</p>			<p>24 K/W ⚙ TO 220</p>	
<p>FK 231 SA 220</p>				
<p>art. no.</p>			<p>24 K/W ⚙ SOT 32</p>	
<p>FK 239 SA 32</p>				
<p>material:</p>		<p>aluminium</p>		
<p>surface:</p>		<p>black anodised</p>		

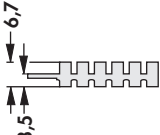
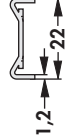
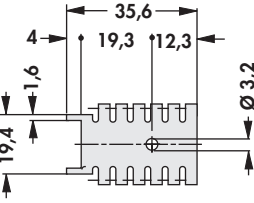

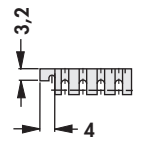
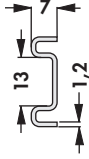
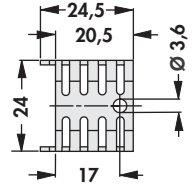

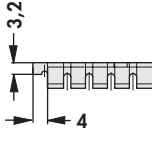
Heatsinks for transistors in plastic case

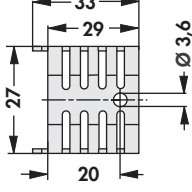
<p>art. no.</p>		 <p>25 K/W SOT 32</p>	
<p>FK 211 32 ... available without hole pattern as well</p>			
<p>art. no.</p>		 <p>18 K/W CB (SOT 32 + TO 220)</p>	
<p>FK 212 CB ... available without hole pattern as well</p>			
<p>art. no.</p>		 <p>21 K/W SOT 32</p>	
<p>FK 215 32 ... available without hole pattern as well</p>			
<p>art. no.</p>		 <p>15 K/W CB (SOT 32 + TO 220)</p>	
<p>FK 216 CB available without hole pattern as well</p>			
<p>art. no.</p>		 <p>20 K/W TO 220</p>	
<p>FK 222 ... available without hole pattern as well</p>			
<p>art. no.</p>		 <p>20 K/W TO 220</p>	
<p>FK 222 THF ...</p>			
<p>art. no.</p>		 <p>22 K/W TO 220</p>	
<p>FK 247 220 ...</p>			
<p>please indicate: ... surface SA = black anodised MI = solderable surface</p>			
<p>material:</p>	<p>aluminium</p>		

Heatsinks for transistors in plastic case

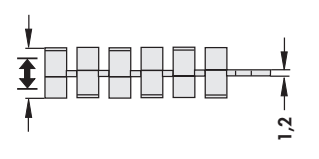
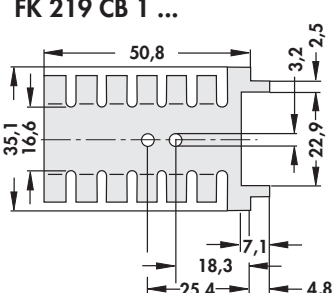
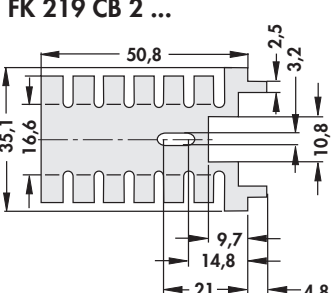
<p>art. no.</p> <p>FK 227 SA L 1</p>		 <p>22 K/W TO 220</p>	
<p>art. no.</p> <p>FK 238 SA L 1</p>		 <p>12 K/W TO 220</p>	
<p>material:</p>		<p>aluminium</p>	
<p>surface:</p>		<p>black anodised</p>	
<p>art. no.</p> <p>FK 218 32 ...</p>		  <p>21 K/W SOT 32 TO 220</p>	
<p>art. no.</p> <p>FK 232 220 ...</p>		  <p>21 K/W TO 220</p>	
<p>art. no.</p> <p>FK 233 220 ...</p>		  <p>20,2 K/W TO 220</p>	
<p>please indicate:</p>		<p>... surface SA = black anodised MI = solderable surface</p>	
<p>material:</p>		<p>aluminium</p>	

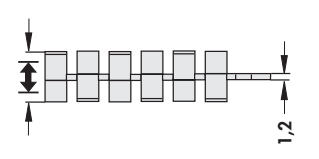
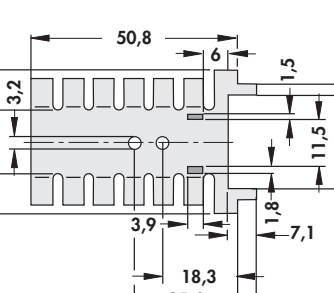
Heatsinks for transistors in plastic case

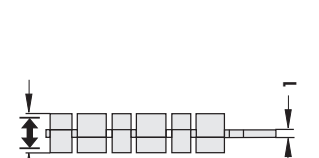
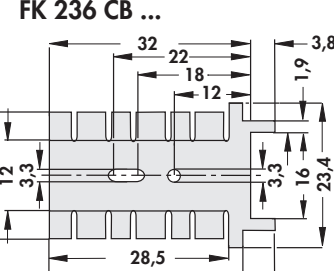
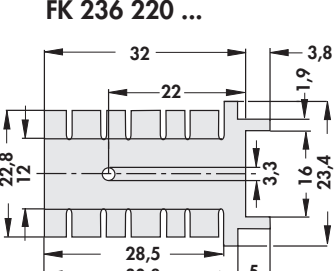
		<p>FK 219 CB 1 ...</p> 	<p>FK 219 CB 2 ...</p> 
<p>art. no.</p>	<p>\pm [mm]</p>	<p>R_{th} [K/W]</p>	<p>\diamond</p>
<p>FK 219 CB 1 ...</p>	<p>12.6</p>	<p>14</p>	<p>CB 1 (TO 220)</p>
<p>FK 219 CB 2 ...</p>	<p>12.6</p>	<p>14</p>	<p>CB 2 (TO 220)</p>
			
<p>art. no.</p>	<p>\pm [mm]</p>	<p>R_{th} [K/W]</p>	<p>\diamond</p>
<p>FK 219 CB 3 ...</p>	<p>12.6</p>	<p>14</p>	<p>CB 3 (TO 220)</p>
		<p>FK 236 CB ...</p> 	<p>FK 236 220 ...</p> 
<p>art. no.</p>	<p>\pm [mm]</p>	<p>R_{th} [K/W]</p>	<p>\diamond</p>
<p>FK 236 220 ...</p>	<p>5</p>	<p>18</p>	<p>TO 220</p>
<p>FK 236 CB ...</p>	<p>5</p>	<p>18</p>	<p>CB</p>
<p>please indicate: ... surface SA = black anodised MI = solderable surface</p>			
<p>material:</p>	<p>aluminium</p>		

Attachable heatsinks

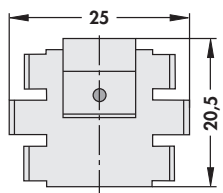
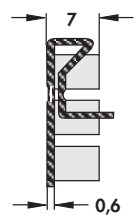
		
art. no.	R_{th} [K/W]	⌀
FK 220 SA 220	25	TO 220
material:	aluminium	
surface:	black anodised	

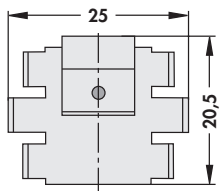
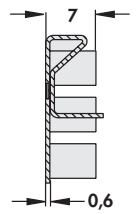

– for transistors with thin bottom thickness (0.5 mm)

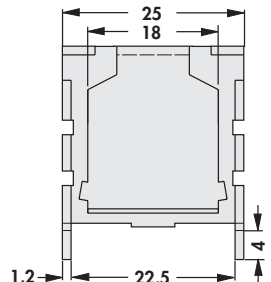
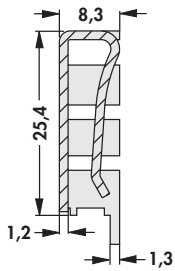
		
art. no.	R_{th} [K/W]	⌀
FK 258 SA 220	25	TO 220
material:	aluminium	
surface:	black anodised	

		
art. no.	R_{th} [K/W]	⌀
FK 224 ... P SIP	18	P SIP
please indicate:	... surface SA = black anodised MI = solderable surface	
material:	aluminium	

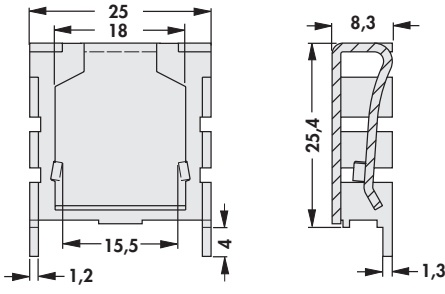
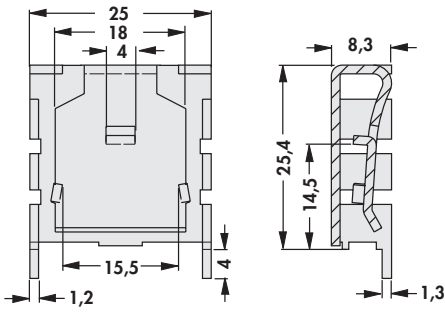
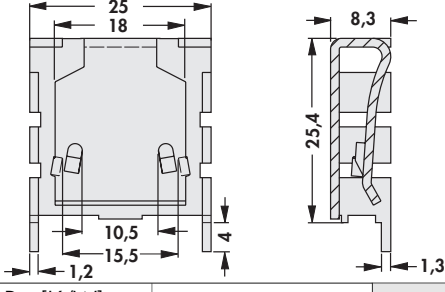
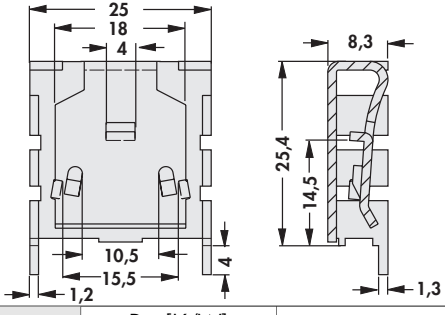

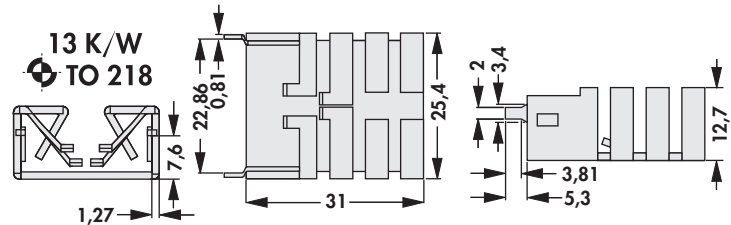

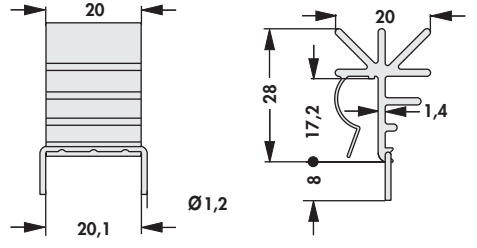



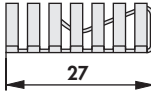
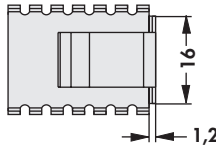
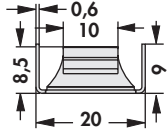

Attachable heatsinks

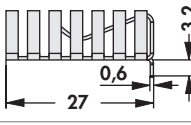
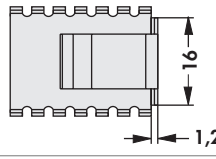
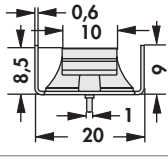
	FK 224 ... 218 1 		FK 224 ... 218 2 			
	FK 224 ... 220 1 		FK 224 ... 220 2 			
	art. no.	R_{th} [K/W]	\varnothing	art. no.	R_{th} [K/W]	\varnothing
	FK 224 ... 218 1	18	TO 218	FK 224 ... 220 1	18	TO 220
FK 224 ... 218 2	18	TO 218	FK 224 ... 220 2	18	TO 220	
please indicate: ... surface SA = black anodised MI = solderable surface						
material:		aluminium				

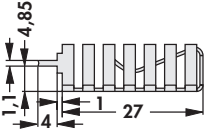
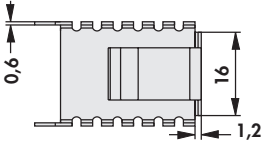
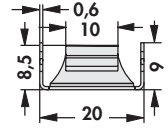
art. no.		
FK 241 SA 218 V	with tin-plated soldering lug for direct soldering onto circuit board, for vertical installation	
art. no.		
FK 248 SA 220		
material:		aluminium
surface:		black anodised, solder pins tin plated

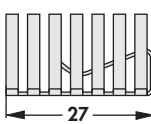
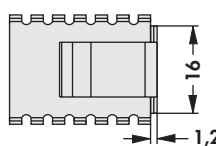
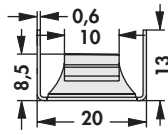
Attachable heatsinks

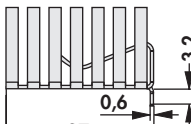
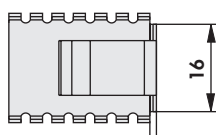
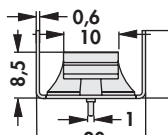
- universal clip on heatsinks for type TO 218, TO 229, TO 247, TO 248, SIP-Mulitwatt and similar
- easy assembly by pushing the heatsink onto the component
- for vertical and horizontal fastening by soldering
- fin height variations on request
- special design accord. to customized specification

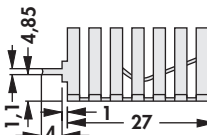
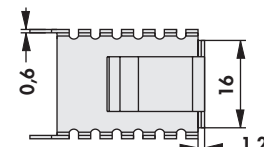
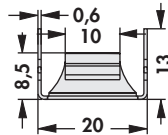
art. no.		20,2 K/W			
FK 245 MI 247 O	without soldering lug				
art. no.		20,5 K/W			
FK 245 MI 247 H	with soldering lug for horizontal mounting				
art. no.		19,7 K/W			
FK 245 MI 247 V	with soldering lug for vertical mounting				
art. no.		18,4 K/W			
FK 243 MI 247 O	without soldering lug				
art. no.		19 K/W			
FK 243 MI 247 H	with soldering lug for horizontal mounting				
art. no.		18,4 K/W			
FK 243 MI 247 V	with soldering lug for vertical mounting				
material:	copper (Cu)				
surface:	solderable surface				
material thickness:	0.6 mm				

Heatsinks for D PAK
Heatsinks for transistors
Kapton insulator washers
Vibration dampers

→ C 21
→ C 4 - 9
→ E 16
→ E 41



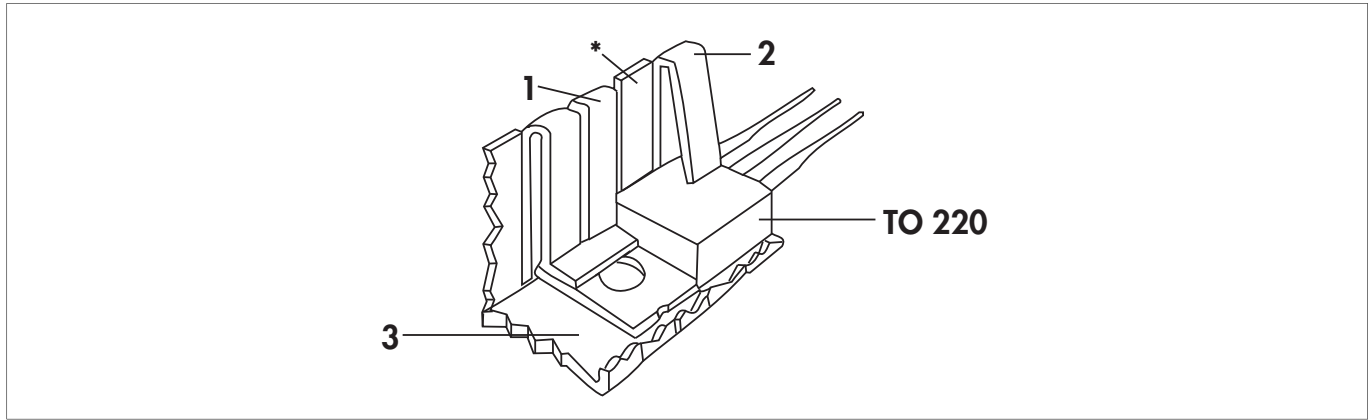

Vibration dampers
U-shaped heatsink
Aluminium oxide wafers
Technical introduction

→ E 41
→ A 123 - 124
→ E 17 - 18
→ A 2 - 8



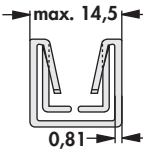
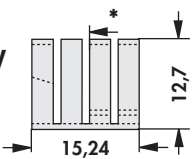
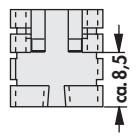

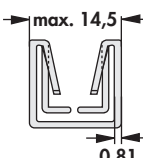
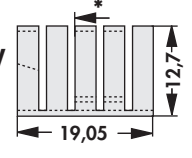
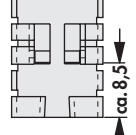
Attachable heatsinks

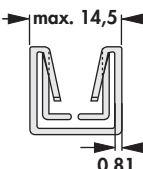
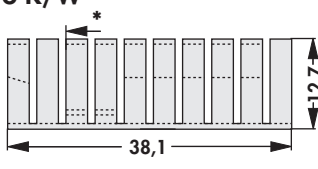
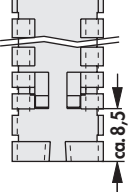



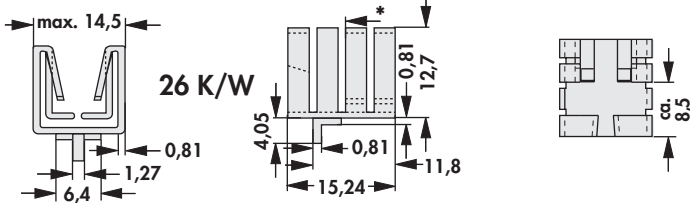

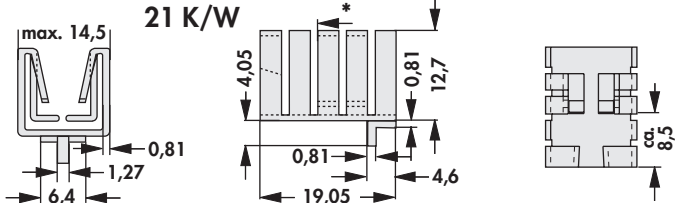
- narrow version with better thermal resistance
- max. 14.5 mm wide
- 3 different lengths for varied dissipation power
- takes less space than any other attachable heatsink
- simple assembly by pushing the heatsink onto the TO 220 housing
- the cooling fingers form spring clamps (1+2), which pushes the TO 220 and its mounting flange onto the heatsink (3)
- optimum heat transfer due to the constant pressure on the entire contact surface of the TO 220 cases
- effective heat emission with horizontal and vertical mounting
- * = touch in edge of transistor

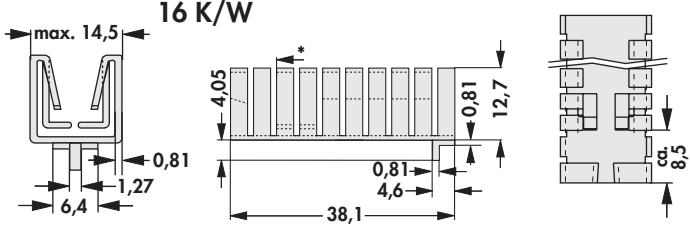
<p>art. no.</p>			<p>26 K/W</p> 	
<p>FK 242 SA 220 O</p>	<p>without soldering lug</p>			
<p>art. no.</p>			<p>21 K/W</p> 	
<p>FK 237 SA 220 O</p>	<p>without soldering lug</p>			
<p>art. no.</p>			<p>16 K/W</p> 	
<p>FK 240 SA 220 O</p>	<p>without soldering lug</p>			
<p>material:</p>	<p>aluminium</p>			
<p>surface:</p>	<p>black anodised, solder pins tin plated</p>			

Attachable heatsinks

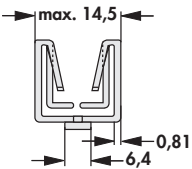
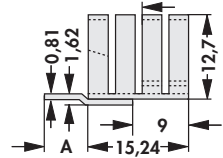
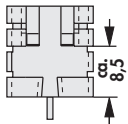
art. no.			26 K/W
FK 242 SA 220 H	with tinned soldering lug for direct soldering onto circuit board, for horizontal installation		
art. no.			21 K/W
FK 237 SA 220 H	with tinned soldering lug for direct soldering onto circuit board, for horizontal installation		
art. no.			16 K/W
FK 240 SA 220 H	with tinned soldering lug for direct soldering onto circuit board, for horizontal installation		
material:	aluminium		
surface:	black anodised, solder pins tin plated		

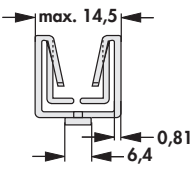
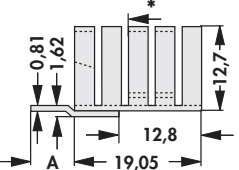
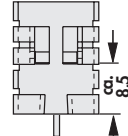
– with tinned soldering lug for direct soldering onto circuit board, for vertical installation

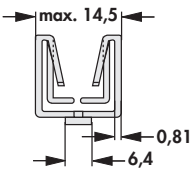
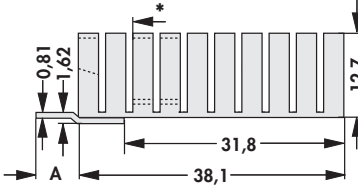
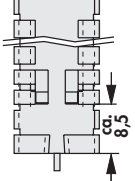
					
art. no.	A [mm]	R _{th} [K/W]	art. no.	A [mm]	R _{th} [K/W]
FK 242 SA 220 V	6.35	26	FK 242 SA 220 VL	9.53	26
					
art. no.	A [mm]	R _{th} [K/W]	art. no.	A [mm]	R _{th} [K/W]
FK 237 SA 220 V	6.35	21	FK 237 SA 220 VL	9.53	21
					
art. no.	A [mm]	R _{th} [K/W]	art. no.	A [mm]	R _{th} [K/W]
FK 240 SA 220 V	6.35	16	FK 240 SA 220 VL	9.53	16
material:	aluminium				
surface:	black anodised, solder pins tin plated				

Heatsinks for D PAK
Heatsinks for transistors
Kapton insulator washers
Vibration dampers

→ C 21
→ C 4 – 9
→ E 16
→ E 41



Vibration dampers
U-shaped heatsink
Aluminium oxide wafers
Technical introduction

→ E 41
→ A 123 – 124
→ E 17 – 18
→ A 2 – 8

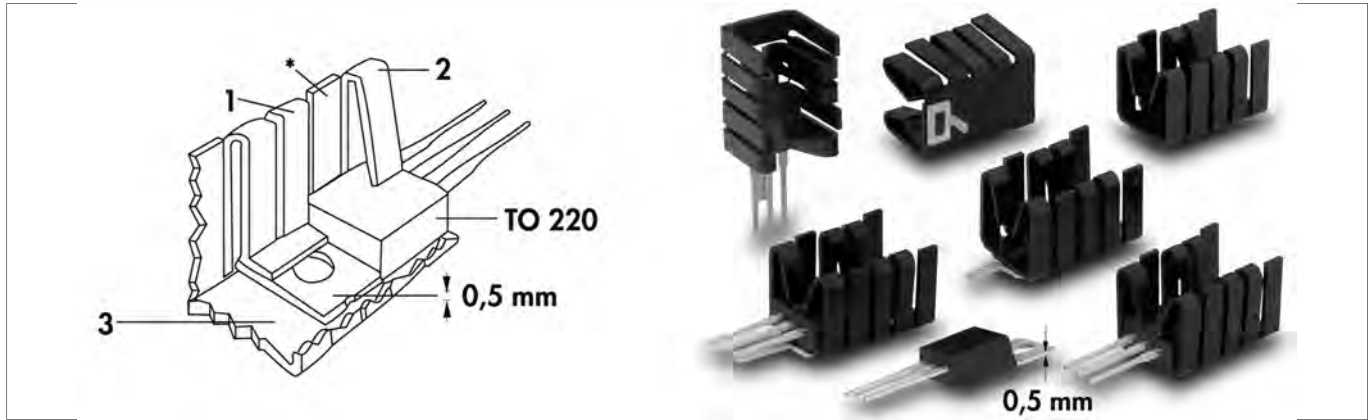
Attachable heatsinks for TO 220 with a bottom plate thickness of 0.5 mm



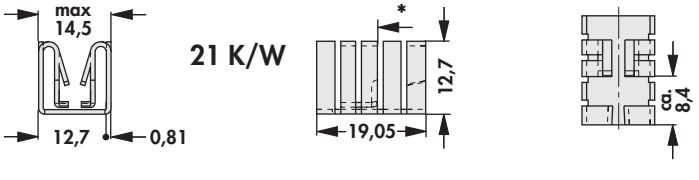
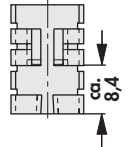

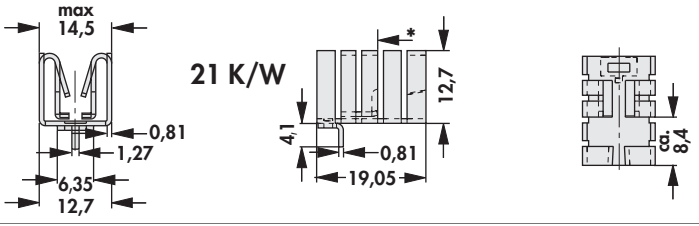
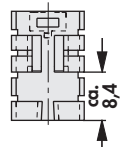

- narrow version with better thermal resistance
- max. 14.5 mm wide
- takes less space than any other attachable heatsink
- simple assembly by pushing the heatsink onto the TO 220 housing
- the cooling fingers form spring clamps (1+2), which pushes the TO 220 and it's mounting flange onto the heatsink (3)
- optimum heat transfer due the constant pressure on the entire contact surface of the TO 220 cases
- effective heat emmission with horizontal and vertical mounting
- * = touch in edge of transistor

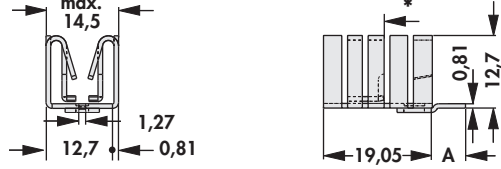
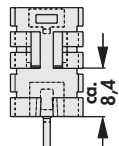
art. no.			21 K/W	
FK 252 SA 220 O	without soldering lug			
art. no.			21 K/W	
FK 252 SA 220 H	with tinned soldering lug for direct soldering onto circuit board, for horizontal installation			
material:	aluminium			
surface:	black anodised			



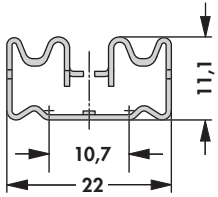
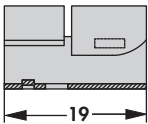
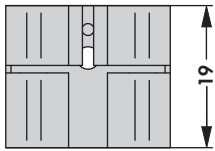

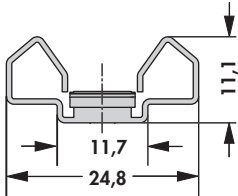
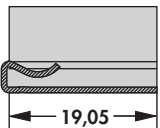
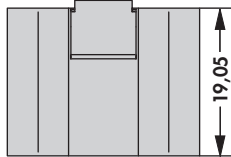

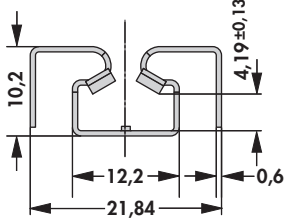
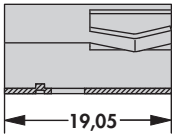
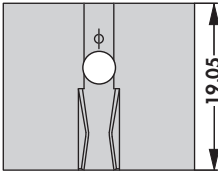
- with tinned soldering lug for direct soldering onto circuit board, for vertical installation

					
art. no.	A [mm]	R _{th} [K/W]	art. no.	A [mm]	R _{th} [K/W]
FK 252 SA 220 V	6.35	21	FK 252 SA 220 VL	9.53	21
material:	aluminium				
surface:	black anodised				

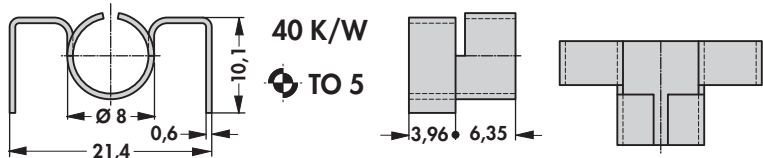

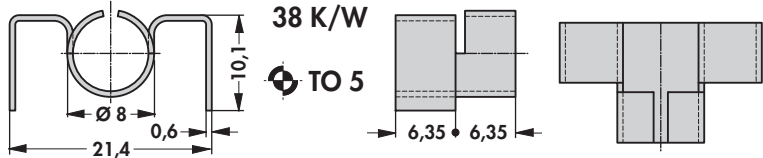

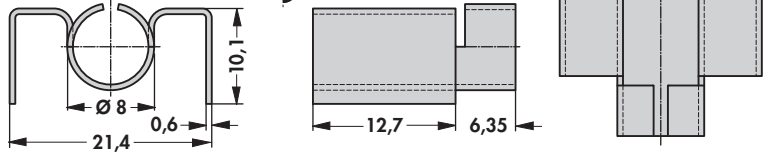

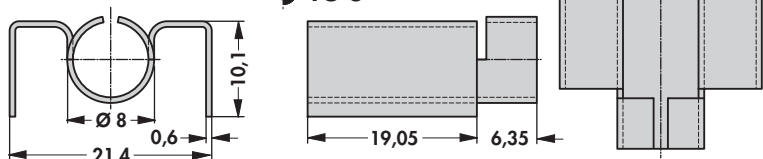
Attachable heatsinks

			
<p>art. no. FK 253</p>	<p>R_{th} [K/W] 23.7</p>	<p>⌀ TO 220</p>	
			
<p>art. no. FK 255</p>	<p>R_{th} [K/W] 16.8</p>	<p>⌀ TO 220</p>	
			
<p>art. no. FK 257</p>	<p>R_{th} [K/W] 21.2</p>	<p>⌀ TO 220</p>	
<p>material: surface:</p>	<p>aluminium black anodised</p>		

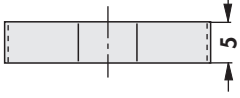
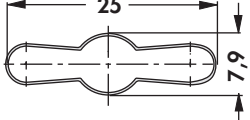

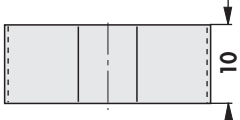
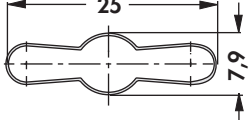

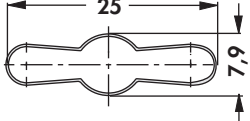

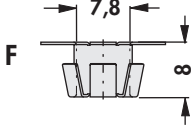
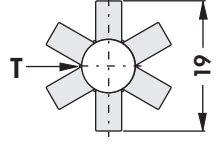

Small heatsinks

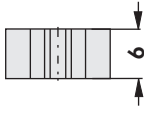
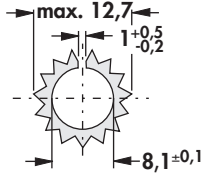
<p>art. no.</p> <p>KK 1 3,96</p>		
<p>art. no.</p> <p>KK 1 6,35</p>		
<p>art. no.</p> <p>KK 1 12,7</p>		
<p>art. no.</p> <p>KK 1 19,05</p>		
<p>material: aluminium</p> <p>surface: black anodised</p>		

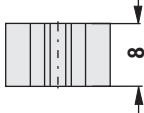
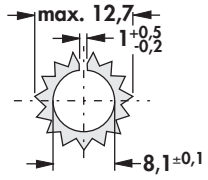
Small heatsinks

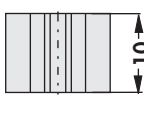
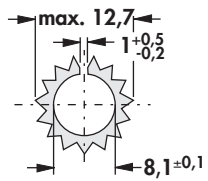
<p>art. no.</p> <p>KF 5/5</p>			<p>57 K/W</p> <p>TO 5</p>	
<p>art. no.</p> <p>KF 5/10</p>			<p>46 K/W</p> <p>TO 5</p>	
<p>art. no.</p> <p>KF 5/15</p>			<p>40 K/W</p> <p>TO 5</p>	
<p>material:</p>		<p>brass</p>		
<p>surface:</p>		<p>blackened</p>		
<p>art. no.</p> <p>KK 562 GS</p>			<p>60 K/W</p> <p>TO 5</p>	
<p>KK 562 GS</p>		<p>T = gap; F = spring loaded</p>		
<p>material:</p>		<p>special bronze CuZn 15</p>		
<p>material thickness:</p>		<p>0.3 mm</p>		
<p>surface:</p>		<p>blackened</p>		

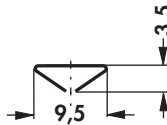
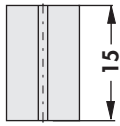
Small heatsinks

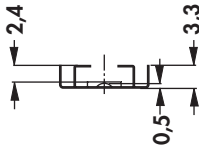
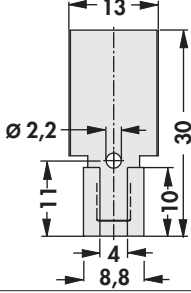
A	art. no.			63 K/W TO 5	
	SKK 56				
B	art. no.			55 K/W TO 5	
	SKK 58				
C	art. no.			44 K/W TO 5	
	SKK 510				
material:		aluminium			
surface:		etched (other surfaces on request)			
D	art. no.			80 K/W TO 126 SOT 32 SOT 82	
	KK 92				
E	art. no.			60 K/W TO 126 SOT 32 SOT 82	
	KK 32				
material:		special bronze CuZn 6			
surface:		blackened			

Heatsinks for D PAK and others

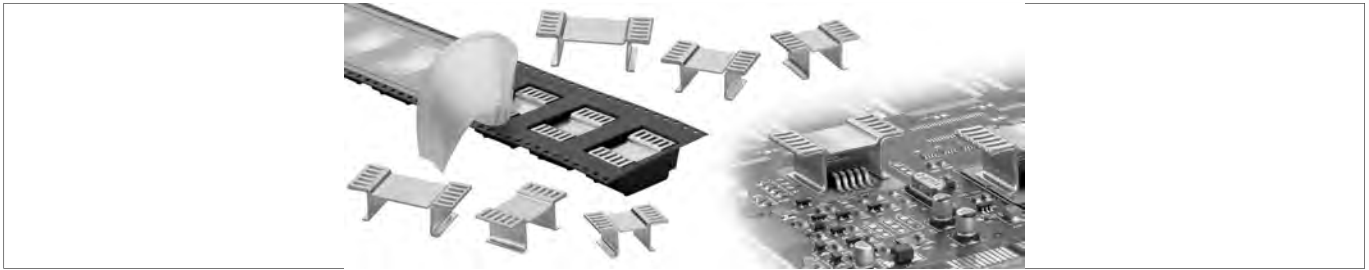

- copper heatsinks with excellent heat conductivity
- direct mounting on printed circuit through solderable surface
- especially suitable for SMD components of type D PAK (TO 252), D² PAK (TO 263), D³ PAK (TO 268), SOT 669 LF PAK, SO IC-8 FL MP, Power SO-8, Power SO-10, Power SO-20, Power SO-36, SO-14, SO-16, SOT 223 etc
- available standard packing: bulk parts or reel
- special packing like magazine, tray etc. on request; - special versions according to customers specifications
- **tape width:** 44 mm, **reel diameter:** 330 mm, **quantity:** FK 244 08 = 450, FK 244 13 = 200

art. no.			31,5 K/W
FK 244 08 D PAK ... weight: 2g			
art. no.			25 K/W
FK 244 13 D PAK ... weight: 3.3g			
art. no.			29,3 K/W
FK 244 08 D2 PAK ... weight: 2.2g			
art. no.			22,8 K/W
FK 244 13 D2 PAK ... weight: 3.6g			
art. no.			26 K/W
FK 244 08 D3 PAK ... weight: 2.5g			
art. no.			19,5 K/W
FK 244 13 D3 PAK ... weight: 3.9g			
please indicate:	... packing (optional) TR = tape and reel		
surface:	solderable surface		
material:	copper (Cu)		
material thickness:	0.6 mm		

Heatsinks for D PAK and others

- **tape width:** 24 mm, **reel diameter:** 330 mm, **quantity:** FK 250 06 = 450, FK 250 08 = 450, FK 250 10 = 350
- **tape width:** 24 mm, **reel diameter:** 330 mm, **quantity:** FK 251 06 = 450, FK 251 08 = 350, FK 251 10 = 250

art. no.			37 K/W	
FK 250 06 LF PAK ... weight: 1g				
art. no.			34,8 K/W	
FK 250 08 LF PAK ... weight: 1.1g				
art. no.			28,8 K/W	
FK 250 10 LF PAK ... weight: 1.2g				
art. no.			32 K/W	
FK 251 06 LF PAK ... weight: 1.3g				
art. no.			29,8 K/W	
FK 251 08 LF PAK ... weight: 1.4g				
art. no.			24 K/W	
FK 251 10 LF PAK ... weight: 1.5g				
please indicate:	... packing (optional) TR = tape and reel			
surface:	solderable surface			
material:	copper (Cu)			
material thickness:	0.6 mm			

art. no.			11 K/W	
FK 256				
surface:	solderable surface			
material:	aluminium			
material thickness:	0.6 mm			



Segment cooling aggregates

- modular assembly consisting of different circle- and length segments
- electrical and thermal insulation of the single cooling segment sections
- standard drilling patterns TO 3 and pressfit
- segment profile also sold by the meter
- other fan types and fan voltages upon request

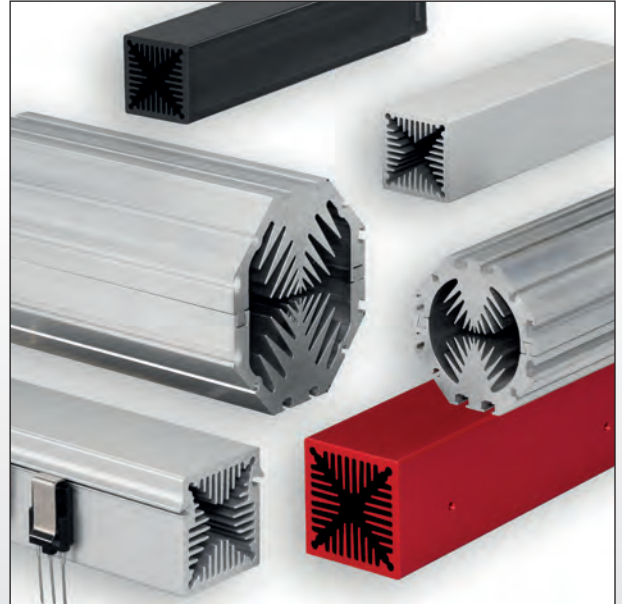

Miniature cooling aggregates

- compact construction for dissipating high power losses on smallest installation space
- heatsink geometries and fixed length optimal adjusted to the fan being used
- homogeneous heat dissipation
- mounting of the semi-conductor by means of sliding nut chanel or specific snap-to-retaining springs for transistors



Hollow fin cooling aggregates

- flow-optimized hollow fin geometry
- precise milled flat semiconductor mounting surface, single- and double-sided
- laminar airflow and noise reduction by means of harmonized chamber systems
- additional treatments, modifications and designs according to customers specifications



High performance heatsinks

- exclusive for forced convection
- for radial- and tangential fans
- flow-optimized design, best heat dissipation by means of especially thick bottom plates
- precise milled flat semiconductor mounting surfaces
- mechanical treatments, special designs and surface coating for your application

Order example (see drawing on the right)

Semiconductor cooling package, consisting of 4 heatsinks LA 1 - 2 A (segment C), 1 heatsink LA 1 - 8 A (segment D), 8 heatsinks LA 1 - 1 A (segment E) and 2 heatsinks LA 1 - 4 A (segment F).
Total dissipation 1280 W.

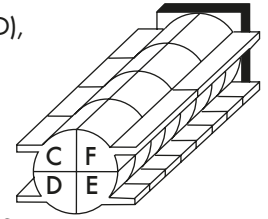

How to tick off?

1. Tick on the left hand side the circles corresponding to an eight element long package, and also at the end of each row of the segments C, D, E and F to define the length.
2. For segment C: 4 marks for four double length elements, insulated from each other. This indicates 4 units LA 1 - 2.
3. For segment D: 1 mark for one single length of heatsink, 290.5 mm long. This indicates 1 unit LA 1 - 8.
4. For segment E: 8 marks for 8 elements of the standard length (35 mm) each insulated from the other. This indicates 8 units LA 1 - 1.
5. For segment F: 2 marks for each two heatsinks of 144.5 mm length, each insulated from the other. This indicates 2 units LA 1 - 4.
6. For each segment the profile types, either A or B, must be indicated for aggregate LA 1.
7. In the rectangle corresponding to the heatsink elements, the pin layouts for the transistor should also be indicated.
8. In the order form please indicate whether the cooling-aggregate is to be supplied with a fan and whether this is equipped with a protection-grid, or if it is to be supplied without a fan.

Upon request, it is possible to supply fans for special voltages and higher temperatures.

LA 1 **LA 2**

date: _____

pieces p. order: _____

company: _____

name/dept.: _____

town: _____

street: _____

signature: _____

with fan 230 Volt Volt
 protection grid voltage: ~ =
 without fan ~ =

length units: mm	segment:			
	C	D	E	F
35.0	<input checked="" type="checkbox"/> <input type="checkbox"/> <input type="checkbox"/> Typ. A <input type="checkbox"/> B <input type="checkbox"/> TO-3 holder <input type="checkbox"/> TO-3 hole <input type="checkbox"/> pressfit hole	<input checked="" type="checkbox"/> <input type="checkbox"/> <input type="checkbox"/> Typ. A <input type="checkbox"/> B <input type="checkbox"/> TO-3 holder <input type="checkbox"/> TO-3 hole <input type="checkbox"/> pressfit hole	<input checked="" type="checkbox"/> <input type="checkbox"/> <input type="checkbox"/> Typ. A <input type="checkbox"/> B <input type="checkbox"/> TO-3 holder <input type="checkbox"/> TO-3 hole <input type="checkbox"/> pressfit hole	<input checked="" type="checkbox"/> <input type="checkbox"/> <input type="checkbox"/> Typ. A <input type="checkbox"/> B <input type="checkbox"/> TO-3 holder <input type="checkbox"/> TO-3 hole <input type="checkbox"/> pressfit hole
71.5	<input type="checkbox"/> <input type="checkbox"/> <input type="checkbox"/> Typ. A <input type="checkbox"/> B <input type="checkbox"/> TO-3 holder <input type="checkbox"/> TO-3 hole <input type="checkbox"/> pressfit hole	<input type="checkbox"/> <input type="checkbox"/> <input type="checkbox"/> Typ. A <input type="checkbox"/> B <input type="checkbox"/> TO-3 holder <input type="checkbox"/> TO-3 hole <input type="checkbox"/> pressfit hole	<input checked="" type="checkbox"/> <input type="checkbox"/> <input type="checkbox"/> Typ. A <input type="checkbox"/> B <input type="checkbox"/> TO-3 holder <input type="checkbox"/> TO-3 hole <input type="checkbox"/> pressfit hole	<input type="checkbox"/> <input type="checkbox"/> <input type="checkbox"/> Typ. A <input type="checkbox"/> B <input type="checkbox"/> TO-3 holder <input type="checkbox"/> TO-3 hole <input type="checkbox"/> pressfit hole
108.0	<input type="checkbox"/> <input type="checkbox"/> <input type="checkbox"/> Typ. A <input type="checkbox"/> B <input type="checkbox"/> TO-3 holder <input type="checkbox"/> TO-3 hole <input type="checkbox"/> pressfit hole	<input type="checkbox"/> <input type="checkbox"/> <input type="checkbox"/> Typ. A <input type="checkbox"/> B <input type="checkbox"/> TO-3 Fassung <input type="checkbox"/> TO-3 Lochung <input type="checkbox"/> Preßfit-Bohrgr.	<input checked="" type="checkbox"/> <input type="checkbox"/> <input type="checkbox"/> Typ. A <input type="checkbox"/> B <input type="checkbox"/> TO-3 holder <input type="checkbox"/> TO-3 hole <input type="checkbox"/> pressfit hole	<input type="checkbox"/> <input type="checkbox"/> <input type="checkbox"/> Typ. A <input type="checkbox"/> B <input type="checkbox"/> TO-3 holder <input type="checkbox"/> TO-3 hole <input type="checkbox"/> pressfit hole
144.5	<input type="checkbox"/> <input type="checkbox"/> <input type="checkbox"/> Typ. A <input type="checkbox"/> B <input type="checkbox"/> TO-3 holder <input type="checkbox"/> TO-3 hole <input type="checkbox"/> pressfit hole	<input type="checkbox"/> <input type="checkbox"/> <input type="checkbox"/> Typ. A <input type="checkbox"/> B <input type="checkbox"/> TO-3 holder <input type="checkbox"/> TO-3 hole <input type="checkbox"/> pressfit hole	<input checked="" type="checkbox"/> <input type="checkbox"/> <input type="checkbox"/> Typ. A <input type="checkbox"/> B <input type="checkbox"/> TO-3 holder <input type="checkbox"/> TO-3 hole <input type="checkbox"/> pressfit hole	<input checked="" type="checkbox"/> <input type="checkbox"/> <input type="checkbox"/> Typ. A <input type="checkbox"/> B <input type="checkbox"/> TO-3 holder <input type="checkbox"/> TO-3 hole <input type="checkbox"/> pressfit hole
181.0	<input type="checkbox"/> <input type="checkbox"/> <input type="checkbox"/> Typ. A <input type="checkbox"/> B <input type="checkbox"/> TO-3 holder <input type="checkbox"/> TO-3 hole <input type="checkbox"/> pressfit hole	<input type="checkbox"/> <input type="checkbox"/> <input type="checkbox"/> Typ. A <input type="checkbox"/> B <input type="checkbox"/> TO-3 holder <input type="checkbox"/> TO-3 hole <input type="checkbox"/> pressfit hole	<input checked="" type="checkbox"/> <input type="checkbox"/> <input type="checkbox"/> Typ. A <input type="checkbox"/> B <input type="checkbox"/> TO-3 holder <input type="checkbox"/> TO-3 hole <input type="checkbox"/> pressfit hole	<input type="checkbox"/> <input type="checkbox"/> <input type="checkbox"/> Typ. A <input type="checkbox"/> B <input type="checkbox"/> TO-3 holder <input type="checkbox"/> TO-3 hole <input type="checkbox"/> pressfit hole
217.5	<input type="checkbox"/> <input type="checkbox"/> <input type="checkbox"/> Typ. A <input type="checkbox"/> B <input type="checkbox"/> TO-3 holder <input type="checkbox"/> TO-3 hole <input type="checkbox"/> pressfit hole	<input type="checkbox"/> <input type="checkbox"/> <input type="checkbox"/> Typ. A <input type="checkbox"/> B <input type="checkbox"/> TO-3 holder <input type="checkbox"/> TO-3 hole <input type="checkbox"/> pressfit hole	<input checked="" type="checkbox"/> <input type="checkbox"/> <input type="checkbox"/> Typ. A <input type="checkbox"/> B <input type="checkbox"/> TO-3 holder <input type="checkbox"/> TO-3 hole <input type="checkbox"/> pressfit hole	<input type="checkbox"/> <input type="checkbox"/> <input type="checkbox"/> Typ. A <input type="checkbox"/> B <input type="checkbox"/> TO-3 holder <input type="checkbox"/> TO-3 hole <input type="checkbox"/> pressfit hole
254.0	<input type="checkbox"/> <input type="checkbox"/> <input type="checkbox"/> Typ. A <input type="checkbox"/> B <input type="checkbox"/> TO-3 holder <input type="checkbox"/> TO-3 hole <input type="checkbox"/> pressfit hole	<input type="checkbox"/> <input type="checkbox"/> <input type="checkbox"/> Typ. A <input type="checkbox"/> B <input type="checkbox"/> TO-3 holder <input type="checkbox"/> TO-3 hole <input type="checkbox"/> pressfit hole	<input checked="" type="checkbox"/> <input type="checkbox"/> <input type="checkbox"/> Typ. A <input type="checkbox"/> B <input type="checkbox"/> TO-3 holder <input type="checkbox"/> TO-3 hole <input type="checkbox"/> pressfit hole	<input type="checkbox"/> <input type="checkbox"/> <input type="checkbox"/> Typ. A <input type="checkbox"/> B <input type="checkbox"/> TO-3 holder <input type="checkbox"/> TO-3 hole <input type="checkbox"/> pressfit hole
290.5	<input checked="" type="checkbox"/> <input type="checkbox"/> <input type="checkbox"/> Typ. A <input type="checkbox"/> B <input type="checkbox"/> TO-3 holder <input type="checkbox"/> TO-3 hole <input type="checkbox"/> pressfit hole	<input type="checkbox"/> <input type="checkbox"/> <input type="checkbox"/> Typ. A <input type="checkbox"/> B <input type="checkbox"/> TO-3 holder <input type="checkbox"/> TO-3 hole <input type="checkbox"/> pressfit hole	<input checked="" type="checkbox"/> <input type="checkbox"/> <input type="checkbox"/> Typ. A <input type="checkbox"/> B <input type="checkbox"/> TO-3 holder <input type="checkbox"/> TO-3 hole <input type="checkbox"/> pressfit hole	<input checked="" type="checkbox"/> <input type="checkbox"/> <input type="checkbox"/> Typ. A <input type="checkbox"/> B <input type="checkbox"/> TO-3 holder <input type="checkbox"/> TO-3 hole <input type="checkbox"/> pressfit hole
327.0	<input type="checkbox"/> <input type="checkbox"/> <input type="checkbox"/> Typ. A <input type="checkbox"/> B <input type="checkbox"/> TO-3 holder <input type="checkbox"/> TO-3 hole <input type="checkbox"/> pressfit hole	<input type="checkbox"/> <input type="checkbox"/> <input type="checkbox"/> Typ. A <input type="checkbox"/> B <input type="checkbox"/> TO-3 holder <input type="checkbox"/> TO-3 hole <input type="checkbox"/> pressfit hole	<input checked="" type="checkbox"/> <input type="checkbox"/> <input type="checkbox"/> Typ. A <input type="checkbox"/> B <input type="checkbox"/> TO-3 holder <input type="checkbox"/> TO-3 hole <input type="checkbox"/> pressfit hole	<input type="checkbox"/> <input type="checkbox"/> <input type="checkbox"/> Typ. A <input type="checkbox"/> B <input type="checkbox"/> TO-3 holder <input type="checkbox"/> TO-3 hole <input type="checkbox"/> pressfit hole
363.5	<input type="checkbox"/> <input type="checkbox"/> <input type="checkbox"/> Typ. A <input type="checkbox"/> B <input type="checkbox"/> TO-3 holder <input type="checkbox"/> TO-3 hole <input type="checkbox"/> pressfit hole	<input type="checkbox"/> <input type="checkbox"/> <input type="checkbox"/> Typ. A <input type="checkbox"/> B <input type="checkbox"/> TO-3 holder <input type="checkbox"/> TO-3 hole <input type="checkbox"/> pressfit hole	<input type="checkbox"/> <input type="checkbox"/> <input type="checkbox"/> Typ. A <input type="checkbox"/> B <input type="checkbox"/> TO-3 holder <input type="checkbox"/> TO-3 hole <input type="checkbox"/> pressfit hole	<input type="checkbox"/> <input type="checkbox"/> <input type="checkbox"/> Typ. A <input type="checkbox"/> B <input type="checkbox"/> TO-3 holder <input type="checkbox"/> TO-3 hole <input type="checkbox"/> pressfit hole

C **D** **E** **F**

Please check off here total length of the cooling aggregate.

cable connection

The segment-line C-D-E-F is shown against air-escape orifice, thus on the other side of the axial fan.
From this view also tick off cable terminal with axial fan.

A

B

date: _____

pieces p. order: _____

company: _____

name/dept.: _____

town: _____

street: _____

signature: _____

D

- with fan 230 Volt Volt
 protection grid voltage:
 without fan ~ =

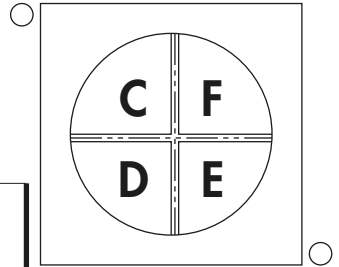

cable connection

length units:
mm

segment:	segment:	segment:	segment:
35.0 1	<input type="radio"/> Typ. A ○ B <input type="radio"/> TO-3 holder <input type="radio"/> TO-3 hole <input type="radio"/> pressfit hole	<input type="radio"/> Typ. A ○ B <input type="radio"/> TO-3 holder <input type="radio"/> TO-3 hole <input type="radio"/> pressfit hole	<input type="radio"/> Typ. A ○ B <input type="radio"/> TO-3 holder <input type="radio"/> TO-3 hole <input type="radio"/> pressfit hole
71.5 2	<input type="radio"/> Typ. A ○ B <input type="radio"/> TO-3 holder <input type="radio"/> TO-3 hole <input type="radio"/> pressfit hole	<input type="radio"/> Typ. A ○ B <input type="radio"/> TO-3 holder <input type="radio"/> TO-3 hole <input type="radio"/> pressfit hole	<input type="radio"/> Typ. A ○ B <input type="radio"/> TO-3 holder <input type="radio"/> TO-3 hole <input type="radio"/> pressfit hole
108.0 3	<input type="radio"/> Typ. A ○ B <input type="radio"/> TO-3 holder <input type="radio"/> TO-3 hole <input type="radio"/> pressfit hole	<input type="radio"/> Typ. A ○ B <input type="radio"/> TO-3 Fassung <input type="radio"/> TO-3 Lochung <input type="radio"/> Preßfit-Bohrg.	<input type="radio"/> Typ. A ○ B <input type="radio"/> TO-3 holder <input type="radio"/> TO-3 hole <input type="radio"/> pressfit hole
144.5 4	<input type="radio"/> Typ. A ○ B <input type="radio"/> TO-3 holder <input type="radio"/> TO-3 hole <input type="radio"/> pressfit hole	<input type="radio"/> Typ. A ○ B <input type="radio"/> TO-3 holder <input type="radio"/> TO-3 hole <input type="radio"/> pressfit hole	<input type="radio"/> Typ. A ○ B <input type="radio"/> TO-3 holder <input type="radio"/> TO-3 hole <input type="radio"/> pressfit hole
181.0 5	<input type="radio"/> Typ. A ○ B <input type="radio"/> TO-3 holder <input type="radio"/> TO-3 hole <input type="radio"/> pressfit hole	<input type="radio"/> Typ. A ○ B <input type="radio"/> TO-3 holder <input type="radio"/> TO-3 hole <input type="radio"/> pressfit hole	<input type="radio"/> Typ. A ○ B <input type="radio"/> TO-3 holder <input type="radio"/> TO-3 hole <input type="radio"/> pressfit hole
217.5 6	<input type="radio"/> Typ. A ○ B <input type="radio"/> TO-3 holder <input type="radio"/> TO-3 hole <input type="radio"/> pressfit hole	<input type="radio"/> Typ. A ○ B <input type="radio"/> TO-3 holder <input type="radio"/> TO-3 hole <input type="radio"/> pressfit hole	<input type="radio"/> Typ. A ○ B <input type="radio"/> TO-3 holder <input type="radio"/> TO-3 hole <input type="radio"/> pressfit hole
254.0 7	<input type="radio"/> Typ. A ○ B <input type="radio"/> TO-3 holder <input type="radio"/> TO-3 hole <input type="radio"/> pressfit hole	<input type="radio"/> Typ. A ○ B <input type="radio"/> TO-3 holder <input type="radio"/> TO-3 hole <input type="radio"/> pressfit hole	<input type="radio"/> Typ. A ○ B <input type="radio"/> TO-3 holder <input type="radio"/> TO-3 hole <input type="radio"/> pressfit hole
290.5 8	<input type="radio"/> Typ. A ○ B <input type="radio"/> TO-3 holder <input type="radio"/> TO-3 hole <input type="radio"/> pressfit hole	<input type="radio"/> Typ. A ○ B <input type="radio"/> TO-3 holder <input type="radio"/> TO-3 hole <input type="radio"/> pressfit hole	<input type="radio"/> Typ. A ○ B <input type="radio"/> TO-3 holder <input type="radio"/> TO-3 hole <input type="radio"/> pressfit hole
327.0 9	<input type="radio"/> Typ. A ○ B <input type="radio"/> TO-3 holder <input type="radio"/> TO-3 hole <input type="radio"/> pressfit hole	<input type="radio"/> Typ. A ○ B <input type="radio"/> TO-3 holder <input type="radio"/> TO-3 hole <input type="radio"/> pressfit hole	<input type="radio"/> Typ. A ○ B <input type="radio"/> TO-3 holder <input type="radio"/> TO-3 hole <input type="radio"/> pressfit hole
363.5 10	<input type="radio"/> Typ. A ○ B <input type="radio"/> TO-3 holder <input type="radio"/> TO-3 hole <input type="radio"/> pressfit hole	<input type="radio"/> Typ. A ○ B <input type="radio"/> TO-3 holder <input type="radio"/> TO-3 hole <input type="radio"/> pressfit hole	<input type="radio"/> Typ. A ○ B <input type="radio"/> TO-3 holder <input type="radio"/> TO-3 hole <input type="radio"/> pressfit hole

The segment-line C-D-E-F is shown against air-escape orifice, thus on the other side of the axial fan.
From this view also tick off cable terminal with axial fan.

H

I

K

L

M

Please check off here total length of the cooling aggregate.

N

D 3

POB 1590
Nottebohmstraße 28
Tel.: +49 (0) 23 51 / 4 35-0

D - 58465 Lüdenscheid
D - 58511 Lüdenscheid
Fax: +49 (0) 23 51 / 4 57 54

info@fischerelektronik.de
www.fischerelektronik.de
www.facebook.de/fischerelektronik

LA 1 LA 2

date: _____
 pieces p. order: _____
 company: _____
 name/dept.: _____
 town: _____
 street: _____
 signature: _____

<input type="radio"/> with fan	<input type="radio"/> 230 Volt	<input type="radio"/> Volt
<input type="radio"/> protection grid	voltage:	
<input type="radio"/> without fan	<input type="radio"/> ~ <input type="radio"/> =	

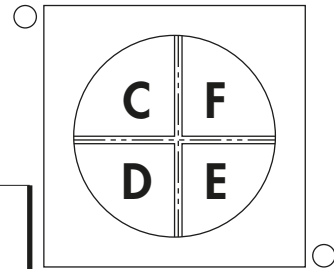

cable connection

length units: mm	segment: <input type="radio"/>	segment: <input type="radio"/>	segment: <input type="radio"/>	segment: <input type="radio"/>
35.0 1 <input type="radio"/>	<input type="radio"/> Typ. A <input type="radio"/> B <input type="radio"/> TO-3 holder <input type="radio"/> TO-3 hole <input type="radio"/> pressfit hole	<input type="radio"/> Typ. A <input type="radio"/> B <input type="radio"/> TO-3 holder <input type="radio"/> TO-3 hole <input type="radio"/> pressfit hole	<input type="radio"/> Typ. A <input type="radio"/> B <input type="radio"/> TO-3 holder <input type="radio"/> TO-3 hole <input type="radio"/> pressfit hole	<input type="radio"/> Typ. A <input type="radio"/> B <input type="radio"/> TO-3 holder <input type="radio"/> TO-3 hole <input type="radio"/> pressfit hole
71.5 2 <input type="radio"/>	<input type="radio"/> Typ. A <input type="radio"/> B <input type="radio"/> TO-3 holder <input type="radio"/> TO-3 hole <input type="radio"/> pressfit hole	<input type="radio"/> Typ. A <input type="radio"/> B <input type="radio"/> TO-3 holder <input type="radio"/> TO-3 hole <input type="radio"/> pressfit hole	<input type="radio"/> Typ. A <input type="radio"/> B <input type="radio"/> TO-3 holder <input type="radio"/> TO-3 hole <input type="radio"/> pressfit hole	<input type="radio"/> Typ. A <input type="radio"/> B <input type="radio"/> TO-3 holder <input type="radio"/> TO-3 hole <input type="radio"/> pressfit hole
108.0 3 <input type="radio"/>	<input type="radio"/> Typ. A <input type="radio"/> B <input type="radio"/> TO-3 holder <input type="radio"/> TO-3 hole <input type="radio"/> pressfit hole	<input type="radio"/> Typ. A <input type="radio"/> B <input type="radio"/> TO-3 Fassung <input type="radio"/> TO-3 Lochung <input type="radio"/> Preßfit-Bohrg.	<input type="radio"/> Typ. A <input type="radio"/> B <input type="radio"/> TO-3 holder <input type="radio"/> TO-3 hole <input type="radio"/> pressfit hole	<input type="radio"/> Typ. A <input type="radio"/> B <input type="radio"/> TO-3 holder <input type="radio"/> TO-3 hole <input type="radio"/> pressfit hole
144.5 4 <input type="radio"/>	<input type="radio"/> Typ. A <input type="radio"/> B <input type="radio"/> TO-3 holder <input type="radio"/> TO-3 hole <input type="radio"/> pressfit hole	<input type="radio"/> Typ. A <input type="radio"/> B <input type="radio"/> TO-3 holder <input type="radio"/> TO-3 hole <input type="radio"/> pressfit hole	<input type="radio"/> Typ. A <input type="radio"/> B <input type="radio"/> TO-3 holder <input type="radio"/> TO-3 hole <input type="radio"/> pressfit hole	<input type="radio"/> Typ. A <input type="radio"/> B <input type="radio"/> TO-3 holder <input type="radio"/> TO-3 hole <input type="radio"/> pressfit hole
181.0 5 <input type="radio"/>	<input type="radio"/> Typ. A <input type="radio"/> B <input type="radio"/> TO-3 holder <input type="radio"/> TO-3 hole <input type="radio"/> pressfit hole	<input type="radio"/> Typ. A <input type="radio"/> B <input type="radio"/> TO-3 holder <input type="radio"/> TO-3 hole <input type="radio"/> pressfit hole	<input type="radio"/> Typ. A <input type="radio"/> B <input type="radio"/> TO-3 holder <input type="radio"/> TO-3 hole <input type="radio"/> pressfit hole	<input type="radio"/> Typ. A <input type="radio"/> B <input type="radio"/> TO-3 holder <input type="radio"/> TO-3 hole <input type="radio"/> pressfit hole
217.5 6 <input type="radio"/>	<input type="radio"/> Typ. A <input type="radio"/> B <input type="radio"/> TO-3 holder <input type="radio"/> TO-3 hole <input type="radio"/> pressfit hole	<input type="radio"/> Typ. A <input type="radio"/> B <input type="radio"/> TO-3 holder <input type="radio"/> TO-3 hole <input type="radio"/> pressfit hole	<input type="radio"/> Typ. A <input type="radio"/> B <input type="radio"/> TO-3 holder <input type="radio"/> TO-3 hole <input type="radio"/> pressfit hole	<input type="radio"/> Typ. A <input type="radio"/> B <input type="radio"/> TO-3 holder <input type="radio"/> TO-3 hole <input type="radio"/> pressfit hole
254.0 7 <input type="radio"/>	<input type="radio"/> Typ. A <input type="radio"/> B <input type="radio"/> TO-3 holder <input type="radio"/> TO-3 hole <input type="radio"/> pressfit hole	<input type="radio"/> Typ. A <input type="radio"/> B <input type="radio"/> TO-3 holder <input type="radio"/> TO-3 hole <input type="radio"/> pressfit hole	<input type="radio"/> Typ. A <input type="radio"/> B <input type="radio"/> TO-3 holder <input type="radio"/> TO-3 hole <input type="radio"/> pressfit hole	<input type="radio"/> Typ. A <input type="radio"/> B <input type="radio"/> TO-3 holder <input type="radio"/> TO-3 hole <input type="radio"/> pressfit hole
290.5 8 <input type="radio"/>	<input type="radio"/> Typ. A <input type="radio"/> B <input type="radio"/> TO-3 holder <input type="radio"/> TO-3 hole <input type="radio"/> pressfit hole	<input type="radio"/> Typ. A <input type="radio"/> B <input type="radio"/> TO-3 holder <input type="radio"/> TO-3 hole <input type="radio"/> pressfit hole	<input type="radio"/> Typ. A <input type="radio"/> B <input type="radio"/> TO-3 holder <input type="radio"/> TO-3 hole <input type="radio"/> pressfit hole	<input type="radio"/> Typ. A <input type="radio"/> B <input type="radio"/> TO-3 holder <input type="radio"/> TO-3 hole <input type="radio"/> pressfit hole
327.0 9 <input type="radio"/>	<input type="radio"/> Typ. A <input type="radio"/> B <input type="radio"/> TO-3 holder <input type="radio"/> TO-3 hole <input type="radio"/> pressfit hole	<input type="radio"/> Typ. A <input type="radio"/> B <input type="radio"/> TO-3 holder <input type="radio"/> TO-3 hole <input type="radio"/> pressfit hole	<input type="radio"/> Typ. A <input type="radio"/> B <input type="radio"/> TO-3 holder <input type="radio"/> TO-3 hole <input type="radio"/> pressfit hole	<input type="radio"/> Typ. A <input type="radio"/> B <input type="radio"/> TO-3 holder <input type="radio"/> TO-3 hole <input type="radio"/> pressfit hole
363.5 10 <input type="radio"/>	<input type="radio"/> Typ. A <input type="radio"/> B <input type="radio"/> TO-3 holder <input type="radio"/> TO-3 hole <input type="radio"/> pressfit hole	<input type="radio"/> Typ. A <input type="radio"/> B <input type="radio"/> TO-3 holder <input type="radio"/> TO-3 hole <input type="radio"/> pressfit hole	<input type="radio"/> Typ. A <input type="radio"/> B <input type="radio"/> TO-3 holder <input type="radio"/> TO-3 hole <input type="radio"/> pressfit hole	<input type="radio"/> Typ. A <input type="radio"/> B <input type="radio"/> TO-3 holder <input type="radio"/> TO-3 hole <input type="radio"/> pressfit hole

The segment-line C-D-E-F is shown against air-escape orifice, thus on the other side of the axial fan. From this view also tick off cable terminal with axial fan.

Please check off here total length of the cooling aggregate.

Segment cooling aggregates

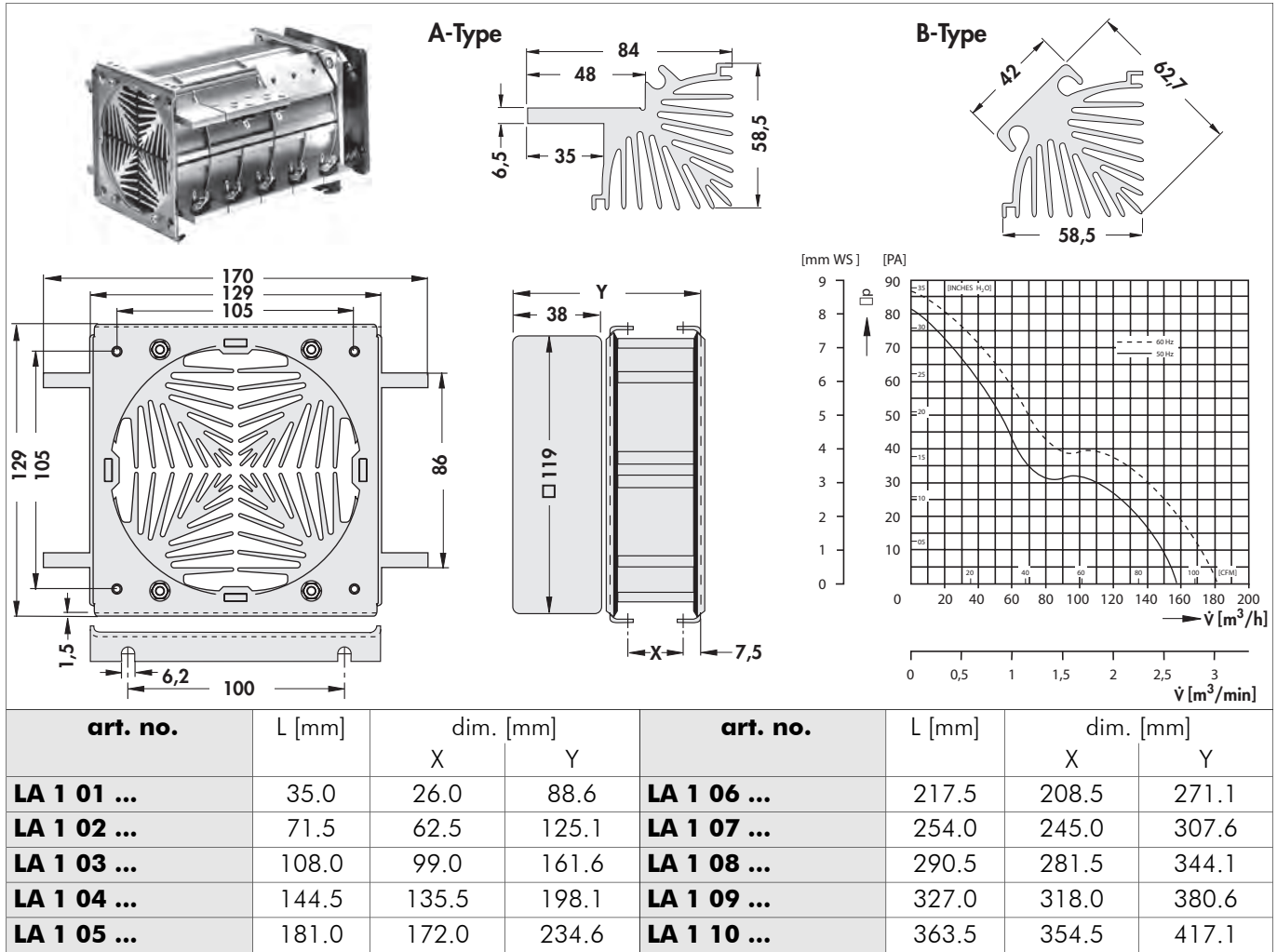

... for A-types: please add an "A", for B-types: please add a "B".

L: unit lengths of the segments incl. insulation; **X**: mounting distance; **Y**: length of the cooling aggregate incl. fan

24 V DC fan on request

In case of order please use order form.

segments also available in meter length:

art. no. for A-type: LA 1 1000 A; art. no. for B-type: LA 1 1000 B

Other fan types and fan voltages on request.

Technical data of the fans

	... 230
type	ebmpapst, ball bearing
dimensions	119x119x38 mm
tension	230 V AC
power inout	19 W
max. air volume	160 m ³ /h
temperature range	-40°C... +85°C
noise level	47 dB(A)
speed	2,650 min ⁻¹
weight	550 g
failure rate (L₁₀)	L ₁₀ < 37,500 h (40°C)

D 5

Miniature cooling aggregates
Protection grid for axial fans
Thermal conductive material
Heatsinks with hollow fin profile

→ D 9 - 11
→ D 36
→ E 2 - 29
→ D 30

Order example
Order form
Mounting parts for heatsinks
Technical introduction

→ D 2
→ D 3 - 4
→ E 49 - 50
→ A 2 - 8

Thermal resistance LA 1

The thermal resistance in the following diagrams is given on the base of a total dissipation of 40 Watt per heatsink of the „A“-type. When using „B“-types this value increases by 3 %.

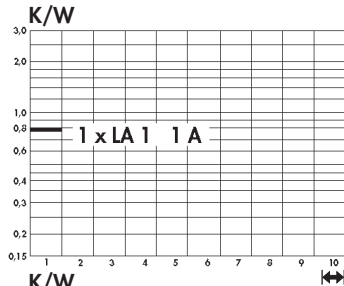

1. Cooling aggregate consisting of 4 heatsinks LA 1 - 1 A.
Total dissipation 160 W.

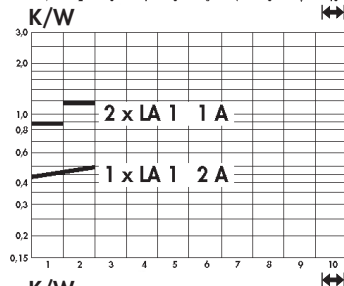

2. Cooling aggregate consisting of 4 heatsinks LA 1 - 1 A and 2 x 1 heatsink LA 1 - 2 A.
Total dissipation 320 W.

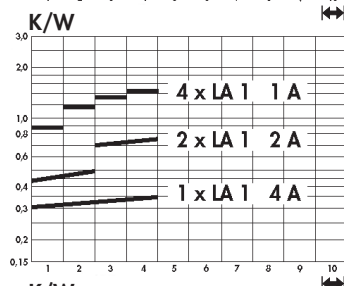

3. Cooling aggregate consisting of 4 heatsinks LA 1 - 1 A, 2 heatsinks LA 1 - 2 A and 2 x 1 heatsink LA 1 - 4 A. Total dissipation 640 W.

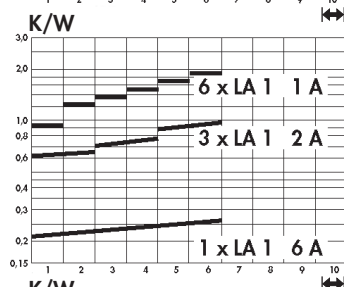

4. Cooling aggregate consisting of 6 heatsinks LA 1 - 1 A, 3 heatsinks LA 1 - 2 A and 2 x 1 heatsink LA 1 - 6 A. Total dissipation 960 W.

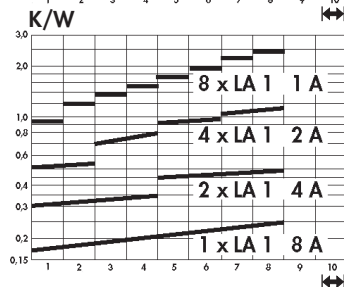

5. Cooling aggregate consisting of 8 heatsinks LA 1 - 1 A, 4 heatsinks LA 1 - 2 A, 2 heatsinks LA 1 - 4 A and 1 heatsink LA 1 - 8 A. Total dissipation 1280 W.

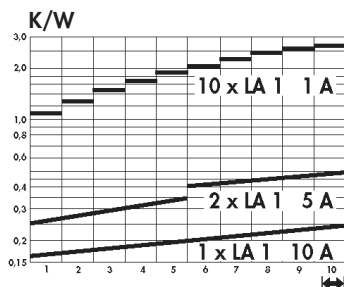

6. Cooling aggregate consisting of 10 heatsinks LA 1 - 1 A, 2 heatsinks LA 1 - 5 A, and 2 x 1 heatsink LA 1 - 10 A. Total dissipation 1600 W.

Miniature cooling aggregates
Protection grid for axial fans
Thermal conductive material
Heatsinks with hollow fin profile

→ D 9 - 11
→ D 36
→ E 2 - 29
→ D 30

Order example
Order form
Mounting parts for heatsinks
Technical introduction

→ D 2
→ D 3 - 4
→ E 49 - 50
→ A 2 - 8

D 6

Segment cooling aggregates

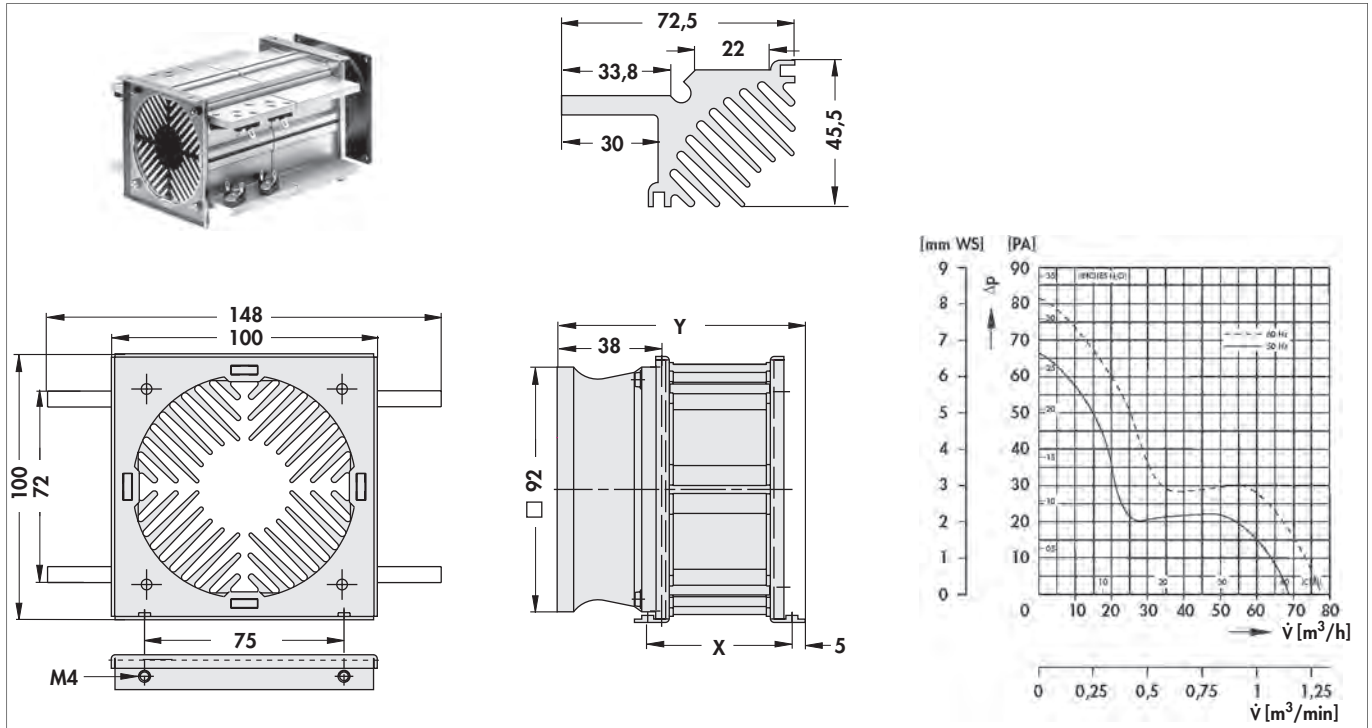

art. no.	L [mm]	dim. [mm]		art. no.	L [mm]	dim. [mm]	
		X	Y			X	Y
LA 2 01 ...	35.0	54.2	92.0	LA 2 06 ...	217.5	236.7	274.5
LA 2 02 ...	71.5	90.7	128.5	LA 2 07 ...	254.0	273.2	311.0
LA 2 03 ...	108.0	127.2	165.0	LA 2 08 ...	290.5	309.7	347.5
LA 2 04 ...	144.5	163.7	201.5	LA 2 09 ...	327.0	346.2	384.0
LA 2 05 ...	181.0	200.2	238.0	LA 2 10 ...	363.5	382.7	420.5

L: unit lengths of the segments incl. insulation; **X:** mounting distance; **Y:** length of the cooling aggregate incl. fan

24 V DC fan on request

In case of order please use order form.

segments also available in meter length: **art. no. for A-type: LA 1 1000 A; art. no. for B-type: LA 2 1000 B**

Other fan types and fan voltages on request.

Technical data of the fans

	... 230
type	ebmpapst, ball bearing
dimensions	92x92x38 mm
tension	230 V AC
power inout	12 W
max. air volume	75 m³/h
temperature range	-40°C... +75°C
noise level	37 dB(A)
speed	2,700 min ⁻¹
weight	420 g
failure rate (L₁₀)	L ₁₀ < 52,500 h (40°C)

D 7

Miniature cooling aggregates
Protection grid for axial fans
Thermal conductive material
Heatsinks with hollow fin profile

→ D 9 - 11
→ D 36
→ E 2 - 29
→ D 30

Order example
Order form
Mounting parts for heatsinks
Technical introduction

→ D 2
→ D 3 - 4
→ E 49 - 50
→ A 2 - 8

Thermal resistance LA 2

The thermal resistance in the following diagrams is given on the base of a total dissipation of 40 Watt per heatsink of the „A“-type.

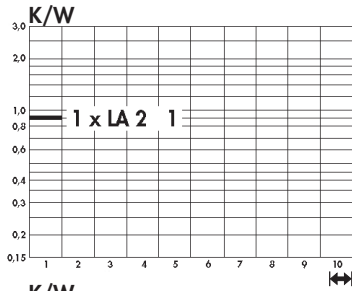

1. Cooling aggregate consisting of 4 heatsinks LA 2 - 1. Total dissipation 160 W maximal.

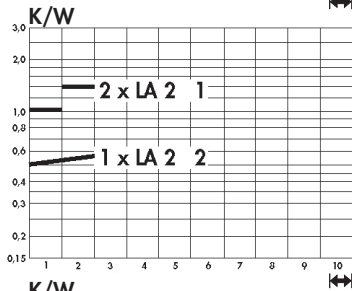

2. Cooling aggregate consisting of 4 heatsinks LA 2 - 1 and 2 x 1 heatsink LA 2 - 2. Total dissipation 320 W.

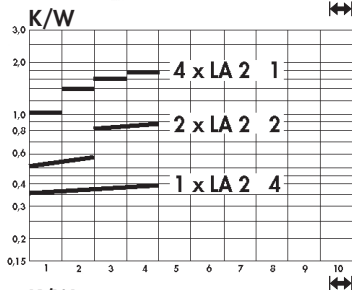

3. Cooling aggregate consisting of 4 heatsinks LA 2 - 1, 2 heatsinks LA 2 - 2 and 2 x 1 heatsink LA 2 - 4. Total dissipation 640 W.

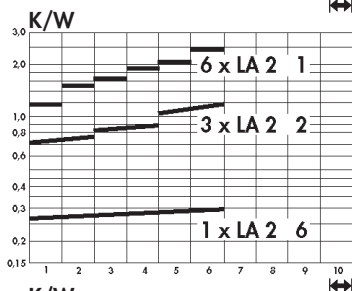

4. Cooling aggregate consisting of 6 heatsinks LA 2 - 1, 3 heatsinks LA 2 - 2 and 2 x 1 heatsink LA 2 - 6. Total dissipation 960 W.

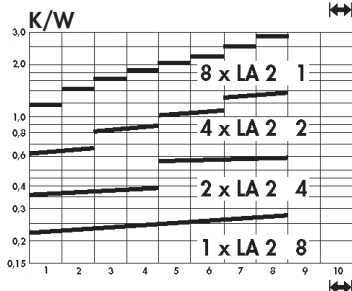

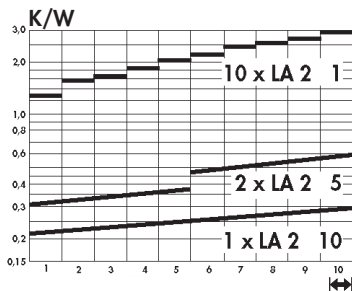

5. Cooling aggregate consisting of 8 heatsinks LA 2 - 1, 4 heatsinks LA 2 - 2, 2 heatsinks LA 2 - 4 and 1 heatsink LA 2 - 8. Total dissipation 1280 W.



6. Cooling aggregate consisting of 10 heatsinks LA 2 - 1, 2 heatsinks LA 2 - 5, and 2 x 1 heatsink LA 2 - 10. Total dissipation 1600 W.

Miniature cooling aggregates

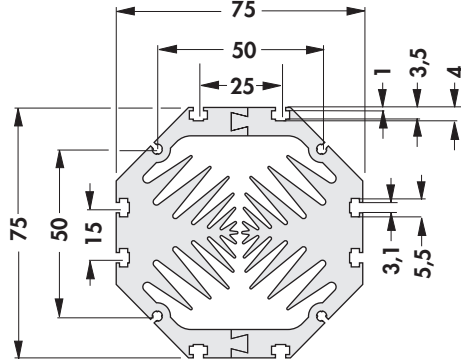
- made for dissipation of high power within a very small space
- approximate length is optimised to the fan motor
- slide-nut channels for M3 nuts for mounting the transistors and circuit boards
- other fan types and fan voltages on request

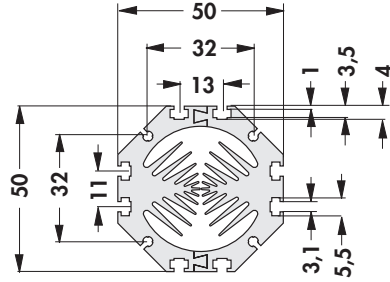
<p>art. no.</p>		<p>art. no.</p> <p>140 mm 0,3 K/W</p> 
<p>LAM 1</p> <p>art. no.</p>		<p>art. no.</p> <p>100 mm 0,73 K/W</p> 
<p>surface:</p>		<p>natural colour anodised</p>

Technical data of the fans

	LAM 1	LAM 2
type	ebmpapst 612 NHH-118	ebmpapst 412 F
dimensions	60x60x25 mm	40x40x10 mm
tension	12 V DC	12 V DC
power inout	2.9 W	0.7 W
max. air volume	56 m ³ /h	8 m ³ /h
temperature range	-20°C... +70°C	-20°C... +70°C
noise level	41 dB(A)	22.1 dB(A)
speed	6,800 min ⁻¹	5,400 min ⁻¹
weight	66 g	17 g
failure rate (L₁₀)	L ₁₀ < 60,000 h (40°C)	L ₁₀ < 45,000 h (20°C)

Miniature cooling aggregates

- compact design
- homogeneous heat dissipation
- mounting possible on any side
- powerful axial-fan motor
- other lengths, special designs and processing according to customer's requirements
- other surfaces treatment, fan types and fan voltages on request

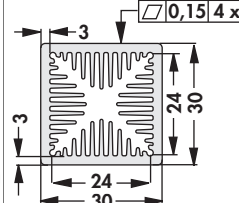
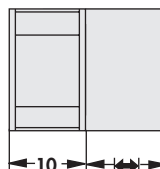
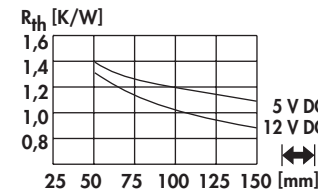
art. no.				
LAM 3 ...				
please indicate:	... $\left[\begin{array}{ c } \hline \text{---} \\ \hline \end{array} \right]$ 50 75 100 125 150 mm		... fan type 5 = 5 V DC 12 = 12 V DC	
surface:	natural colour anodised			

- with grooves for lock-in retaining spring for transistors THFU → A 119
- compact design
- homogeneous heat dissipation
- mounting possible on any side
- powerful axial-fan motor
- other lengths, special designs and processing according to customers requirements
- other surfaces treatment, fan types and fan voltages on request

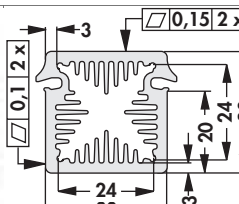
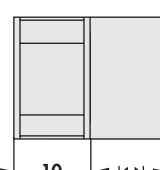
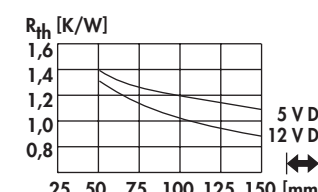
art. no.				
LAM 3 K ...				
please indicate:	... $\left[\begin{array}{ c } \hline \text{---} \\ \hline \end{array} \right]$ 50 75 100 125 150 mm		... fan type 5 = 5 V DC 12 = 12 V DC	
surface:	natural colour anodised			

Technical data of the fans

	... 5	... 12
type	Sepa, ball bearing	Sepa, ball bearing
dimensions	30x30x10 mm	30x30x10 mm
tension	5 V DC	12 V DC
max. air volume	6.8 m ³ /h	7.7 m ³ /h
cur. consumpt.	130 mA	70 mA
temperature range	-10°C... +70°C	-10°C... +70°C
noise level	21 dB(A)	23 dB(A)
speed	8,500 min ⁻¹	9,100 min ⁻¹
weight	8 g	8 g
failure rate (L₁₀)	L ₁₀ < 95,000 h (20°C) MTBF < 280,000 h (20°C)	L ₁₀ < 95,000 h (20°C) MTBF < 280,000 h (20°C)



Retaining springs for transistors
Special heatsink design
Hollow-fin cooling aggregates
High capacity cooling aggregat.

→ A 115 - 117 Fluid coolers
→ A 137 - 138 Protection grid for axial fans
→ D 15 - 25 Thermally conductive foil
→ D 26 - 35 Technical introduction

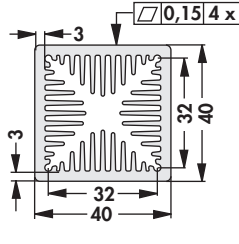
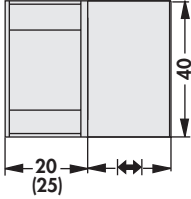
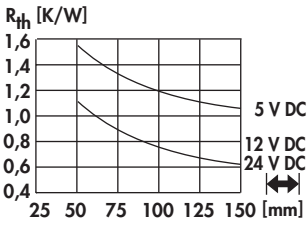

→ A 131 - 133
→ D 36
→ E 5 - 15
→ A 2 - 8

Miniature cooling aggregates

- compact design
- homogeneous heat dissipation
- mounting possible on any side
- powerful axial-fan motor
- other lengths, special designs and processing according to customer's requirements
- other surfaces treatment, fan types and fan voltages on request

art. no.				
LAM 4 ...				
please indicate:	...  50 75 100 125 150 mm		... fan type 5 = 5 V DC 12 = 12 V DC 24 = 24 V DC	
surface:	natural colour anodised			

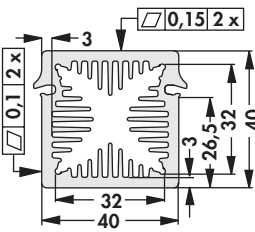
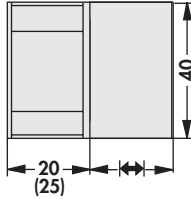
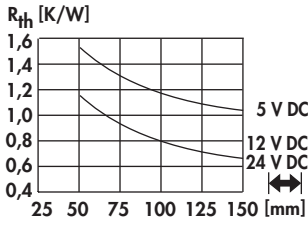
- with grooves for lock-in retaining spring for transistors THFU → A 119
- compact design
- homogeneous heat dissipation
- mounting possible on any side
- powerful axial-fan motor
- other lengths, special designs and processing according to customer's requirements
- other surfaces treatment, fan types and fan voltages on request

art. no.				
LAM 4 K ...				
please indicate:	...  50 75 100 125 150 mm		... fan type 5 = 5 V DC 12 = 12 V DC 24 = 24 V DC	
surface:	natural colour anodised			

Technical data of the fans

	... 5	... 12	... 24
type	ebmpapst 405	ebmpapst 412 JHH	ebmpapst 414 JHH
dimensions	40x40x20 mm	40x40x25 mm	40x40x25 mm
tension	5 V DC	12 V DC	24 V DC
power inout	0.9 W	3.3 W	3.6 W
max. air volume	10 m ³ /h	24 m ³ /h	24 m ³ /h
temperature range	-20°C... +70°C	-20°C... +60°C	-20°C... +60°C
noise level	18 dB(A)	46 dB(A)	46 dB(A)
speed	6,000 min ⁻¹	13,000 min ⁻¹	13,000 min ⁻¹
weight	27 g	50 g	50 g
failure rate (L₁₀)	L ₁₀ < 50,000 h (40°C) L ₁₀ < 20,000 h (tmax)	L ₁₀ < 57,500 h (40°C) L ₁₀ < 35,000 h (tmax)	L ₁₀ < 57,500 h (40°C) L ₁₀ < 35,000 h (tmax)

Miniature cooling aggregates

- compact design
- homogeneous heat dissipation
- mounting possible on any side
- powerful axial-fan motor
- other lengths, special designs and processing according to customer's requirements
- other surfaces treatment, fan types and fan voltages on request

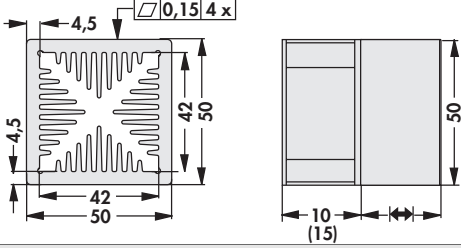
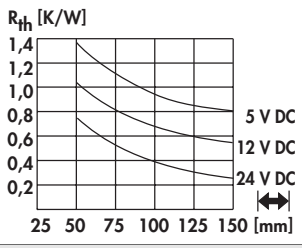
art. no.			
LAM 5 ...			
please indicate:	... $\left[\begin{array}{c} \text{---} \\ \text{---} \end{array} \right]$ 50 75 100 125 150 mm		... fan type 5 = 5 V DC 12 = 12 V DC 24 = 24 V DC
surface:	natural colour anodised		

- with grooves for lock-in retaining spring for transistors THFU → A 119
- compact design
- homogeneous heat dissipation
- mounting possible on any side
- powerful axial-fan motor
- other lengths, special designs and processing according to customer's requirements
- other surfaces treatment, fan types and fan voltages on request

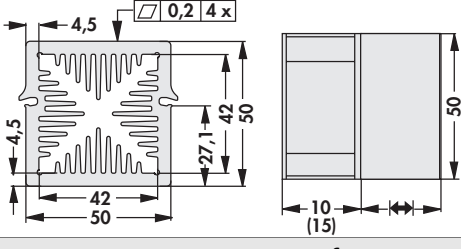
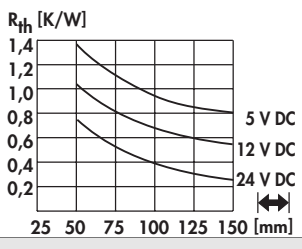
art. no.			
LAM 5 K ...			
please indicate:	... $\left[\begin{array}{c} \text{---} \\ \text{---} \end{array} \right]$ 50 75 100 125 150 mm		... fan type 5 = 5 V DC 12 = 12 V DC 24 = 24 V DC
surface:	natural colour anodised		

Technical data of the fans

	... 5	... 12	... 24
type	Sepa, ball bearing	Sepa, ball bearing	ebmpapst
dimensions	50x50x10 mm	50x50x10 mm	50x50x15 mm
tension	5 V DC	12 V DC	24 V DC
max. air volume	10 m ³ /h	14.3 m ³ /h	20 m ³ /h
temperature range	-10°C... +70°C	-10°C... +70°C	-20°C... +70°C
speed	3,400 min ⁻¹	4,800 min ⁻¹	5,000 min ⁻¹
noise level	17 dB(A)	22 dB(A)	30 dB(A)
weight	19 g	19 g	27 g
failure rate (L₁₀)	L ₁₀ < 95,000 h (20°C) MTBF < 280,000 h (20°C)	L ₁₀ < 95,000 h (20°C) MTBF < 280,000 h (20°C)	L ₁₀ 50,000 h (20°C)
alarm output	with	with	

Retaining springs for transistors
Special heatsink design
Hollow-fin cooling aggregates
High capacity cooling aggregat.



→ A 115 - 117 Fluid coolers
→ A 137 - 138 Protection grid for axial fans
→ D 15 - 25 Thermally conductive foil
→ D 26 - 35 Technical introduction

→ A 131 - 133
→ D 36
→ E 5 - 15
→ A 2 - 8

Cooling aggregates with axial fan

Heatsink-cooling aggregates

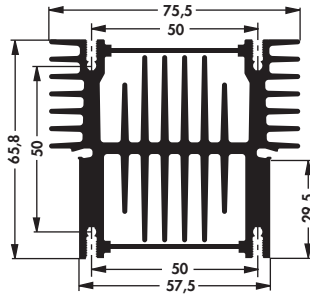
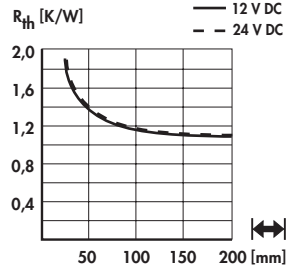
- with grooves for lock-in retaining springs THFU → A 119
- screw-in solder pin M 3 (**art. no.: ELS 3**)
- different lengths, special designs and machinings according to customer specifications
- different surfaces, fan types and fan voltages upon request

art. no.			
LA 27 K ...			
please indicate:	...  50 75 84 94 100 125 150 mm	... fan type	12 = 12 V DC 24 = 24 V DC



Technical data of the fans

	... 12	... 24
type	ebmpapst, ball bearing	ebmpapst, ball bearing
dimensions	60x60x25 mm	60x60x25 mm
tension	12 V DC	24 V DC
power inout	2.9 W	2.9 W
max. air volume	56 m ³ /h	56 m ³ /h
temperature range	-20°C... +70°C	-20°C... +70°C
noise level	41 dB(A)	41 dB(A)
speed	6,800 min ⁻¹	6,850 min ⁻¹
weight	66 g	66 g
failure rate (L₁₀)	L ₁₀ < 60,000 h (40°C)	L ₁₀ < 60,000 h (40°C)

Cooling aggregates with axial fan

Heatsink-cooling aggregates

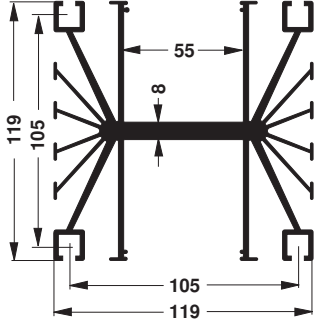
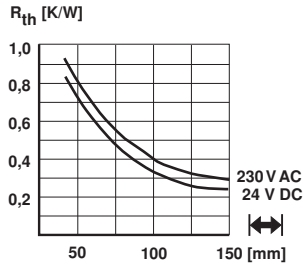
- especially suitable for IGBT, SSR, semiconductor modules, high performance transistors etc.
- effective construction with axial fans
- good thermal performance
- additional machining according to customer's instructions
- cooling aggregates also available without fans
- other fan types and fan voltages on request

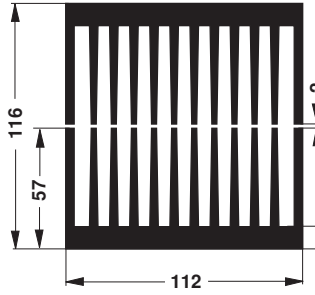
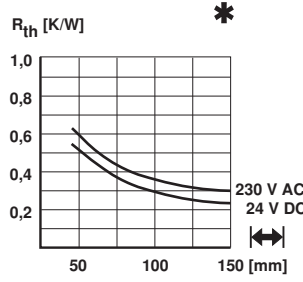
art. no. LA 4 ...			
art. no. LA 5 ...			
LA 5 ... * for one segment			
please indicate: ... $\left[\begin{array}{c} \text{---} \\ \text{---} \end{array} \right]$ 75 100 150 mm		... fan type 24 = 24 V DC 230 = 230 V AC	

Technical data of the fans

	... 24	... 230
type	ebmpapst, ball bearing	ebmpapst, ball bearing
dimensions	119x119x38 mm	119x119x38 mm
tension	24 V DC	230 V AC
power inout	11 W	19 W
max. air volume	237 m ³ /h	160 m ³ /h
temperature range	-30°C ... +70°C	-40°C... +85°C
noise level	57 dB(A)	47 dB(A)
speed	4,400 min ⁻¹	2,650 min ⁻¹
weight	390 g	550 g
failure rate (L₁₀)	L ₁₀ < 70,000 h (40°C)	L ₁₀ < 37,500 h (40°C)







Cooling aggreg. in segment mount. → D 5 - 7
 Miniature cooling aggregates → D 9 - 11
 Protection grid for axial fans → D 36
 Thermal conductive material → E 2 - 29

Extruded heatsinks → A 22 - 83
 Cooling aggregates with radial fan → D 33 - 35
 Heatsinks with hollow fin profile → D 30
 Technical introduction → A 2 - 8

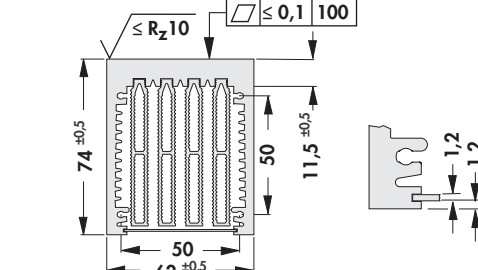
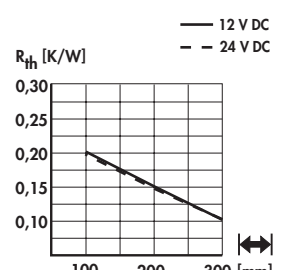
Cooling aggregates with axial fan

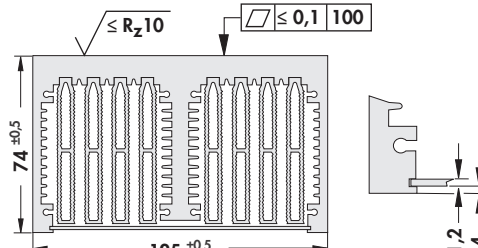
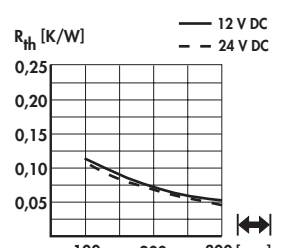
Hollow-fin cooling aggregates

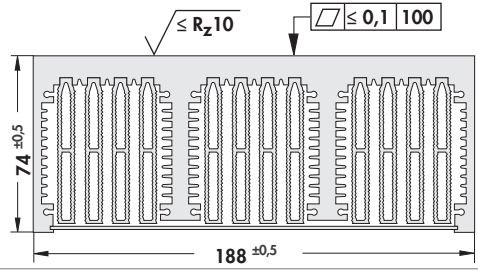
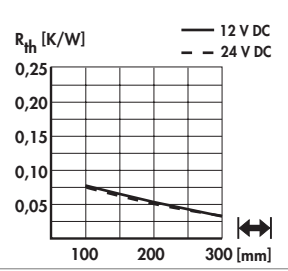
- geometry of hollow fin optimising the air flow
- particularly effective heat dissipation
- compact construction
- milled flat semiconductor mounting surface
- other fan types and fan voltages on request

<p>art. no.</p>			
<p>LA 6 ...</p>	<p>without air flow chamber</p>		
<p>art. no.</p>			
<p>LA 7 ...</p>	<p>without air flow chamber</p>		
<p>art. no.</p>			
<p>LA 8 ...</p>	<p>without air flow chamber</p>		
<p>please indicate: ...  100 150 200 250 300 mm</p>		<p>... fan type 12 = 12 V DC 24 = 24 V DC</p>	





Technical data of the fans

	... 12	... 24
type	ebmpapst, ball bearing	ebmpapst, ball bearing
dimensions	60x60x25 mm	60x60x25 mm
tension	12 V DC	24 V DC
power inout	2.9 W	2.9 W
max. air volume	56 m ³ /h	56 m ³ /h
temperature range	-20°C... +70°C	-20°C... +70°C
noise level	41 dB(A)	41 dB(A)
speed	6,800 min ⁻¹	6,850 min ⁻¹
weight	66 g	66 g
failure rate (L₁₀)	L ₁₀ < 60,000 h (40°C)	L ₁₀ < 60,000 h (40°C)

Cooling aggregates with axial fan

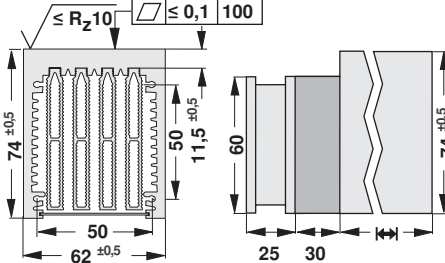
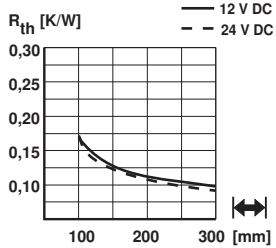
Hollow-fin cooling aggregates

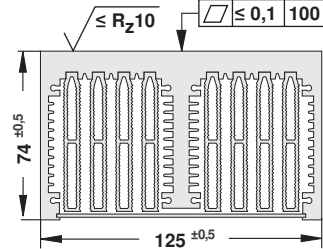
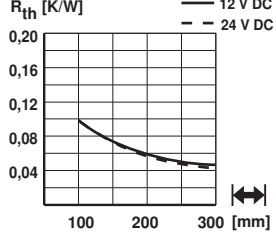
- geometry of hollow fin optimising the air flow
- particularly effective heat dissipation
- compact construction
- milled flat semiconductor mounting surface
- other fan types and fan voltages on request

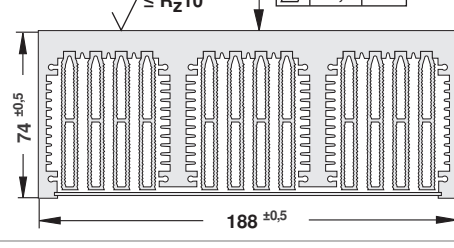
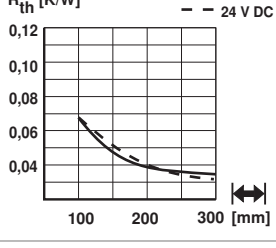
art. no. LA V 6 ...			
with air flow chamber			
art. no. LA V 7 ...			
with air flow chamber			
art. no. LA V 8 ...			
with air flow chamber			
please indicate: ... \longleftrightarrow 100 150 200 250 300 mm		... fan type 12 = 12 V DC 24 = 24 V DC	

Technical data of the fans

	... 12	... 24
type	ebmpapst, ball bearing	ebmpapst, ball bearing
dimensions	60x60x25 mm	60x60x25 mm
tension	12 V DC	24 V DC
power inout	2.9 W	2.9 W
max. air volume	56 m ³ /h	56 m ³ /h
temperature range	-20°C... +70°C	-20°C... +70°C
noise level	41 dB(A)	41 dB(A)
speed	6,800 min ⁻¹	6,850 min ⁻¹
weight	66 g	66 g
failure rate (L₁₀)	L ₁₀ < 60,000 h (40°C)	L ₁₀ < 60,000 h (40°C)







Miniature cooling aggregates → D 9 – 11
 Protection grid for axial fans → D 36
 Drilling pattern for Solid State Relais → A 12
 High capacity heatsinks → A 57 – 58

Special heatsink design → A 137 – 138
 Heatsinks with hollow fin profile → D 30
 Thermal conductive material → E 2 – 24
 Technical introduction → A 2 – 8

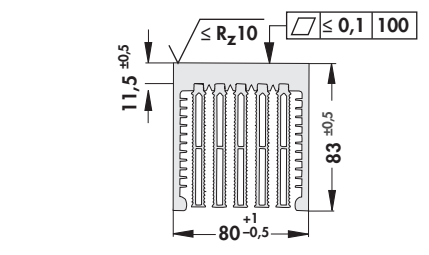
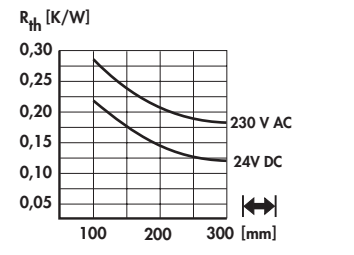
Cooling aggregates with axial fan

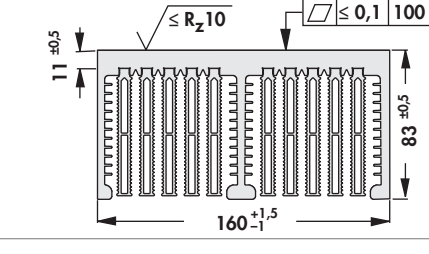
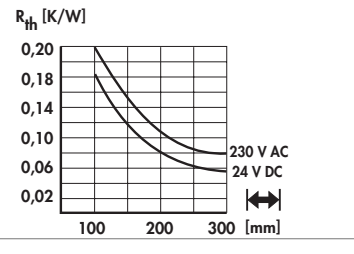
Hollow-fin cooling aggregates

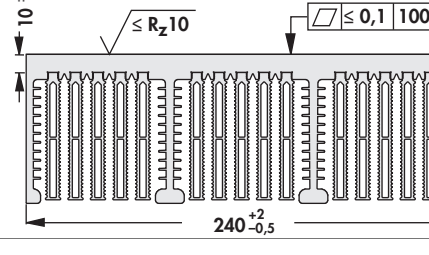
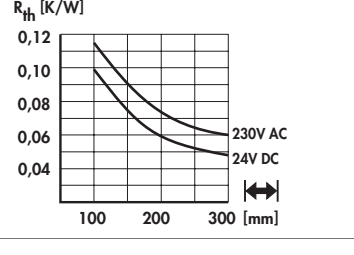
- geometry of hollow fin optimising the air flow
- particularly effective heat dissipation
- compact construction
- milled flat semiconductor mounting surface
- other fan types and fan voltages on request

<p>art. no.</p> <p>LA 9 ...</p>					
<p>without air flow chamber</p>		<p>art. no.</p> <p>LA 10 ...</p>			
<p>without air flow chamber</p>		<p>art. no.</p> <p>LA 11 ...</p>			
<p>please indicate: ... </p>		<p>... fan type</p>		<p>24 = 24 V DC 230 = 230 V AC</p>	
<p>100 150 200 250 300 mm</p>					







Technical data of the fans

	... 24	... 230
type	ebmpapst, ball bearing	ebmpapst, ball bearing
dimensions	80x80x32 mm	80x80x38 mm
tension	24 V DC	230 V AC
power inout	6 W	12 W
max. air volume	80 m ³ /h	50 m ³ /h
temperature range	-20°C... 75°C	-40°C... +90°C
noise level	48 dB(A)	31 dB(A)
speed	5,000 min ⁻¹	2,800 min ⁻¹
weight	170 g	490 g
failure rate (L₁₀)	L ₁₀ < 55,000 h (40°C)	L ₁₀ < 52,500 h (40°C)

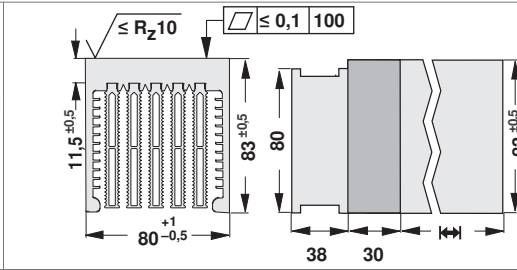
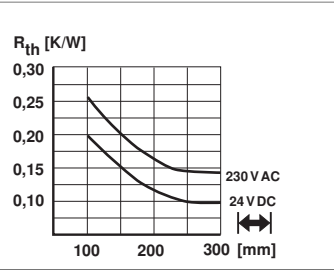
Cooling aggregates with axial fan

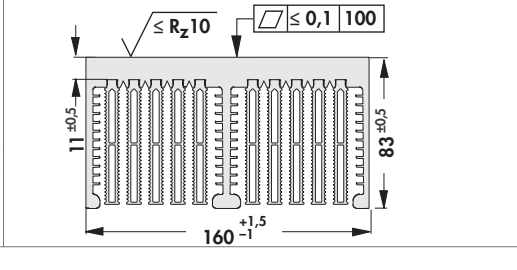
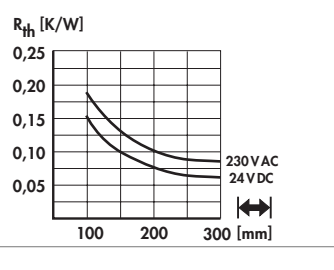
Hollow-fin cooling aggregates

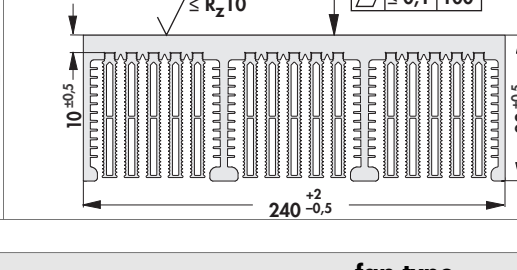
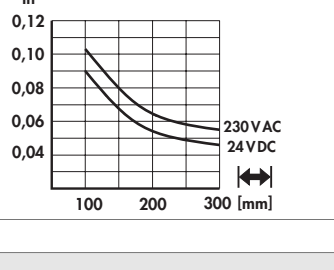
- geometry of hollow fin optimising the air flow
- particularly effective heat dissipation
- compact construction
- milled flat semiconductor mounting surface
- other fan types and fan voltages on request

art. no.			
LA V 9 ...	with air flow chamber		
art. no.			
LA V 10 ...	with air flow chamber		
art. no.			
LA V 11 ...	with air flow chamber		
please indicate:	...  100 150 200 250 300 mm	... fan type	24 = 24 V DC 230 = 230 V AC

Technical data of the fans

	... 24	... 230
type	ebmpapst, ball bearing	ebmpapst, ball bearing
dimensions	80x80x32 mm	80x80x38 mm
tension	24 V DC	230 V AC
power inout	6 W	12 W
max. air volume	80 m ³ /h	50 m ³ /h
temperature range	-20°C... 75°C	-40°C... +90°C
noise level	48 dB(A)	31 dB(A)
speed	5,000 min ⁻¹	2,800 min ⁻¹
weight	170 g	490 g
failure rate (L₁₀)	L ₁₀ < 55,000 h (40°C)	L ₁₀ < 52,500 h (40°C)



Miniature cooling aggregates → D 9 – 11
 Protection grid for axial fans → D 36
 Drilling pattern for Solid State Relais → A 12
 High capacity heatsinks → A 57 – 58

Special heatsink design → A 137 – 138
 Heatsinks with hollow fin profile → D 30
 Thermal conductive material → E 2 – 24
 Technical introduction → A 2 – 8

Cooling aggregates with axial fan

Hollow-fin cooling aggregates

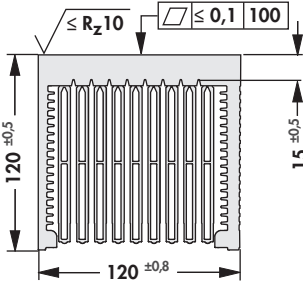
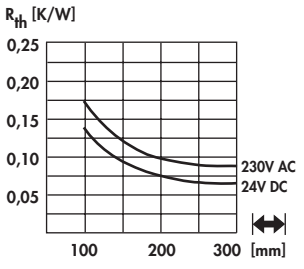
- extremely low losses due to optimised hollow fin geometry
- particularly effective heat dissipation
- compact design with axial fan
- milled flat semiconductor mounting surface
- additional design to customer's instructions
- other fan types and fan voltages on request

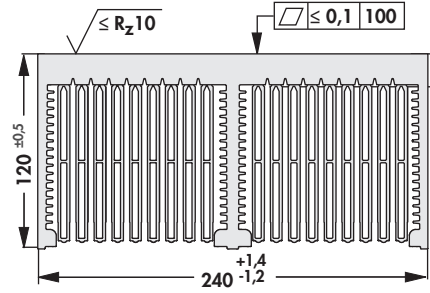
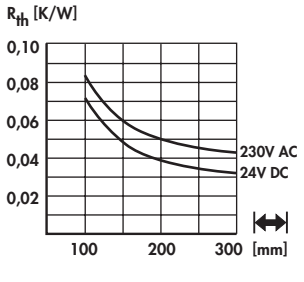
art. no.			
LA 14 ...	without air flow chamber		
art. no.			
LA 15 ...	without air flow chamber		
please indicate: ... \longleftrightarrow		... fan type	
100 150 200 250 300 400 mm		24 = 24 V DC 230 = 230 V AC	





Technical data of the fans

	... 24	... 230
type	ebmpapst, ball bearing	ebmpapst, ball bearing
dimensions	119x119x38 mm	119x119x38 mm
tension	24 V DC	230 V AC
power inout	11 W	19 W
max. air volume	237 m ³ /h	160 m ³ /h
temperature range	-30°C ... +70°C	-40°C... +85°C
noise level	57 dB(A)	47 dB(A)
speed	4,400 min ⁻¹	2,650 min ⁻¹
weight	390 g	550 g
failure rate (L₁₀)	L ₁₀ < 70,000 h (40°C)	L ₁₀ < 37,500 h (40°C)

Cooling aggregates with axial fan

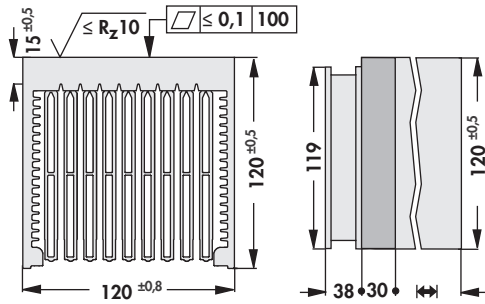
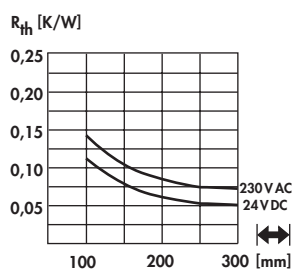
Hollow-fin cooling aggregates

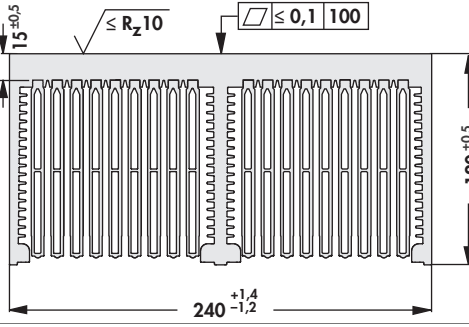
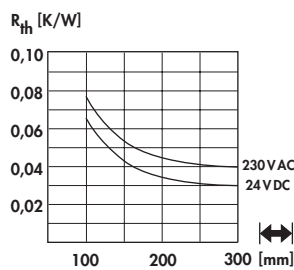
- extremely low losses due to optimised hollow fin geometry
- particularly effective heat dissipation
- compact design with axial fan
- milled flat semiconductor mounting surface
- additional design to customer's instructions on request
- other fan types and fan voltages on request

art. no.			
LA V 14 ...	with air flow chamber		
art. no.			
LA V 15 ...	with air flow chamber		
please indicate:	...  100 150 200 250 300 400 mm	... fan type	24 = 24 V DC 230 = 230 V AC

Technical data of the fans

	... 24	... 230
type	ebmpapst, ball bearing	ebmpapst, ball bearing
dimensions	119x119x38 mm	119x119x38 mm
tension	24 V DC	230 V AC
power inout	11 W	19 W
max. air volume	237 m ³ /h	160 m ³ /h
temperature range	-30°C ... +70°C	-40°C... +85°C
noise level	57 dB(A)	47 dB(A)
speed	4,400 min ⁻¹	2,650 min ⁻¹
weight	390 g	550 g
failure rate (L₁₀)	L ₁₀ < 70,000 h (40°C)	L ₁₀ < 37,500 h (40°C)

Miniature cooling aggregates

→ D 9 - 11

Protection grid for axial fans

→ D 36

Drilling pattern for Solid State Relais

→ A 12

High capacity heatsinks

→ A 57 - 58

Special heatsink design

→ A 137 - 138

Heatsinks with hollow fin profile

→ D 30

Thermal conductive material

→ E 2 - 24





Technical introduction

→ A 2 - 8

Cooling aggregates with axial fan

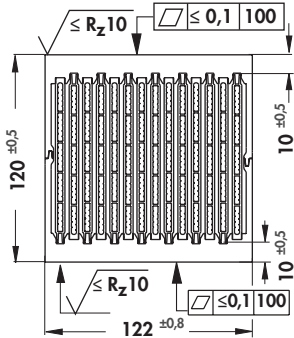
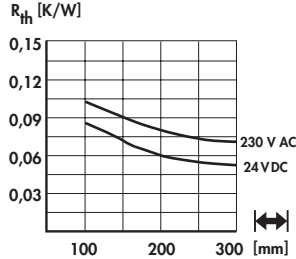
Hollow-fin cooling aggregates

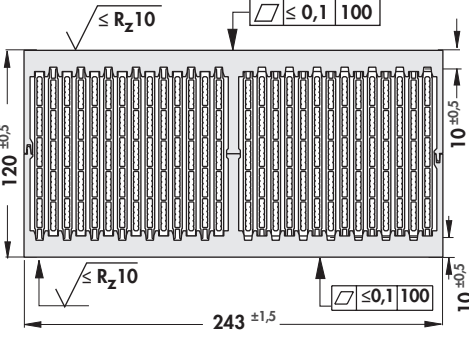
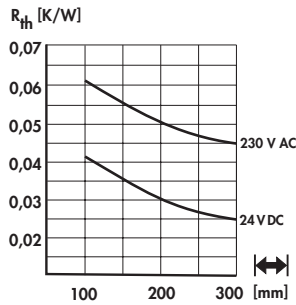
- extremely low losses due to optimised hollow fin geometry
- effective heat dissipation
- compact construction with axial fans
- two opposite mounting surfaces are milled flat
- additional treatment upon customer's request
- other fan types and fan voltages on request

art. no.			
LA 17 ...	without air flow chamber		
art. no.			
LA 18 ...	without air flow chamber		
please indicate: ... 		... fan type	
100 150 200 250 300 400 mm		24 = 24 V DC 230 = 230 V AC	





Technical data of the fans

	... 24	... 230
type	ebmpapst, ball bearing	ebmpapst, ball bearing
dimensions	119x119x38 mm	119x119x38 mm
tension	24 V DC	230 V AC
power inout	11 W	19 W
max. air volume	237 m ³ /h	160 m ³ /h
temperature range	-30°C ... +70°C	-40°C... +85°C
noise level	57 dB(A)	47 dB(A)
speed	4,400 min ⁻¹	2,650 min ⁻¹
weight	390 g	550 g
failure rate (L₁₀)	L ₁₀ < 70,000 h (40°C)	L ₁₀ < 37,500 h (40°C)

Cooling aggregates with axial fan

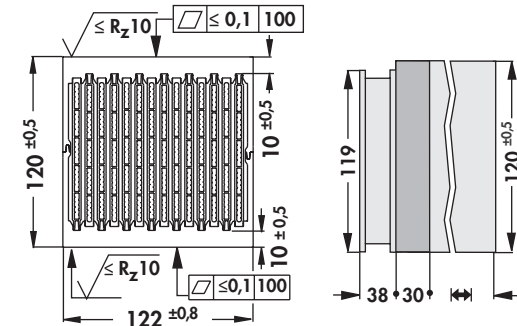
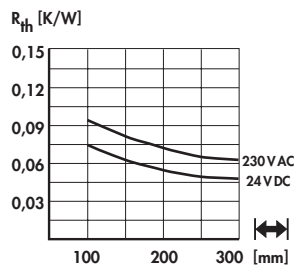
Hollow-fin cooling aggregates

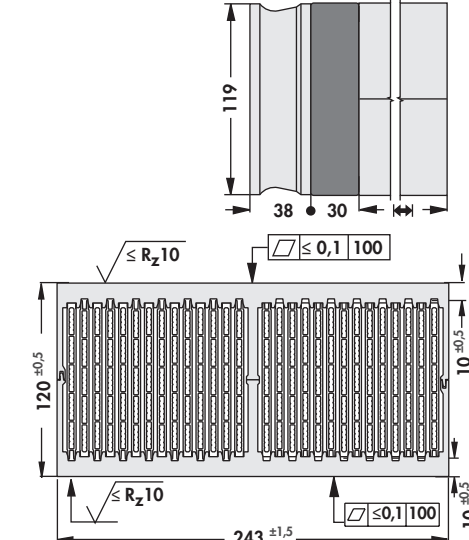
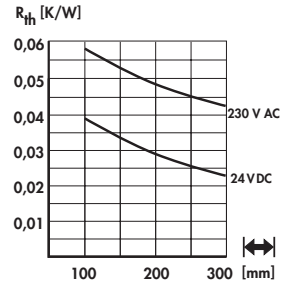
- extremely low losses due to optimised hollow fin geometry
- effective heat dissipation
- compact construction with axial fans
- two opposite mounting surfaces are milled flat
- additional treatment upon customer's request
- other fan types and fan voltages on request

art. no. 		
LA V 17 ...	with air flow chamber	
art. no. 		
LA V 18 ...	with air flow chamber	
please indicate: ...  100 150 200 250 300 400 mm		
... fan type 24 = 24 V DC 230 = 230 V AC		

Technical data of the fans

	... 24	... 230
type	ebmpapst, ball bearing	ebmpapst, ball bearing
dimensions	119x119x38 mm	119x119x38 mm
tension	24 V DC	230 V AC
power inout	11 W	19 W
max. air volume	237 m ³ /h	160 m ³ /h
temperature range	-30°C ... +70°C	-40°C... +85°C
noise level	57 dB(A)	47 dB(A)
speed	4,400 min ⁻¹	2,650 min ⁻¹
weight	390 g	550 g
failure rate (L₁₀)	L ₁₀ < 70,000 h (40°C)	L ₁₀ < 37,500 h (40°C)

Miniature cooling aggregates

→ D 9 - 11

Protection grid for axial fans

→ D 36

Drilling pattern for Solid State Relais

→ A 12

High capacity heatsinks

→ A 57 - 58

Special heatsink design

→ A 137 - 138

Heatsinks with hollow fin profile

→ D 30

Thermal conductive material

→ E 2 - 24



Technical introduction

→ A 2 - 8

Cooling aggregates with axial fan

Hollow-fin cooling aggregates

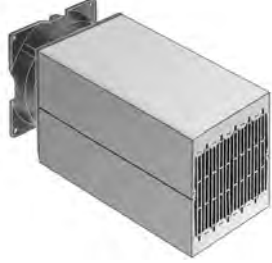
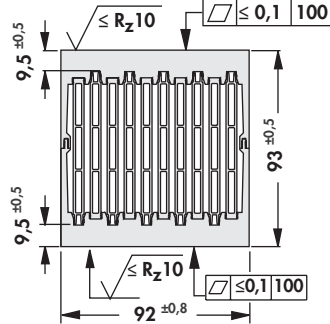
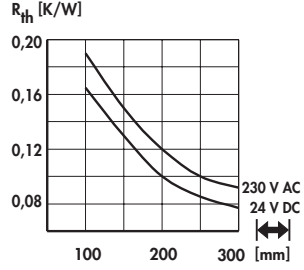
- extremely low losses due to optimised hollow fin geometry
- effective heat dissipation
- compact construction with axial fans
- two opposite mounting surfaces are milled flat
- additional treatment upon customer's request
- other fan types and fan voltages on request

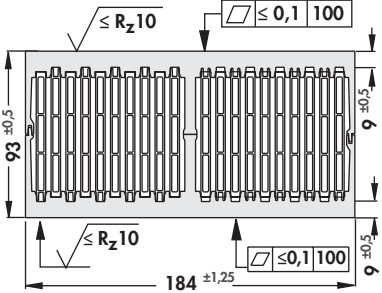
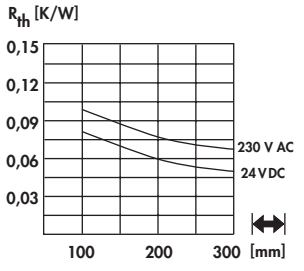
art. no.			
LA 21 ...	without air flow chamber		
art. no.			
LA 22 ...	without air flow chamber		
please indicate: ... 100 150 200 250 300 400 mm		... fan type 24 = 24 V DC 230 = 230 V AC	



Technical data of the fans

	... 24	... 230
type	ebmpapst, ball bearing	ebmpapst, ball bearing
dimensions	92x92x32 mm	92x92x38 mm
tension	24 V DC	230 V AC
power inout	5 W	12 W
max. air volume	107 m ³ /h	75 m ³ /h
temperature range	-20°C... 75°C	-40°C... +75°C
noise level	47 dB(A)	37 dB(A)
speed	4,000 min ⁻¹	2,700 min ⁻¹
weight	190 g	420 g
failure rate (L₁₀)	L ₁₀ < 57,500 h (40°C)	L ₁₀ < 52,500 h (40°C)

Cooling aggregates with axial fan

Hollow-fin cooling aggregates

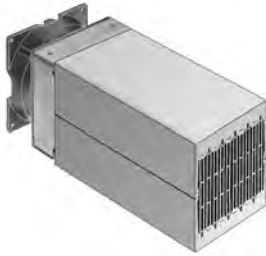
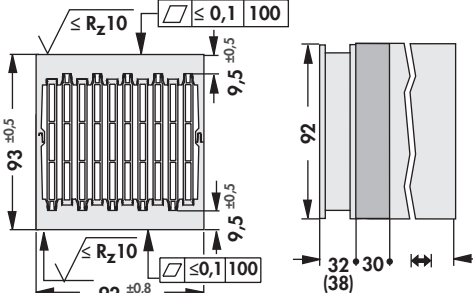
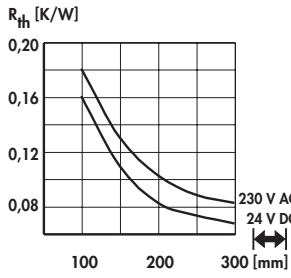
- extremely low losses due to optimised hollow fin geometry
- effective heat dissipation
- compact construction with axial fans
- two opposite mounting surfaces are milled flat
- additional treatment upon customer's request
- other fan types and fan voltages on request

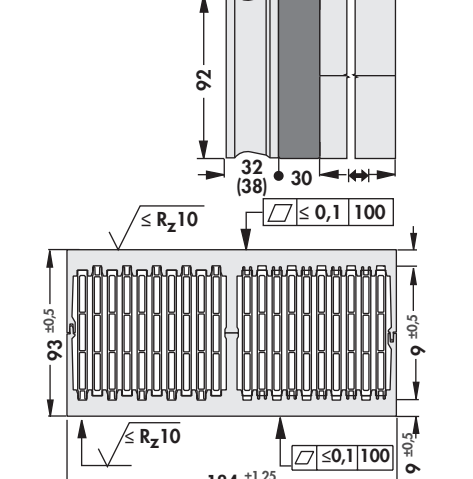
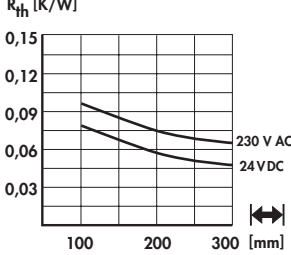
art. no. LA V 21 ...			
with air flow chamber			
art. no. LA V 22 ...			
with air flow chamber			
please indicate: ... < > 100 150 200 250 300 400 mm		... fan type 24 = 24 V DC 230 = 230 V AC	

Technical data of the fans

	... 24	... 230
type	ebmpapst, ball bearing	ebmpapst, ball bearing
dimensions	92x92x32 mm	92x92x38 mm
tension	24 V DC	230 V AC
power inout	5 W	12 W
max. air volume	107 m ³ /h	75 m ³ /h
temperature range	-20°C... 75°C	-40°C... +75°C
noise level	47 dB(A)	37 dB(A)
speed	4,000 min ⁻¹	2,700 min ⁻¹
weight	190 g	420 g
failure rate (L₁₀)	L ₁₀ < 57,500 h (40°C)	L ₁₀ < 52,500 h (40°C)

Miniature cooling aggregates → D 9 - 11
 Protection grid for axial fans → D 36
 Drilling pattern for Solid State Relais → A 12
 High capacity heatsinks → A 57 - 58

Special heatsink design → A 137 - 138
 Heatsinks with hollow fin profile → D 30
 Thermal conductive material → E 2 - 24
 Technical introduction → A 2 - 8

Cooling aggregates with axial fan

Hollow-fin cooling aggregates

- extremely low losses due optimised hollow fin geometry
- especially effective heat dissipation
- compact construction with axial fans
- two opposite mounting surfaces are milled flat
- additional treatment upon customer's request
- other fan types and fan voltages on request

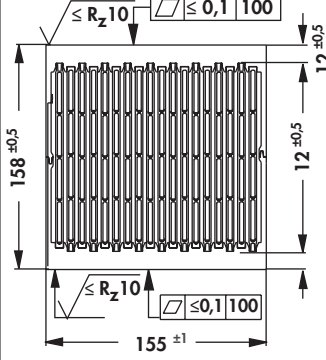
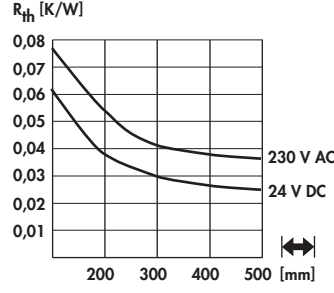
art. no.			
LA V 24 ...	with air flow chamber		
please indicate: ... $\left[\begin{array}{c} \leftarrow \rightarrow \\ 200 \quad 300 \quad 400 \text{ mm} \end{array} \right]$... fan type 24 = 24 V DC 230 = 230 V AC	

Technical data of the fans

	... 24	... 230
type	ebmpapst, ball bearing, with grid	ebmpapst, ball bearing, with grid
dimensions	Ø150x38 mm	Ø150x55 mm
tension	24 V DC	230 V AC
power in/out	19 W	47 W
max. air volume	420 m ³ /h	380 m ³ /h
temperature range	-25°C... +72°C	-30°C... +60°C
noise level	59 dB(A)	60 dB(A)
speed	3,350 min ⁻¹	2,700 min ⁻¹
weight	620 g	1,100 g
failure rate (L₁₀)	L ₁₀ < 75,000 h (40°C)	L ₁₀ < 40,000 h (40°C)

Cooling aggregates with axial fan

High performance cooling aggregate



extremely low losses of air flow as compared to cooling aggregates with extruded aluminium

- compact dimensions, that means high performance density due to large heat-conducting surfaces
- maximum heat flow due to brazing or thermal adhesion
- high performance cooling aggregates are only effective with forced ventilation by means of the fan, but not with free convection
- other fan types and fan voltages on request

material: solder-plated aluminium sheet, thus minimal weight due to the thickness of the material

An optimised unit for any application can be produced from the wide range of existing components upon request. The specific capacity will be determined by a test run upon customer's request.

Technical data of the fans

	... 230
type	ebmpapst, ball bearing
dimensions	119x119x38 mm
tension	230 V AC
power inout	19 W
max. air volume	160 m ³ /h
temperature range	-40°C... +85°C
noise level	47 dB(A)
speed	2,650 min ⁻¹
weight	550 g
failure rate (L₁₀)	L ₁₀ < 37,500 h (40°C)





Miniature cooling aggregates → D 9 – 11
Protection grid for axial fans → D 36
Drilling pattern for Solid State Relais → A 12
High capacity heatsinks → A 57 – 58

Special heatsink design → A 137 – 138
Heatsinks with hollow fin profile → D 30
Thermal conductive material → E 2 – 24
Technical introduction → A 2 – 8

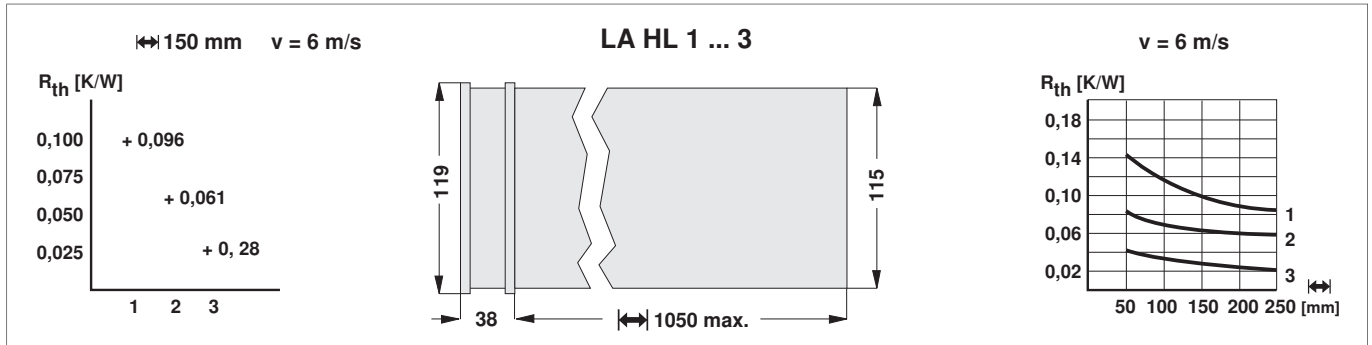
Cooling aggregates with axial fan

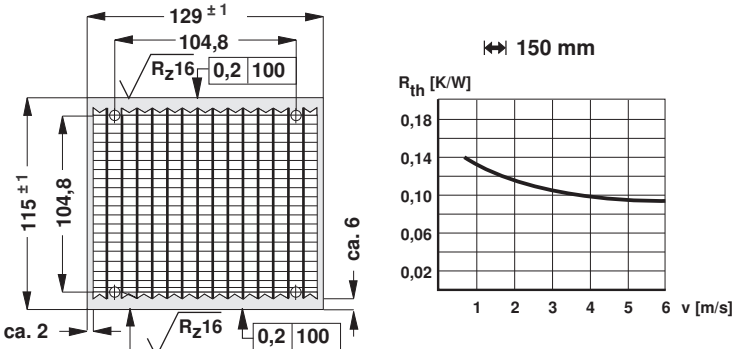
High performance cooling aggregate

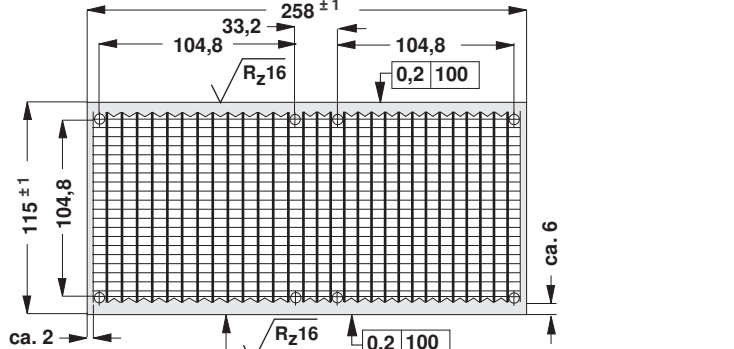

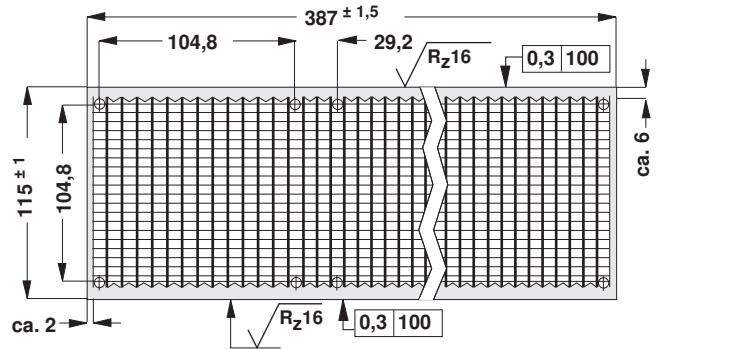
<p>art. no.</p>		
<p>LA HL 1 ...</p>	<p>without air flow chamber</p>	
<p>art. no.</p>		
<p>LA HL 2 ...</p>	<p>without air flow chamber</p>	
<p>art. no.</p>		
<p>LA HL 3 ...</p>	<p>without air flow chamber</p>	
<p>please indicate: ... \longleftrightarrow 100 150 200 250 300 400 mm</p>		

Cooling aggregates with axial fan

High performance cooling aggregate

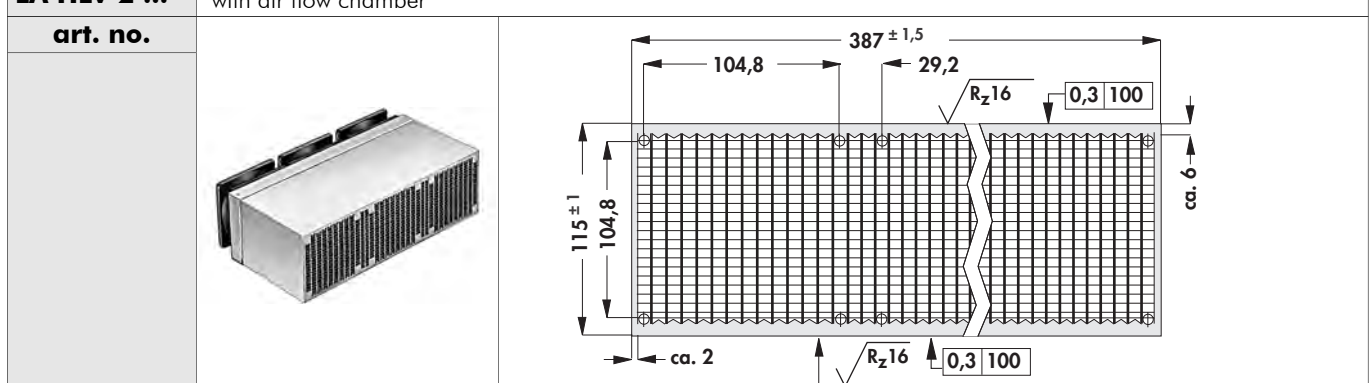
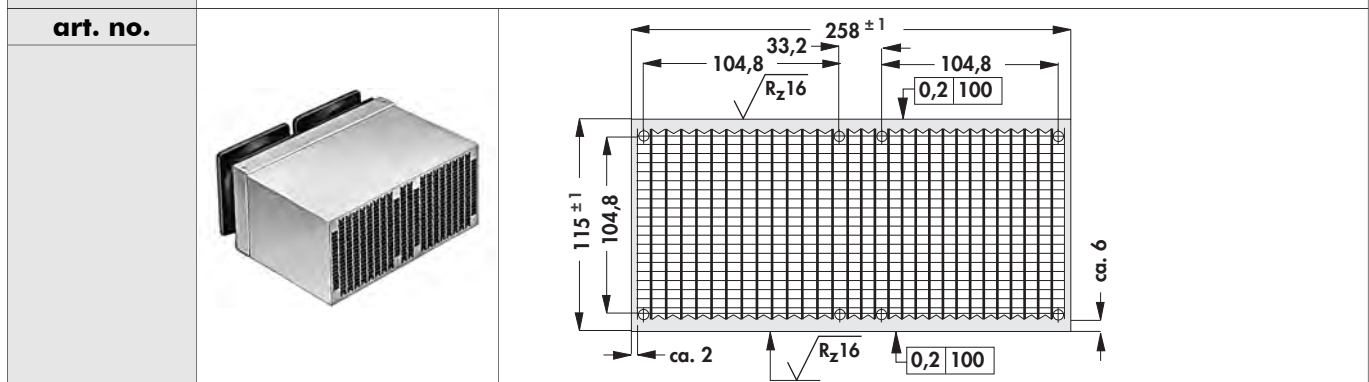
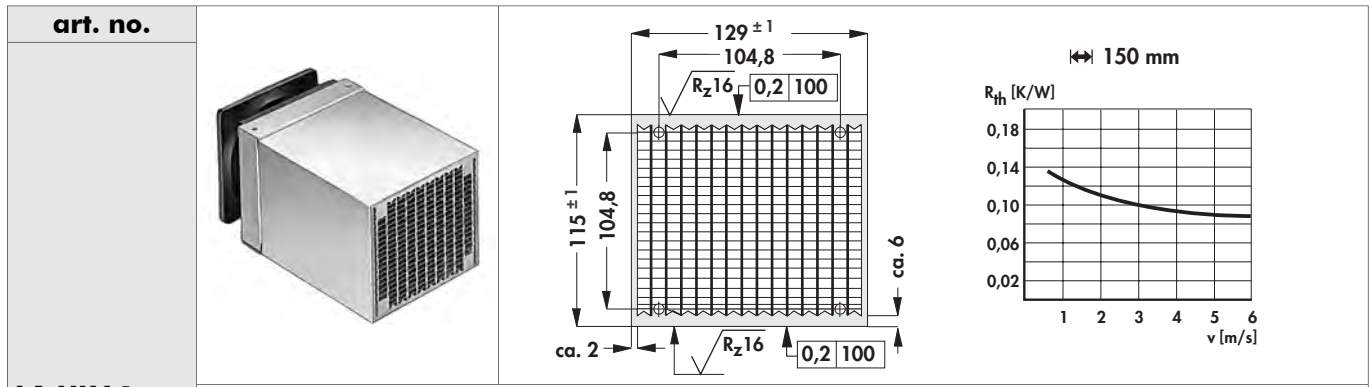
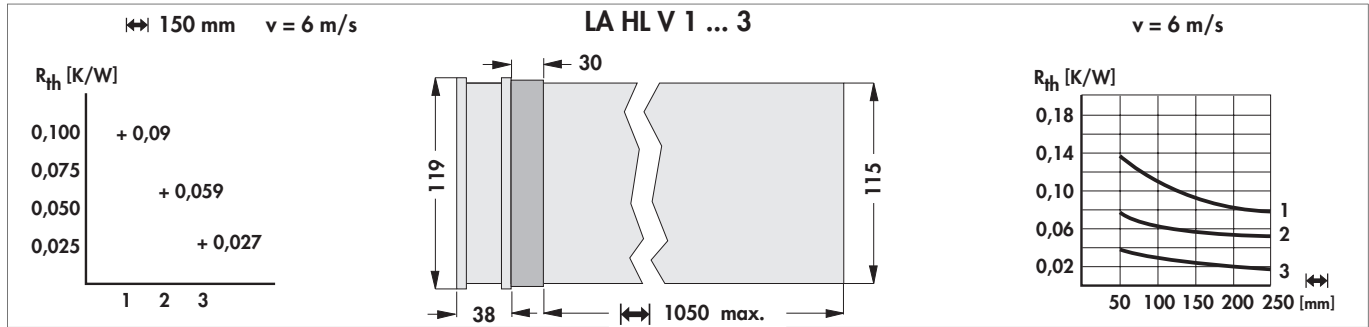



please indicate: ... \leftrightarrow 100 150 200 250 300 400 mm

Cooling aggregates with axial fan

High performance cooling aggregate

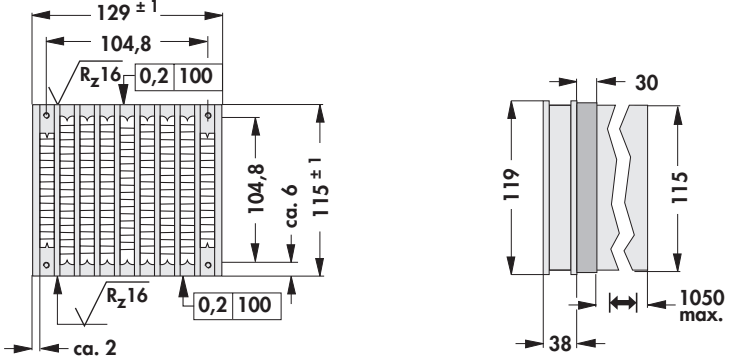
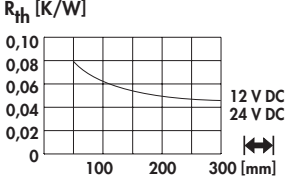
- innovative, efficient heatsink design
- thick multiwall sheets for maximum heat dissipation
- specially formed laminated structures ensure optimum heat exchange with the air flow
- powerful mixed axial fan for highly efficient heat dissipation
- reduced noise output achieved by an optimised adaption of fan and heatsink
- additional treatment and modifications upon customer's request
- double and triple versions upon request

art. no.			
LAHL D 1 ...			
please indicate:	...  100 150 200 250 300 400 mm	... fan type	12 = 12 V DC 24 = 24 V DC

Technical data of the fans

	... 12	... 24
type	ebmpapst, ball bearing, with grid	ebmpapst, ball bearing, with grid
dimensions	119x119x38 mm	119x119x38 mm
tension	12 V DC	24 V DC
power inout	21 W	19.5 W
max. air volume	310 m ³ /h	310 m ³ /h
temperature range	-20°C... +65°C	-20°C... +65°C
noise level	65 dB(A)	65 dB(A)
speed	6,000 min ⁻¹	6,000 min ⁻¹
weight	390 g	390 g
failure rate (L₁₀)	L ₁₀ > 60,000 h (40°C) L ₁₀ > 37,500 h (tmax)	L ₁₀ > 65,000 h (40°C) L ₁₀ > 37,500 h (tmax)

High-performance heatsinks

High performance heatsinks with hollow-fin profile

- high performance heatsinks for fan operation
- exclusively for forced convection
- preferably for radial or tangential fans
- hollow fin geometry optimises the air flow
- particularly effective heat dissipation
- milled flat base (except length 1000 mm)

art. no.		<p>$R_{th} [K/W] \quad v = 5 \text{ m/s}$</p>
SK 497 ...		
art. no.		<p>$R_{th} [K/W] \quad v = 5 \text{ m/s}$</p>
SK 498 ...		
please indicate:	... [mm] 150 200 250 300 1000 mm	... surface SA = black anodised AL = raw degreased aluminium

	<p>$v = 5 \text{ m/s}$ $R_{th} [K/W]$</p>			
art. no.	number of fins	dim. [mm]		
		A	B	C
SK 440 ...	15	84 ± 1	200 ± 1.2	16
SK 458 ...	19	84 ± 1	250 ± 1.4	16
SK 441 ...	23	84 ± 1	300 ± 1.6	16
SK 461 ...	31	88 ± 1	400 ± 2	20
please indicate:	... [mm] 150 200 300 1000 mm	... surface SA = black anodised AL = raw degreased aluminium		

High capacity cooling aggregat. → D 26 - 29
 Cooling aggregates with radial fan → D 33 - 35
 Heatsinks with hollow fin profile → D 30 - 31
 Hollow-fin cooling aggregates → D 15 - 25

Heatsink-cooling aggregates → D 14
 Cooling aggreg. in segment mount. → D 5
 Miniature cooling aggregates → D 9 - 11
 Technical introduction → A 2 - 8

High performance heatsinks with hollow-fin profile

- high capacity heatsinks for fan operation preferably for radial- or tangential fan motors
- universal modular design
- exclusively for forced convection
- flow-optimized hollow fin geometry
- minimum order quantity: 1000 kg, samples on request

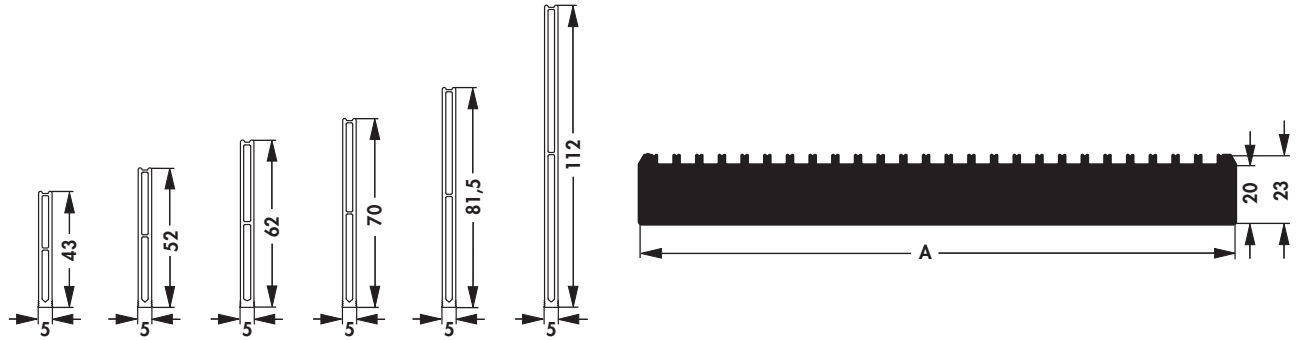

art. no.	number of fins	dim. [mm]
		A
SK 603 ...	25	200
SK 604 ...	32	250
SK 605 ...	39	300
SK 606 ...	45	350
SK 607 ...	52	400
SK 608 ...	65	500

please indicate: ... fin height
 430 = 43 mm
 520 = 52 mm
 620 = 62 mm
 700 = 70 mm
 815 = 81.5 mm
 1120 = 112 mm

... []
 200 300 400 500 mm

... surface
 SA = black anodised
 ME = clear anodised

SK 603

R_{th} [K/W] $v = 11$ m/s

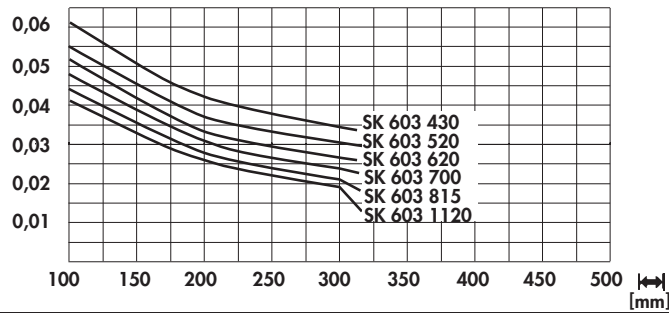

SK 604

R_{th} [K/W] $v = 11$ m/s

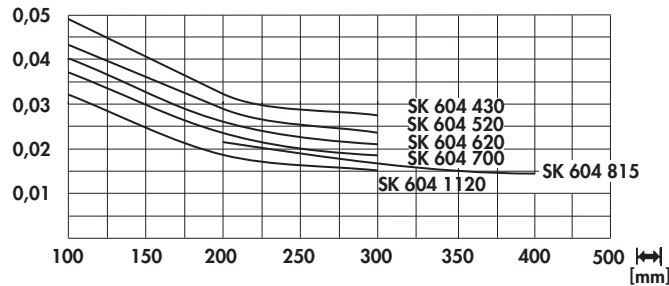

High performance heatsinks with hollow-fin profile

SK 605

R_{th} [K/W] $v = 11 \text{ m/s}$

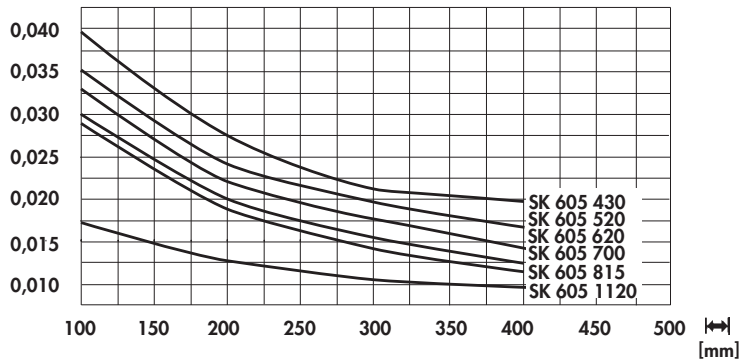

SK 606

R_{th} [K/W] $v = 11 \text{ m/s}$

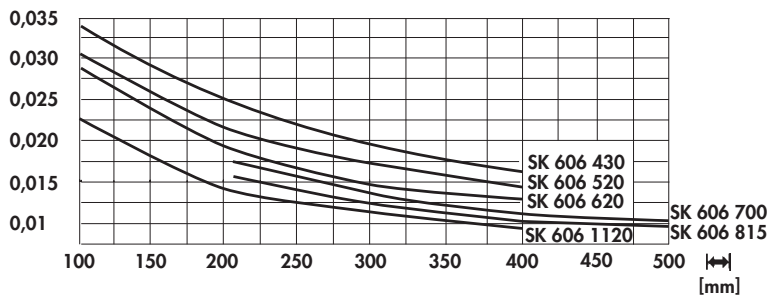

SK 607

R_{th} [K/W] $v = 11 \text{ m/s}$

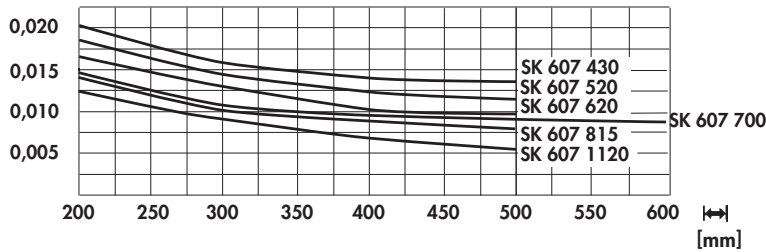

SK 608

R_{th} [K/W] $v = 11 \text{ m/s}$

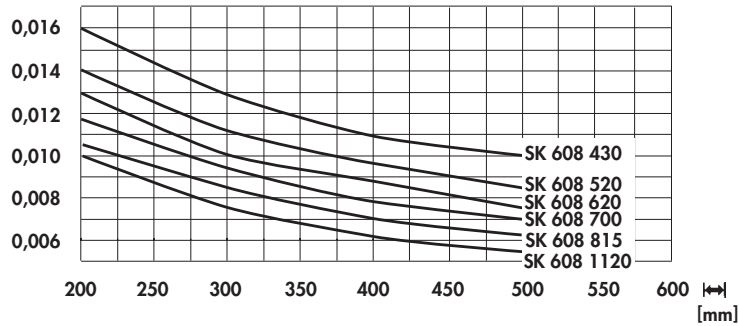

High capacity cooling aggregat. → D 26 – 29
 Cooling aggregates with radial fan → D 33 – 35
 Heatsinks with hollow fin profile → D 30 – 31
 Hollow-fin cooling aggregates → D 15 – 25

→ D 26 – 29
 → D 33 – 35
 → D 30 – 31
 → D 15 – 25





Heatsink-cooling aggregates → D 14
 Cooling aggreg. in segment mount. → D 5
 Miniature cooling aggregates → D 9 – 11
 Technical introduction → A 2 – 8

→ D 14
 → D 5
 → D 9 – 11
 → A 2 – 8

Cooling aggregates with radial fan

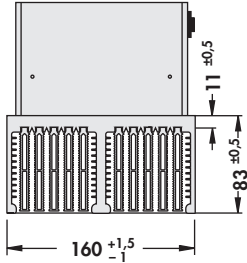
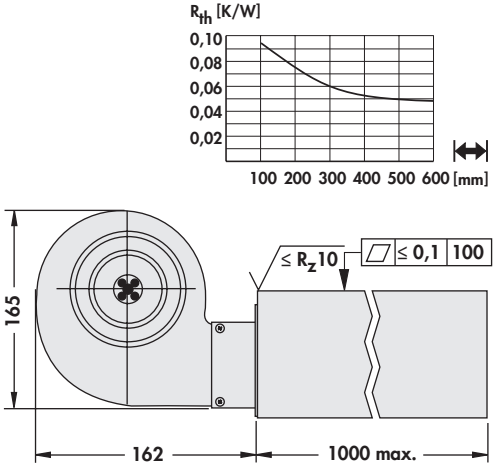
High performance cooling aggregate

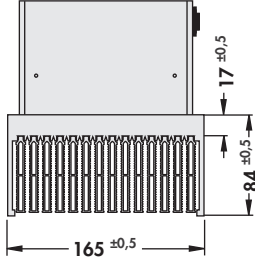
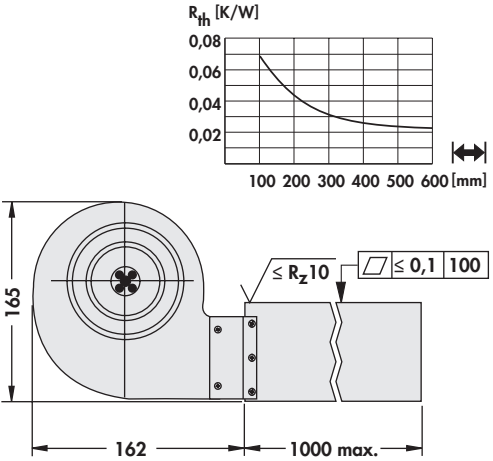
- optimised air flow due to hollow fin geometrie
- very good thermal performance
- optimized high performance construction with radial fan
- milled flat mounting surface for semiconductor
- cover plate for fin side upon request
- additional customized treatment upon request
- fan condenser: **art. no. LAHLR K 2**

art. no.			
LA 25 ...			
LA 26 ...			
<p>please indicate: ...  200 300 400 500 600 mm</p>			



Technical data of the fans

type	... 230 ebmpapst, radial blower with grid, double sided absorption
bearing type	ball bearing
discharge air flow	435 m ³ /h
rotation speed	1,950 min ⁻¹
power inout	87 W
current consumption	0.39 A
temperature range	-25°C... +40°C
circuit voltage	230 V AC
motor condenser	2 µF/400 V
noise level	58 dB(A)
weight	1,500 g

Cooling aggregates with radial fan

High performance cooling aggregate

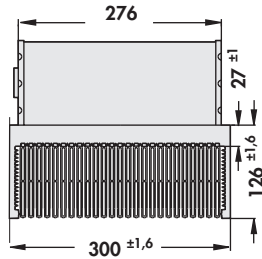
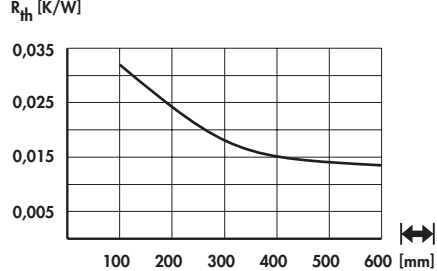
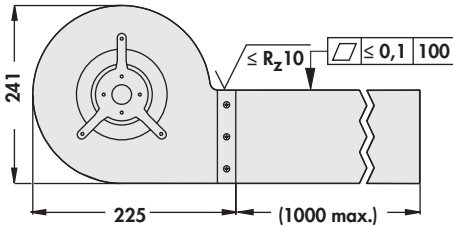
- optimised air flow due to hollow fin geometrie
- very good thermal performance
- optimized high performance construction with radial fan
- milled flat mounting surface for semiconductor
- cover plate for fin side upon request
- additional customized treatment upon request
- fan condenser: **art. no. LA 20 K 6**

art. no.			
			
LA 20 ...			
please indicate:		200 300 400 500 600 mm	

Technical data of the fans

	... 230
bearing type	ball bearing
type	ebmpapst, radial blower with grid, double sided absorbtion
discharge air flow	1,310 m ³ /h
rotation speed	1,350 min ⁻¹
power inout	185 W
current consumption	0.81 A
circuit voltage	230 V AC
temperature range	-25°C... +70°C
motor condenser	6 μF
noise level	64 dB(A)
weight	5,900 g

 Drilling pattern for Solid State Relais → **A 12**

 Mounting for TO 3 angle → **A 125 – 128**

 High capacity heatsinks → **A 57 – 58**

 Cooling aggreg. in segment mount. → **D 5 – 7**

Miniature cooling aggregates

heatsinks for Solid State Relais

Hole pattern

Technical introduction

 → **D 9 – 12**

 → **135 – 136**

 → **A 21**

 → **A 2 – 8**

Cooling aggregates with radial fan

High performance cooling aggregate

- other lengths upon request
- fan condenser: art. no. LAHLR K 2

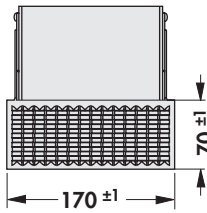
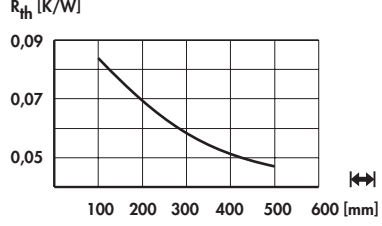
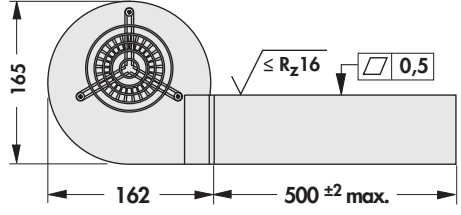
art. no.			 
LAHLR 1 500			
construction:	solid frame construction with inner animation and carrier plates, thermally connected by soldering		
weight:	6,300 g		
material:	aluminium alloy		
surface:	blanc, milled flat		

Technical data of the fans

	... 230
type	ebmpapst, radial blower with grid, double sided absorption
bearing type	ball bearing
discharge air flow	435 m ³ /h
rotation speed	1,950 min ⁻¹
power inout	87 W
current consumption	0.39 A
temperature range	-25°C... +40°C
circuit voltage	230 V AC
motor condenser	2 μF/400 V
noise level	58 dB(A)
weight	1,500 g

Protection grid for fans

- protection against contact as per EN 294
- aerodynamic construction
- minimized noise modification
- only low modification of the air flow

art. no.	suitable for cooling aggregate
LAGI 40	LAM 2/ LAM 4/ LAM 4 K
art. no.	suitable for cooling aggregate
LAGI 60	LAM 1/ LA (V) 6/ LA (V) 7/ LA (V) 8/ LA 27 K
art. no.	suitable for cooling aggregate
LAGI 80	LA (V) 9/ LA (V) 10/ LA (V) 11
art. no.	suitable for cooling aggregate
LAGI 92	LA 2/ LA (V) 21/ LA (V) 22
art. no.	suitable for cooling aggregate
LAGI 119	LA 1/ LA 4/ LA 5/ LA (V) 14/ LA (V) 15/ LA (V) 17/ LA (V) 18/ LA HL (V) 1/ LA HL (V) 2/ LA HL (V) 3 / LA HL D1
material:	steel wire, nickel-plated

High capacity cooling aggregat.
Cooling aggregates with radial fan
Heatsinks with hollow fin profile
Hollow-fin cooling aggregates

→ D 26 – 29
→ D 33 – 35
→ D 30
→ D 15 – 25

Heatsink-cooling aggregates
Cooling aggreg. in segment mount.
Miniature cooling aggregates
Technical introduction

→ D 14
→ D 5
→ D 9 – 11
→ A 2 – 8

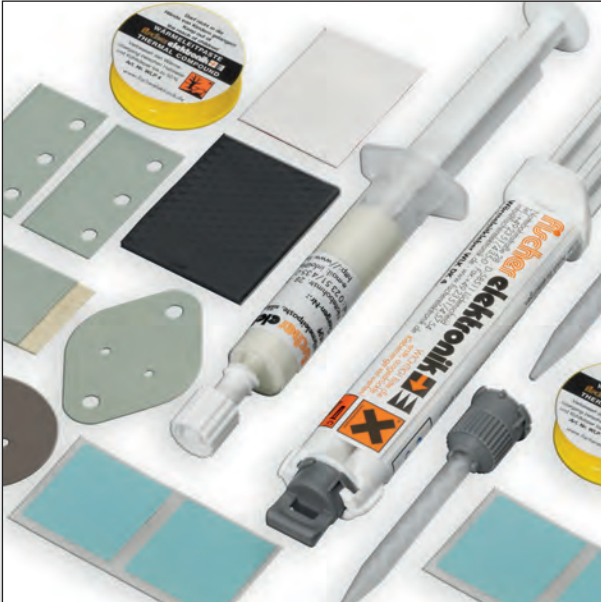

Thermal conductive material

- large standard programme for thermal conductive pastes and glues, silicone-, GEL-, and foam foils (Gap Filler), cuts, tapes, tubes and caps
- thermal conductive electrically insulating foils
- customer specific productions made in our in-house punching shop



Guide rails for PCBs

- for horizontal and vertical assembly
- suitable for sheet thicknesses of 0.5 - 1.85 mm
- with and without lock mechanism
- slim and wide designs
- screwable and snapable versions, extractors with locking pin fixing
- special designs upon request



Mounting material for semiconductors

- mounting disc for discrete devices such as transistors, capacitors and LEDs
- electrically insulating mounting of the transistors
- simple and fast assembly
- insulating clamping pins for various semiconductors for increasing the dielectric strength
- cover and insulating cap for transistors



Mounting material for mechanical components

- distance bolts made of metal and plastics with inner or outer thread
- clamp mounting made of aluminium and plastics for mounting the heatsinks and cases on the mounting rail acc. to DIN EN 50022
- anti-vibration device for minimizing the noise and resonance

Silicon-rubber insulating material for semiconductors

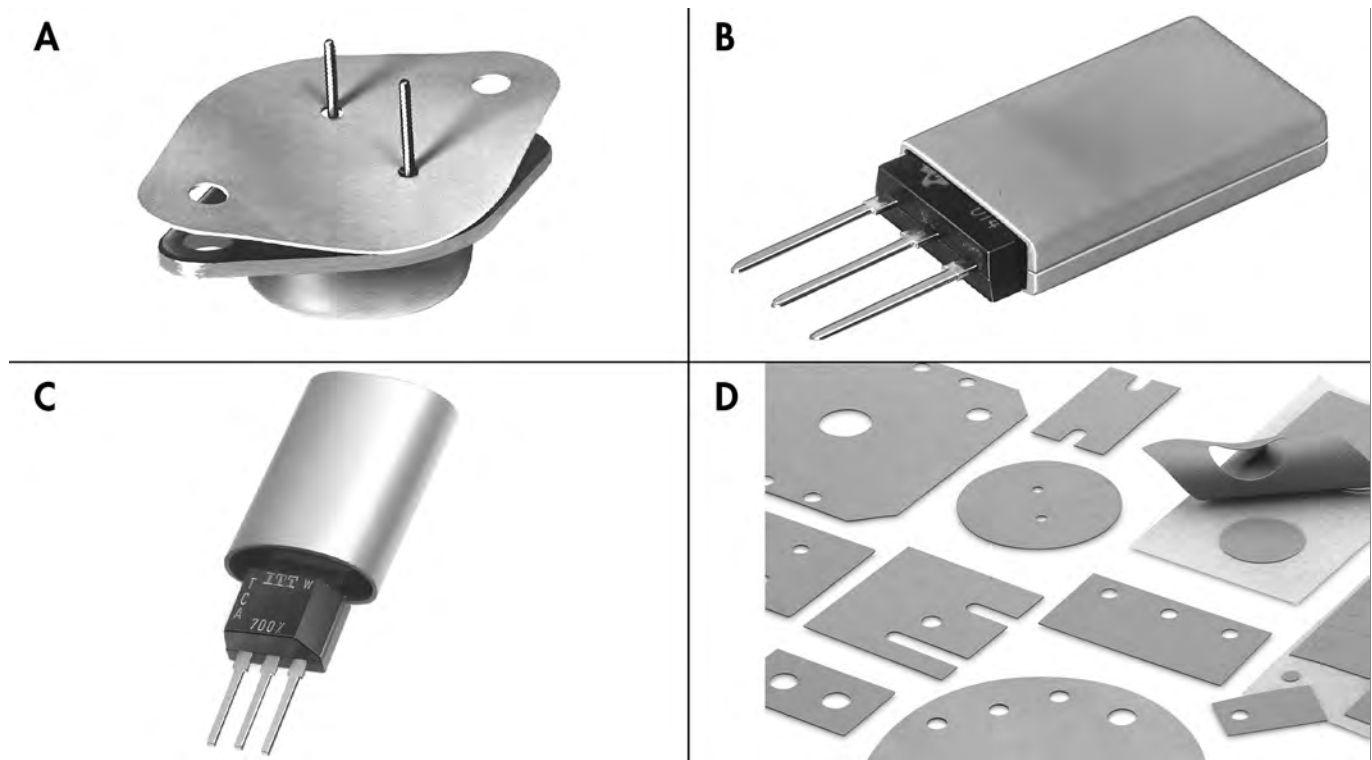

- A:** washer
- B:** insulating cap
- C:** insulating tube
- D:** cuts

Our thermal conduction wafers effect following advantages:

- good surface contact as material is flexible
- reduced production costs as a matter of mounting without thermal conducting paste (clean and fast)
- spring-back of the elastic material protects the transistor against damage
- free of any toxic substances

Customer specific versions:

- punching and cuts of our thermal conductive foil according to drawing
- sold per sheet or by the meter
- other foils, plastics, papers, etc. upon request

The thermal details refer to an area of 1 inch² (6.45 cm²).

Thermal conductive foil	→ E 7 - 10	Heatsinks for PCB	→ A 89 - 112
GEL thermal conductive foils	→ E 12 - 15	Heatsinks for BGA	→ B 17 - 20
Thermal conductive paste	→ E 21 - 22	Extruded heatsinks	→ A 22 - 83
Thermal conductive glue	→ E 23 - 24	Technical introduction	→ A 2 - 8

– other cuttings on request

<p>TO 3</p>	<p>TO 3 M</p>		<p>TO 3/4</p>	
<p>TOP 3</p>	<p>TOP 3/1</p>	<p>TOP 3 PF</p>	<p>TO 218 Multiwatt</p>	
<p>TO 220</p>	<p>TO 247</p>	<p>TO 247/1</p>	<p>TO 3158</p>	
<p>4 x TO220</p>		<p>TO 126</p>	<p>SOT 32</p>	<p>TO 3159</p>

Thermally conductive foil made of siliconelastomer

foil type	foil WS	foil WG	foil WK	foil WB
material	silicone foil, standard	silicone foil, GF reinforced	silicone foil, GF reinforced, one-sided self-adhesive	silicone foil, GF reinforced
Washer				
TO-3	WS 3	WG 3	WK 3	WB 3
TO-3 M	WS 3 M			
TO-3/4	WS 3/4		WK 3/4	
TO-3 PF	WS 3 P	WG 3 P	WK 3 P	WB 3 P
3158	WS 3158		WK 3158	WB 3158
TOP 3	WS TOP 3			
TOP 3/1	WS TOP 3/1		WK TOP 3/1	
TO 218 (Multiwatt)		WG 218		
TO 247	WS 247		WK 247	
TO 220	WS 220	WG 220	WK 220	WB 220
4 X TO 220	WS 4 220			
3159	WS 3159		WK 3159	WB 3159
TO 126			WK 126	
SOT 32			WK 32	
TO 247/1	WS 247/1			
Insulating tube				
TO-220 Ø 11 mm, length 25 mm	WSC-220			
TO-3 PF Ø 13.5 mm, length 25 mm	WSC-3 P			
TO-247 Ø 14.5 mm, length 30 mm	WSC-247			
Insulating tube as meterpiece				
TO-220 Ø 11 mm	WSM-220			
TO-3 PF Ø 13.5 mm	WSM-3 P			
Tape material (width)				
24 mm			WKT 24	
30 mm	WST 30			WBT 30
36 mm	WST 36			
85 mm	WST 85			
300 mm		WGT 300	WKT 300	WBT 300
	Foil WS	Foil WG	Foil WK	Foil WB
material thickness	0.3 mm	0.2 mm		0.15 mm
material hardness	75 Shore A	87 Shore A		90 Shore A
dielectric strength	10 kV	6.5 kV		3 kV
thermal resistance	0.4 K/W	0.42 K/W	0.45 K/W	0.34 K/W
thermal conductivity	1.22 W/m·K	1.13 W/m·K	0.92 W/m·K	1.43 W/m·K
insulation resistance	2.9·10 ¹⁵ Ω·cm	5.7·10 ¹⁵ Ω·cm		1.6·10 ¹⁵ Ω·cm
extensibility	100 %	2 %		4 %
temperature range	-60°C... +180°C			
class of flammability	UL 94 V-0			

Insulating cap

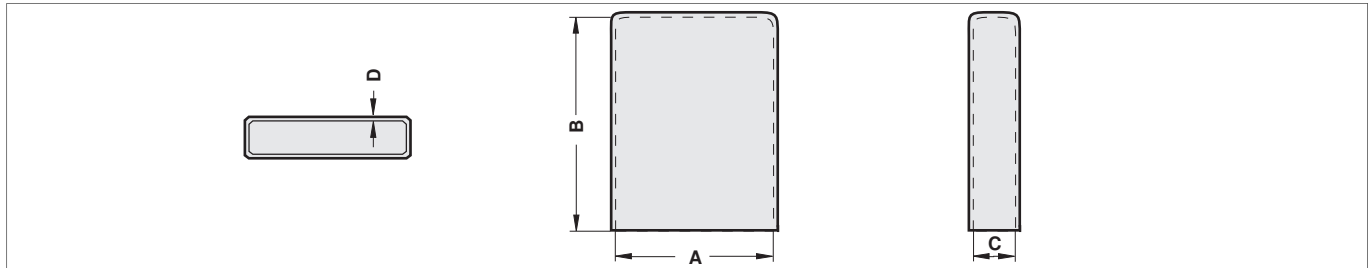

art. no.	type	dim. [mm]			
		A	B	C	D
WSI 220 210	TO 220	11	21.0	5.0	0.9
WSI 220 225	TO 220	11	22.5	5.0	0.3
WSI TOP 3 235	TOP 3	18	23.5	5.0	0.9
WSI TOP 3 280	TO 3 PL/TO 247	16	28.0	5.0	0.3
WSI TO 3 PL	TO 3 PL/TO 247	22	34.0	5.5	0.9

	Foil WSI	Foil WSI
material thickness	0.9 mm	0.3 mm
material hardness	75 Shore A	
dielectric strength	15 kV	10 kV
thermal resistance	0.96 K/W	0.4 K/W
thermal conductivity	1.22 W/m·K	
insulation resistance	2.9·10 ¹⁵ Ω·cm	
extensibility	100 %	
temperature range	-60°C... +180°C	
class of flammability	UL 94 V-0	

Thermal conductive foil
 GEL thermal conductive foils
 Thermal conductive paste
 Thermal conductive glue

→ E 7 – 10
 → E 12 – 15
 → E 21 – 22
 → E 23 – 24

Heatsinks for PCB
 Heatsinks for BGA
 Extruded heatsinks
 Technical introduction

→ A 89 – 112
 → B 17 – 20
 → A 22 – 83
 → A 2 – 8

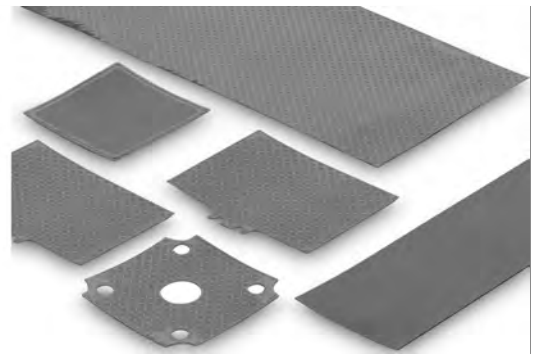
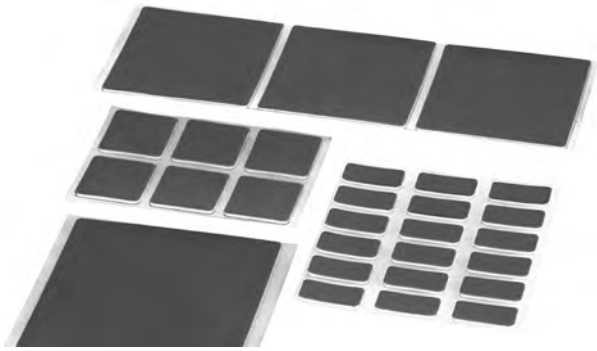
Thermal conductive foil one-sided adhesive

- one-sided acrylate adhesive coating, silicone-free carrier material
- good thermal characteristics with high operating temperature
- thin material thickness for optimal thermal resistance
- high dielectric strength, electrically insulating
- cuttings and customised cut-outs acc. to customer specific requirements

art. no.	type of delivery
WLFT 8943	plates, usable area 300x200mm

	WLFT 8943
description	one-sided adhesive, filled Copolymer
overall thickness	0.17 mm
filling material	ceramic
specific thermal resistance	4.7°C cm ² /W
thermal conductivity	0.4 W/m·K
temperature range	-40°C... +150°C
volume resistance	2.5·10 ¹³ Ω/cm
dielectric strength	62,7 kV/mm
peel strength at ambient temperature and 24 h	6 N/cm
class of flammability	UL 94 V-0

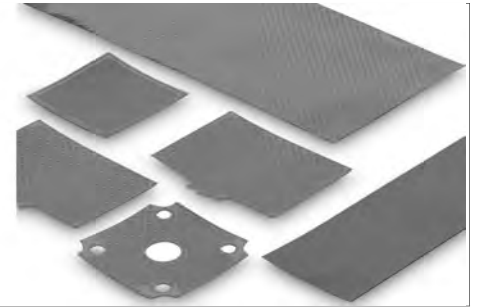
Thermally conductive foil both sides adhesive

- good thermal characteristics
- double-sided adhesive layers
- replaces mechanical fastenings
- cuttings and cut-outs upon request

art. no.	width [mm]	type of delivery	art. no.	width [mm]	type of delivery
WLFT 404 R25	25	sold by the meter	WLFT 414 R100	100	sold by the meter
WLFT 404 R50	50	sold by the meter	WLFT 414 R200	200	sold by the meter
WLFT 404 R100	100	sold by the meter	WLFT 405 R25	25	sold by the meter
WLFT 404 R200	200	sold by the meter	WLFT 405 R50	50	sold by the meter
WLFT 414 R25	25	sold by the meter	WLFT 405 R100	100	sold by the meter
WLFT 414 R50	50	sold by the meter	WLFT 405 R200	200	sold by the meter

art. no.	dimensions [mm]	type of delivery	art. no.	dimensions [mm]	type of delivery
WLFT 404 100x100	100x100	plate	WLFT 414 200x200	200x200	plate
WLFT 404 100x200	100x200	plate	WLFT 405 100x100	100x100	plate
WLFT 404 200x200	200x200	plate	WLFT 405 100x200	100x200	plate
WLFT 414 100x100	100x100	plate	WLFT 405 200x200	200x200	plate
WLFT 414 100x200	100x200	plate			

	WLFT 404	WLFT 414	WLFT 405
description	insulating, double sided adhesive		non insulating, double-sided adhesive
overall thickness	0.127 mm ± 0.03		0.15 mm ± 0.03
truss material	polyimide (Kapton MT) 0.025mm		aluminium foil 0.05mm
glue layer	acrylate (pressure sensitive) double-sided		
thermal conductivity	0.4 W/m·K		0.5 W/m·K
specific thermal resistance	3.7°C cm ² /W		3.4°C cm ² /W
temperature range	-30°C... +125°C		
holding force (overlapping)	0.86 MPa		0.93 MPa
holding force (shear rate)	Al 25°C 0.897 [MPa]/ Al 150°C 0.345 [MPa]/ Cu 25°C 0.828 [MPa]/ Cu 150°C 0.31 [MPa]/ Al₂O₃ 25°C 1.17 [MPa]/ Al₂O₃ 150°C 0.34 [MPa]	Al 25°C 0.897 [MPa]/ Al 150°C 0.345 [MPa]	Al 25°C 0.86 [MPa]/ Al 150°C 0.38 [MPa]/ Cu 25°C 1.1 [MPa]/ Cu 150°C 0.48 [MPa]/ Al₂O₃ 25°C 1.0 [MPa]/ Al₂O₃ 150°C 0.41 [MPa]
dielectric strength	5 kV (AC)		
class of flammability	UL 94 V-0		

E 7
Thermal conductive material
Heatsinks for PCB
Profiles for PCB mounting
Heatsinks for transistors

 → **E 2 - 5**
 → **A 89 - 93**
 → **A 89 - 112**
 → **C 4 - 9**
GEL thermal conductive foils
Spacers
Insulating distance sleeves
Technical introduction

 → **E 12 - 15**
 → **E 40**
 → **E 32 - 33**
 → **A 2 - 8**

Thermally conductive foil both sides adhesive

- double sided adhesive layer
- optimal adhesion of different substrates
- very good thermal conductivity, electrical insulating
- easy handling due to double sided protection foil
- optimized surface moistening and excellent impact strength
- cutouts and different punchings according to customer drawing

art. no.	type of delivery
WLFT 8805	plates, usable area 300x200mm
WLFT 8810	plates, usable area 300x200mm
WLFT 8815	plates, usable area 300x200mm
WLFT 8820	plates, usable area 300x200mm
WLFT 8940	plates, usable area 300x200mm

	WLFT 8805	WLFT 8810	WLFT 8815	WLFT 8820	WLFT 8940
description	double sided adhesive, filled acrylic polymer				
overall thickness	0.13 mm	0.25 mm	0.38 mm	0.5 mm	0.19 mm
filling material	ceramic				
protection cover	silicone treated polyester, 37.5 - 50 µm				
thermal conductivity	0.6 W/m·K				0.9 W/m·K
specific thermal resistance	3.1°C cm ² /W	5.7°C cm ² /W	7.6°C cm ² /W	9.7°C cm ² /W	
temperature range	permanent up to 100°C				permanent up to 150°C
volume resistance	5.2·10 ¹¹ Ω/cm	3.9·10 ¹¹ Ω/cm	3.8·10 ¹¹ Ω/cm		2.5·10 ¹³ Ω/cm
dielectric strength	37 kV/mm				55 kV/mm
peel strength at ambient temperature and 72 h	5.8 N/cm	8.3 N/cm	9.8 N/cm	11.9 N/cm	6 N/cm
class of flammability	UL 746 C				UL 94 V-0

High thermoconducting graphite foils

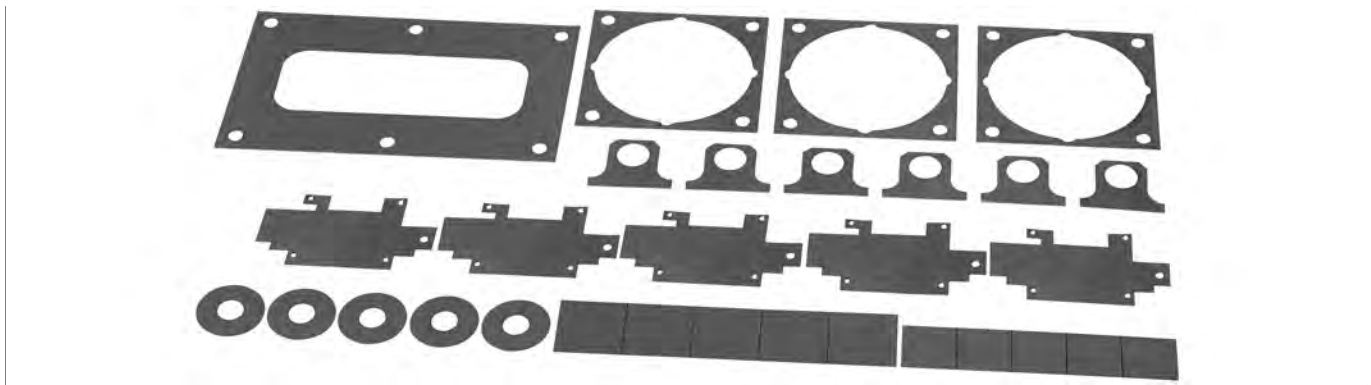

- high-compressed anisotropic natural graphite
- very good thermal characteristics
- optimal for heat spreading
- high operating temperature range
- different material thicknesses and coatings upon request
- customer specified cuttings and stampings acc. to drawing

art. no.	width [mm]	type of delivery	art. no.	width [mm]	type of delivery
WLFG 9010 R 25	25	sold by the meter	WLFG 9020 R 25	25	sold by the meter
WLFG 9010 R 50	50	sold by the meter	WLFG 9020 R 50	50	sold by the meter
WLFG 9010 R 100	100	sold by the meter	WLFG 9020 R 100	100	sold by the meter
WLFG 9015 R 25	25	sold by the meter	WLFG S 900 K R 25	25	sold by the meter
WLFG 9015 R 50	50	sold by the meter	WLFG S 900 K R 50	50	sold by the meter
WLFG 9015 R 100	100	sold by the meter	WLFG S 900 K R 100	100	sold by the meter

	WLFG 9010	WLFG 9015	WLFG 9020	WLFG S 900 K
description	base film made of graphite, electrically conductive	graphite foil, electrically conductive		
version		adherent layer on one side		
overall thickness	0.15 mm	0.2 mm	0.25 mm	0.175 mm
thermal resistance	0,09 K/W	0,07 K/W	0,23 K/W	0,08 K/W
thermal conductivity z (x/y)	5.5 (55) W/m·K	6 (55) W/m·K	4 (55) W/m·K	7.5 (<450) W/m·K
specific thermal resistance	36°C mm ² /W	28.8°C mm ² /W	72°C mm ² /W	34°C mm ² /W
temperature range	-40°C... +500°C			
hardness range	30 Shore D			
tensile strength	5.5 N/mm ²	6 N/mm ²	5.5 N/mm ²	10 N/mm ²
elongation at break	10 %			5 %
tightness	1 g/cm ³			<1.6 g/cm ³
class of flammability	UL 94 V-0			

Heat conductive silicon foam foil

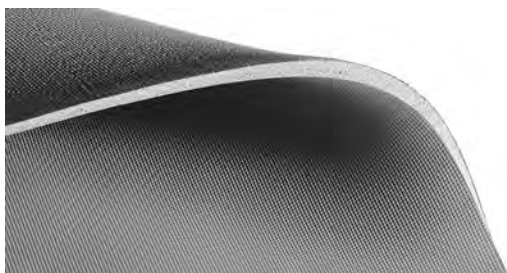

- elastomer foam with closed cell structure
- good heat conductor e.g. between components, heatsinks and casing parts
- electrical insulating
- can be compressed even with a low contact pressure
- absorbs shocks and vibrations

art. no.	material thickness [mm]
WSF 16	1.60 ±0.4
WSF 32	3.20 ±0.8
WSF 635	6.35 ±1.2
WSFS 635	6.35 ±1.2

Thermal resistance at 3.2 mm material thickness:

compression %	contact	10	25	50
contact pressure PSI	>1	5	12	34
R _{th} K/W (1 in ² x 3.2 mm)	6	4.5	2.5	1
heat conductivity W/mK	0.3	0.4	0.45	0.65

- **WSFS 635** double sided adhesive and **WSF** adhesive upon request
- according to NASA gas emission requirements

	WSF	WSFS 635
version	no adhesive	one-sided self-adhesive
thermal conductivity	0.108 W/m·K (substrate)	
hardness range	13 Shore D	
compression, 25%	18 PSI	
temperature range	-62°C... +205°C	
extensibility	150 %	
tensile strength	120 PSI	
dielectric strength	4 kV/mm	
tightness	1.118 g/cm ³	
class of flammability	UL 94 V-1 (at thickness ≥3.2mm)	
type of delivery	plates 914x914mm/ cuttings on customer's requirements	

Silicone free thermal adhesive foils

- silicone free gap-filler with good thermal characteristics
- smooth, compressible and elastic
- cut outs, punchings and modifications according to customer specification
- other material thicknesses upon request

art. no.	material thickness [mm]	R _{th} (100 kPa) [°C in ² /W]	R _{th} (100 kPa) [°C cm ² /W]	art. no.	material thickness [mm]	R _{th} (100 kPa) [°C in ² /W]	R _{th} (100 kPa) [°C cm ² /W]
GEL F 15 10	1.0 ±0.2	1.06	6.56	GEL F 15 G 10	1.0 ±0.2	1.16	7.55
GEL F 15 15	1.5 ±0.2	1.44	8.01	GEL F 15 G 15	1.5 ±0.2	1.52	9.22
GEL F 15 20	2.0 ±0.3	1.83	11.26	GEL F 15 G 20	2.0 ±0.3	1.93	10.89

	GEL F 15	GEL F 15 G
version	standard	polyamide film mesh reinforced
thermal conductivity	1.5 W/m·K	
volume resistance	2 · 10 ³ MΩ/m	
hardness range	53 Shore 00	
temperature range	-40°C... +105°C	
extensibility	150 %	
dielectric constant	9,12 [50 Hz] / 8,55 [1 kHz] / 5,83 [1 MHz]	
dielectric loss factor	0,152 [50 Hz] / 0,135 [1 kHz] / 0,034 [1 MHz]	
dielectric strength	11 kV/mm	
tightness	2.1 g/cm ³	
class of flammability	UL 94 V-0	
type of delivery	on both sides covered with protective foil/ plates, usable area 300x200mm/ cuttings on customer's requirements	

E 11
Thermal conductive material
Thermal conductive foil
Thermal conductive paste
Thermal conductive glue

→ E 2 – 5
→ E 7 – 15
→ E 21 – 22
→ E 23 – 24

Extruded heatsinks
Heatsinks for LEDs
Heatsink profile-overview
Technical introduction

→ A 22 – 83
→ B 35 – 48
→ A 13 – 17
→ A 2 – 8

Gel thermal conducting foils



- highly heat-conductive silocon foil
- smooth, elastic and compressible
- equals uneven surfaces very well (Gap-Filler)

art. no.	material thickness [mm]	R _{th} (100 kPa) [°C in ² /W]	R _{th} (100 kPa) [°C cm ² /W]	art. no.	material thickness [mm]	R _{th} (100 kPa) [°C in ² /W]	R _{th} (100 kPa) [°C cm ² /W]
GEL 05	0.5 ±0.1	0.69	4.45	GEL G 05	0.5 ±0.1	0.63	4.04
GEL 10	1.0 ±0.2	1.03	6.64	GEL G 1	1.0 ±0.2	1.17	7.56
GEL 15	1.5 ±0.2	1.39	8.96	GEL G 15	1.5 ±0.2	1.59	10.27
GEL 20	2.0 ±0.3	1.52	9.78	GEL G 2	2.0 ±0.3	2.07	13.33
GEL 25	2.5 ±0.3	2.10	13.58	GEL G 25	2.5 ±0.3	2.61	16.81
GEL 30	3.0 ±0.3	2.35	15.15	GEL G 3	3.0 ±0.3	2.89	18.66
GEL 35	3.5 ±0.3	2.56	16.51	GEL G 35	3.5 ±0.3	3.35	21.63
GEL 40	4.0 ±0.4	3.25	20.95	GEL G 4	4.0 ±0.4	3.56	22.96
GEL 45	4.5 ±0.4	3.38	21.82	GEL G 45	4.5 ±0.4	3.89	25.10
GEL 50	5.0 ±0.5	3.52	22.70	GEL G 5	5.0 ±0.5	4.22	27.23

	GEL	GEL G 05 - 25	GEL G 3 - 5
version	standard	polyamide film mesh reinforced, adherent layer on one side	
thermal conductivity	1.5 W/m·K		
volume resistance	1·10 ⁶ MΩ/m		
hardness range	49 Shore 00		
temperature range	-60°C ... +200°C		
extensibility	100 %	60 %	
dielectric constant	5.8 [50 Hz]/ 5.6 [1 KHz]/ 5.5 [1 MHz]		
dielectric loss factor	0.048 [50 Hz]/ 0.015 [1 KHz]/ 0.003 [1 MHz]		
dielectric strength	14 kV/mm (AC)	8 kV/mm (AC)	
tightness	2.6 g/cm ³		
class of flammibility	UL 94 V-0	UL 94 V-1	UL 94 V-0
type of delivery	on both sides covered with protective foil/ plates, usable area 300x200mm/ cuttings on customer's requirements		

Thermal conductive material
Thermal conductive foil
Thermal conductive paste
Thermal conductive glue

→ **E 2 - 5**
 → **E 7 - 15**
 → **E 21 - 22**
 → **E 23 - 24**

Extruded heatsinks
Heatsinks for LEDs
Heatsink profile-overview
Technical introduction

→ **A 22 - 83**
 → **B 35 - 48**
 → **A 13 - 17**
 → **A 2 - 8**

Gel thermal conducting foils

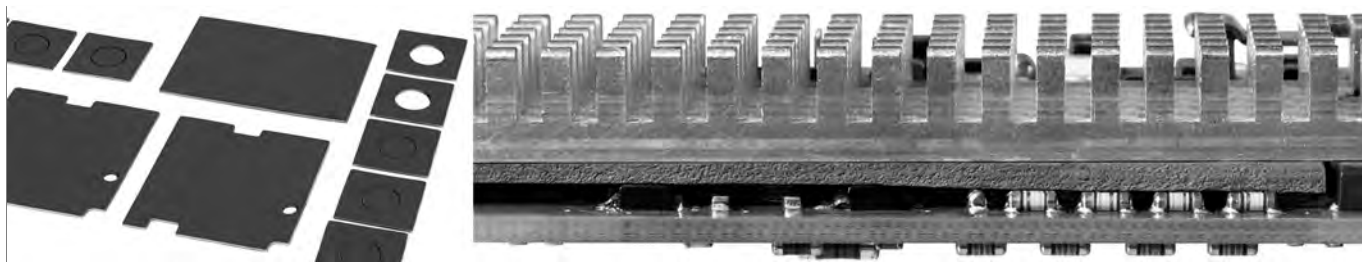

- GEL thermal conductive foils with very good thermal characteristics
- for balancing non-planarities and differences in components (Gap Filler)
- soft, elastic and compressible
- customer specific cuts and punchings according to drawing

art. no.	material thickness [mm]	R _{th} (100 kPa) [°C in ² /W]	R _{th} (100 kPa) [°C cm ² /W]	art. no.	material thickness [mm]	R _{th} (100 kPa) [°C in ² /W]	R _{th} (100 kPa) [°C cm ² /W]
GEL 28 05	0.5 ±0.15	0.23	1.48	GEL 28 G 05	0.5 ±0.15	0.29	1.85
GEL 28 10	1.0 ±0.2	0.44	2.76	GEL 28 G 10	1.0 ±0.2	0.47	2.99
GEL 28 15	1.5 ±0.2	0.61	3.82	GEL 28 G 15	1.5 ±0.2	0.72	4.53
GEL 28 20	2.0 ±0.3	0.80	5.00	GEL 28 G 20	2.0 ±0.3	0.97	6.07
GEL 28 25	2.5 ±0.3	0.90	5.65	GEL 28 G 25	2.5 ±0.3	1.15	7.23
GEL 28 30	3.0 ±0.3	1.10	6.90	GEL 28 G 30	3.0 ±0.3	1.23	7.69
GEL 28 35	3.5 ±0.3	1.27	7.97	GEL 28 G 35	3.5 ±0.3	1.35	8.46
GEL 28 40	4.0 ±0.3	1.39	8.69	GEL 28 G 40	4.0 ±0.3	1.67	10.47
GEL 28 50	5.0 ±0.3	1.67	10.47	GEL 28 G 50	5.0 ±0.3	1.92	12.02

	GEL 28	GEL 28 G
version	standard	polyamide film mesh reinforced
thermal conductivity	2.5 W/m·K	
volume resistance	3.6·10 ⁴ MΩ/m	
hardness range	50 Shore 00	55 Shore 00
temperature range	-60°C ... +200°C	
extensibility	64 %	32 %
dielectric constant	8,98 [50 Hz] / 8,63 [1 kHz] / 8,05 [1 MHz]	
dielectric loss factor	0.0826 [50 Hz]/0.0300 [1 kHz]/0.0052 [1 MHz]	
dielectric strength	15 kV/mm	
tightness	2.7 g/cm ³	
class of flammability	UL 94 V-0	
type of delivery	on both sides covered with protective foil/ plates, usable area 300x200mm/ other dimensions upon request	

E 13

Thermal conductive material
Thermal conductive foil
Thermal conductive paste
Thermal conductive glue

→ **E 2 - 5**
 → **E 7 - 15**
 → **E 21 - 22**
 → **E 23 - 24**

Extruded heatsinks
Heatsinks for LEDs
Heatsink profile-overview
Technical introduction

→ **A 22 - 83**
 → **B 35 - 48**
 → **A 13 - 17**
 → **A 2 - 8**

Thermal adhesive foils

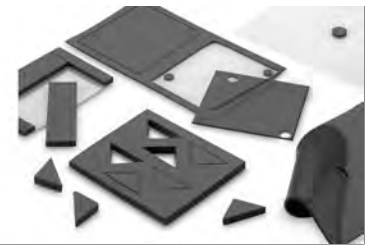
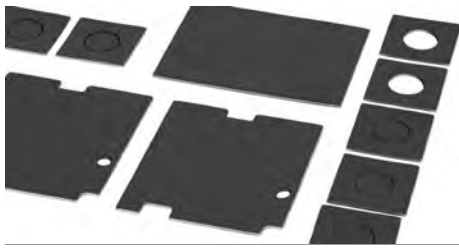

- gap filler with exceptionally good thermal conductivity and low outgassing
- especially smooth, compressible and elastic
- cut outs, punchings and modifications according to customer specification
- other material thicknesses upon request

art. no.	material thickness [mm]	R _{th} (100 kPa) [°C in ² /W]	R _{th} (100 kPa) [°C cm ² /W]	art. no.	material thickness [mm]	R _{th} (100 kPa) [°C in ² /W]	R _{th} (100 kPa) [°C cm ² /W]
GEL 45 05	0.5 ±0.15	0.61	3.94	GEL 45 G 05	0.5 ±0.15	0.64	4.17
GEL 45 10	1.0 ±0.2	0.96	6.27	GEL 45 G 10	1.0 ±0.2	0.97	6.28
GEL 45 15	1.5 ±0.2	1.30	8.42	GEL 45 G 15	1.5 ±0.2	1.71	11.06
GEL 45 20	2.0 ±0.3	1.52	9.85	GEL 45 G 20	2.0 ±0.3	1.71	11.06
GEL 45 25	2.5 ±0.3	1.71	11.08	GEL 45 G 25	2.5 ±0.3	2.03	13.11
GEL 45 30	3.0 ±0.3	1.94	12.52	GEL 45 G 30	3.0 ±0.3	2.28	14.76
GEL 45 35	3.5 ±0.35	2.20	14.20	GEL 45 G 35	3.5 ±0.35	2.54	16.40
GEL 45 40	4.0 ±0.4	2.46	15.88	GEL 45 G 40	4.0 ±0.4	2.80	18.12
GEL 45 45	4.5 ±0.45	2.68	17.34	GEL 45 G 45	4.5 ±0.45	3.03	19.56
GEL 45 50	5.0 ±0.5	2.84	17.34	GEL 45 G 50	5.0 ±0.5	3.22	20.82

	GEL 45	GEL 45 G
version	standard	polyamide film mesh reinforced
thermal conductivity	4.5 W/m·K	
volume resistance	1.4·10 ⁵ Ω/cm	
hardness range	45 Shore 00	
temperature range	-60°C ... +200°C	
extensibility	50 %	
dielectric constant	8,98 [50 Hz] / 8,63 [1 kHz] / 8,05 [1 MHz]	
dielectric loss factor	0,0249 [50 Hz] / 0,0219 [1 kHz] / 0,00675 [1 MHz]	
dielectric strength	11 kV/mm	
tightness	3.2 g/cm ³	
class of flammability	UL 94 V-0	
type of delivery	on both sides covered with protective foil/ plates, usable area 300x200mm/ cuttings on customer's requirements	

Thermal conductive material
Thermal conductive foil
Thermal conductive paste
Thermal conductive glue

→ **E 2 – 5**
 → **E 7 – 15**
 → **E 21 – 22**
 → **E 23 – 24**

Extruded heatsinks
Heatsinks for LEDs
Heatsink profile-overview
Technical introduction

→ **A 22 – 83**
 → **B 35 – 48**
 → **A 13 – 17**
 → **A 2 – 8**

Gel thermal conducting foils

- GEL silicone foils with especially high thermal conductivity
- balances non-planarities and differences in components (Gap Filler)
- soft, elastic and compressible
- cuts, punchings and special designs according to customer specifications

art. no.	material thickness [mm]	R _{th} (100 kPa) [°C in ² /W]	R _{th} (100 kPa) [°C cm ² /W]	art. no.	material thickness [mm]	R _{th} (100 kPa) [°C in ² /W]	R _{th} (100 kPa) [°C cm ² /W]
GEL 60 05	0.5 ±0.1	0.20	1.30	GEL 60 G 05	0.5 ±0.1	0.21	1.37
GEL 60 10	1.0 ±0.2	0.33	2.11	GEL 60 G 10	1.0 ±0.2	0.31	1.99
GEL 60 15	1.5 ±0.2	0.53	3.45	GEL 60 G 15	1.5 ±0.2	0.48	3.08
GEL 60 20	2.0 ±0.3	0.61	3.91	GEL 60 G 20	2.0 ±0.3	0.62	4.00
GEL 60 25	2.5 ±0.3	0.72	4.67	GEL 60 G 25	2.5 ±0.3	0.77	4.96

	GEL 60	GEL 60 G
version	standard	polyamide film mesh reinforced
thermal conductivity	6 W/m·K	
volume resistance	1·10 ⁶ MΩ/m	
hardness range	52 Shore 00	
temperature range	-60°C ... +200°C	
extensibility	80 %	
dielectric constant	6.4 [50 Hz]/6.4 [1 kHz]/6.4 [1 MHz]	
dielectric loss factor	0.035 [50 Hz]/0.005 [1 kHz]/0.001 [1 MHz]	
dielectric strength	13 kV/mm	
tightness	3.2 g/cm ³	
class of flammability	UL 94 V-0	
type of delivery	on both sides covered with protective foil/ plates, usable area 300x200mm/ other dimensions upon request	

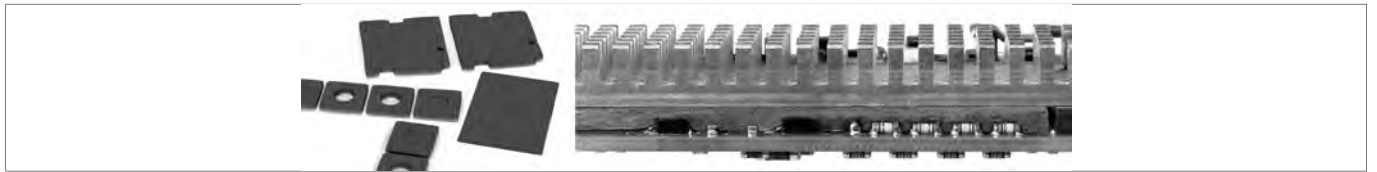

- especially soft design
- levels smallest air gaps and unevennesses
- cuts and contours with cutouts according to customer specification

art. no.	material thickness [mm]	R _{th} (100 kPa) [°C in ² /W]	R _{th} (100 kPa) [°C cm ² /W]	art. no.	material thickness [mm]	R _{th} (100 kPa) [°C in ² /W]	R _{th} (100 kPa) [°C cm ² /W]
GEL 27 S 25	2.5	0.94	6.05	GEL 27 S 50	5.0	1.69	10.91
version:	standard						
thermal conductivity:	2.7 W/m·K						
volume resistance:	2·10 ⁷ MΩ/m						
hardness range:	53 Shore 00						
temperature range:	-60°C ... +200°C						
extensibility:	45 %						
dielectric strength:	15 kV/mm						
tightness:	3 g/cm ³						
class of flammability:	UL 94 V-0						
type of delivery:	on both sides covered with protective foil/ plates, usable area 300x200mm/ other dimensions upon request						

E 15

Thermal conductive material
Thermal conductive foil
Thermal conductive paste
Thermal conductive glue

→ **E 2 - 5**
 → **E 7 - 15**
 → **E 21 - 22**
 → **E 23 - 24**

Extruded heatsinks
Heatsinks for LEDs
Heatsink profile-overview
Technical introduction

→ **A 22 - 83**
 → **B 35 - 48**
 → **A 13 - 17**
 → **A 2 - 8**

Kapton insulator washers

- very low thermal resistance
- optimised heat conductivity
- best mechanical characteristics
- polyimide-carrier foil with silicone-free phase changing thermal conductive layer completely coated on both sides
- clean processing, no abrasion of the coating
- stacked foils do not stick together
- good resistance against cleaning agents
- no cold flow
- low pressure force necessary, thus particularly applicable for spring-fixing of semiconductors
- cuttings and special versions according to customer's requirements
- the thermal details refer to an area of 1 inch² (6.45 cm²)

art. no. KAP 1 P suitable for pre-cut parts (plate)	art. no. KAP 247 O TO 248/ TO 218/ TO 247	art. no. KAP 218 O TO 218	art. no. KAP 220 O TO 220	art. no. KAP 218 TO 248/ TO 218/ TO 247
art. no. KAP 220 G TO 220	art. no. KAP 220 K TO 220	art. no. KAP 3 G TO 3	art. no. KAP 3 K TO 3	

KAP	
material	polyimide-carrier foil with silicone-free phase changing thermal conductive layer completely coated on both sides
material thickness	0.077mm (substrate 0.05mm)
thermal conductivity	0.45 W/m·K (substrate)
insulation resistance	10 ¹⁴ Ω
thermal resistance	0.15 K/W [at 1 inch ² ; = 6.45 cm ² ; = TO 3 (KAP 3)]
temperature range	-40°C... +150°C
phase change temperature	52 °C
extensibility	30 %
dielectric strength	7.8 kV
class of flammability	UL 94 V-0

Profiles for PCB components
Heatsinks for PCB
Profiles for PCB mounting
Heatsinks for transistors

→ A 91
→ A 89 - 93
→ A 89 - 112
→ C 4 - 9

Finger-shaped heatsinks
Distance sleeves for PCB's in HP grid
Spacers
Technical introduction

→ C 2 - 3
→ E 39
→ E 40
→ A 2 - 8

Aluminium oxide wafers

– other thicknesses and versions on request

± = thickness; □ = flatness

art. no. AOS 247 ±1 mm □0.02 mm	art. no. AOS 218 247 ±3 mm □0.15 mm	art. no. AOS 218 247 1 ±1.5 mm □0.02 mm	art. no. AOS 3 P 2 ±1 mm □0.15 mm	art. no. AOS 3 P SL ±1.5 mm □0.15 mm
art. no. AOS 220 3 ±1.6 mm □0.11 mm	art. no. AOS 220 SL ±4.5 mm □0.054 mm	art. no. AOS 220 4 ±1.5 mm □0.054 mm	art. no. AOS 220 ±1.5 mm □0.054 mm	art. no. AOS 32 ±1.5 mm □0.033 mm
art. no. AOS 127 ±3 mm □0.076 mm	art. no. AOS 3 P ±1.5 mm □0.061 mm	art. no. AOS 5 ±1.5 mm □0.032 mm	art. no. AOS 93 ±2.3 mm □0.03 mm	art. no. AOS 18 ±1.5 mm □0.023 mm
art. no. AOS 3 ±2.9 mm □0.123 mm	art. no. AOS 66 ±2.5 mm □0.10 mm			

	AOS
material	Al ₂ O ₃ - ceramics
thermal resistance	0.3 K/W [at 1 inch ² ; = 6.45 cm ² ; = TO 3 (AOS 3 G)]
specific electrical resistance	>10 ¹⁴ Ω/cm
thermal conductivity	25 W/m·K
dielectric constant	9
linear expansion coefficient	~8·10 ⁻⁶ /K
snap through stability	10 kV/mm

Aluminium oxide wafers according to customer's instructions

- laser-cut versions with outer dimensions and cutouts according to customer's requirements
- other plate dimensions upon request
- max. plate dimension 180 x 180 mm

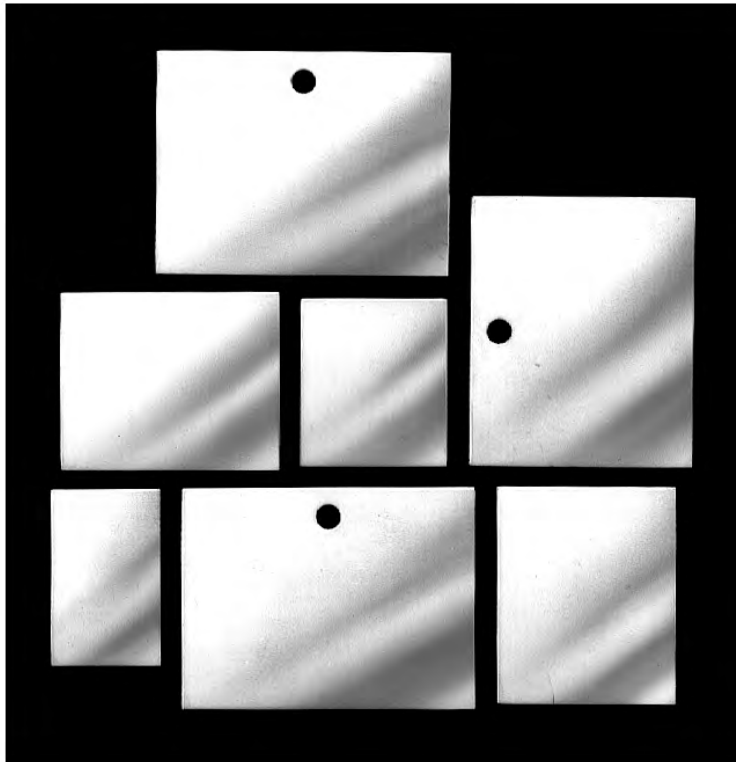

material thickness [mm]	outer dimensions [mm]
2.000	114x114
2.540	114x114
1.500	114x114
1.270	114x114
1.000	114x114/ 165x115/ 160x113
0.800	114x114/ 165x115/ 160x113
0.635	106.5x106.5/ 114x114/ 165x115/ 160x113
0.500	106.5x106.5/ 114x114
0.400	106.5x106.5/ 114x114
0.300	106.5x106.5/ 114x114
0.250	106.5x106.5/ 114x114

Mica wafers

art. no. GS 220 C TO 220	art. no. GS 218 TO 218	art. no. GS 3 P SL TOP 3	art. no. GS 66 P TO 66	art. no. GS 220 4 TO 220
art. no. GS 220 P TO 220	art. no. GS 32 P SOT 32	art. no. GS 3 P TOP 3	art. no. GS 3 TO 3	

	GS
material	muskovit
material thickness	0.05 mm
thermal resistance (GS 3)	0.4 K/W
insulation resistance	$3 \cdot 10^{17} \Omega \cdot \text{cm}$
snap through stability	5 kV

Free standing film

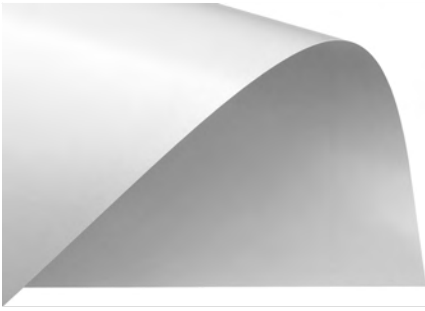

- self-supporting differential phase changing thermal interface material, contains no substrate (Free Standing Film)
- materials with phase change temperature at 52 °C;
- best thermal conductivity, exceeding phase change temperature point, material flows into all gaps between components and heatsink
- thixotropic, does not migrate from the interface area
- no lowering of thermal conductivity though thermal cycling
- application with very low contact pressure, due to non elastomeric material, particularly suitable for clamp mounting of components
- electrically non-conductive, but not an insulator
- self adhering characteristics, also suitable for large areas
- no toxic ingredients
- custom required shapes on request
- all with protection foil on both sides

art. no.	basin	dimensions [mm]
FSF 52 P	plate, protection foil on both sides	330x343x0.127 ±0.025

	FSF 52 P
phase change temperature	52 °C
colour	white
tightness	2 g/cm ³
thermal conductivity	0.9 W/m·K
thermal resistance (1 in², TO 3) at contact pressure of	0.03 K/W 0.031 N/mm ²
temperature range	≤ +200°C
adhesive holding force	0.35 N/mm ²
class of flammability	UL 94 V-0
dielectric constant	3.8 [1 kHz] 3.4 [1 MHz]

Mica wafers

Thermal conductive foil

Thermal conductive paste

Thermal conductive glue

→ E 19

→ E 7 – 10

→ E 21 – 22

→ E 23 – 24

Thermal conductive material

Insulating caps

Aluminium oxide wafers

Technical introduction

→ E 2 – 5

→ E 51

→ E 17 – 18

→ A 2 – 8

E 20

Thermal transfer compounds

Silicon thermal transfer compound

– thermal transfer compound used to reduce the thermal transmission resistance between semiconductor and heatsink



art. no.	basin	delivery quantity [g]
WLP 004	box	4
WLP 035	box	35
WLP 500	box	500
WLP 300 S	cartridge (310 ml)	300
WLP 500 S	cartridge (310 ml)	500

Silicone-free thermal transfer compound

– thermal transfer compound used to reduce the thermal transmission resistance between semiconductor and heatsink



art. no.	basin	delivery quantity [ml]	delivery quantity [g]
WLPF 05	syringe	2	—
WLPF 10	syringe	5	—
WLPF 20	syringe	10	—
WLPF 50	syringe	20	—
WLPF 300 S	cartridge (310 ml)	—	300

	WLP	WLPF
composition	silicone oil, inorganic filling material	silicone free synthetic liquid. Metal oxide filling.
consistence	pasty	
colour	white	white-grey
tightness	1.1 g/cm ³	approx. 2 g/cm ³
thermal conductivity	0.61 W/m·K	>0.7 W/m·K
specific electrical resistance	>10 ¹² Ω/cm	
flashpoint	none (DIN 53213)	of the basic oil >280°C (ISO 2592)
drop point	>260°C	
thermal resistance	no bleeding at (4 h/200°C)	<1% (96 h/200°C)
temperature range	-40°C ... +250°C	-40°C... +150°C
acid number	< 0.01 mg KOH/g	
solubility in water	insoluble	

E 21

Mica wafers
Thermal conductive foil
Thermal conductive paste
Thermal conductive glue

→ E 19
→ E 7 – 10
→ E 21 – 22
→ E 23 – 24

Thermal conductive material
Insulating caps
Aluminium oxide wafers
Technical introduction

→ E 2 – 5
→ E 51
→ E 17 – 18
→ A 2 – 8

Thermal transfer compounds

Ceramic filled, silicone-free thermal conductive paste with high thermal conductivity

- suitable especially for silicone-sensitive applications
- no drying out, hardening or melting of the thermal conductive paste
- high long-term stability
- further package sizes, container types such as cans, cartridge, etc. upon request



art. no.	basin	delivery quantity [ml]
WLPK 3	syringe	3
WLPK 5	syringe	5
WLPK 10	syringe	10

	WLPK
composition	silicone-free, synthetic fluid ceramic filled
consistance	pastey
colour	silver
tightness	1.4 g/cm ³
thermal conductivity	10 W/m·K
dielectric strength	not applicable, because conducting
temperature range	-60°C ... +150°C
solubility in water	insoluble

Thermally conductive adhesive

- thermally conductive, electrically non-conductive adhesive
- two part epoxy resin adhesive, metaloxide filled
- fully replaces mechanical fastenings
- excellent function and application characteristics
- **to be stored at a cool and dark place**

WLK 5



WLK 10



art. no.	composition	art. no.	composition
WLK 5	5 g resin/0.5 g hardener	WLK 10	10 g resin/1 g hardener

WLK 30



WLK 120



art. no.	composition	art. no.	composition
WLK 30	30 g resin/3 g hardener	WLK 120	120 g resin/12 g hardener

	WLK
thermal conductivity	0.836 W/m·K
specific thermal resistance	1.2 m·K/W
volume resistance	10 ¹⁶ Ω/cm
temperature range	-56°C... +149°C
hardening time	20°C approx. 16-24h / 25°C approx. 8 h / 120°C approx. 20 min
glue layer	Epoxid
mixture proportion	10:1

E 23

Thermal conductive material
 Thermal conductive foil
 GEL thermal conductive foils
 Thermal conductive paste

→ E 2 - 5
 → E 7 - 10
 → E 12 - 15
 → E 21 - 22

Thermal conductive glue
 fan cooler for Pentium and MMX
 heatsinks for Pentium III FC PGA
 Technical introduction

→ E 23 - 24
 → B 59
 → B 57
 → A 2 - 8

Thermally conductive adhesive

- solvent-free and thermal conductive two part adhesive
- epoxy based filled with aluminium oxide
- composition of hardener and resin (1:1) with statical mixing tube
- lockability of the container via Luer-Lock System
- good usage and working properties



art. no.	basin	contents of delivery
WLK DK 4	syringe	1x 4 ml syringe / 3x mixer WLK M4
WLK DK 10	syringe	1x 10 ml syringe / 3x mixer WLK M4
WLK DK 50	cartridge	1x 50 ml cartridge / 3x mixer WLK M50

	WLK DK
thermal conductivity	1 W/m·K
specific thermal resistance	118°C cm/W
volume resistance	8·10 ¹¹ Ω/cm
temperature range	-50°C... +145°C
working life at room temperature	approx. 30 min
hardening time	25°C approx. 4 h/50°C approx. 1 h/85°C approx. 10 min/125°C approx. 2 min
glue layer	Epoxid
mixture proportion	1:1

Accessories

- more package sizes and container types upon request
- store cool and dry

art. no.	contents of delivery
WLK M 4	10x mixer für 4 & 10 ml syringe (packing unit 10 pieces)
WLK M 50	10x mixer für 50 ml cartridge (packing unit 10 pieces)
WLK P	1x applicator gun for 50 ml cartridge

Fastening for mounting rail



- universal, solid plastic clip fastening for all 35 mm mounting rails
- suitable for rail material thicknesses from 1 to 2.3 mm according to DIN EN 60 715 (formerly DIN EN 50 022)
- registered design DE 200 07 435.0
- fast and easy mounting of heatsinks, casings etc. due to direct snap up on the mounting rail

- safe hold due to a stable extruded plastic profile with integrated spring back
- electroconductive material or surface on request
- special lengths and treatments on customer's request
- * = examples of mounting rail versions suitable for **KL 35 K**

art. no.	dim. [mm]	art. no.	dim. [mm]	
KL 35 K 40	40	KL 35 K 75	75	
KL 35 K 50	50	KL 35 K 100	100	
material:	rigid PVC			
heat distortion:	-30°C ... +80°C			
colour:	anthracite grey			
class of flammability:	UL 94 V-0			

- safe hold due to a stable extruded profile with integrated stainless steel spring
- special lengths (≥ 40 mm), treatments and surfaces on request
- * = examples of mounting rail versions suitable for KL 35

art. no.	dim. [mm]	art. no.	dim. [mm]	art. no.	dim. [mm]
KL 35 50	50	KL 35 75	75	KL 35 100	100
material:	aluminium				
surface:	clear anodised				

Guide rails

Screw-on type

- for eurocards
- connectors according to DIN 41612 or VG 95324 mountable
- high stability through inner reinforcements
- stable foot mounting through inserted brass- thread inserts
- groove depth: 2.2 mm, groove width 1.9 mm
- suitable for PCB thicknesses from 0.5 to 1.85 mm
- * = printed circuit board

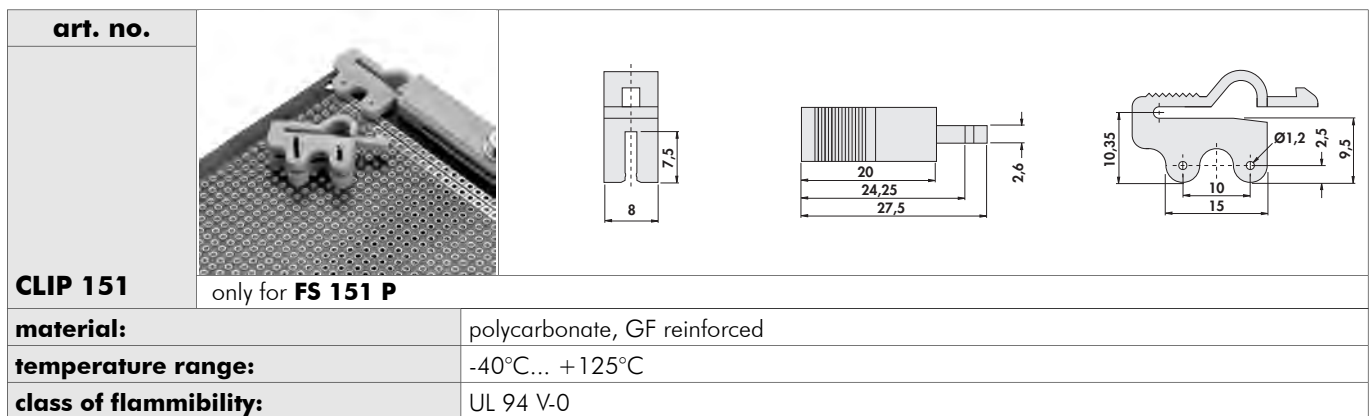
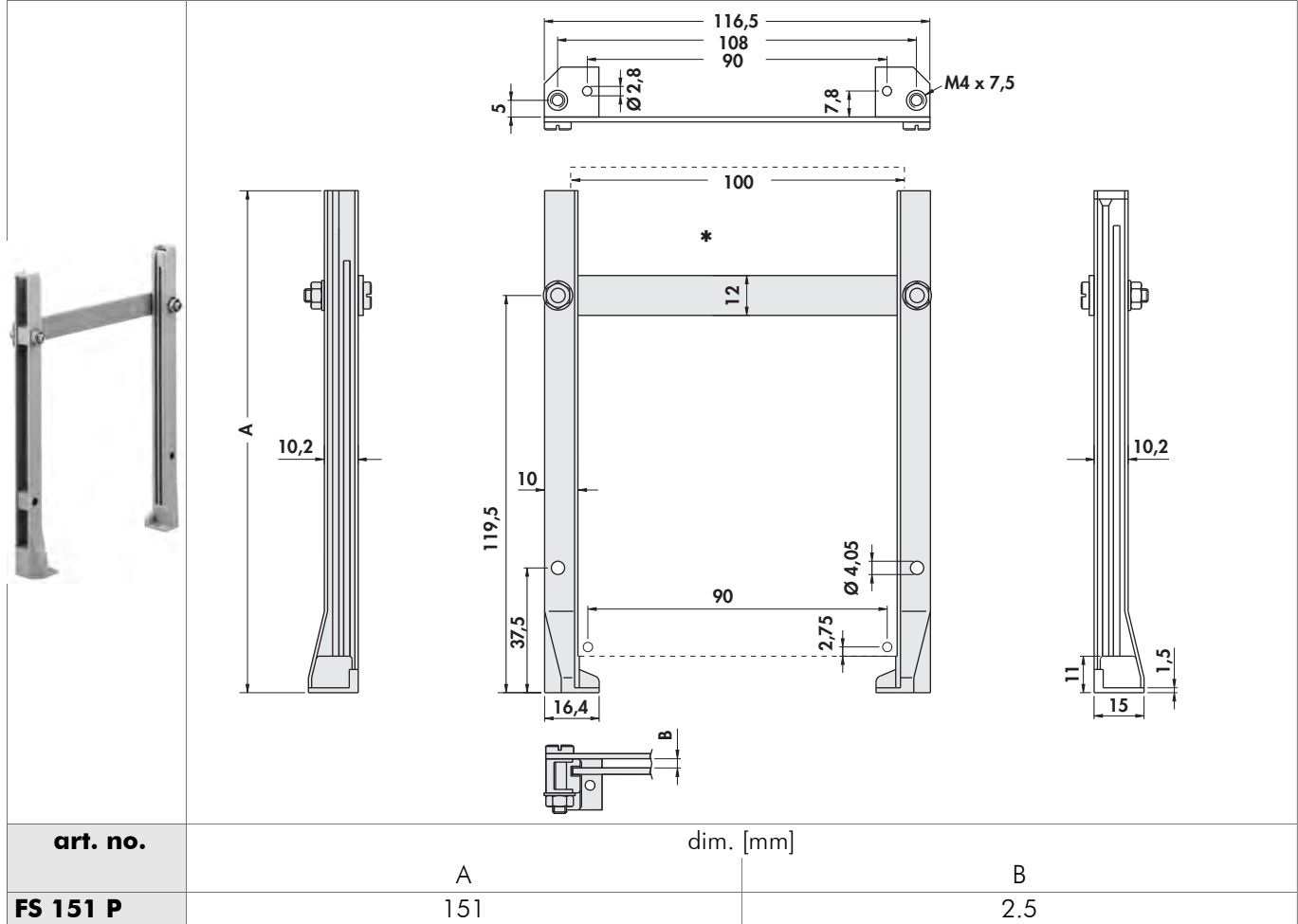

Solder pins
 Snap-in guide rails
 Extractors for guide rails
 Insulating clamping parts





→ E 43
 → E 29 - 30
 → E 30
 → E 45

Distance sleeves for PCB's in HP grid → E 39
 Mounting pads for transistors → E 47
 Vibration dampers → E 41
 Technical introduction → A 2 - 8

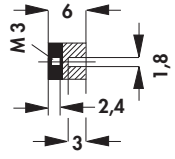
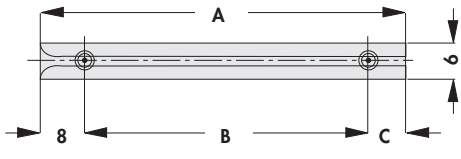
Guide rails

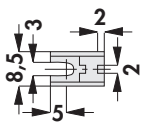
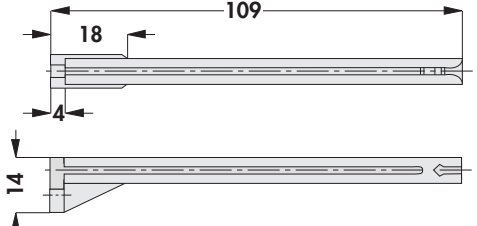
Screw-on type

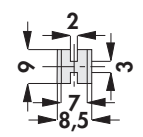
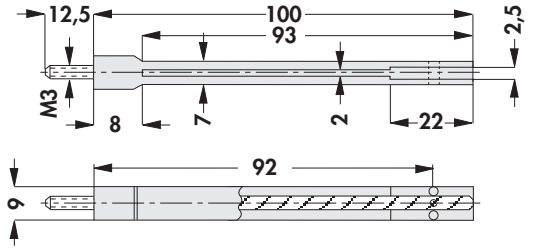
			
art. no.	dim. [mm]		
	A	B	C
FS 6 065	65	50	7
FS 6 070	70	50	12
FS 6 080	80	67	5
FS 6 090	90	67	15
FS 6 100	100	84	8
FS 6 110	110	84	18
FS 6 120	120	84	28
FS 6 130	130	84	38
material:	polycarbonate, GF reinforced		
temperature range:	-20°C... +130°C		
thread nut:	brass nickel-plated		
class of flammability:	UL 94 V-0		

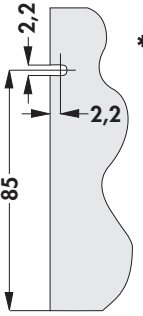
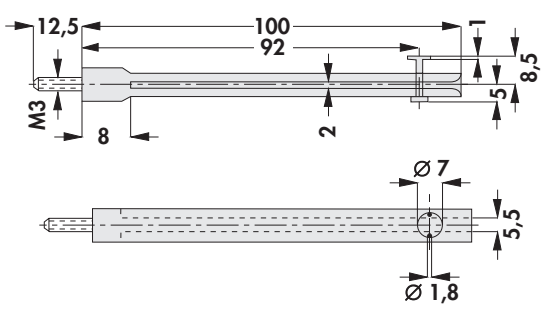
art. no.			
FS 109			
art. no.			
FS 100			
art. no.			
MSVL 100			
	* = position of snap-in slot		
material:	polyamide, GF reinforced		
temperature range:	-40°C... +205°C		
class of flammability:	UL 94 V-0		

Solder pins
Snap-in guide rails
Extractors for guide rails
Insulating clamping parts

→ E 43
→ E 29 – 30
→ E 30
→ E 45

Distance sleeves for PCB's in HP grid → E 39
Mounting pads for transistors → E 47
Vibration dampers → E 41
Technical introduction → A 2 – 8

Guide rails

Lockable mounting rails

- lockable by pushing the plastic pin or the metal button
- no conductive connection to the PCB
- the PCB requires a snap-in slot in accordance to the drawing
- other position with locking device on request
- * = position of snap-in slot

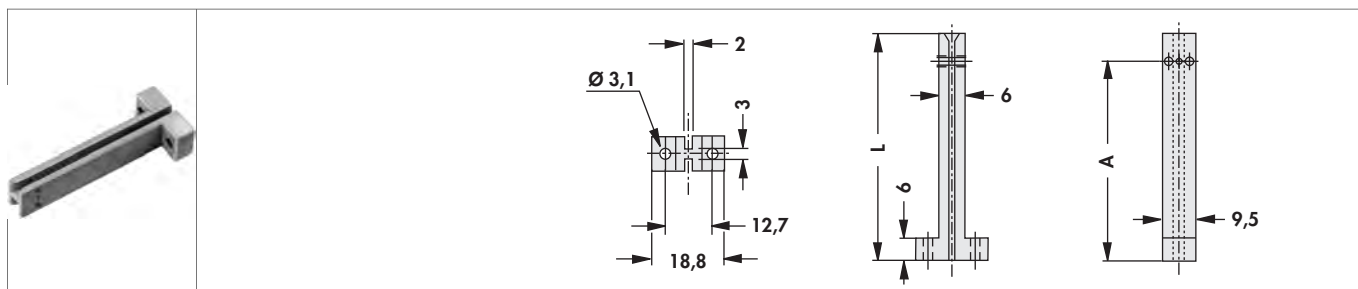

art. no.	version	dim. [mm]		art. no.	version	dim. [mm]	
		L	A			L	A
FS 85 50	without bolting device	50	42	FS 85 70	without bolting device	70	62
FS 85 60	without bolting device	60	52	FS 85	without bolting device	85	76

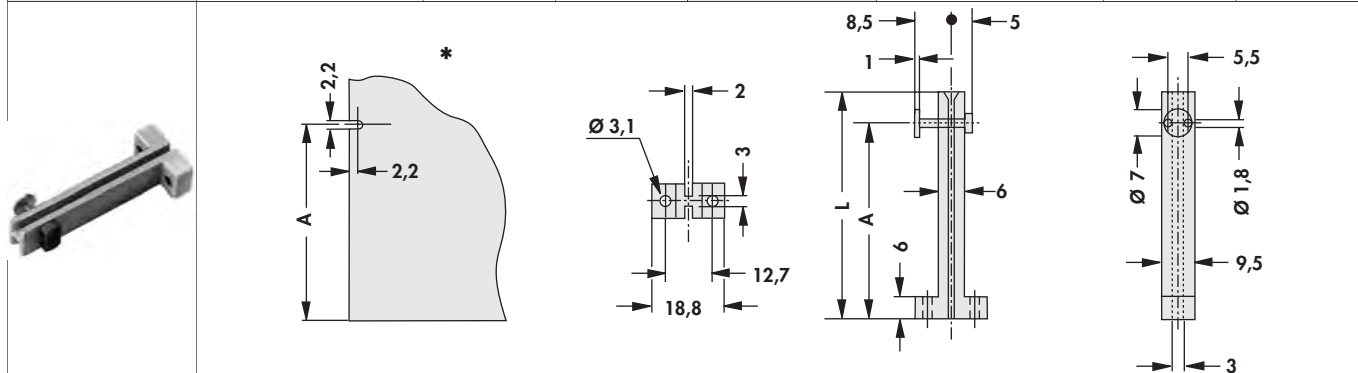

art. no.	version	dim. [mm]		art. no.	version	dim. [mm]	
		L	A			L	A
MSVL 50	with bolting device	50	42	MSVL 70	with bolting device	70	62
MSVL 60	with bolting device	60	52	MSVL 85	with bolting device	85	76

material:	polyamide, GF reinforced
temperature range:	-40°C... +205°C
class of flammability:	UL 94 V-0

- the guide bars have got mounting holes for vertical and horizontal assembly of printed circuits
- they can also be stacked together horizontally or vertically using pins and treatments

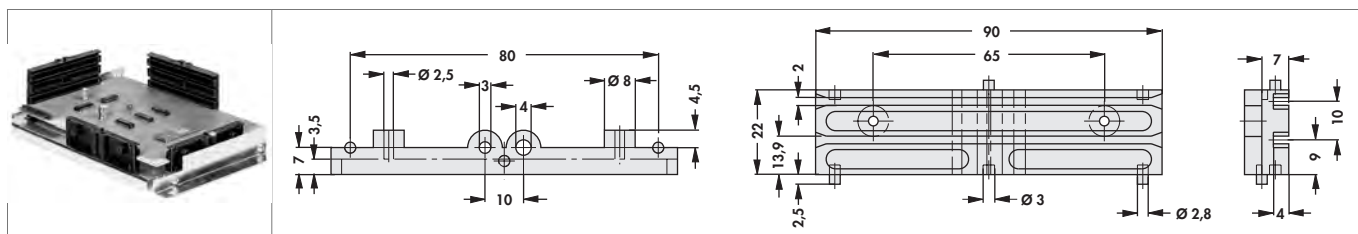

art. no.	
MSHV 90	
material:	polyamide, GF reinforced
class of flammability:	UL 94 V-0

Solder pins
 Snap-in guide rails
 Extractors for guide rails
 Insulating clamping parts

→ E 43
 → E 29 - 30
 → E 30
 → E 45

Distance sleeves for PCB's in HP grid → E 39
 Mounting pads for transistors → E 47
 Vibration dampers → E 41
 Technical introduction → A 2 - 8

Guide rails

Snap-in

– narrow version

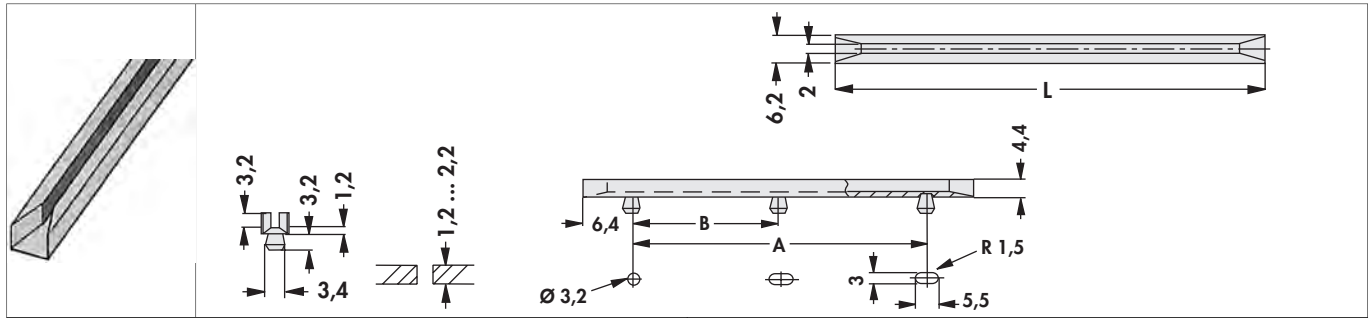

art. no.	dim. [mm]		art. no.	dim. [mm]		
	L	A		L	A	B
FS S 06 2	63.5	50.8	FS S 15 2	152.4	139.7	—
FS S 07 2	76.2	63.5	FS S 16 2	165.1	152.4	—
FS S 08 2	88.9	76.2	FS S 19 3	190.5	177.8	88.9
FS S 10 2	101.6	88.9	FS S 20 3	203.2	190.5	95.2
FS S 11 2	114.3	101.6	FS S 21 2	215.9	203.2	—
FS S 12 2	127.0	114.3	FS S 21 3	215.9	203.2	101.6
FS S 13 2	139.7	127.0				

material:	nylon, natural coloured
temperature range:	-40°C... +120°C
class of flammability:	UL 94 V-2

– wide version

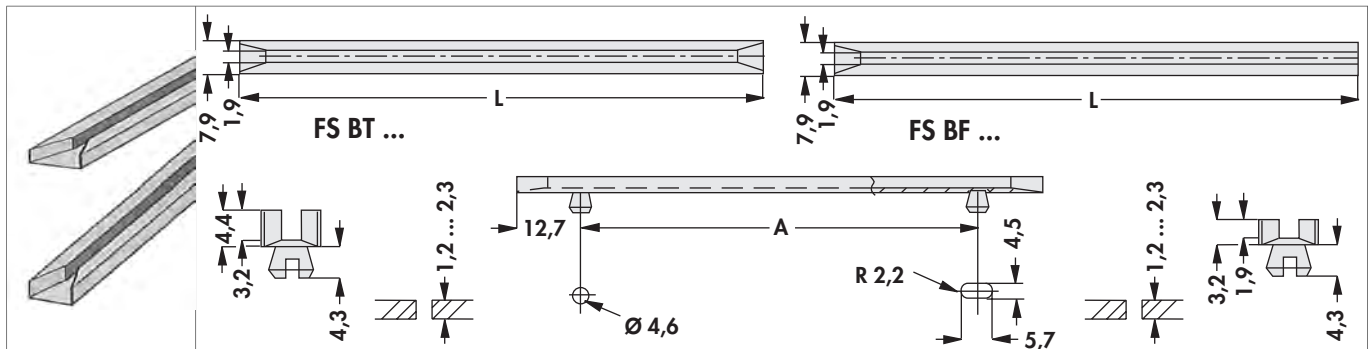

art. no.	version	dim. [mm]		art. no.	version	dim. [mm]	
		L	A			L	A
FS BT 06	deep groove	63.5	38.1	FS BF 06	shallow groove	63.5	38.1
FS BT 08	deep groove	88.9	63.5	FS BF 07	shallow groove	76.2	50.8
FS BT 10	deep groove	101.6	76.2	FS BF 10	shallow groove	101.6	76.2
FS BT 11	deep groove	114.3	88.9	FS BF 11	shallow groove	114.3	88.9
FS BT 13	deep groove	139.7	114.3	FS BF 13	shallow groove	139.7	114.3
FS BT 15	deep groove	152.4	127.0	FS BF 15	shallow groove	152.4	127.0
FS BT 16	deep groove	165.1	139.7	FS BF 19	shallow groove	190.5	165.1
FS BT 19	deep groove	190.5	165.1	FS BF 20	shallow groove	203.2	177.8
FS BT 20	deep groove	203.2	177.8				

material:	nylon, natural coloured
temperature range:	-40°C... +120°C
class of flammability:	UL 94 V-2

Guide rails

Ejectors

- low profile
- suitable for ejectors **art. no. AHG V 14** und **AHG V 17**

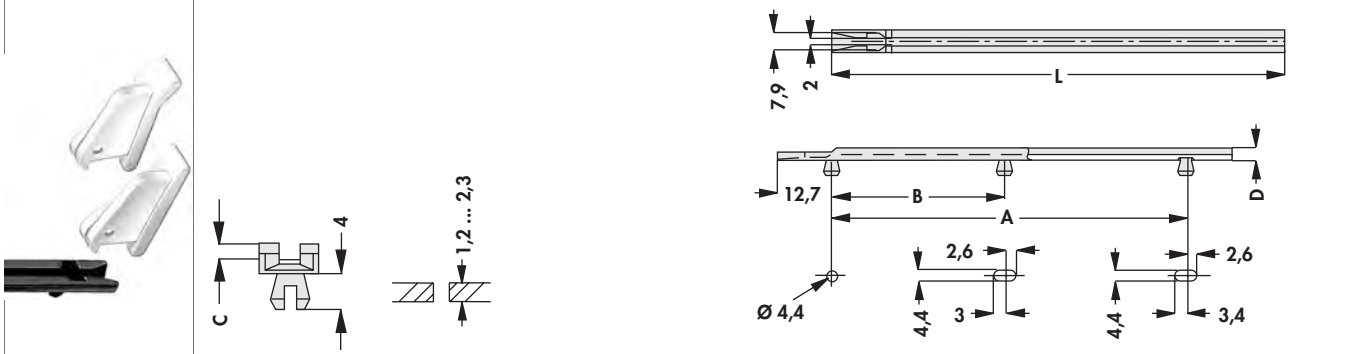

art. no.	dim. [mm]				art. no.	dim. [mm]				
	L	A	C	D		L	A	B	C	D
FS LP 05	50.8	25.8	2.0	3.2	FS LP 15	152.4	127.4	—	2.0	3.2
FS LP 07	76.2	38.5	2.0	3.2	FS LP 16	165.1	127.4	—	2.0	3.2
FS LP 08	88.9	38.5	2.0	3.2	FS LP 17	177.8	153.2	—	2.0	3.2
FS LP 10	101.6	76.6	2.0	3.2	FS LP 22	228.6	191.3	95.7	2.0	3.6
FS LP 11	114.3	76.6	2.0	3.2	FS LP 30	304.8	267.9	134.0	2.4	4.0
FS LP 13	139.7	76.6	2.0	3.2						

material: polyamide, GF reinforced
temperature range: -40°C... +120°C
class of flammability: UL 94 V-0

- deep guideway
- bevelled entrance zone

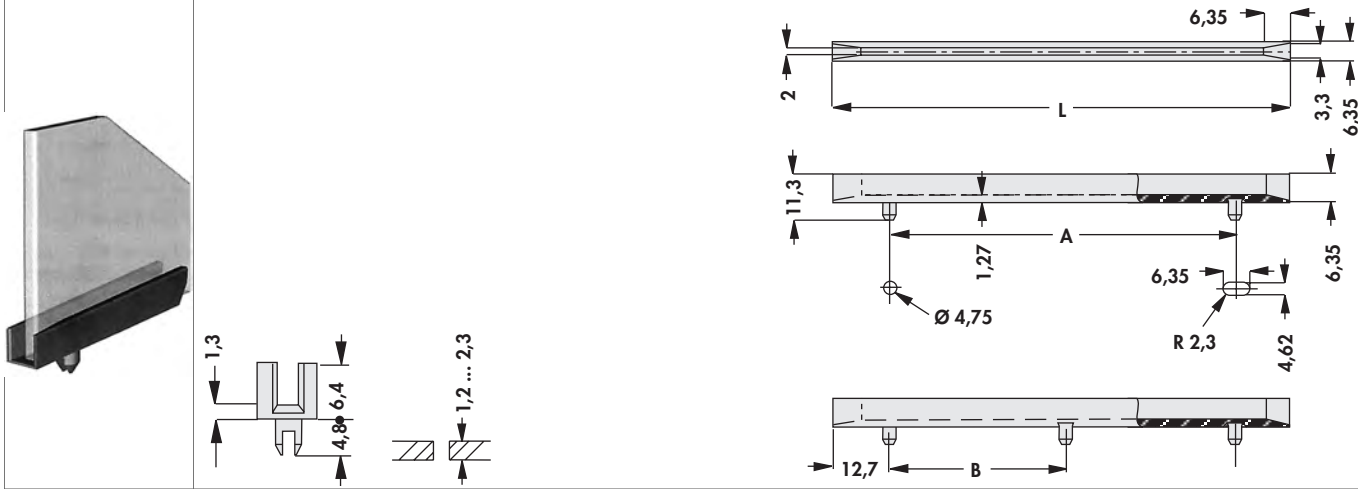

art. no.	dim. [mm]		
	L	A	B
FS U 06	63.5	38.1	—
FS U 11	114.3	88.9	—
FS U 20	203.2	177.8	88.9

material: polyamide, GF reinforced
temperature range: -40°C... +120°C
class of flammability: UL 94 V-0

Solder pins
 Snap-in guide rails
 Extractors for guide rails
 Insulating clamping parts

→ E 43
 → E 29 - 30
 → E 30
 → E 45

Distance sleeves for PCB's in HP grid → E 39
 Mounting pads for transistors → E 47
 Vibration dampers → E 41
 Technical introduction → A 2 - 8

E 30

Ejectors

<p>art. no.</p>	
<p>AHG V 14</p>	<p>* = mounting dimensions; locking in FS LP</p>
<p>art. no.</p>	
<p>AHG V 17</p>	<p>* = mounting dimensions; locking in FS LP</p>
<p>art. no.</p>	
<p>AHG K 27</p>	
<p>art. no.</p>	
<p>AHG K 28</p>	
<p>art. no.</p>	<p>dim. [mm] A</p>
<p>AHG L 7</p>	<p>7.4</p>
<p>material:</p>	<p>nylon</p>
<p>temperature range:</p>	<p>-40°C... +120°C</p>
<p>class of flammability:</p>	<p>UL 94 V-2</p>
<p>type of delivery:</p>	<p>all ejectors with matching spring pin</p>

field of applications:

- insulated assembly of stacked PCB
- insulated assembly of stacked heatsinks with varying capacities
- insulated assembly of chassis plates in cases
- insulated supports in the wiring
- mechanically very stable as threads are made of brass
- other lengths on request
- dimensions = nominal size: deviation ± 0.5 mm
- ... please indicate length "L"

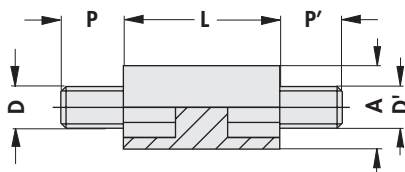

art. no.	dim. [mm]			
	A	D/D'	L	P/P'
ISAB 25 A ...	8.0	M2.5/M2.5	10/ 15/ 20/ 25	6.0
ISAB 3 A ...	8.0	M3/M3	10/ 20	6.0
ISAB 4 A ...	8.0	M4/M4	15/ 20	6.0
ISAB 6 A ...	12.7	M6/M6	25	12.7
dielectric strength:	27 kV/mm			
creeping current resistance:	CTI 600			
thread inserts:	brass			
temperature range:	-30°C... +85°C (short term +200°C)			
surface:	raw			
plastic body:	polyamide 66			
colour:	natural (opaque)			

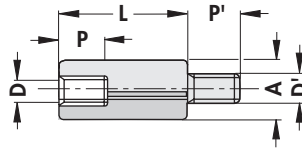
Insulating spacers with internal and external thread

art. no.	dim. [mm]			
	A	D/D'	L	P/P'
ISAB 25 B ...	8.0	M2.5/M2.5	10/ 13/ 15/ 18/ 20/ 25/ 30	6.0
ISAB 3 B ...	8.0	M3/M3	10/ 13/ 15/ 18/ 20/ 25/ 30/ 35/ 40	6.0
ISAB 4 B ...	8.0	M4/M4	15/ 20/ 25/ 30/ 40	6.0
ISAB 5 B ...	9.5	M5/M5	20/ 30/ 40	10.0
ISAB 6 B ...	12.7	M6/M6	25/ 30/ 35/ 40/ 50	12.7

– dimensions = nominal size; deviation ± 0.5 mm; at **ISAB 3 C ...** L=10 => P/P'=3.5

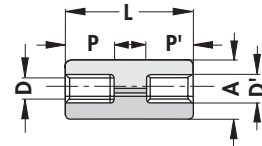

art. no.	dim. [mm]			
	A	D/D'	L	P/P'
ISAB 25 C ...	8.0	M2.5/M2.5	10/ 13/ 15/ 18/ 20/ 25/ 30	6.0
ISAB 3 C ...	8.0	M3/M3	10/ 13/ 15/ 18/ 20	6.0
ISAB 4 C ...	8.0	M4/M4	15/ 35	6.0
ISAB 5 C ...	9.5	M5/M5	20	10.0
ISAB 6 C ...	12.7	M6/M6	25	12.0
ISAB 6 C ...	12.7	M6/M6	30	12.7

dielectric strength:	27 kV/mm
creeping current resistance:	CTI 600
thread inserts:	brass
temperature range:	-30°C... +85°C (short term +200°C)
surface:	raw
plastic body:	polyamide 66
colour:	natural (opaque)

E 33

Spacers
Screw mounted guide rails
Ejectors
Vibration dampers

→ E 40
→ E 26 – 30
→ E 31
→ E 41

Mounting material for semiconduct. → E 44 – 48
Mounting parts for heatsinks → E 49 – 50
Thermal conductive material → E 2 – 24
Technical introduction → A 2 – 8

Miniature spacers with threads



- allows compact, insulated constructions
- reduced volume in case of stack assembly
- insulated mounting of heatsinks, PCB, housingparts etc.
- very good mechanical stability due to brass inserts
- dimensions = nominal size: deviation ± 0.5 mm
- ... please indicate length "L"

art. no.	S	type of thread	dim. [mm] L	max. diameter of the bushing
ISAM 2 A ...	6	M2.5	4/ 5/ 7/ 9/ 11/ 12	6
ISAM 3 A ...	7	M3	4/ 5/ 7/ 8/ 9/ 10	7
art. no.	S	type of thread	dim. [mm] L	max. diameter of the bushing
ISAM 2 B ...	6	M2.5	8/ 9/ 10/ 11	6
ISAM 3 B ...	7	M3	7/ 8/ 9/ 10/ 11/ 12	7
art. no.	S	type of thread	dim. [mm] L	max. diameter of the bushing
ISAM 2 C ...	6	M2.5	9	6
ISAM 3 C ...	7	M3	9/ 10/ 12	7
dielectric strength:	28 kV/mm			
creeping current resistance:	CTI 600			
thread inserts:	brass			
temperature range:	-30°C... +85°C (short term +200°C)			
surface:	raw			
plastic body:	polyamide 6			
colour:	natural (opaque)			

Spacers
Screw mounted guide rails
Ejectors
Vibration dampers

→ E 40
→ E 26 – 30
→ E 31
→ E 41

Mounting material for semiconduct. → E 44 – 48
Mounting parts for heatsinks → E 49 – 50
Thermal conductive material → E 2 – 24
Technical introduction → A 2 – 8

Distance hexagonal bolts insulating



field of applications:

- insulated assembly of stacked PCBs
- insulated assembly of stacked heatsinks with varying capacities
- insulated assembly of chassis plates in cases
- insulated supports in the wiring
- mechanically very stable, as threads are made of brass
- other lengths on request
- dimensions = nominal size: deviation ± 0.5 mm
- ... please indicate length "L"

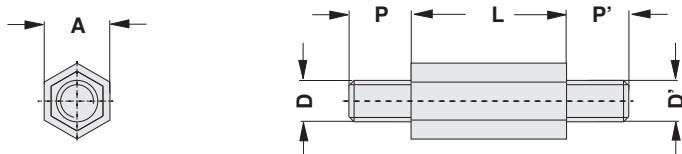

E 35

Spacers
Screw mounted guide rails
Ejectors
Vibration dampers

→ E 40
→ E 26 - 30
→ E 31
→ E 41

Mounting material for semiconduct. → E 44 - 48
Mounting parts for heatsinks → E 49 - 50
Thermal conductive material → E 2 - 24
Technical introduction → A 2 - 8

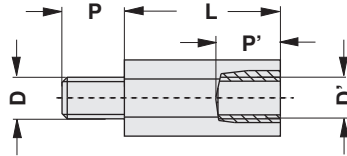
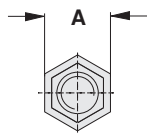
Distance hexagonal bolts insulating

art. no.	dim. [mm]			
	A	D/D'	L	P/P'
ISAS 25 B ...	6.35	M2.5/M2.5	15/ 20/ 25/ 30/ 35/ 40	6.0
ISAS 30 B ...	6.35	M3/M3	15/ 20/ 25/ 30/ 35/ 40/ 45/ 50	6.0
ISAS 40 B ...	8.00	M4/M4	15/ 20/ 25/ 30/ 35/ 40/ 45/ 50	6.0
ISAS 50 B ...	9.50	M5/M5	20/ 25/ 30/ 35/ 40/ 45/ 50	10.0
ISAS 60 B ...	12.70	M6/M6	25/ 30/ 35/ 40/ 45/ 50/ 60	12.7

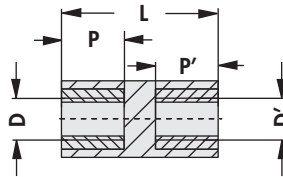
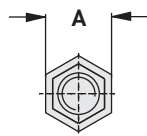

art. no.	dim. [mm]			
	A	D/D'	L	P/P'
ISAS 25 C ...	6.35	M2.5/M2.5	15/ 20/ 25/ 30/ 35/ 40	6.0
ISAS 30 C ...	6.35	M3/M3	15/ 20/ 25/ 30/ 35/ 40/ 45/ 50	6.0
ISAS 40 C ...	8.00	M4/M4	15/ 20/ 25/ 30/ 35/ 40/ 45/ 50	6.0
ISAS 50 C ...	9.50	M5/M5	20/ 25/ 30/ 35/ 40/ 45/ 50	10.0
ISAS 60 C ...	12.70	M6/M6	25/ 30/ 35/ 40/ 45/ 50/ 60	12.7

dielectric strength:	27 kV/mm
creeping current resistance:	CTI 600
thread inserts:	brass
temperature range:	-30°C... +85°C (short term +200°C)
surface:	raw
plastic body:	polyamide 66
colour:	natural (opaque)

Spacers
Screw mounted guide rails
Ejectors
Vibration dampers

→ E 40
 → E 26 – 30
 → E 31
 → E 41

Mounting material for semiconduct. → E 44 – 48
Mounting parts for heatsinks → E 49 – 50
Thermal conductive material → E 2 – 24
Technical introduction → A 2 – 8

Spacers with internal and external thread

- other lengths and threads on request
- ... please indicate length "L"

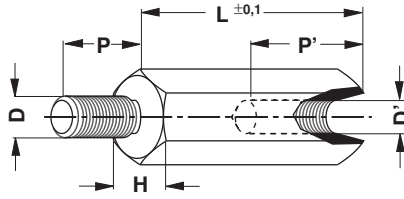

art. no.	dim. [mm]				
	H	D/D'	L	P	P'
GBM 2550 ...	5	M2.5	5	6	2.5
GBM 2550 ...	5	M2.5	10	6	5.0
GBM 2550 ...	5	M2.5	15/ 20	6	8.0
GBM 2550 ...	5	M2.5	25/ 30/ 35	8	10.0
GBM 3050 ...	5	M3	5	8	2.5
GBM 3050 ...	5	M3	10/ 12/ 14	8	5.0
GBM 3050 ...	5	M3	15/ 18/ 20	8	10.0
GBM 3050 ...	5	M3	25/ 30/ 35/ 40/ 45/ 50	10	10.0
GBM 4070 ...	7	M4	5	8	2.5
GBM 4070 ...	7	M4	10	8	5.0
GBM 4070 ...	7	M4	15	8	8.0
GBM 4070 ...	7	M4	20	8	10.0
GBM 4070 ...	7	M4	25/ 30/ 35/ 40/ 45/ 50	10	10.0
GBM 5080 ...	8	M5	10	8	5.0
GBM 5080 ...	8	M5	15/ 20	8	6.0
GBM 5080 ...	8	M5	25/ 30/ 35/ 40/ 45/ 50	10	10.0
material:	brass				
surface:	6 µm nickel-plated, solderable				

- other lengths and threads on request
- ... please indicate length "L"

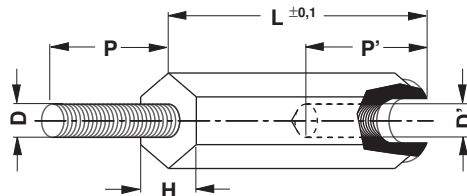

art. no.	dim. [mm]				
	H	D/D'	L	P	P'
GBP 3060 ...	6	M3	10	8	7
GBP 3060 ...	6	M3	12	8	8
GBP 3060 ...	6	M3	15/ 18/ 20/ 25/ 30	8	10
GBP 4080 ...	8	M4	10	8	7
GBP 4080 ...	8	M4	12	8	9
GBP 4080 ...	8	M4	15/ 18/ 20/ 25/ 30/ 35/ 40/ 45	8	10
material:	polyamide, GF reinforced				
temperature range:	-30°C... +110°C				
colour:	black				

E 37

Spacers
Screw mounted guide rails
Ejectors
Vibration dampers

→ E 40
→ E 26 – 30
→ E 31
→ E 41

Mounting material for semiconduct. → E 44 – 48
Mounting parts for heatsinks → E 49 – 50
Thermal conductive material → E 2 – 24
Technical introduction → A 2 – 8

Distance sleeves with internal thread

- other lengths and threads on request
- ... please indicate length "L"

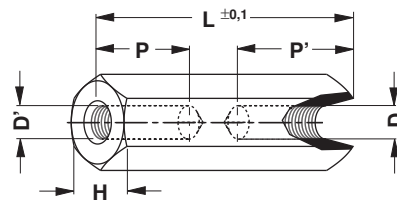

art. no.	dim. [mm]				
	H	D/D'	L	P	P'
ABM 2550 ...	5	M2.5	5/ 8/ 10/ 12/ 15	=L	—
ABM 2550 ...	5	M2.5	18	8	8
ABM 2550 ...	5	M2.5	20/ 25/ 30/ 35/ 40/ 45/ 50	10	10
ABM 3050 ...	5	M3	5/ 8/ 9/ 10/ 12/ 13/ 15	=L	—
ABM 3050 ...	5	M3	16/ 18/ 19	8	8
ABM 3050 ...	5	M3	20/ 25/ 29/ 30/ 35/ 40/ 45/ 50	10	10
ABM 4070 ...	7	M4	5/ 8/ 10/ 12/ 15	=L	—
ABM 4070 ...	7	M4	18	9	9
ABM 4070 ...	7	M4	20/ 25/ 30/ 35/ 40/ 45/ 50	10	10
ABM 5080 ...	8	M5	5/ 12/ 15	=L	—
ABM 5080 ...	8	M5	20/ 30/ 40/ 50	10	10
material:	brass				
surface:	6 µm nickel-plated, solderable				

- other lengths and threads on request
- ... please indicate length "L"

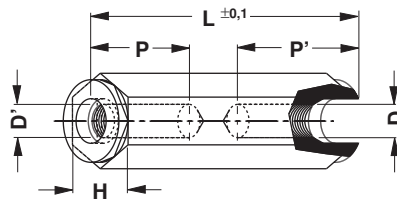

art. no.	dim. [mm]				
	H	D/D'	L	P	P'
ABP 2550 ...	5	M2.5	10	=L	—
ABP 2550 ...	5	M2.5	15/ 20/ 25/ 30	6	6
ABP 3060 ...	6	M3	10/ 12/ 15	=L	—
ABP 3060 ...	6	M3	20	8	8
ABP 3060 ...	6	M3	25/ 30	10	10
ABP 4080 ...	8	M4	10/ 15/ 20	=L	—
ABP 4080 ...	8	M4	30/ 40	10	10
material:	polyamide, GF reinforced				
temperature range:	-30°C... +110°C				
colour:	black				

Spacers

Screw mounted guide rails

Ejectors

Vibration dampers

→ E 40

→ E 26 - 30

→ E 31

→ E 41

Mounting material for semiconduct.

Mounting parts for heatsinks

Thermal conductive material

Technical introduction

→ E 44 - 48

→ E 49 - 50

→ E 2 - 24

→ A 2 - 8

Distance sleeves for PCB in HP grid



ABM TE

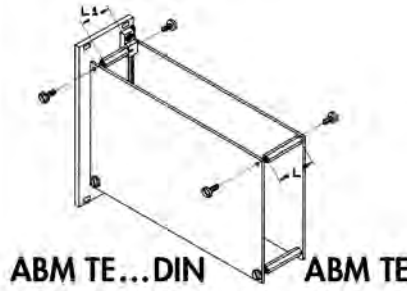

ABM TE...DIN ABM TE

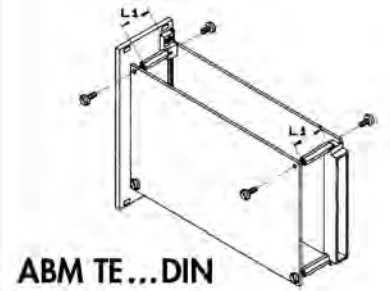

ABM TE...DIN

- these internally threaded distance sleeves mount PCBs to the correct pitch for insertion into subracks
- **ABM TE**: spacer between two PC boards
- **ABM TE ... DIN**: spacer between two PC boards, one of them equipped with DIN-connector resp. A front panel/PCB Interconnection device VS 1
- spacers with internal and external thread to HP grid on request

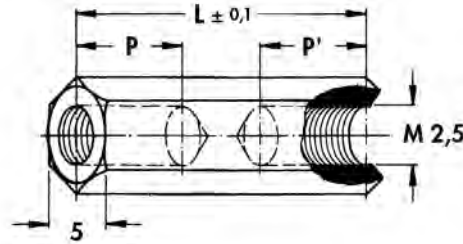

art. no.	suitable for TE	dim. [mm]	
		L	P/P'
ABM TE 04	4	18.72	8
ABM TE 06	6	28.88	8
ABM TE 08	8	39.04	8

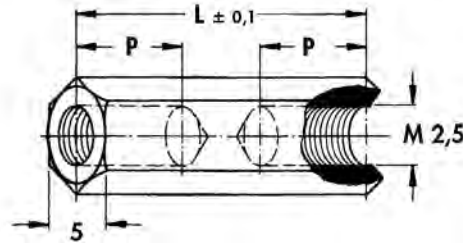

art. no.	suitable for TE	dim. [mm]	
		L	P
ABM TE 04 DIN	4	12.72	=L
ABM TE 06 DIN	6	22.88	8
ABM TE 08 DIN	8	33.04	8

material:	brass
surface:	8 μm nickel-plated, solderable

- ... please indicate length "L"

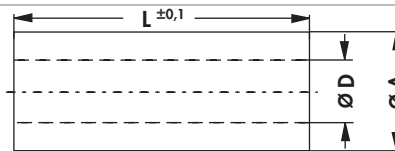

art. no.	dim. [mm]		
	A	D	L
AHM 3260...	6	3.2	1/ 2/ 3/ 4/ 5/ 6/ 7/ 8/ 9/ 10/ 12/ 15/ 18/ 25/ 30
AHM 4380...	8	4.3	2/ 3/ 4/ 5/ 6/ 7/ 8/ 9/ 10/ 12/ 15/ 18/ 20

material:	brass
surface:	8 μm nickel-plated, solderable

Distance spacers

– special lengths on request

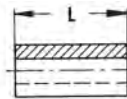
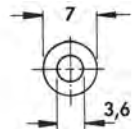

art. no.	C [mm]	art. no.	C [mm]	art. no.	C [mm]
DR 071 V0	1	DR 079 V0	9	DR 725 V0	25
DR 072 V0	2	DR 710 V0	10	DR 730 V0	30
DR 073 V0	3	DR 711 V0	11	DR 735 V0	35
DR 074 V0	4	DR 712 V0	12	DR 740 V0	40
DR 075 V0	5	DR 713 V0	13	DR 745 V0	45
DR 076 V0	6	DR 714 V0	14	DR 750 V0	50
DR 077 V0	7	DR 715 V0	15	DR 760 V0	60
DR 078 V0	8	DR 720 V0	20		

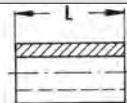
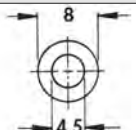

art. no.	C [mm]	art. no.	C [mm]	art. no.	C [mm]
DR 081 V0	1	DR 089 V0	9	DR 825 V0	25
DR 082 V0	2	DR 810 V0	10	DR 830 V0	30
DR 083 V0	3	DR 811 V0	11	DR 835 V0	35
DR 084 V0	4	DR 812 V0	12	DR 840 V0	40
DR 085 V0	5	DR 813 V0	13	DR 845 V0	45
DR 086 V0	6	DR 814 V0	14	DR 850 V0	50
DR 087 V0	7	DR 815 V0	15	DR 860 V0	60
DR 088 V0	8	DR 820 V0	20		

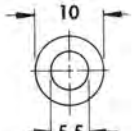

art. no.	C [mm]	art. no.	C [mm]	art. no.	C [mm]
DR 105 V0	5	DR 125 V0	25	DR 140 V0	40
DR 110 V0	10	DR 130 V0	30	DR 145 V0	45
DR 115 V0	15	DR 135 V0	35	DR 150 V0	50
DR 120 V0	20				





material:	polyamide
heat distortion:	180°C
temperature range:	+180°C
colour:	black
class of flammability:	UL 94 V-0

Construational elements to vibration damping and insulation



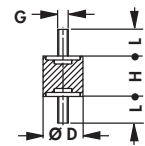

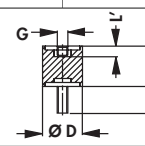

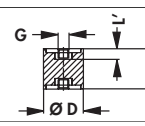

- universal applicable round metal, antivibration buffers for solving vibration problems
- other lengths and hardness range on request
- ... **please indicate height "H"**

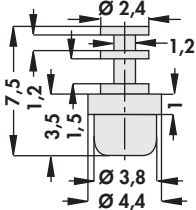
Field of applications:

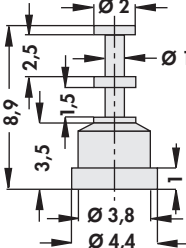
- reduction of dynamic component stress
- vibration insulation for disc drives and motors
- impact reducing on sensitive instruments
- reduction of the noise level
- prevention of vibration resonance phenomena (amplified effect)
- compensation of mechanical inbalances

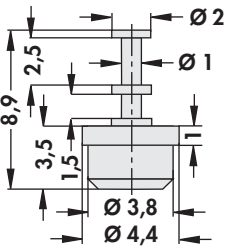
					
art. no.	dim. [mm]				
	H	type of thread	Ø D	L	
SMP 410 A ...	10	M4	10	10	
SMP 415 A ...	15	M4	15	10	
SMP 515 A ...	15	M5	15	12	
					
art. no.	dim. [mm]				
	H	type of thread	Ø D	L'	L
SMP 410 B ...	10	M4	10	4	10
SMP 415 B ...	15	M4	15	4	10
SMP 515 B ...	15	M5	15	5	12
					
art. no.	dim. [mm]				
	H	type of thread	Ø D	L'	
SMP 410 C ...	15/ 20	M4	10	4	
SMP 415 C ...	15/ 20	M4	15	4	
SMP 515 C ...	20	M5	15	5	
material:	rubber-metal connection				
rubber:	natural rubber (NR according to ISO)				
hardness range:	~ 50 Shore A				
extensibility and tebsile strength:	very good				
colour:	black				
metall parts:	steel tin-plated				
temperature range:	-40°C... +80°C (short term +90°C)				

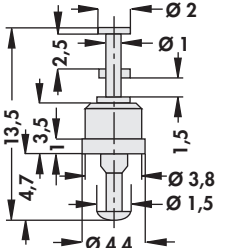
Solder terminals

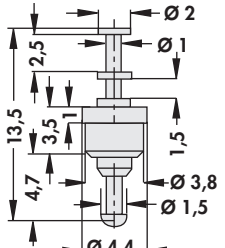
art. no. LSD 07520		
art. no. LSD 08910		
art. no. LSD 08920		
art. no. LSD 13510		
art. no. LSD 13520		
material:		insulating body: PTFE (teflon)
contact pin:		brass, 2 µm Ni, 4 µm Ag
temperature range:		-200°C ... +260°C

Screw mounted guide rails
 Ejectors
 Insulating distance sleeves
 Spacers

→ E 26 – 28
 → E 31
 → E 32 – 39
 → E 40

Insulating clamping parts
 Mounting parts for heatsinks
 Mounting material for semiconduct.
 Technical introduction

→ E 45
 → E 49 – 50
 → E 44
 → A 2 – 8

Solder pins

art. no. LS 101 ±0.6 mm	art. no. LS 102 ±0.6 mm	art. no. LS 103 ±0.6 mm	art. no. LS 104 ±0.6 mm	art. no. LS 105 ±0.5 mm
art. no. LS 106 ±0.8 mm	art. no. LS 107 ±0.5 mm			

$\frac{\downarrow}{\uparrow}$ = thickness

	LS
material	brass, 6 μm Sn

Mounting kits for insulation of power transistors

MST 3
MSTS 3

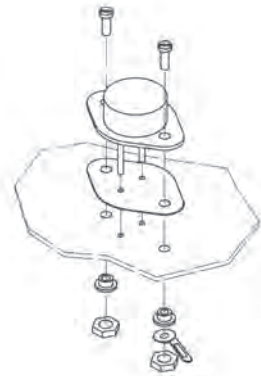

MST 220
MSTS 220

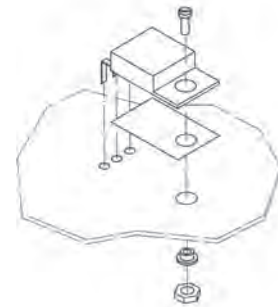

art. no.	for transistor	version	contents of delivery
MST 3	TO 3	with mica wafer GS 3	1 mica wafer, 2 insulator sleeves, 1 tin-plated solder lug, 2 cheese head screws, nickel-plated, 2 screw nuts M3 nickel-plated
MSTS 3	TO 3	with silicone wafer WS 3	1 silicone wafer, 2 insulator sleeves, 1 tin-plated solder lug, 2 cheese head screws, nickel-plated, 2 screw nuts M3 nickel-plated
MST 220	TO 220	with mica wafer GS 220	1 mica wafer, 1 tin-plated solder lug, 1 cheese head screw, nickel-plated, 1 screw nut M3 nickel-plated
MSTS 220	TO 220	with silicone wafer WS 220	1 silicone wafer, 1 insulator sleeve, 1 tin-plated solder lug, 1 cheese head screw, nickel-plated, 1 screw nut M3 nickel-plated

Snap rivet for quick fastening of TO 220

- detachable plastic snap rivet for quick fastening of transistors onto heatsinks and cooling plates (e.g. FK 212-CB, FK 216-CB, FK 222-220, FK 232, FK 233, FK 235-L 1)
- suitable for material thickness: 1 – 1.5 mm
- suitable for hole diameter: 3.5 – 4 mm
- * = bottom view, pin not inserted

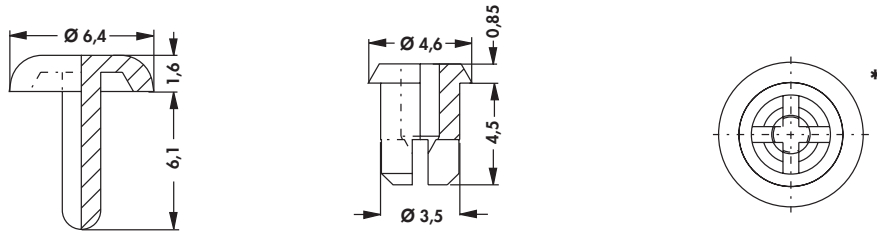
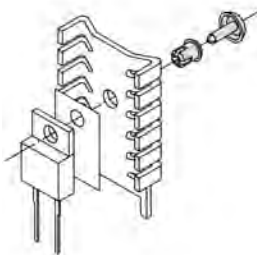

art. no.	for transistor
EPN 1	TO 220
material:	polysulphone, GF reinforced
temperature range:	-70°C... +180°C (5s+260°C)
class of flammability:	UL 94 V-0

Mounting parts for heatsinks
Spacers
Guide rails for PCBs
Finger-shaped heatsinks

→ E 49 – 50
→ E 40
→ E 26 – 30
→ C 2 – 3







Vibration dampers
Thermal conductive material
Retaining springs for transistors
Technical introduction

→ E 41
→ E 2 – 24
→ A 115 – 117
→ A 2 – 8

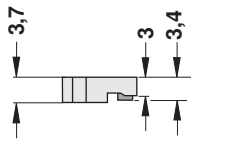
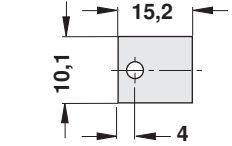
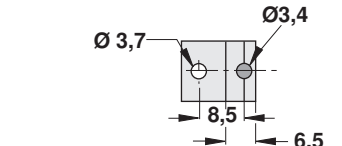
Insulating clamping parts for power transistors

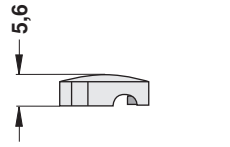
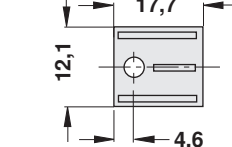
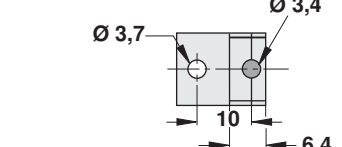
Plastic insulating clamping parts for mounting transistors in cases TO 220, TO 218 and TO 247 for enhanced dielectric strengths

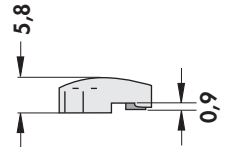
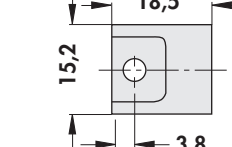
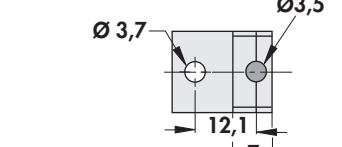
- electrically insulating assembly of the transistor by means of a plastic clamping part
- pin reaching into the hole of the transistor plate
- fastening of clamping part onto the mounting plate by screws, no electroinsulating connection to the transistor
- dielectric strength only determined by the insulating washer between transistor and mounting surface
- no insulating bush necessary, thus no dielectric breakdown

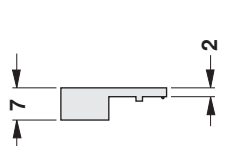
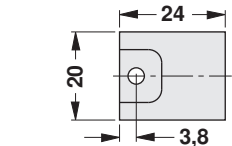
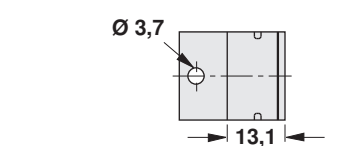
<p>art. no.</p>  <p>ISP 220</p>	 <p>3,7 3 3,4</p>	 <p>15,2 10,1 4</p>	 <p>Ø 3,7 Ø 3,4 8,5 6,5</p>
<p>art. no.</p>  <p>ISP 220 V</p>	 <p>5,6</p>	 <p>17,7 12,1 4,6</p>	 <p>Ø 3,7 Ø 3,4 10 6,4</p>
<p>art. no.</p>  <p>ISP 218</p>	 <p>5,8 0,9</p>	 <p>18,5 15,2 3,8</p>	 <p>Ø 3,7 Ø 3,5 12,1 7</p>
<p>art. no.</p>  <p>ISP 247</p>	 <p>7 2</p>	 <p>24 20 3,8</p>	 <p>Ø 3,7 13,1</p>
<p>material:</p> <p>dielectric strength:</p> <p>heat distortion:</p> <p>dielectric constant:</p> <p>dielectric loss factor:</p> <p>specific volume resistance:</p> <p>colour:</p> <p>class of flammability:</p>	<p>polyamide 6, GF reinforced</p> <p><27 kV/mm</p> <p>205°C (1.8 MPa); 135°C (8 MPa)</p> <p>8 [100 Hz]/4.5 [1 MHz]</p> <p>1300 [100 Hz] 450 [1 MHz]</p> <p>> 10¹³ Ω·cm</p> <p>black</p> <p>UL 94 V-0</p>		

Mounts

art. no. MS 53 3 TO 5	art. no. MS 53 7 TO 5	art. no. MS 53 25 TO 5	art. no. MS 54 25 TO 5	art. no. MS 58 5 TO 5-8 p.
art. no. MS 58 7 TO 5-8 p.	art. no. MS 56 15 TO 5-6 p.	art. no. MS 58 15 TO 5-8 p.	art. no. MS 510 15 TO 5-10 p.	art. no. MS 3518 25 TO 5/ TO 18
art. no. MS 3518 35 TO 5/ TO 18	art. no. MS 34 518 TO 5/ TO 18	art. no. MS 183 25 TO 18	art. no. MS 184 25 TO 18	art. no. MS 183 35 TO 18
art. no. MS 184 35 TO 18	art. no. MS 183 7 TO 18	art. no. MS 184 7 TO 18	art. no. MS 84 4 TO 8	art. no. MS 923 25 TO 92
art. no. MS 4016 max. 16 contacts	art. no. US 58 4 TO 5	art. no. US 512 4 TO 5		

* = **transfer washer**: the US-pads convert the TO 5 pin circle to a pitch of 2.54 mm

material:	polyamide 6, GF reinforced
temperature range:	-40°C... +205°C
class of flammability:	UL 94 V-0 (at thickness ≥3mm), UL 94 V-1

Mounting parts for heatsinks
Heatsinks for PCB
Profiles for PCB mounting
Thermal conductive material

→ E 49 – 50
→ A 89 – 93
→ A 89 – 112
→ E 2 – 24

Insulating distance sleeves
Finger-shaped heatsinks
Retaining springs for transistors
Technical introduction

→ E 32 – 34
→ C 2 – 3
→ A 115 – 117
→ A 2 – 8

E 46

Mounts

Mounts for power transistors

- for TO 220, TO 219, TO 202 and similar
- for vertical and horizontal mounting
- also suitable as mounting bracket for angled connections

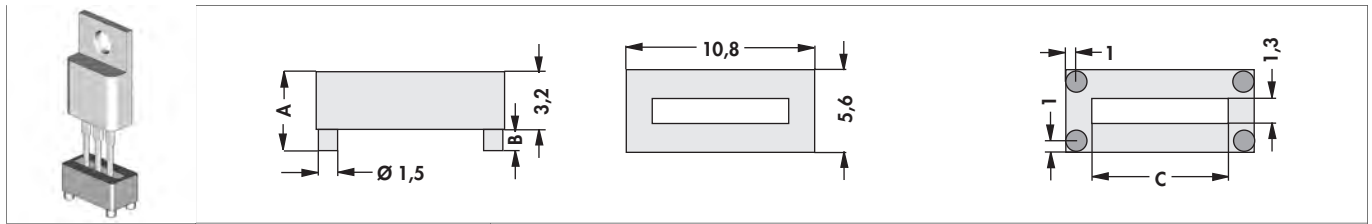

art. no.	colour	dim. [mm]		
		A	B	C
MLW 32	white	3.2	—	7.1
MLW 44	white	4.4	1.3	7.1
MLW 51	white	5.1	1.9	7.1

material:	polyamide 6 (nylon)
temperature range:	-40°C... +120°C
class of flammibility:	UL 94 V-2

Mounts for rectangular LEDs

- for LED 2x4 mm oder 2x5 mm
- symmetric version for easy assembly
- self-adhesive

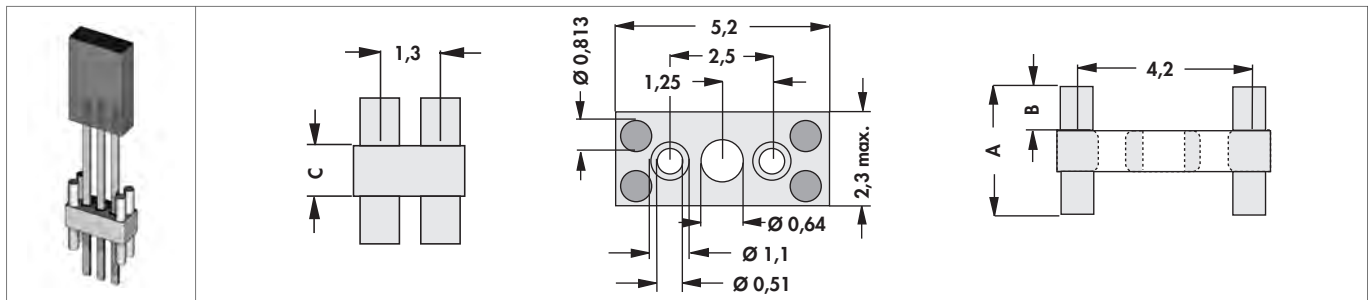





art. no.	colour	dim. [mm]		
		A	B	C
MRL 20	white	2	0.5	1



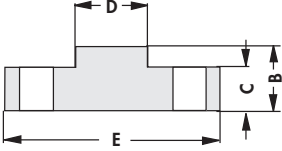
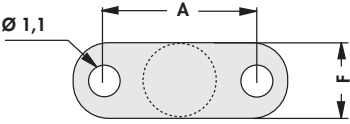

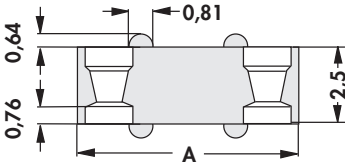
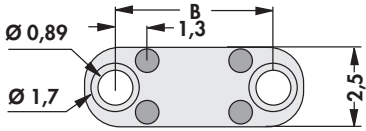

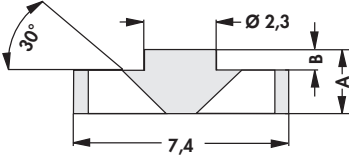
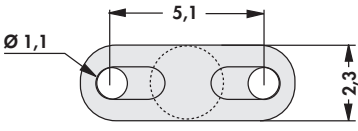

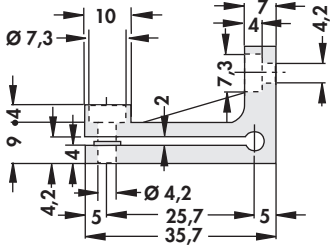
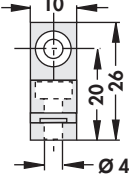

material:	polyamide 6 (nylon)
temperature range:	-40°C... +120°C
class of flammibility:	UL 94 V-2

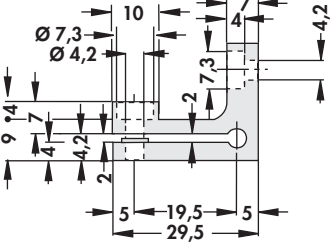
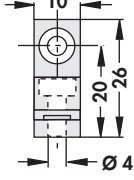
Mounts for discrete components

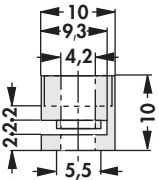
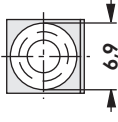

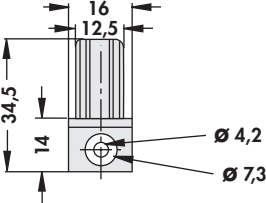
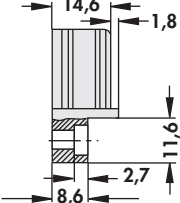
– suitable for various components e.g. resistors, capacitors etc.

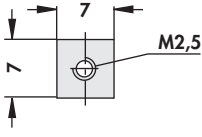
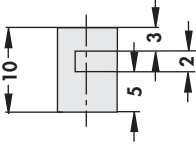
			
art. no.	dim. [mm]	art. no.	dim. [mm]
	A B C D E F		A B C D E F
MD A 04	2.5 1.1 0.55 1.3 4.6 2.3	MD A 09	7.6 1.1 0.66 3.6 9.9 2.3
MD A 06	3.8 1.1 0.55 2.3 6.9 3.2	MD A 12	10.2 1.1 0.76 4.8 12.4 2.3
MD A 07	5.1 1.1 0.55 2.3 7.4 2.3		
			
art. no.	dim. [mm]	art. no.	dim. [mm]
	A B		A B
MD B 07	7.6 5.1	MD B 12	12.7 10.2
MD B 10	10.2 7.6	MD B 15	15.2 12.7
MD B 11	11.4 8.9		
			
art. no.	dim. [mm]	art. no.	dim. [mm]
	A		A B
MD C 13	1.3	MD C 22	2.2 0.89
material:	polyamide 6 (nylon)		
temperature range:	-30°C... +110°C		
class of flammability:	UL 94 V-2		

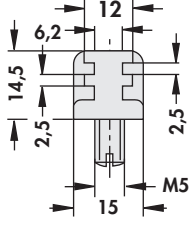
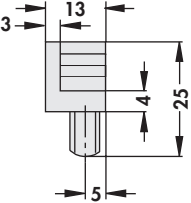
Mounting parts for heatsinks

<p>art. no.</p> <p>IS 1</p>			
<p>for SK 01, 02, 03, 11, 14, 21, 30, 34, 36, 39, 46, 69; heatsink length: 50 mm</p>			
<p>art. no.</p> <p>IS 2</p>			
<p>for SK 01, 02, 03, 11, 14, 21, 30, 34, 36, 39, 46, 69; heatsink length: 37.5 75 100 mm</p>			
<p>art. no.</p> <p>IS 3</p>			
<p>for SK 01, 02, 03, 11, 14, 21, 30, 34, 36, 39, 46, 69</p>			
<p>art. no.</p> <p>IS 4</p>			
<p>for SK 06</p>			
<p>art. no.</p> <p>IS 5</p>			
<p>for SK 20</p>			
<p>art. no.</p> <p>IS 6</p>			
<p>for SK 67</p>			
<p>material:</p>		<p>polyamide 6, GF reinforced</p>	
<p>class of flammability:</p>		<p>UL 94 V-0</p>	

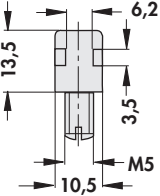
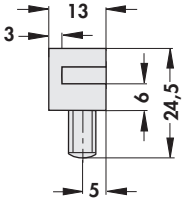
Mounting parts for heatsinks

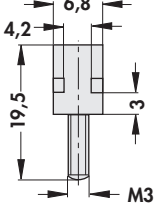
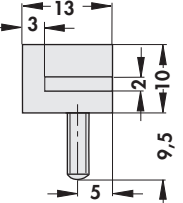

art. no.			
IS 7			
art. no.			
IS 8	for SK 20		
material:	polyamide 6, GF reinforced		
class of flammability:	UL 94 V-0		

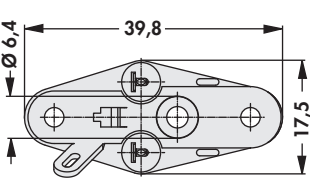
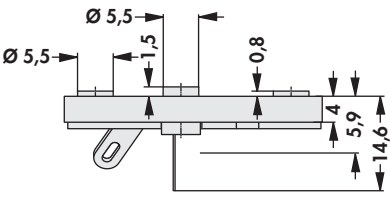
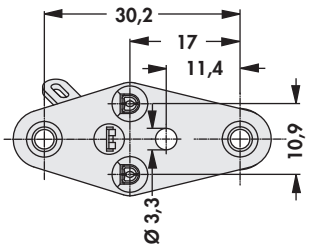
Sockets for power transistors TO 3

			
art. no.	no. of contacts		
TF 3 2	3		
insulating body material:	stanyl PA 4.6		
contact:	CuSn-alloy, CuSn 6; Ni 1-2µm, Au 0.2µm		
current rating:	15 A max.		
contact resistance:	<10 mΩ		
temperature range:	-65°C ... +290°C		
capacity:	1 pF		
test voltage:	1650 V		
class of flammability:	UL 94 V-0		

Insulating caps

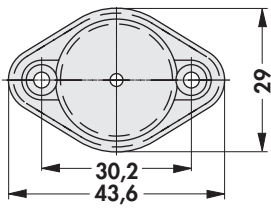
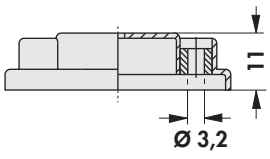
– different transistor flange levels will be by the sleeves

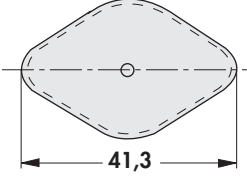
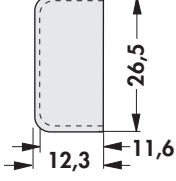
<p>art. no.</p> <p>IK 341 3</p>			
<p>art. no.</p> <p>IK 3</p>			
<p>material:</p>		<p>polyamide, GF reinforced</p>	
<p>pressed-in sleeves:</p>		<p>brass, nickel-plated</p>	
<p>class of flammability:</p>		<p>UL 94 V-0</p>	

Insulating bush

art. no. IB 1 / IBT 1	art. no. IB 2 / IBT 2	art. no. IB 3 / IBT 3	art. no. IB 4 / IBT 4	art. no. IB 5
art. no. IB 6 / IBT 6	art. no. IB 7 / IBT 7	art. no. IB 8 / IBT 8	art. no. IB 9 / IBT 9	art. no. IB 10 / IBT 10
art. no. IB 11 / IBT 11	art. no. IB 12 / IBT 12	art. no. IB 13	art. no. IB 14 / IBT 14	art. no. IB 15 / IBT 15
art. no. IB 16	art. no. IB 17	art. no. IB 18 / IBT 18		

	IB 1 - IB 7 / 18	IBT 1 - IBT 15 / 18	IB 8 - IB 17
material	polyamide 4.6, GF reinforced	PTFE (teflon)	thermoplastic resin
form stability	-40°C ... +250°C (1.8 MPa)	-260°C ... +250°C	-40°C ... +200°C
dielectric strength	30 kV/mm	40 kV/mm	38 kV/mm
class of flammability		UL 94 V-0	

Mica wafers
Thermal conductive material
Mounting for TO 3 angle
Insulating distance sleeves

→ E 19
→ E 2 - 5
→ A 125
→ E 32 - 128

Aluminium oxide wafers
Thermal conductive paste
Thermal conductive glue
Technical introduction

→ E 17 - 18
→ E 21 - 22
→ E 23 - 24
→ A 2 - 8

High quality surface treatment for electronic components



Gold-plating

properties: high resistance to wear, good corrosion resistance, temperature stability and solderability

process: drum technology

materials: non-ferrous metals

coating system: copper/nickel/gold



Tin-plating

properties: solderable layers with improved tarnishing and corrosion resistance

process: drum technology

materials: non-ferrous metals

coating system: copper/nickel/tin

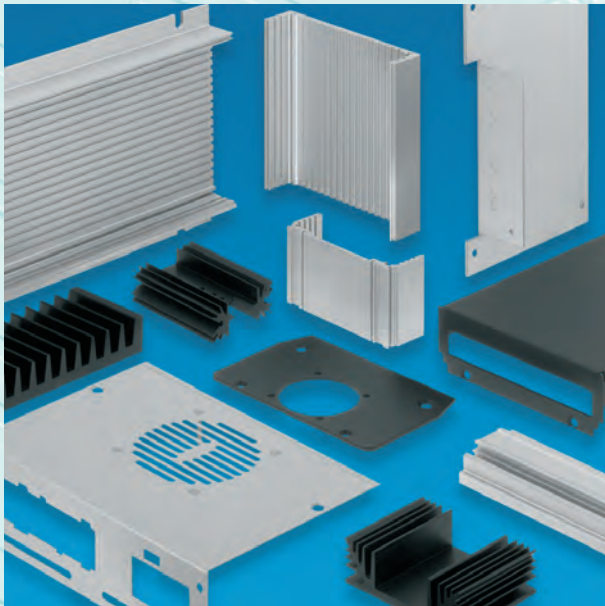

Anodising

performance: fabrication of corrosion resistant, decorative oxide films

process: anodic oxidation in fully automated equipment

materials: aluminium and aluminium alloys

max. component size: 1500 x 2000 x 450 mm

colour: natural aluminium or black

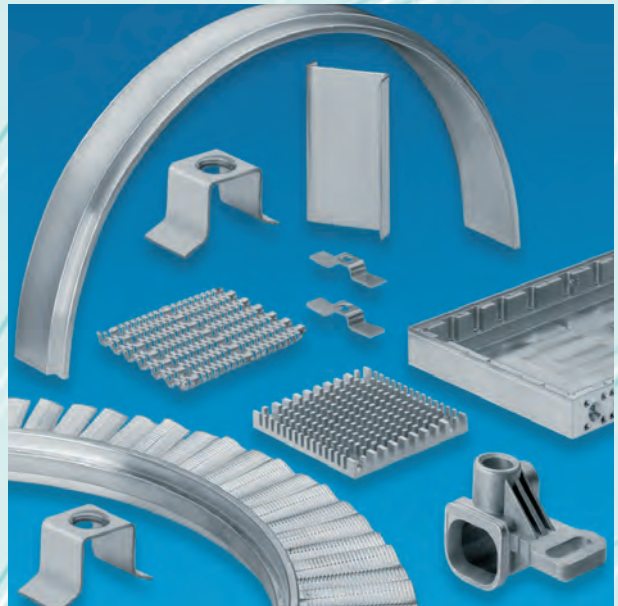

Degreasing

performance: degreasing of oily or greasy metallic surfaces

process: steam degreasing using chlorinated hydro-carbons in hermetically sealed equipment

material: aluminium and aluminium alloys

min. component size: 30 x 30 x 30 mm

max. component size: 600 x 400 x 380 mm

max. component weight: 80 kg

High quality surface treatment for electronic components

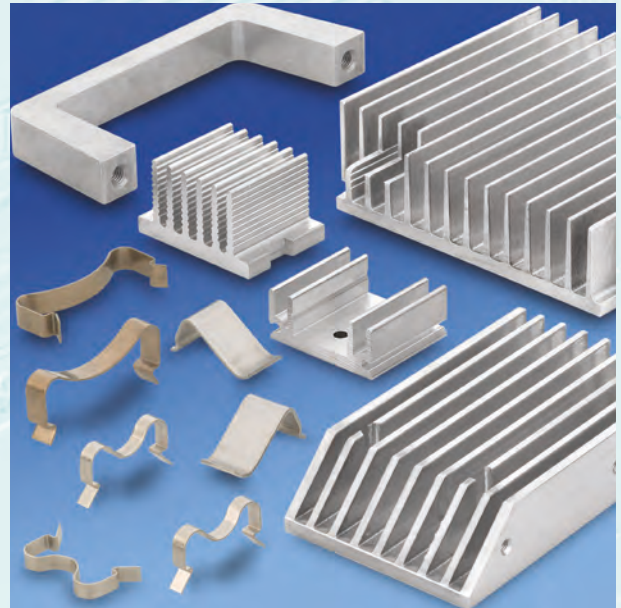

Transparent passivating (surface free from chromium VI)

characteristics: environmental compatibility due to chrome free passivation of the aluminium surfaces
process: fabrication of conversion coatings by immersion process
materials: aluminium und aluminium alloys
max. component size: 1500 x 2000 x 450 mm
colour: natural aluminium or black

Vibratory grinding

characteristics: deburring, removing of sharp edges, rough and fine grinding
process: treatment using vibration technique and grinding tools (trowalization)
materials: metallic, aluminium favoured
max. component size: 230 x 200 mm



Anodisation facility

- economization of water by using spray-rinsing, automatized ion exchange installation, cascade water guided system and recirculation of splash water
- reduction of electrical energy by means of current density regulation
- reduction of chemicals by recirculation of the dragged-off chemicals using a compensation of the evaporation losses
- recycling of the sulphuric acid out of the anodizing baths

Certificate

Standard **ISO 9001:2008**

Certificate Registr. No. 01 100 052055

TÜV Rheinland Cert GmbH certifies:

Certificate Holder:



Fischer Oberflächenveredelung GmbH
Nottebohmstraße 28
D - 58511 Lüdenscheid

Scope: surfaces for electronics: goldplating, tinplating, nickelplating, anodizing, passivating, deburring.

An audit was performed, Report No. 052055. Proof has been furnished that the requirements according to ISO 9001:2008 are fulfilled.
The due date for all future audits is 06-12 (dd.mm).

Validity: The certificate is valid from 2014-12-15 until 2017-12-14.
First certification 2005

2014-11-11

TÜV Rheinland Cert GmbH
Am Grauen Stein 51105 Köln



DGA-ZM-58-95-00

www.tuv.com

 **TÜVRheinland®**
Precisely Right.

General Business conditions**1. General provisions**

Our deliveries are exclusively subject to the conditions set forth herein which shall be deemed to be explicitly accepted by the purchaser. No conditions which may appear on the purchaser's order shall be binding on us, even without our express contradiction.

2. Quotations and orders

Our quotations are not binding on us. This applies also to information contained in price lists, leaflets etc.. Delivery dates stated in our quotations or given to the purchaser by any other means are approximate, and we endeavour to keep to them. Delays in delivery shall give no right to claims, unless we have explicitly confirmed such delivery dates and an adequate period of grace granted to us has expired. Orders shall only be binding on us when they are explicitly confirmed in writing, regardless of the form in which they have been placed with us. Furthermore the characteristics of our samples cannot be regarded as guaranteed characteristics.

3. Prices

Prices shall be valid only when confirmed by us in writing. They are exclusive of VAT at the current rate and incidentals such as postage and packing, freight, insurance etc.. If delivery is made more than 4 months after the date of order, we shall be entitled to invoice the price valid at the date of despatch, even though different prices were initially confirmed. The price valid at the date of despatch shall also apply if the order was confirmed without prices. When an order on call is placed, partial deliveries shall be invoiced at the price valid at the date of despatch. Any request by the purchaser for subsequent modifications shall give us the right to amend prices.

4. Conditions of payment

Payment of the invoice amount shall become due following receipt of the invoice. Payments made within 14 days of the date of invoice give the right to a 2% cash discount. Payments 30 days after the date of invoice shall be made without any deduction. If the purchaser is in default with any payment, we are entitled to claim interest for such default at the normal rate for current accounts. If greater damage can be demonstrated to have been caused by the delay, we are entitled to request compensation for such damage.

5. Set-off, right to retention

Only uncontested or legally binding counter-claims may be offset against our invoices. Any right to a retention to be exercised by the purchaser in connection with our claims is explicitly excluded.

6. Delivery

Delivery of our goods is explicitly made on behalf of and at the risk of the purchaser. The risk shall pass on to the purchaser when the ordered goods leave our premises. The same applies if goods are collected in our premises after notification of their readiness. We decide at our discretion on the most economical delivery method without assuming any liability for the chosen means of delivery.

7. Specially manufactured goods

Components made according to a sample or a drawing or by special request must be taken over and paid for, unless they have a defect we are answerable for and which

makes the components completely unfit for the purchaser's purposes. If their fitness for the purchaser's purposes is only reduced, the purchaser may request a reduction of payment but the contract shall not be cancelled.

8. Quantities

We are entitled to supply quantities which are above or below the ordered quantities by up to 10%. Such deviations are usual in this trade and the deliveries are deemed as being in compliance with the contract. If delivery quantities fall below the ordered quantities there shall be no right to subsequent delivery of the missing quantity.

9. Reservation of proprietary rights

9.1. All goods supplied shall remain our property until all of our claims resulting from the contract have been paid in full. The purchaser is entitled to dispose of the purchased goods in the ordinary course of business transactions. Reservation of proprietary rights also applies to products resulting from processing, mixing up or combining our goods with goods of third parties, in which case we are considered as manufacturers. In the case where our goods are processed, mixed up or combined with goods of third parties, and the proprietary rights of such third parties remain in force, we are entitled to co-ownership according to the proportion of the amount invoiced for such processed goods. Such right to coownership shall be safeguarded by the purchaser.

9.2. The purchaser shall transfer to us, as a security, his claims against third parties resulting from the re-sale of our goods in full or in the proportion of our co-ownership (see subparagraph 9.1). He is entitled to collect the amount of such claims on our behalf until revoked or until cessation of his payments made to us. The purchaser is not entitled to assign these claims to third parties.

9.3. The purchaser is not entitled to mortgage or transfer the goods which are subject to reservation by way of security.

9.4. The purchaser shall advise us immediately at any seizure of our goods or of any infringement of our rights by third parties.

9.5. In case of a default in payment or a deterioration in the financial situation, we are entitled to request immediate handing over of the goods which are subject to reservation. Any time limited claims shall immediately become due.

9.6. If the value of the securities exceeds our claims by more than 20%, securities to a corresponding amount will be released by us on request at our discretion.

10. Warranty

10.1. We expressly point out that all information and data is given to the best of our knowledge and belief. The user is solely responsible for the proper use of our products and he should check their suitability for the intended application.

Fischer Elektronik do not assume any warranty, whether expressed or implied, for the suitability, function or merchantability of their products in specific or general applications, and they cannot be held liable for accidental or consequential damage due to non-observance of the above.

10.2. Claims for defects can only be considered if the purchaser has complied with his obligation to check and put forward a complaint as per § 377 HGB.

10.3. If goods have a defect attributable to us, we are obliged to provide subsequent fulfilment, excluding the purchaser's right to withdraw from the contract or to reduce the purchase price (abatement), unless we are entitled to refuse subsequent fulfilment by virtue of legal provisions. The purchaser shall grant us an adequate period of grace for subsequent fulfilment. Subsequent fulfilment may at our discretion be an elimination of the defect (rectification) or the supply of new products.

10.4. If rectification of the defect has failed, the purchaser shall be entitled to request a reduction in the purchase price (abatement) or to withdraw from the contract. Rectification shall be deemed to have failed after the second vain attempt, unless further attempts are reasonable in view of the object of the contract and can be reasonably imposed on the purchaser.

10.5. The purchaser's right to put forward further claims for damages shall remain unaffected by this.

10.6. The purchaser's warranty claims shall come under the limitation of time which is 12 months from the delivery of the goods to the purchaser, unless we have fraudulently concealed the defect. In this case, the legal provisions shall apply.

10.7 The purchaser's claims for damages shall come under the limitation of time which is 12 months from the delivery of the goods. This does not apply if the threat to life, bodily injury or injury to health is imputable to us, our legal representatives or other vicarious agents, or if we or our legal representatives have been grossly negligent, or if our vicarious agents have acted deliberately.

11. Withdrawal

When delivery in accordance with the contract is not possible for reasons beyond our control, we are entitled to withdraw from the contract. Such withdrawal shall not entitle the purchaser to assert any right against us.

12. Place of performance, place of venue, applicable law

12.1. The place of performance and the place of venue for deliveries and payments and for any litigation arising between us and the purchaser shall be the headquarters of our company.

12.2. The relations between the parties to the contract shall be exclusively governed by the law of the Federal Republic of Germany. The application of the UN Conventions on contracts for the international sale of goods is excluded.

If any provision herein is or will become invalid, such provision shall not affect the validity of the remaining provisions. The invalid provision shall be replaced by a valid provision which shall meet as closely as possible the legal and commercial purpose of the original one.

How to find us

Fischer Elektronik GmbH und Co. KG

Nottebohmstraße 28

D – 58511 Lüdenscheid

Telefon: +49 (0) 23 51 / 4 35 - 0

Telefax: +49 (0) 23 51 / 4 57 54

info@fischerelektronik.de

www.fischerelektronik.de

www.facebook.de/fischerelektronik

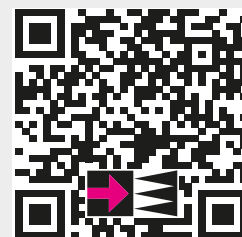
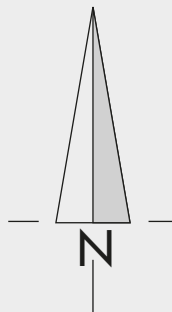

town centre

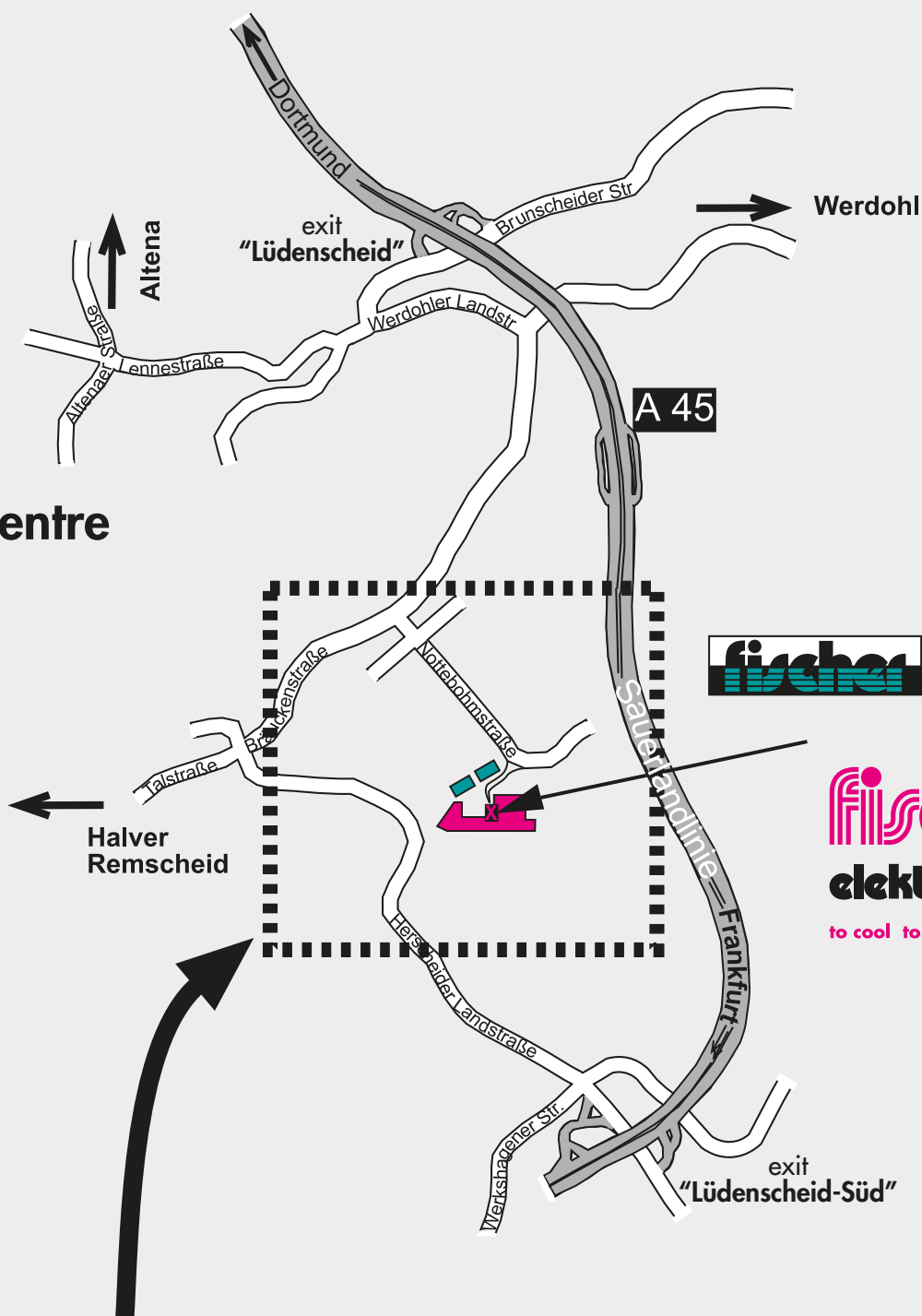

to cool to protect to connect

The information given in this catalogue were established and examined carefully. Nevertheless, mistakes or printing errors, and especially technical modifications and updating and improvement of our products, cannot be excluded. All trade marks are recognised even if they are not specifically identified or mentioned. No identification does not imply that a product or trademark is not registered. No part of this catalogue may be reproduced or distributed without prior written consent of Fischer Elektronik. All data contained in this catalogue, in texts, illustrations, documents and descriptions are subject to copyright and the provisions of DIN ISO 16016. All rights reserved.

© Copyright Fischer Elektronik 1969 ... 2014

Fischer Elektronik GmbH & Co. KG

P.O. Box 1590
D-58465 Lüdenscheid

House Address

Nottebohmstr. 28
D-58511 Lüdenscheid
Fon: +49 (0) 23 51 4 35-0
Fax: sales +49 (0) 23 51 4 57 54
purchasing +49 (0) 23 51 45 94 33
exports +49 (0) 23 51 43 51 85
info@fischerelektronik.de
www.fischerelektronik.de



Cases
19" technology
Test equipment



Sockets
Connectors
Brackets



Slip-Case
for collecting
the catalogues

Fischer Elektronik GmbH & Co. KG

Nottebohmstraße 28

D - 58511 Lüdenscheid

Fon +49 (0) 23 51 4 35 - 0

Fax +49 (0) 23 51 4 57 54

E-mail info@fischerelektronik.de

Website www.fischerelektronik.de

Find us on
Facebook



X-ON Electronics

Largest Supplier of Electrical and Electronic Components

Click to view similar products for [fisher manufacturer](#):

Other Similar products are found below :

[FR 105 52 220 ME](#) [FR 120 42 200 ME](#) [GEL 28 30](#) [GEL 45 10](#) [GEL 45 50](#) [GEL 60 10](#) [AKG 33 20 80 ME](#) [AKG 69 24 100 ME](#) [BL 16 SMD](#)
[067 12](#) [ICKSR40X30](#) [LA 17 150 230](#) [LA 21 150 230](#) [LA 21 150 24](#) [LA 27 K 100 12](#) [LA 27 K 100 24](#) [LA 27 K 150 12](#) [LA 27 K 50 24](#)
[SK4615AL](#) [SK 47 250 SA](#) [SK56920AL](#) [SK57225SA](#) [SK57720AL](#) [SK58420AL](#) [SK58437.5SA](#) [SK 622 1000 AL](#) [SK 622 1000 SA](#) [SK 622](#)
[100 AL](#) [SK 623 100 SA](#) [SK 626 1000 SA](#) [SK 627 1000 AL](#) [SK 627 200 AL](#) [SK 627 200 SA](#) [SK 627 50 SA](#) [SK 632 100 AL](#) [SK 633 25 AL](#)
[SK 636 100 AL](#) [SK LED R 65 SA](#) [SK LED R 80 SA](#) [AKG 69 24 100 SA](#) [AKG 69 24 50 SA](#) [FR 80 42 160 ME](#) [GE K 80 42 100 SA](#) [GEL 10](#)
[GEL 45 30](#) [GEL 60 25](#) [GEL F 15 10](#) [TUF 120 42 220 ME](#) [TUF 55 16 200 SA](#) [LA 27 K 50 12](#) [LA 27 K 75 12](#)