

## 300mA, Low Noise High PSRR LDO Regulator

### Description

The FP6185 is a low dropout, low noise, high PSRR, very low quiescent current positive linear regulator. The FP6185 can supply 300mA output current with low dropout voltage at about 400mV that optimized for battery-powered systems or portable wireless devices such as mobile phones. The shutdown function can provide remote control for the external signal to decide the on/off state of FP6185 that consumes less than 0.1µA during shutdown mode.

The FP6185 regulator is able to operate with output capacitors as small as 1µF for stability. Other than the current limit protection, FP6185 also offers the on chip thermal shutdown feature providing protection against overload or any condition when the ambient temperature exceeds the maximum junction temperature.

The FP6185 offers high precision output voltage of ±2%. The FP6185 is available in SOT-23-5 and UTDFN – 4L (1mmx1mm) packages which features small size.

### Pin Assignment

#### S5 Package (SOT-23-5)

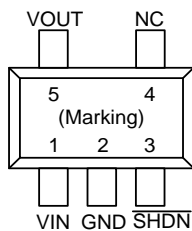

#### X6 Package (UTDFN-4L)(1mmx1mm) (Top view)

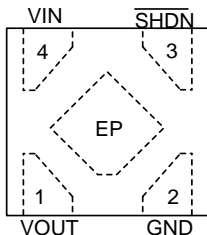

Figure 1. Pin Assignment of FP6185

### Features

- Low VIN and Wide VIN Range: 2V to 5.5V
- Guarantee Output Current 300mA
- ±2% Output Voltage Accuracy
- Output Noise 65µVrms from 10Hz to 100kHz
- V<sub>OUT</sub> Fixed 1.1V to 3.3V
- Low Dropout Voltage of 400mV at 300mA
- Ripple Rejection 70dB at 10kHz
- Very Low Quiescent Current at 35µA
- Needs Only 1µF Capacitor for Stability
- Thermal Shutdown Protection
- Current Limit Protection
- Miniature Packages:  
SOT-23-5, UTDFN-4L (1mmx1mm)
- RoHS Compliant

### Applications

- PDAs, Mobile phones, GPS, Smartphones
- Wireless Handsets, Wireless LAN, Bluetooth®, Zigbee®
- Portable Medical Equipment
- Other Battery Powered Applications

### Ordering Information

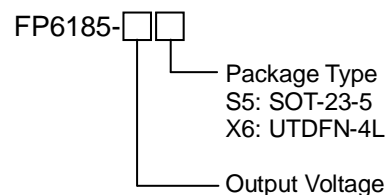

#### UTDFN-4L Marking

Part Number	Product Code
FP6185-	

## Typical Application Circuit

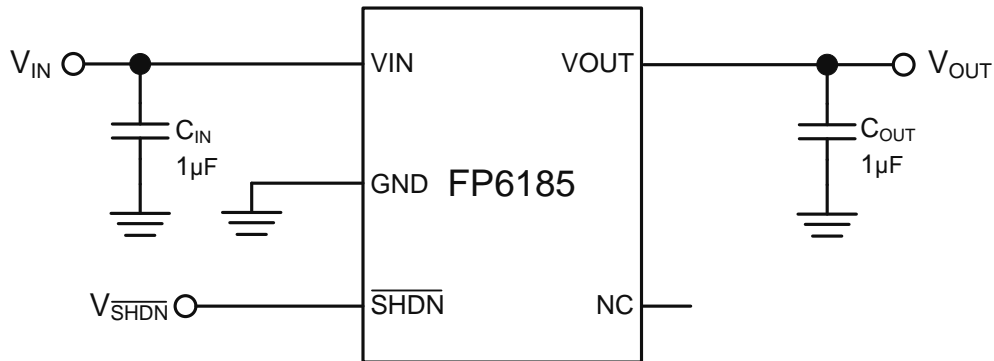

Figure 2. Typical Application Circuit of FP6185

Note 2: To prevent oscillation, it is recommended to use minimum 1µF X7R or X5R dielectric capacitors if ceramics are used as input/output capacitors.

## Functional Pin Description

PIN NUMBER		PIN NAME	FUNCTIONS
SOT-23-5	UTDFN-4L		
1	4	VIN	Power is supplied to this device from this pin which is required an input filter capacitor. In general, the input capacitor in the range of 1µF to 10µF is sufficient.
5	1	VOUT	The FP6185 is stable with an output capacitor 1µF or greater. The larger output capacitor will be required for application with larger load transients. The large output capacitor could reduce output noise, improve stability and PSRR.
4	-	NC	No connection
2	2	GND	Common ground pin
3	3	SHDN	Pull this pin high to enable IC, pull this pin low to shutdown IC. Floating this pin will be shutdown due to the built-in pull-low resistor.

## Block Diagram

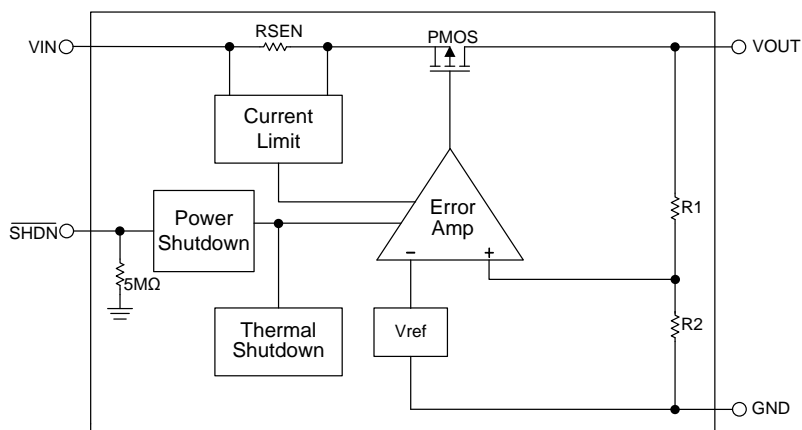

Figure 3. Block Diagram of FP6185

## Absolute Maximum Ratings <sup>(Note 1)</sup>

- Supply Voltage  $V_{IN}$  ----- -0.3V to +6.5V
- EN Voltage  $V_{EN}$  ----- -0.3V to  $V_{IN}+0.3V$
- Power Dissipation @  $T_A=25^{\circ}C$  &  $T_J=125^{\circ}C$  ( $P_D$ )
  - SOT23-5 ----- 0.4W
  - UTDFN-4L(1mmx1mm)----- TBD
- Package Thermal Resistance ( $\theta_{JA}$ ) <sup>(Note 2)</sup>
  - SOT23-5 ----- +250°C/W
  - UTDFN-4L(1mmx1mm)----- TBD
- Package Thermal Resistance ( $\theta_{JC}$ )
  - SOT23-5 ----- +130°C/W
  - UTDFN-4L(1mmx1mm)----- TBD
- Lead Temperature (Soldering, 10sec.) ----- 260°C
- Junction Temperature ( $T_J$ ) ----- -40°C to +150°C
- Storage Temperature ( $T_{STG}$ ) ----- -65°C to +150°C

Note 1 : Stresses beyond this listed under "Absolute Maximum Ratings" may cause permanent damage to the device.

Note 2 :  $\theta_{JA}$  is measured at 25°C ambient with the component mounted on a high effective thermal conductivity 4-layer board of JEDEC-51-7. The thermal resistance greatly varies with layout, copper thickness, number of layers and PCB size.

## Recommended Operating Conditions

- VIN Supply Voltage ----- +2V to +5.5V
- Output Current ( $I_{OUT}$ ) ----- 0mA to 300mA
- Operating Temperature Range ( $T_{OPR}$ ) ----- -40°C to +85°C
- Operating Junction Temperature Range ( $T_J$ ) ----- -40°C to +125°C

## Electrical Characteristics

( $V_{IN}=V_{OUT}+1V$ ,  $\overline{SHDN}$  pin connected to  $V_{IN}$ ,  $C_{IN}=1\mu F$ ,  $C_{OUT}=1\mu F$ ,  $T_A=25^\circ C$ , unless otherwise specified)

Parameter	Symbol	Conditions	Min	Typ	Max	Unit	
Input Voltage Range	$V_{IN}$		2		5.5	V	
Current Limit	$I_{LIMIT}$	$R_{Load}=1\Omega$	300			mA	
Quiescent Current	$I_Q$	$I_{OUT}=0mA$		35		$\mu A$	
Standby Current	$I_{STBY}$	$\overline{SHDN}$ Pin Connected to GND		0.1	1	$\mu A$	
Output Voltage Accuracy	$\Delta V_{OUT}$	$I_{OUT}=1mA$	-2		+2	%	
Dropout Voltage <sup>(Note 4)</sup>	$V_{DROP}$	$I_{OUT}=300mA$	$V_{OUT}=1.2V$		1950	2300	mV
			$V_{OUT}=1.5V$		1600	1920	
			$V_{OUT}=1.8V$		1450	1750	
			$V_{OUT}=2.5V$		980	1170	
			$V_{OUT}=2.7V$		630	760	
			$V_{OUT}=3.0V$		510	610	
			$V_{OUT}=3.3V$		400	480	
Dropout Voltage <sup>(Note 4)</sup>	$V_{DROP}$	$I_{OUT}=100mA$	$V_{OUT}=1.2V$		650	767	mV
			$V_{OUT}=1.5V$		533	640	
			$V_{OUT}=1.8V$		483	583	
			$V_{OUT}=2.5V$		327	390	
			$V_{OUT}=2.7V$		210	253	
			$V_{OUT}=3.0V$		170	203	
			$V_{OUT}=3.3V$		133	160	
Line Regulation	$\Delta V_{LINE}$	$I_{OUT}=1mA$ , $V_{IN}=V_{OUT}+1V$ to 5V		1	8	mV	
Load Regulation <sup>(Note 5)</sup>	$\Delta V_{LOAD}$	$I_{OUT}=0mA$ to 150mA		6	30	mV	
Ripple Rejection <sup>(Note 6)</sup>	PSRR	$V_{IN}=V_{OUT}+1V$ , $f_{RIPPLE} = 10kHz$		70		dB	
Output Noise Voltage <sup>(Note 6)</sup>	$V_{NOISE}$	$C_{OUT}=1\mu F$ , $I_{OUT}=0mA$ $BW=10Hz \sim 100kHz$		65		$\mu V_{RMS}$	
Temperature Coefficient <sup>(Note 6)</sup>	TC	$I_{OUT}=1mA$ , $V_{IN}=5V$		100		ppm/ $^\circ C$	
Thermal Shutdown Threshold <sup>(Note 6)</sup>	$T_{SD}$			145		$^\circ C$	
	$\Delta T_{SD}$	Hysteresis		25		$^\circ C$	
$\overline{SHDN}$ Pin Current	$I_{\overline{SHDN}}$			0.3		$\mu A$	
$\overline{SHDN}$ Pin Threshold	$V_{\overline{SHDN}(ON)}$	Start-up	1.0			V	
	$V_{\overline{SHDN}(OFF)}$	Shutdown			0.4	V	

Note 4: The dropout voltage is defined as  $V_{IN}-V_{OUT}$ , which is measured when  $V_{OUT}$  drops 2% of its normal value with the specified output current.

Note 5: Load regulation and dropout voltage are measured at a constant junction temperature by using a 40ms low duty cycle current pulse.

Note 6: Guarantee by design.

## Application Information

The FP6185 is a low dropout linear regulator that could provide 300mA output current at dropout voltage about 400mV. Current limit and on chip thermal shutdown features provide protection against any combination of overload or ambient temperature that could exceed maximum junction temperature.

### 1. Output and Input Capacitor

The FP6185 regulator is designed to be stable with a wide range of output capacitors. The ESR of the output capacitor affects stability. Larger value of the output capacitor decreases the peak deviations and improves transient response for larger current changes.

The capacitor types (aluminum, ceramic, and tantalum) have different characterizations such as temperature and voltage coefficients. All ceramic capacitors are manufactured with a variety of dielectrics, each with different behavior across temperature and applications. Common dielectrics used are X5R, X7R and Y5V. It is recommended to use 1 $\mu$ F to 10 $\mu$ F X5R or X7R dielectric ceramic capacitors with 30m $\Omega$  to 50m $\Omega$  ESR range between device outputs and ground for stability. The FP6185 is designed to be stable with low ESR ceramic capacitors and higher values of capacitors and ESR could improve output stability. The ESR of output capacitor is very important because it generates a zero to provide phase lead for loop stability.

There are no requirements for the ESR on the input capacitor, but its voltage and temperature coefficient have to be considered for device application environment.

### 2. Protection Features

In order to prevent overloading or thermal condition from damaging the device, FP6185 has internal thermal and current limiting functions designed to protect the device. It will rapidly shut off PMOS pass element during over-temperature condition.

### 3. Thermal Consideration

The power handling capability of the device will be limited by allowable operation junction temperature (125°C). The power dissipated by the device will be estimated by  $P_D = I_{OUT} \times (V_{IN} - V_{OUT})$ . The power dissipation should be lower than the maximum power dissipation listed in "Absolute Maximum Ratings" section.

### 4. Shutdown Operation

The FP6185 is shutdown by pulling the  $\overline{\text{SHDN}}$  input low, and turned on by driving the  $\overline{\text{SHDN}}$  high. If  $\overline{\text{SHDN}}$  pin floating, the FP6185 will shut down because  $\overline{\text{SHDN}}$  pin has built-in a pull low resistor (refer to Block Diagram).

Outline Information

SOT-23-5 Package (Unit: mm)

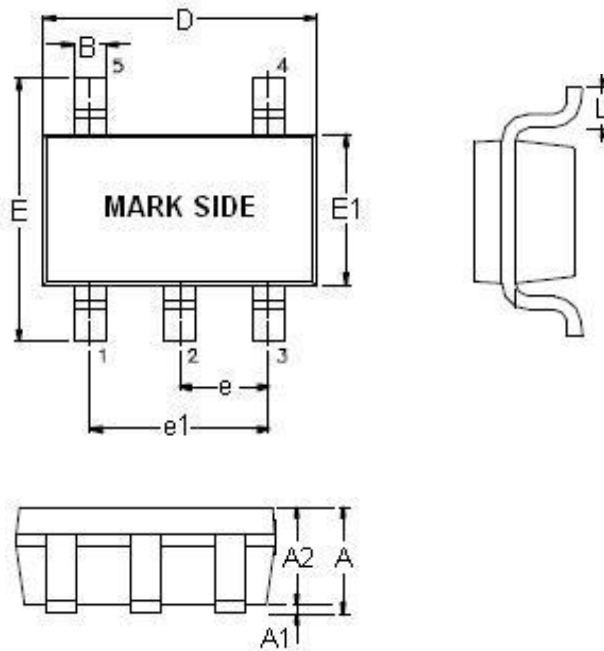

SYMBOLS UNIT	DIMENSION IN MILLIMETER	
	MIN	MAX
A	0.90	1.45
A1	0.00	0.15
A2	0.90	1.30
B	0.30	0.50
D	2.80	3.00
E	2.60	3.00
E1	1.50	1.70
e	0.90	1.00
e1	1.80	2.00
L	0.30	0.60

Note : Followed From JEDEC MO-178-C.

Carrier Dimensions

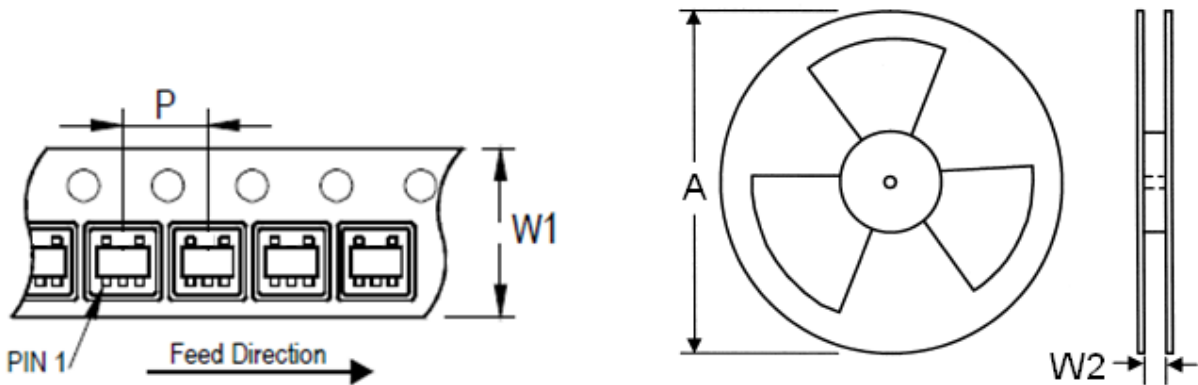

Tape Size (W1) mm	Pocket Pitch (P) mm	Reel Size (A)		Reel Width (W2) mm	Empty Cavity Length mm	Units per Reel
		in	mm			
8	4	7	180	8.4	300~1000	3,000

Outline Information (Continued)

UTDFN- 4L 1.0mm x 1.0mm (pitch 0.65 mm) Package (Unit: mm)

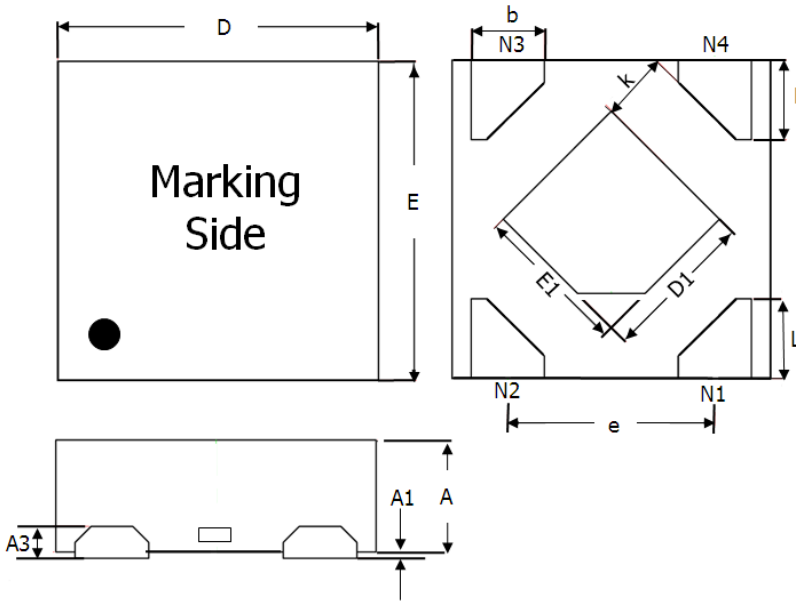

SYMBOLS UNIT	DIMENSION IN MILLIMETER	
	MIN	MAX
A	0.340	0.400
A1	0.00	0.050
A3	0.102REF	
D	0.950	1.050
E	0.950	1.050
D1	0.430	0.530
E1	0.430	0.530
k	0.211REF	
b	0.180	0.280
e	0.650TYP	
L	0.200	0.300

Note : Followed From JEDEC 664-1

Carrier Dimensions

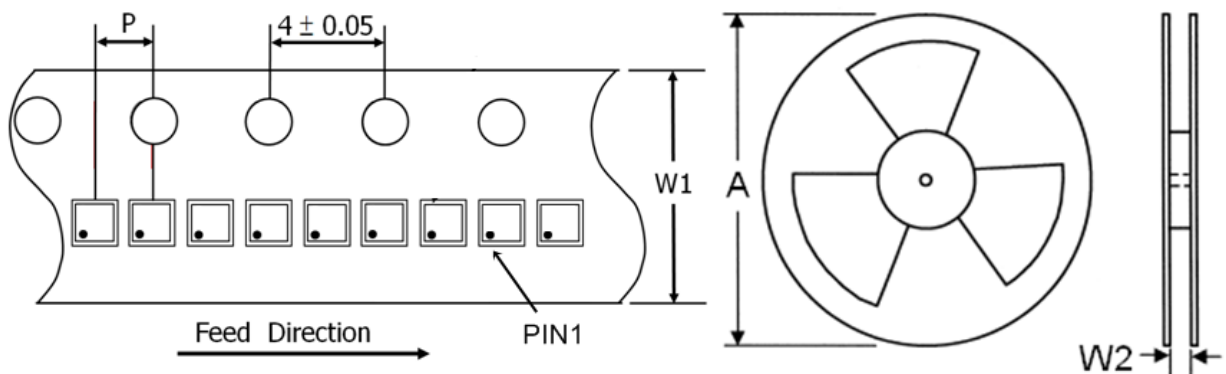

Tape Size (W1) mm	Pocket Pitch (P) mm	Reel Size (A)		Reel Width (W2) mm	Empty Cavity Length mm	Units per Reel
		in	mm			
8	2	7	180	9.5	400~1000	10,000

Life Support Policy

Fitipower's products are not authorized for use as critical components in life support devices or other medical systems.

## X-ON Electronics

Largest Supplier of Electrical and Electronic Components

*Click to view similar products for [LDO Voltage Regulators](#) category:*

*Click to view products by [Fitipower](#) manufacturer:*

Other Similar products are found below :

[M38D29FFHP#U1](#) [702103A](#) [717726C](#) [742457H](#) [MP20051DN-LF-Z](#) [R5F111PGGFB#30](#) [AP7363-SP-13](#) [NCP103AMX285TCG](#)  
[NCV8664CST33T3G](#) [NCV8752AMX28TCG](#) [L9454](#) [AP7362-HA-7](#) [LX13043CLD](#) [TCR3DF185,LM\(CT](#) [TCR3DF24,LM\(CT](#)  
[TCR3DF285,LM\(CT](#) [TCR3DF31,LM\(CT](#) [TCR3DF45,LM\(CT](#) [TLF4949EJ](#) [L9708](#) [L970813TR](#) [030014BB](#) [059985X](#) [EAN61387601](#)  
[EAN61573601](#) [NCP121AMX173TCG](#) [NCP4687DH15T1G](#) [NCV8703MX30TCG](#) [701326R](#) [702087BB](#) [755078E](#) [TCR2EN28,LF\(S](#)  
[LM1117DT-1.8/NO](#) [LT1086CM#TRPBF](#) [AZ1085S2-1.5TRE1](#) [MAX15101EWL+T](#) [NCV8170AXV250T2G](#) [SCD337BTG](#)  
[TCR3DF27,LM\(CT](#) [TCR3DF19,LM\(CT](#) [TCR3DF125,LM\(CT](#) [TCR2EN18,LF\(S](#) [MAX15103EWL+T](#) [TS2937CZ-5.0 C0](#) [MAX8878EUK30-](#)  
[T](#) [MAX663CPA](#) [NCV4269CPD50R2G](#) [NCV8716MT30TBG](#) [AZ1117IH-1.2TRG1](#) [MP2013GQ-P](#)