



*Classic LCDs & LEDs*

# **LCD MODULE**

## **COB(Chip On Board) SERIES**

**On - line catalogue ( V6.0 )  
www.fordata.cn**



ITEM NUMBER	DISPLAY FORMAT	OVERALL SIZE
FDCC0801A	8CHR. X 1LINE	84.0X44.0
<b>FDCC0801B</b>	8CHR. X 1LINE	69.0X27.0
FDCC0802B	8CHR. X 2LINES	58.0X32.0
FDCC0802C	8CHR. X 2LINES	40.0X35.4
FDCC1601A	16CHR. X 1LINE	151.0X40.0
FDCC1601B	16CHR. X 1LINE	122.0X33.0

Click the item number in the list to get to the right page of products.

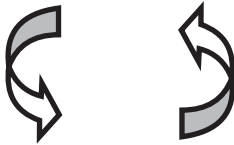

Click the logo on the up-left corner of each page to return.



Print out the PDF pages.

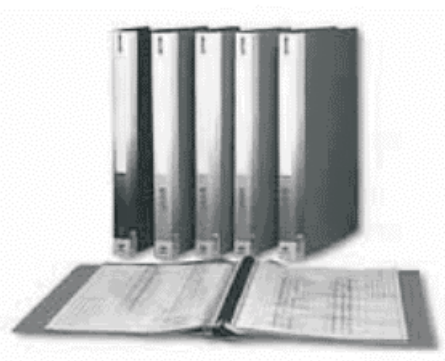

Load the printed pages into the document bags for a complete catalogue



1	2	3	4	5	6	—	7	8	9	10	11	12	—	13	14	15	16
F	C	08	01	A	23	—	F	S	Y	Y	B	W	—	5	2	L	E

No.	REMARKS	DESCRIPTION				
1	COMPANY ABBRAVIATED	F = FORDATA				
2	STANDARD MODULE TYPE	C = Character type standard LCD module (COB version) G = Graphic type standard LCD module (COB version)				
3	Character (FC series)	08, 10, 12, 16, 20, 24, 40, = Character number Per line				
	Graphic (FG series)	80, 100, 120, 122, 128, 160 ... .. = Row Dots Quantity				
4	Character (FC series)	01, 02, 04, = Character Lines				
	Graphic (FG series)	32, 64, 80, 128, 160 ... .. =Column Dots Quantity				
5	Serial Number	A~Z which is decided by the sizes of viewing area				
6	Identifying Code	00~99 which is decided by all the other aspects for the same viewing area				
7	Polarizer type	R = Positive Reflective M = Positive Transmissive B = Super Black technology <i>New!</i> F = Positive Transflective N = Negative Transmissive				
8	Backlight type	N = No Backlight S = Edge Type LED Backlight (Standard version) H = Edge Type LED Backlight (Long life span version) <i>New!</i> E = EL backlight without Invertor C = CCFL backlight without Invertor L = Array Type LED Backlight F = EL backlight with Invertor T = CCFL backlight with Invertor				
9	Backlight color	N = No Backlight R = Red B = Blue Y = Yellow-Green A = Amber G = Green W = White C = Blue-Green Q = RedGreenBlue three color <i>New!</i>				
10	LCD panel type	T = TN G = Gray STN H = HTN B = Blue STN Y = Yellow-Green STN F = FSTN				
11	Viewing angle	B = Bottom 6:00 T = Top 12:00 R = Right 3:00 L = Left 9:00				
12	Operation temperature range	S = 0°C ~ 50°C (Single Supply Voltage) W = -20°C ~ 70°C (Single Supply Voltage) T = -30°C ~ 80°C (Single Supply Voltage) D = 0°C ~ 50°C (Dual Supply Voltage) H = -20°C ~ 70°C (Dual Supply Voltage) E = -30°C ~ 80°C (Dual Supply Voltage)				
13	Driving Voltage Code (This code was updated from 2015-JAN-1ST)		Vlcm=3. 0V	Vlcm=3. 3V	Vlcm=3. 6V	Vlcm=5.0V
		Vled=3. 0V	9	A	3	4
		Vled=3. 3V	T	B	K	F
		Vled=4. 2V	9	A	3	4
		Vled=5. 0V	8	C	2	5
		NO/EL/CCFL	1	N	7	6
14	Backlight Connect Method	0 = PIN1 LED-, PIN2 LED+ 1 = PIN15(17/19) LED+, PIN16(18/20) LED- 2 = PIN15(17/19) LED-, PIN16(18/20) LED+ 3 = PIN15(17/19) LED+, PIN16(18/20) NC 4 = PIN15(17/19) NC, PIN16(18/20) LED+ 5 = PINA LED+, PINK LED- 6 = No / EL / CCFL Backlight				
15	IC Manufacturer Code	A~Z or 01~99 which is decided by different IC manufacturers				
16	Font Set	A~Z or 01~99 which is decided by different font maps				



**CHARACTER TYPE LCD MODULE**

ITEM NUMBER	DISPLAY FORMAT	OVERALL SIZE	VIEWING AREA	HOLE-HOLE	CHARACTER SIZE	DOT SIZE	DUTY
FDCC0801A	8CHR. X 1LINE	84.0X44.0	61.0X15.8	79.0X36.0	6.45X10.75	1.25X1.30	1/8
FDCC0801B	8CHR. X 1LINE	69.0X27.0	45.2X13.8	65.40	4.20X7.71	0.80X0.92	1/8
FDCC0802B	8CHR. X 2LINES	58.0X32.0	38.0X16.0	53.0X27.0	2.96X5.56	0.56X0.66	1/16
FDCC0802C	8CHR. X 2LINES	40.0X35.4	30.4X13.9	36.0X30.9	2.95X4.75	0.55X0.55	1/16
FDCC1601A	16CHR. X 1LINE	151.0X40.0	120.0X23.0	143.0X32.0	6.00X14.54	1.152X1.765	1/16
FDCC1601B	16CHR. X 1LINE	122.0X33.0	99.0X13.0	115.0X25.0	4.84X9.22	0.92X1.10	1/16
FDCC1601E	16CHR. X 1LINE	80.0X36.0	64.0X13.8	75.0X31.0	3.07X6.56	0.55X0.75	1/16
FDCC1602A	16CHR. X 2LINES	122.0X44.0	99.0X24.0	115.0X37.0	5.20X9.55	1.00X1.15	1/16
FECC1602B	16CHR. X 2LINES	85.0X36.0	63.0X16.4	80.0X31.0	3.00X5.23	0.56X0.61	1/16
FECC1602C	16CHR. X 2LINES	85.0X32.6	64.5X16.4	79.0X29.2	3.00X5.23	0.56X0.61	1/16
FECC1602D	16CHR. X 2LINES	85.0X29.5	64.5X16.4	81.0X24.0	3.00X5.23	0.56X0.61	1/16
FECC1602E	16CHR. X 2LINES	84.0X44.0	64.5X16.4	79/76X36.0	3.00X5.23	0.56X0.61	1/16
FECC1602G	16CHR. X 2LINES	80.0X36.0	64.5X16.4	75.0X31.0	3.00X5.23	0.56X0.61	1/16
FDCC1602L	16CHR. X 2LINES	65.5X36.7	54.0X14.4	60.5X31.7	2.55X4.99	0.47X0.58	1/16
FDCC1602N	16CHR. X 2LINES	80.0X36.0	64.0X13.8	75.0X31.0	2.95X4.35	0.55X0.50	1/16
FDCC1602P	16CHR. X 2LINES	122.0X44.0	99.0X24.0	115.0X37.0	4.84X9.66	0.92X1.10	1/16
FDCC1604A	16CHR. X 4LINES	87.0X60.0	61.8X25.2	82.0X55.0	2.95X4.75	0.55X0.55	1/16
FDCC2002C	20CHR. X 2LINES	146.0X43.0	123.0X23.0	139.0X36.0	4.84X9.22	0.92X1.10	1/16
FDCC2002D	20CHR. X 2LINES	116.0X37.0	83.0X18.6	108.0X29.0	3.20X5.95	0.60X0.65	1/16
FDCC2004B	20CHR. X 4LINES	98.0X60.0	76.0X25.2	93.0X55.0	2.95X4.75	0.55X0.55	1/16
FDCC2004C	20CHR. X 4LINES	77.0X47.0	60.0X22.0	70.0X40.0	2.30X4.03	0.42X0.46	1/16
FDCC2004D	20CHR. X 4LINES	146.0X62.5	123.0X42.5	139.0X55.5	4.84X9.22	0.92X1.10	1/16
FDCC2004F	20CHR. X 4LINES	98.0X60.0	76.0X26.0	93.0X55.0	2.95X4.75	0.55X0.55	1/16
FDCC2402E	24CHR. X 2LINES	116.0X37.0	83.0X18.6	108.0X29.0	2.70X5.55	0.50X0.65	1/16
FDCC4002B	40CHR. X 2LINES	182.0X33.5	152.5X16.5	175.0X26.5	3.20X5.55	0.60X0.65	1/16
FDCC4004A	40CHR. X 4LINES	190.0X54.0	147.0X29.5	183.0X47.0	2.78X4.89	0.50X0.55	1/16

**GRAPHIC TYPE LCD MODULE**

ITEM NUMBER	DISPLAY FORMAT	MODULE SIZE	VIEWING AREA	HOLE-HOLE	DOT SIZE	DUTY	CONTROLLER
FDCG12232D	122X32 Dot Matrix	84.0X44.0	64.0X17.9	79.5/76.0X36.0	0.40X0.45	1/32	SED1520D0A
FDCG12232G	122X32 Dot Matrix	84.0X44.0	64.0X17.9	76.0X36.0	0.40X0.45	1/32	SED1520DAA
FDCG12864B	128X64 Dot Matrix	93.0X70.0	72.0X40.0	88.0X64.0	0.48X0.48	1/64	KS0108B
FDCG12864E	128X64 Dot Matrix	78.0X70.0	62.0X44.0	68.0X65.0	0.40X0.56	1/64	KS0108B
FDCG12864G	128X64 Dot Matrix	87.0X71.0	62.0X44.0	75.0X67.0	0.40X0.56	1/64	KS0108B
FDCG12864H	128X64 Dot Matrix	75.0X52.7	60.0X32.5	70.0X49.7	0.39X0.39	1/64	KS0108B
FDCG12864K	128X64 Dot Matrix	78.0X70.0	62.0X44.0	68.0X65.0	0.40X0.56	1/64	T6963C
FDCG12864N	128X64 Dot Matrix	75.0X52.7	60.0X32.5	70.0X49.7	0.39X0.39	1/64	T6963C
FECG24064B	240X64 Dot Matrix	180.0X65.0	134.0X40.4	176.0X54.0	0.49X0.49	1/64	T6963C
FDCG128128A	128X128 Dot Matrix	92.0X106.0	73.0X73.0	85.0X99.0	0.50X0.50	1/128	T6963C
FECG240128A	240X128 Dot Matrix	144.0X104.0	114.0X64.0	138.0X97.0	0.40X0.40	1/128	T6963C

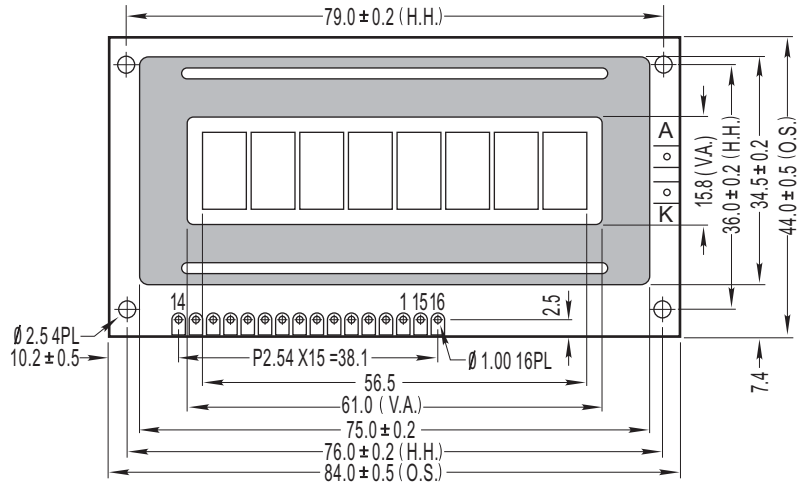
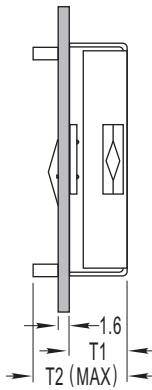

\* O.S.=Overall Size  
 \* V.A.=Viewing Area  
 \* H.H.=Hole-Hole

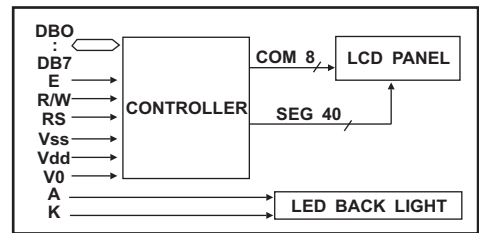
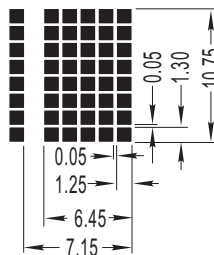

ITEM	T1	T2	UNIT
LED backlight	8.6	13.5	mm
EL or without backlight	4.7	10.0	mm

**FEATURE**

1. 5X8 dots with cursor
2. Built-in controller (SPLC780D or Equivalent)
3. +5V power supply (Also available for +3.0V)
4. 1/8 duty cycle
5. BKL to be driven by pin1, pin2, or pin15, pin16 or A, K
6. N.V. Optional

**ABSOLUTE MAXIMUM RATINGS**

ITEM	SYMBOL	MIN	MAX	UNIT
POWER SUPPLY (LOGIC)	Vdd	-0.3	7.0	V
POWER SUPPLY (LCD)	V0	Vdd-13.5	Vdd+0.3	V
INPUT VOLTAGE	Vin	-0.3	Vdd+0.3	V

**PIN ASSIGNMENT**

PIN	SYMBOL	FUNCTION
1	Vss	GND
2	Vdd	Power Supply
3	V0	Contrast Adjust
4	RS	Register Select Signal
5	R/W	Data Read/Write
6	E	Enable Signal
7-14	DB0-DB7	Data Bus Line
15(A)	LED+	Power supply for BKL(+)
16(K)	LED-	Power supply for BKL(-)

**MECHANICAL SPECIFICATIONS**

CHARACTER NUMBER	8W X 1H	—
OVERALL SIZE	84.00W X 44.00H	mm
VIEWING AREA	61.00W X 15.80H	mm
HOLE - HOLE	79.00W X 36.00H	mm
CHARACTER SIZE	6.45W X 10.75H	mm
CHARACTER PITCH	0.70W	mm
DOT SIZE	1.25W X 1.30H	mm
DOT PITCH	0.05W X 0.05H	mm

**ELECTRONICAL CHARACTERISTICS**

ITEM	SYMBOL	CONDITION	STANDARD			UNIT
			MIN	TYP	MAX	
Input voltage	Vdd	+5V	4.7	5.0	5.5	V
		+3.3V	2.7	3.0	3.3	V
Supply current	Idd	Vdd=5V	---	1.3	2.5	mA
Recommended LCD driving voltage for normal temp version module	Vdd-V0	0 °C	4.7	5.0	5.5	V
		25 °C	4.3	4.5	4.7	
		50 °C	4.1	4.3	4.5	
LED forward voltage	V <sub>F</sub>	25 °C	---	4.2	4.6	V
LED forward current	I <sub>F</sub>	25 °C	---	70	---	mA
EL power supply current	EL	AC 400Hz V <sub>EL</sub> =110V	----	---	---	mA

**DISPLAY CHARACTER ADDRESS CODE**

Display position 1 2 3 4 5 6 7 8  
 DDRAM address 00 01 02 -- -- -- 07

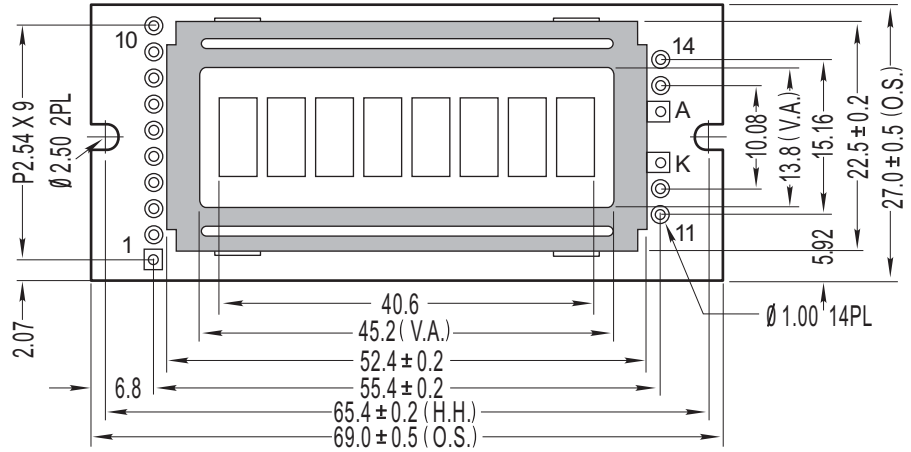
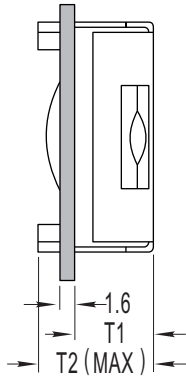

\* O.S.=Overall Size  
 \* V.A.=Viewing Area  
 \* H.H.=Hole-Hole

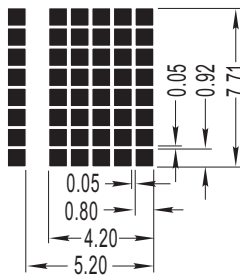

ITEM	T1	T2	UNIT
LED backlight	8.6	13.0	mm
EL or without backlight	4.0	8.0	mm

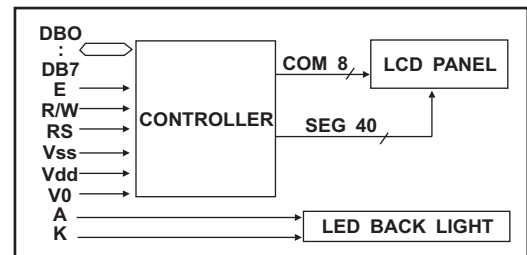

**FEATURE**

- 5X8 dots with cursor
- Built-in controller (SPLC780D or Equivalent)
- +5V power supply (Also available for +3.0V)
- 1/8 duty cycle
- BKL to be driven by pin1, pin2 or A, K
- N.V. Optional

**MECHANICAL SPECIFICATIONS**

CHARACTER NUMBER	8W X 1H	—
OVERALL SIZE	69.00W X 27.00H	mm
VIEWING AREA	45.20W X 13.80H	mm
HOLE - HOLE	65.40W	mm
CHARACTER SIZE	4.20W X 7.71H	mm
CHARACTER PITCH	1.00W	mm
DOT SIZE	0.80W X 0.92H	mm
DOT PITCH	0.05W X 0.05H	mm

**ABSOLUTE MAXIMUM RATINGS**

ITEM	SYMBOL	MIN	MAX	UNIT
POWER SUPPLY (LOGIC)	Vdd	-0.3	7.0	V
POWER SUPPLY (LCD)	V0	Vdd-13.5	Vdd+0.3	V
INPUT VOLTAGE	Vin	-0.3	Vdd+0.3	V

**ELECTRONICAL CHARACTERISTICS**

ITEM	SYMBOL	CONDITION	STANDARD			UNIT
			MIN	TYP	MAX	
Input voltage	Vdd	+5V	4.7	5.0	5.5	V
		+3.3V	2.7	3.0	3.3	V
Supply current	Idd	Vdd=5V	---	1.3	2.5	mA
Recommended LCD driving voltage for normal temp version module	Vdd-V0	0 °C	4.7	5.0	5.5	V
		25 °C	4.3	4.5	4.7	
		50 °C	4.1	4.3	4.5	
LED forward voltage	V <sub>F</sub>	25 °C	---	4.2	4.6	V
LED forward current	I <sub>F</sub>	25 °C	---	70	---	mA
EL power supply current	EL	AC 400Hz V <sub>EL</sub> =110V	----	---	---	mA

**PIN ASSIGNMENT**

PIN	SYMBOL	FUNCTION
1	Vss	GND
2	Vdd	Power Supply
3	V0	Contrast Adjust
4	RS	Register Select Signal
5	R/W	Data Read/Write
6	E	Enable Signal
7-14	DB0-DB7	Data Bus Line
A	LED+	Power supply for BKL(+)
K	LED-	Power supply for BKL(-)

**DISPLAY CHARACTER ADDRESS CODE**

Display position 1 2 3 4 5 6 7 8  
 DDRAM address 00 01 02 -- -- -- 07

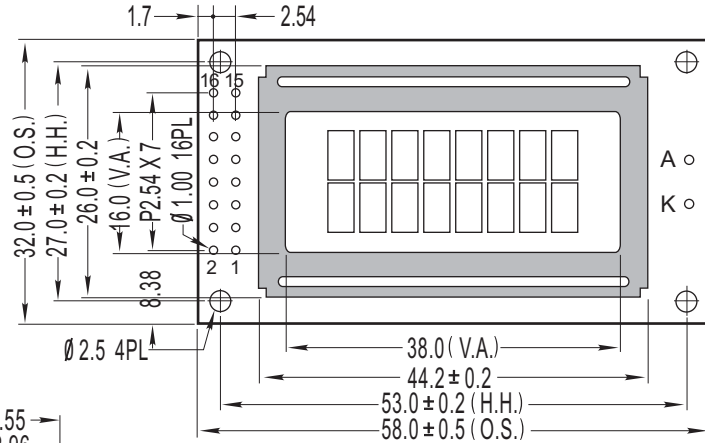
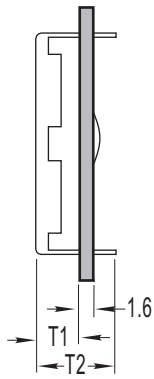

\* O.S.=Overall Size  
 \* V.A.=Viewing Area  
 \* H.H.=Hole -Hole

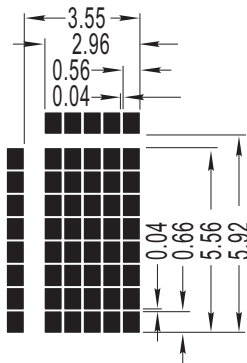

ITEM	T1	T2	UNIT
LED backlight	9.2	13.5	mm
EL or without backlight	5.2	9.5	mm

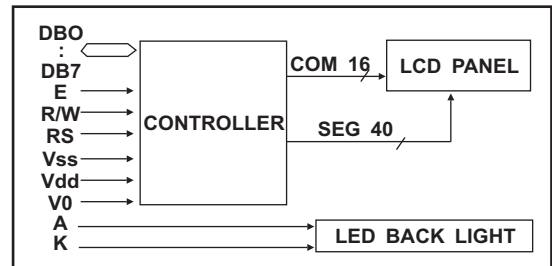

**FEATURE**

1. 5X8 dots with cursor
2. Built-in controller (SPLC780D or Equivalent)
3. +5V power supply (Also available for +3.0V)
4. 1/16 duty cycle
5. BKL to be driven by pin1, pin2 or A,K
6. N.V. Optional

**ABSOLUTE MAXIMUM RATINGS**

ITEM	SYMBOL	MIN	MAX	UNIT
POWER SUPPLY (LOGIC)	Vdd	-0.3	7.0	V
POWER SUPPLY (LCD)	V0	Vdd-13.5	Vdd+0.3	V
INPUT VOLTAGE	Vin	-0.3	Vdd+0.3	V

**PIN ASSIGNMENT**

PIN	SYMBOL	FUNCTION
1	Vss	GND
2	Vdd	Power Supply
3	V0	Contrast Adjust
4	RS	Register Select Signal
5	R/W	Data Read/Write
6	E	Enable Signal
7-14	DB0-DB7	Data Bus Line
A	LED+	Power supply for BKL(+)
K	LED-	Power supply for BKL(-)

**MECHANICAL SPECIFICATIONS**

CHARACTER NUMBER	8W X 2H	—
OVERALL SIZE	58.00W X 32.00H	mm
VIEWING AREA	38.00W X 16.00H	mm
HOLE - HOLE	53.00WX27.00H	mm
CHARACTER SIZE	2.96W X 5.56H	mm
CHARACTER PITCH	0.59WX0.36H	mm
DOT SIZE	0.56W X 0.66H	mm
DOT PITCH	0.04W X 0.04H	mm

**ELECTRONICAL CHARACTERISTICS**

ITEM	SYMBOL	CONDITION	STANDARD			UNIT
			MIN	TYP	MAX	
Input voltage	Vdd	+5V	4.7	5.0	5.5	V
		+3.3V	2.7	3.0	3.3	V
Supply current	Idd	Vdd=5V	---	1.3	2.5	mA
Recommended LCD driving voltage for normal temp version module	Vdd-V0	0 °C	4.7	5.0	5.5	V
		25 °C	4.3	4.5	4.7	
		50 °C	4.1	4.3	4.5	
LED forward voltage	V <sub>F</sub>	25 °C	---	4.2	4.6	V
LED forward current	I <sub>F</sub>	25 °C	---	70	---	mA
EL power supply current	EL	AC 400Hz V <sub>EL</sub> =110V	----	---	---	mA

**DISPLAY CHARACTER ADDRESS CODE**

Display position	1 2 3 4 5 6 7 8
DDRAM address	00 01 02 -- -- -- 07
DDRAM address	40 41 42 -- -- -- 47

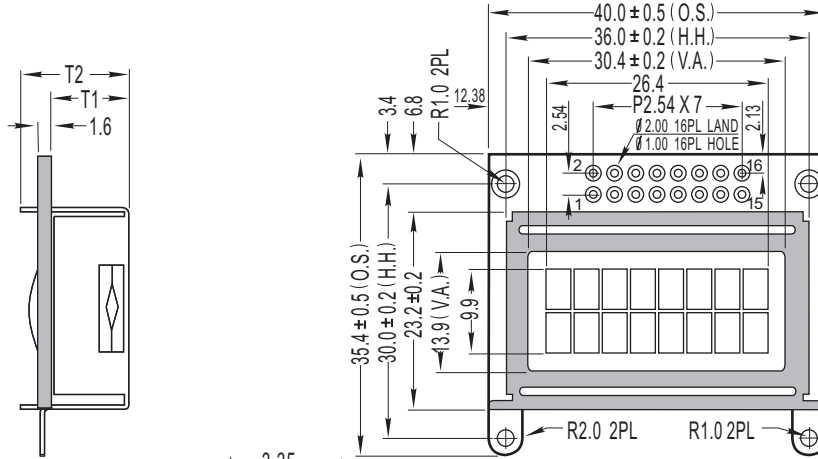

\* O.S.=Overall Size  
 \* V.A.=Viewing Area  
 \* H.H.=Hole -Hole

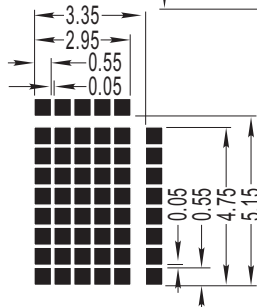

ITEM	T1	T2	UNIT
LED backlight	9.0	13.0	mm
EL or without backlight	3.7	8.5	mm

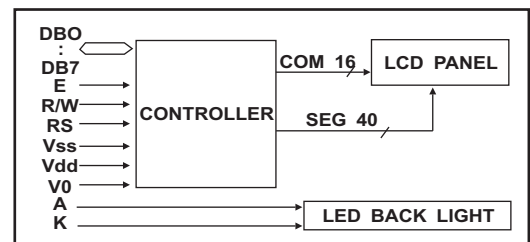

**FEATURE**

1. 5X8 dots with cursor
2. Built-in controller (SPLC780D or Equivalent)
3. +5V power supply (Also available for +3.0V)
4. 1/16 duty cycle
5. BKL to be driven by pin15, pin16
6. N.V. Optional

**ABSOLUTE MAXIMUM RATINGS**

ITEM	SYMBOL	MIN	MAX	UNIT
POWER SUPPLY (LOGIC)	Vdd	-0.3	7.0	V
POWER SUPPLY (LCD)	V0	Vdd-13.5	Vdd+0.3	V
INPUT VOLTAGE	Vin	-0.3	Vdd+0.3	V

**PIN ASSIGNMENT**

PIN	SYMBOL	FUNCTION
1	Vss	GND
2	Vdd	Power Supply
3	V0	Contrast Adjust
4	RS	Register Select Signal
5	R/W	Data Read/Write
6	E	Enable Signal
7-14	DB0-DB7	Data Bus Line
15	LED+	Power supply for BKL(+)
16	LED-	Power supply for BKL(-)

**MECHANICAL SPECIFICATIONS**

CHARACTER NUMBER	8W X 2H	—
OVERALL SIZE	40.00W X 35.40H	mm
VIEWING AREA	30.40W X 13.90H	mm
HOLE - HOLE	36.00WX30.90H	mm
CHARACTER SIZE	2.95W X 4.75H	mm
CHARACTER PITCH	0.40WX0.40H	mm
DOT SIZE	0.55W X 0.55H	mm
DOT PITCH	0.05W X 0.05H	mm

**ELECTRONICAL CHARACTERISTICS**

ITEM	SYMBOL	CONDITION	STANDARD			UNIT
			MIN	TYP	MAX	
Input voltage	Vdd	+5V	4.7	5.0	5.5	V
		+3.3V	2.7	3.0	3.3	V
Supply current	Idd	Vdd=5V	---	1.3	2.5	mA
		Recommended LCD driving voltage for normal temp version module	0 °C	4.7	5.0	5.5
		25 °C	4.3	4.5	4.7	
		50 °C	4.1	4.3	4.5	
LED forward voltage	V <sub>F</sub>	25 °C	---	4.2	4.6	V
LED forward current	I <sub>F</sub>	25 °C	---	70	---	mA
EL power supply current	EL	AC 400Hz V <sub>EL</sub> =110V	----	---	---	mA

**DISPLAY CHARACTER ADDRESS CODE**

Display position	1 2 3 4 5 6 7 8
DDRAM address	00 01 02 -- -- -- 07
DDRAM address	40 41 42 -- -- -- 47



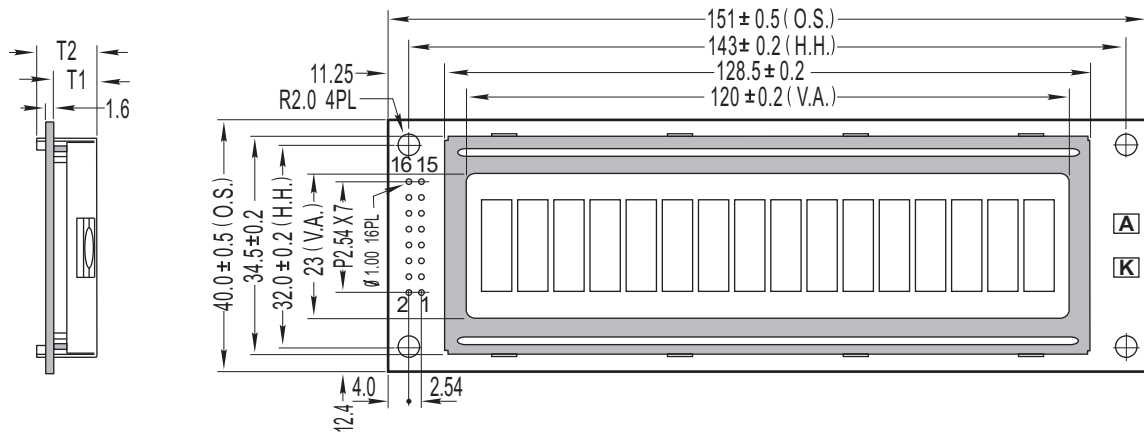

\* O.S.=Overall Size  
 \* V.A.=Viewing Area  
 \* H.H.=Hole-Hole

ITEM	T1	T2	UNIT
LED backlight	8.6	13.5	mm
EL or without backlight	5.0	9.5	mm

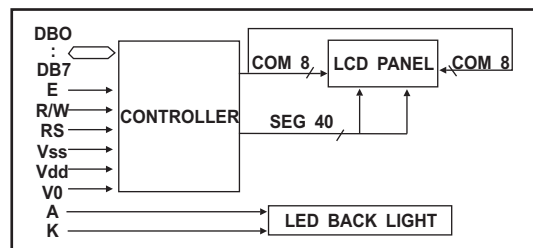
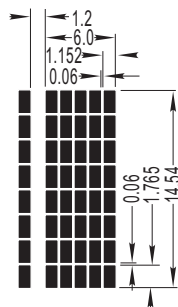

**FEATURE**

1. 5X8 dots with cursor
2. Built-in controller (SPLC780D or Equivalent)
3. +5V power supply (Also available for +3.0V)
4. 1/16 duty cycle
5. BKL to be driven by pin1, pin2, or pin15, pin16 or A, K
6. N.V. Optional

**ABSOLUTE MAXIMUM RATINGS**

ITEM	SYMBOL	MIN	MAX	UNIT
POWER SUPPLY (LOGIC)	Vdd	-0.3	7.0	V
POWER SUPPLY (LCD)	V0	Vdd -13.5	Vdd +0.3	V
INPUT VOLTAGE	Vin	-0.3	Vdd +0.3	V

**PIN ASSIGNMENT**

PIN	SYMBOL	FUNCTION
1	Vss	GND
2	Vdd	Power Supply
3	V0	Contrast Adjust
4	RS	Register Select Signal
5	R/W	Data Read/Write
6	E	Enable Signal
7-14	DB0-DB7	Data Bus Line
15(A)	LED+	Power supply for BKL(+)
16(K)	LED-	Power supply for BKL(-)

**MECHANICAL SPECIFICATIONS**

CHARACTER NUMBER	16W X 1H	—
OVERALL SIZE	151.00W X 40.00H	mm
VIEWING AREA	120.00W X 23.00H	mm
HOLE - HOLE	143.00W X 32.00H	mm
CHARACTER SIZE	6.00W X 14.54H	mm
CHARACTER PITCH	1.20W	mm
DOT SIZE	1.152W X 1.765H	mm
DOT PITCH	0.06W X 0.06H	mm

**ELECTRONICAL CHARACTERISTICS**

ITEM	SYMBOL	CONDITION	STANDARD			UNIT
			MIN	TYP	MAX	
Input voltage	Vdd	+5V	4.7	5.0	5.5	V
		+3.3V	2.7	3.0	3.3	V
Supply current	Idd	Vdd=5V	---	2.0	4.0	mA
Recommended LCD driving voltage for normal temp version module	Vdd-V0	0 °C	4.7	5.0	5.5	V
		25 °C	4.3	4.5	4.7	
		50 °C	4.1	4.3	4.5	
LED forward voltage	V <sub>F</sub>	25 °C	---	4.2	4.6	V
LED forward current	I <sub>F</sub>	25 °C	---	300	---	mA
EL power supply current	EL	AC 400Hz V <sub>EL</sub> =110V	----	---	---	mA

**DISPLAY CHARACTER ADDRESS CODE**

Display position	1	2	3	4	5	6	7	8	9	10	11	12	13	14	15	16
DDRAM address	00	01	02	--	--	--	07	40	41	42	--	--	--	--	--	47

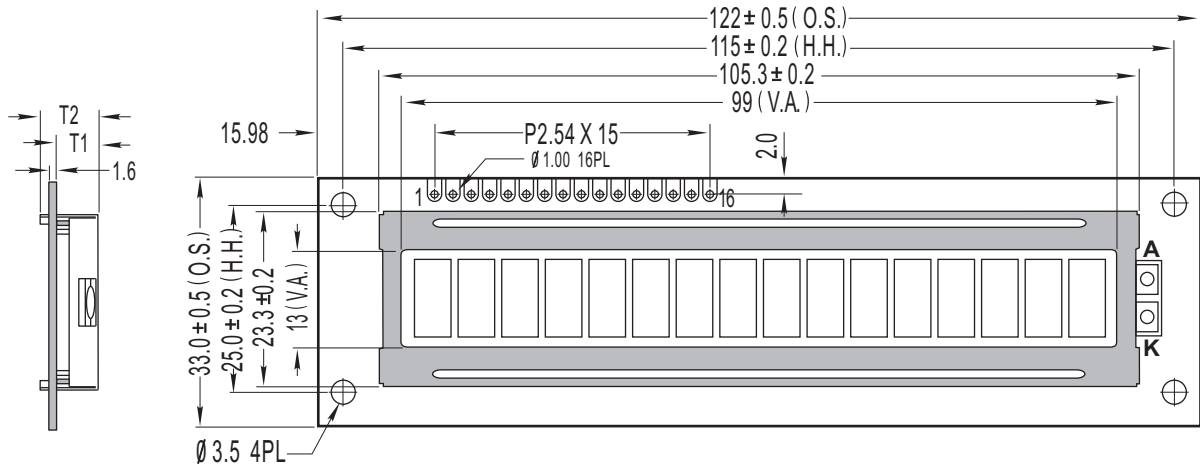

\* O.S.=Overall Size  
 \* V.A.=Viewing Area  
 \* H.H.=Hole -Hole

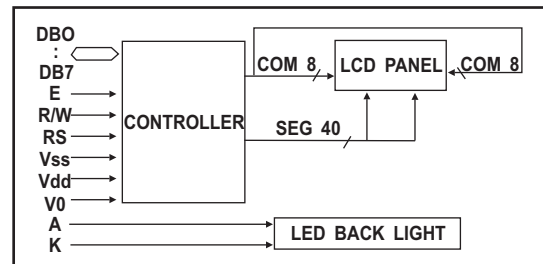
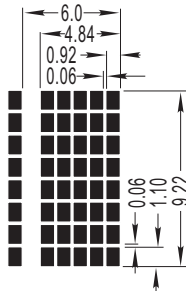

ITEM	T1	T2	UNIT
LED backlight	9.8	15.2	mm
EL or without backlight	4.5	9.5	mm

**FEATURE**

1. 5X8 dots with cursor
2. Built-in controller (SPLC780D or Equivalent)
3. +5V power supply (Also available for +3.0V)
4. 1/16 duty cycle
5. BKL to be driven by pin1, pin2, or pin15, pin16 or A, K
6. N.V. Optional

**MECHANICAL SPECIFICATIONS**

CHARACTER NUMBER	16W X 1H	—
OVERALL SIZE	122.00W X 33.00H	mm
VIEWING AREA	99.00W X 13.00H	mm
HOLE - HOLE	115.00W X 25.00H	mm
CHARACTER SIZE	4.84W X 9.22H	mm
CHARACTER PITCH	1.16W	mm
DOT SIZE	0.92W X 1.10H	mm
DOT PITCH	0.06W X 0.06H	mm

**ABSOLUTE MAXIMUM RATINGS**

ITEM	SYMBOL	MIN	MAX	UNIT
POWER SUPPLY (LOGIC)	Vdd	-0.3	7.0	V
POWER SUPPLY (LCD)	V0	Vdd-13.5	Vdd+0.3	V
INPUT VOLTAGE	Vin	-0.3	Vdd+0.3	V

**ELECTRONICAL CHARACTERISTICS**

ITEM	SYMBOL	CONDITION	STANDARD			UNIT
			MIN	TYP	MAX	
Input voltage	Vdd	+5V	4.7	5.0	5.5	V
		+3.3V	2.7	3.0	3.3	V
Supply current	Idd	Vdd=5V	---	1.5	4.0	mA
		Recommended LCD driving voltage for normal temp version module	0 °C	4.7	5.0	5.5
		25 °C	4.3	4.5	4.7	
		50 °C	4.1	4.3	4.5	
LED forward voltage	V <sub>F</sub>	25 °C	---	4.2	4.6	V
LED forward current	I <sub>F</sub>	25 °C	---	180	---	mA
EL power supply current	EL	AC 400Hz V <sub>EL</sub> =110V	----	---	---	mA

**PIN ASSIGNMENT**

PIN	SYMBOL	FUNCTION
1	Vss	GND
2	Vdd	Power Supply
3	V0	Contrast Adjust
4	RS	Register Select Signal
5	R/W	Data Read/Write
6	E	Enable Signal
7-14	DB0-DB7	Data Bus Line
15(A)	LED+	Power supply for BKL(+)
16(K)	LED-	Power supply for BKL(-)

**DISPLAY CHARACTER ADDRESS CODE**

Display position 1 2 3 4 5 6 7 8 9 10 11 12 13 14 15 16  
 DDRAM address 00 01 02 -- -- -- 07 40 41 42 -- -- -- 47

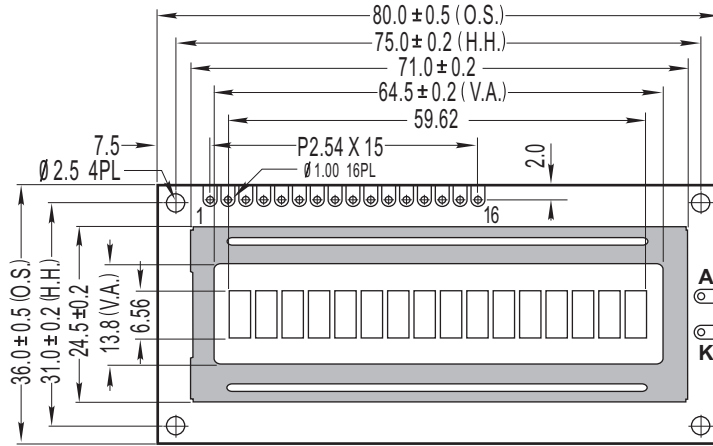
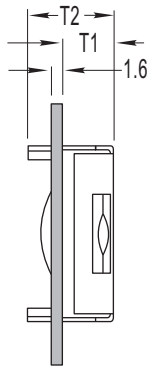

\* O.S.=Overall Size  
 \* V.A.=Viewing Area  
 \* H.H.=Hole-Hole

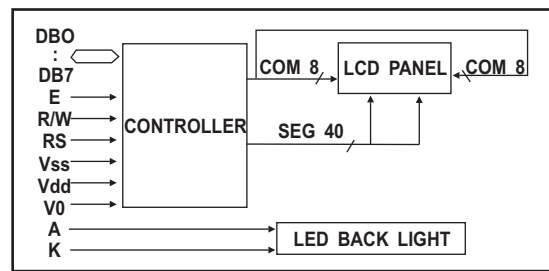
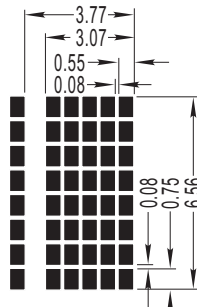

ITEM	T1	T2	UNIT
LED backlight	8.5	13.5	mm
EL or without backlight	4.5	9.5	mm

**FEATURE**

1. 5X8 dots with cursor
2. Built-in controller (SPLC780D or Equivalent)
3. +5V power supply (Also available for +3.0V)
4. 1/16 duty cycle
5. BKL to be driven by pin1, pin2, or pin15, pin16 or A, K
6. N.V. Optional

**MECHANICAL SPECIFICATIONS**

CHARACTER NUMBER	16W X 1H	—
OVERALL SIZE	80.00W X 36.00H	mm
VIEWING AREA	64.00W X 13.80H	mm
HOLE - HOLE	75.00W X 31.00H	mm
CHARACTER SIZE	3.07W X 6.56H	mm
CHARACTER PITCH	0.70W	mm
DOT SIZE	0.55W X 0.75H	mm
DOT PITCH	0.08W X 0.08H	mm

**ABSOLUTE MAXIMUM RATINGS**

ITEM	SYMBOL	MIN	MAX	UNIT
POWER SUPPLY (LOGIC)	Vdd	-0.3	7.0	V
POWER SUPPLY (LCD)	V0	Vdd-13.5	Vdd+0.3	V
INPUT VOLTAGE	Vin	-0.3	Vdd+0.3	V

**ELECTRONICAL CHARACTERISTICS**

ITEM	SYMBOL	CONDITION	STANDARD			UNIT
			MIN	TYP	MAX	
Input voltage	Vdd	+5V	4.7	5.0	5.5	V
		+3.3V	2.7	3.0	3.3	V
Supply current	Idd	Vdd=5V	---	1.3	4.0	mA
Recommended LCD driving voltage for normal temp version module	Vdd-V0	0 °C	4.7	5.0	5.5	V
		25 °C	4.3	4.5	4.7	
		50 °C	4.1	4.3	4.5	
LED forward voltage	V <sub>F</sub>	25 °C	---	4.2	4.6	V
LED forward current	I <sub>F</sub>	25 °C	---	110	---	mA
EL power supply current	EL	AC 400Hz V <sub>EL</sub> =110V	----	---	---	mA

**PIN ASSIGNMENT**

PIN	SYMBOL	FUNCTION
1	Vss	GND
2	Vdd	Power Supply
3	V0	Contrast Adjust
4	RS	Register Select Signal
5	R/W	Data Read/Write
6	E	Enable Signal
7-14	DB0-DB7	Data Bus Line
15(A)	LED+	Power supply for BKL(+)
16(K)	LED-	Power supply for BKL(-)

**DISPLAY CHARACTER ADDRESS CODE**

Display position 1 2 3 4 5 6 7 8 9 10 11 12 13 14 15 16  
 DDRAM address 00 01 02 -- -- -- 07 40 41 42 -- -- -- 47























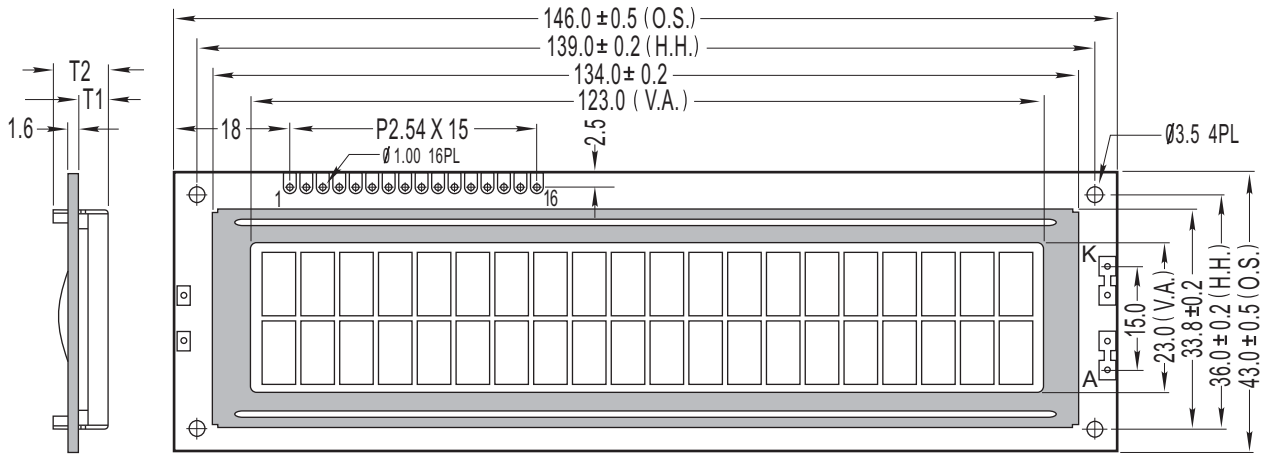

\* O.S.=Overall Size  
 \* V.A.=Viewing Area  
 \* H.H.=Hole -Hole

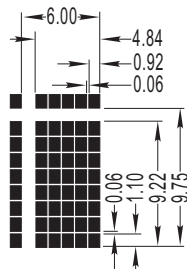

ITEM	T1	T2	UNIT
LED backlight	9.4	14.2	mm
EL or without backlight	4.6	10.0	mm

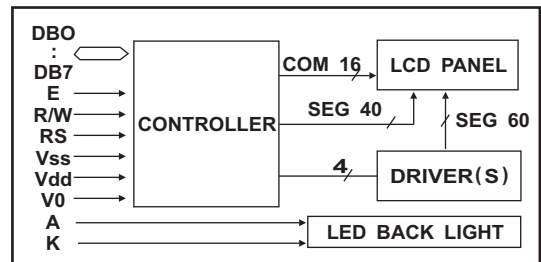

**FEATURE**

1. 5X8 dots with cursor
2. Built-in controller (SPLC780D or Equivalent)
3. +5V power supply (Also available for +3.0V)
4. 1/16 duty cycle
5. BKL to be driven by pin1, pin2, or pin15, pin16 or A, K
6. N.V. Optional

**ABSOLUTE MAXIMUM RATINGS**

ITEM	SYMBOL	MIN	MAX	UNIT
POWER SUPPLY (LOGIC)	Vdd	-0.3	7.0	V
POWER SUPPLY (LCD)	V0	Vdd-13.5	Vdd+0.3	V
INPUT VOLTAGE	Vin	-0.3	Vdd+0.3	V

**PIN ASSIGNMENT**

PIN	SYMBOL	FUNCTION
1	Vss	GND
2	Vdd	Power Supply
3	V0	Contrast Adjust
4	RS	Register Select Signal
5	R/W	Data Read/Write
6	E	Enable Signal
7-14	DB0-DB7	Data Bus Line
15(A)	LED+	Power supply for BKL(+)
16(K)	LED-	Power supply for BKL(-)

**MECHANICAL SPECIFICATIONS**

CHARACTER NUMBER	20W X 2H	—
OVERALL SIZE	146.00W X 43.00H	mm
VIEWING AREA	123.00W X 23.00H	mm
HOLE - HOLE	139.00W X 36.00H	mm
CHARACTER SIZE	4.84W X 9.22H	mm
CHARACTER PITCH	1.16W X 0.53H	mm
DOT SIZE	0.92W X 1.10H	mm
DOT PITCH	0.06W X 0.06H	mm

**ELECTRONICAL CHARACTERISTICS**

ITEM	SYMBOL	CONDITION	STANDARD			UNIT
			MIN	TYP	MAX	
Input voltage	Vdd	+5V	4.7	5.0	5.5	V
		+3.3V	2.7	3.0	3.3	V
Supply current	Idd	Vdd=5V	---	2.5	4.0	mA
Recommended LCD driving voltage for normal temp version module	Vdd-V0	0 °C	4.7	4.8	5.5	V
		25 °C	4.3	4.5	4.7	
		50 °C	4.1	4.4	4.5	
LED forward voltage	V <sub>F</sub>	25 °C	---	4.2	4.6	V
LED forward current	I <sub>F</sub>	25 °C	---	300	---	mA
EL power supply current	EL	AC 400Hz V <sub>EL</sub> =110V	---	---	---	mA

**DISPLAY CHARACTER ADDRESS CODE**

Display position	1 2 3 4 5 -- -- -- -- --	18 19 20
DDRAM address	00 01 02 -- -- -- -- --	11 12 13
DDRAM address	40 41 42 -- -- -- -- --	51 52 53

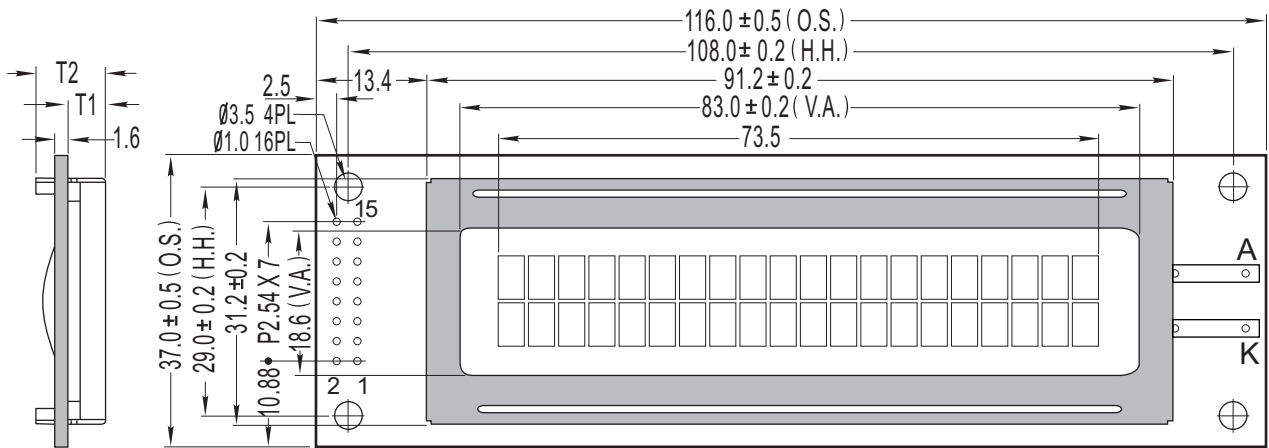

\* O.S.=Overall Size  
 \* V.A.=Viewing Area  
 \* H.H.=Hole-Hole

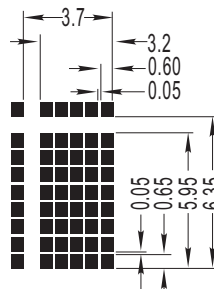

ITEM	T1	T2	UNIT
LED backlight	9.3	13.5	mm
EL or without backlight	4.6	9.5	mm

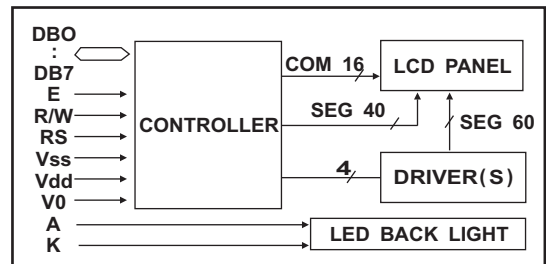

**FEATURE**

1. 5X8 dots with cursor
2. Built-in controller (SPLC780D or Equivalent)
3. +5V power supply (Also available for +3.0V)
4. 1/16 duty cycle
5. BKL to be driven by pin1, pin2, or pin15, pin16 or A, K
6. N.V. Optional

**ABSOLUTE MAXIMUM RATINGS**

ITEM	SYMBOL	MIN	MAX	UNIT
POWER SUPPLY (LOGIC)	Vdd	-0.3	7.0	V
POWER SUPPLY (LCD)	V0	Vdd-13.5	Vdd+0.3	V
INPUT VOLTAGE	Vin	-0.3	Vdd+0.3	V

**PIN ASSIGNMENT**

PIN	SYMBOL	FUNCTION
1	Vss	GND
2	Vdd	Power Supply
3	V0	Contrast Adjust
4	RS	Register Select Signal
5	R/W	Data Read/Write
6	E	Enable Signal
7-14	DB0-DB7	Data Bus Line
15(A)	LED+	Power supply for BKL(+)
16(K)	LED-	Power supply for BKL(-)

**MECHANICAL SPECIFICATIONS**

CHARACTER NUMBER	20W X 2H	—
OVERALL SIZE	116.00W X 37.00H	mm
VIEWING AREA	83.00W X 18.60H	mm
HOLE - HOLE	108.00W X 29.00H	mm
CHARACTER SIZE	3.20W X 5.95H	mm
CHARACTER PITCH	0.50W X 0.40H	mm
DOT SIZE	0.60W X 0.65H	mm
DOT PITCH	0.05W X 0.05H	mm

**ELECTRONICAL CHARACTERISTICS**

ITEM	SYMBOL	CONDITION	STANDARD			UNIT
			MIN	TYP	MAX	
Input voltage	Vdd	+5V	4.7	5.0	5.5	V
		+3.3V	2.7	3.0	3.3	V
Supply current	Idd	Vdd=5V	---	2.5	4.0	mA
Recommended LCD driving voltage for normal temp version module	Vdd-V0	0 °C	4.7	5.0	5.5	V
		25 °C	4.3	4.5	4.7	
		50 °C	4.1	4.3	4.5	
LED forward voltage	V <sub>F</sub>	25 °C	---	4.2	4.6	V
LED forward current	I <sub>F</sub>	25 °C	---	140	---	mA
EL power supply current	EL	AC 400Hz V <sub>EL</sub> =110V	----	---	---	mA

**DISPLAY CHARACTER ADDRESS CODE**

Display position	1 2 3 4 5 -- -- -- -- --	18 19 20
DDRAM address	00 01 02 -- -- -- -- --	11 12 13
DDRAM address	40 41 42 -- -- -- -- --	51 52 53

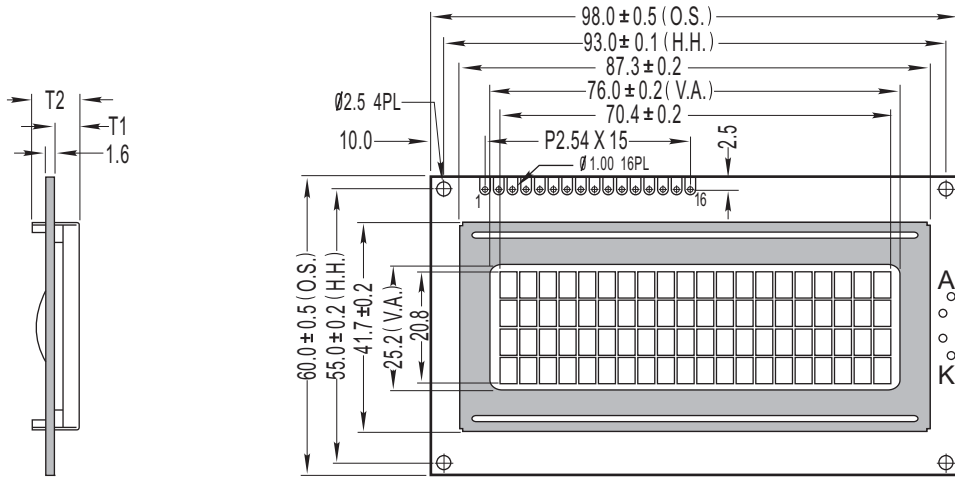

\* O.S.=Overall Size  
 \* V.A.=Viewing Area  
 \* H.H.=Hole -Hole

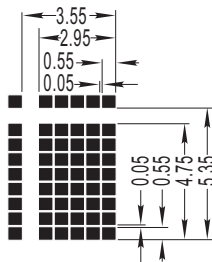

ITEM	T1	T2	UNIT
LED backlight	9.3	14.0	mm
EL or without backlight	4.6	9.5	mm

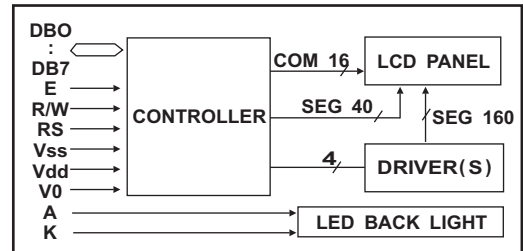

**FEATURE**

1. 5X8 dots with cursor
2. Built-in controller (SPLC780D or Equivalent)
3. +5V power supply (Also available for +3.0V)
4. 1/16 duty cycle
5. BKL to be driven by pin1, pin2, or pin15, pin16 or A, K
6. N.V. Optional

**MECHANICAL SPECIFICATIONS**

CHARACTER NUMBER	20W X 4H	—
OVERALL SIZE	98.00W X 60.00H	mm
VIEWING AREA	76.00W X 25.20H	mm
HOLE - HOLE	93.00W X 55.00H	mm
CHARACTER SIZE	2.95W X 4.75H	mm
CHARACTER PITCH	0.60W X 0.60H	mm
DOT SIZE	0.55W X 0.55H	mm
DOT PITCH	0.05W X 0.05H	mm

**ABSOLUTE MAXIMUM RATINGS**

ITEM	SYMBOL	MIN	MAX	UNIT
POWER SUPPLY (LOGIC)	Vdd	-0.3	7.0	V
POWER SUPPLY (LCD)	V0	Vdd-13.5	Vdd+0.3	V
INPUT VOLTAGE	Vin	-0.3	Vdd+0.3	V

**PIN ASSIGNMENT**

PIN	SYMBOL	FUNCTION
1	Vss	GND
2	Vdd	Power Supply
3	V0	Contrast Adjust
4	RS	Register Select Signal
5	R/W	Data Read/Write
6	E	Enable Signal
7-14	DB0-DB7	Data Bus Line
15(A)	LED+	Power supply for BKL(+)
16(K)	LED-	Power supply for BKL(-)

**ELECTRONICAL CHARACTERISTICS**

ITEM	SYMBOL	CONDITION	STANDARD			UNIT
			MIN	TYP	MAX	
Input voltage	Vdd	+5V	4.7	5.0	5.5	V
		+3.3V	2.7	3.0	3.3	V
Supply current	Idd	Vdd=5V	---	3.0	5.0	mA
Recommended LCD driving voltage for normal temp version module	Vdd-V0	0 °C	4.7	5.0	5.5	V
		25 °C	4.3	4.5	4.7	
		50 °C	4.1	4.3	4.5	
LED forward voltage	V <sub>F</sub>	25 °C	---	4.2	4.6	V
LED forward current	I <sub>F</sub>	25 °C	---	240	---	mA

**DISPLAY CHARACTER ADDRESS CODE**

Display position	1	2	3	4	--	--	--	--	19	20
DDRAM address	00	01	02	--	--	--	--	--	12	13
DDRAM address	40	41	42	--	--	--	--	--	52	53
DDRAM address	14	15	16	--	--	--	--	--	26	27
DDRAM address	54	55	56	--	--	--	--	--	66	67



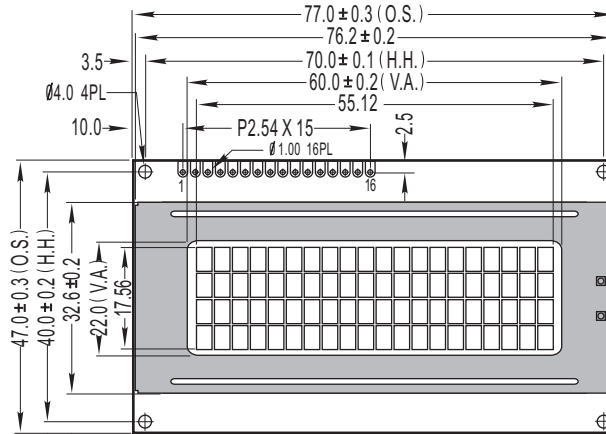
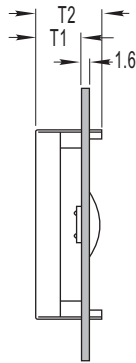

\* O.S.=Overall Size  
 \* V.A.=Viewing Area  
 \* H.H.=Hole -Hole

ITEM	T1	T2	UNIT
LED backlight	9.6	14.5	mm
EL or without backlight	5.0	9.5	mm

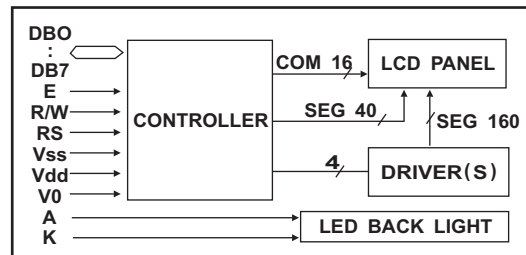
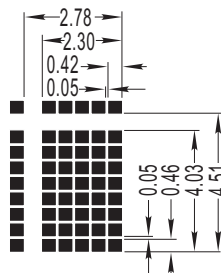

**FEATURE**

1. 5X8 dots with cursor
2. Built-in controller (SPLC780D or Equivalent)
3. +5V power supply (Also available for +3.0V)
4. 1/16 duty cycle
5. BKL to be driven by pin1, pin2, or pin15, pin16 or A, K
6. N.V. Optional

**MECHANICAL SPECIFICATIONS**

CHARACTER NUMBER	20W X 4H	—
OVERALL SIZE	77.00W X 47.00H	mm
VIEWING AREA	60.00W X 22.00H	mm
HOLE - HOLE	70.00W X 40.00H	mm
CHARACTER SIZE	2.30W X 4.03H	mm
CHARACTER PITCH	0.48W X 0.48H	mm
DOT SIZE	0.42W X 0.46H	mm
DOT PITCH	0.05W X 0.05H	mm

**ABSOLUTE MAXIMUM RATINGS**

ITEM	SYMBOL	MIN	MAX	UNIT
POWER SUPPLY (LOGIC)	Vdd	-0.3	7.0	V
POWER SUPPLY (LCD)	V0	Vdd-13.5	Vdd+0.3	V
INPUT VOLTAGE	Vin	-0.3	Vdd+0.3	V

**ELECTRONICAL CHARACTERISTICS**

ITEM	SYMBOL	CONDITION	STANDARD			UNIT
			MIN	TYP	MAX	
Input voltage	Vdd	+5V	4.7	5.0	5.5	V
		+3.3V	2.7	3.0	3.3	V
Supply current	Idd	Vdd=5V	---	1.5	3.5	mA
Recommended LCD driving voltage for normal temp version module	Vdd-V0	0 °C	4.7	5.0	5.5	V
		25 °C	4.3	4.5	4.7	
		50 °C	4.1	4.3	4.5	
LED forward voltage	V <sub>F</sub>	25 °C	---	4.2	4.6	V
LED forward current	I <sub>F</sub>	25 °C	---	150	---	mA

**PIN ASSIGNMENT**

PIN	SYMBOL	FUNCTION
1	Vss	GND
2	Vdd	Power Supply
3	V0	Contrast Adjust
4	RS	Register Select Signal
5	R/W	Data Read/Write
6	E	Enable Signal
7-14	DB0-DB7	Data Bus Line
15(A)	LED+	Power supply for BKL(+)
16(K)	LED-	Power supply for BKL(-)

**DISPLAY CHARACTER ADDRESS CODE**

Display position	1 2 3 4 -- -- -- --	19 20
DDRAM address	00 01 02 -- -- -- --	12 13
DDRAM address	40 41 42 -- -- -- --	52 53
DDRAM address	14 15 16 -- -- -- --	26 27
DDRAM address	54 55 56 -- -- -- --	66 67

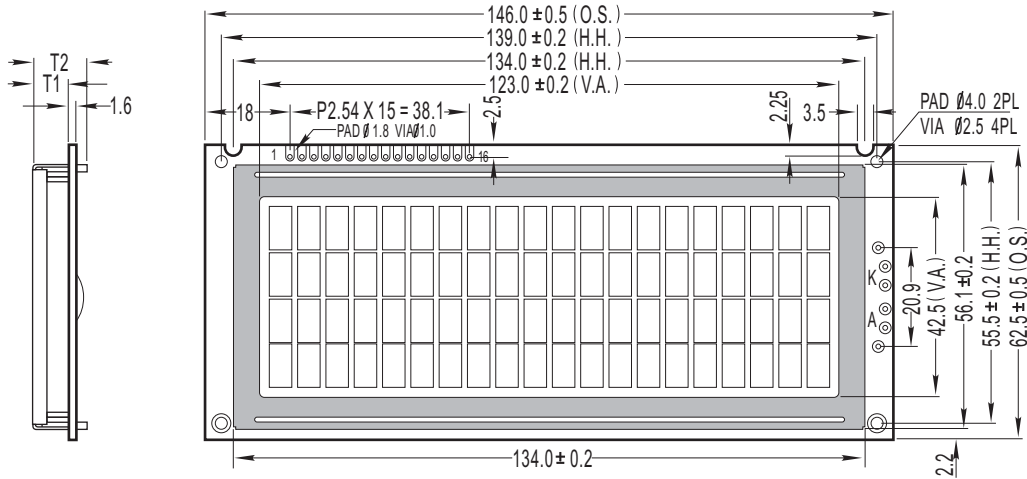

\* O.S.=Overall Size  
 \* V.A.=Viewing Area  
 \* H.H.=Hole-Hole

ITEM	T1	T2	UNIT
LED backlight	9.4	14.5	mm
EL or without backlight	5.6	10.5	mm

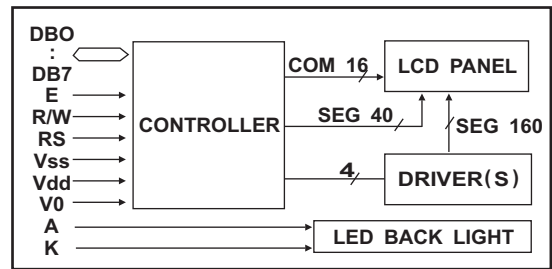
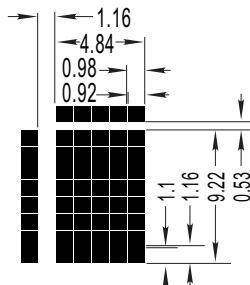

**FEATURE**

1. 5X8 dots with cursor
2. Built-in controller (SPLC780D or Equivalent)
3. +5V power supply (Also available for +3.0V)
4. 1/16 duty cycle
5. BKL to be driven by pin1, pin2, or pin15, pin16
6. N.V. Optional

**ABSOLUTE MAXIMUM RATINGS**

ITEM	SYMBOL	MIN	MAX	UNIT
POWER SUPPLY (LOGIC)	Vdd	-0.3	7.0	V
POWER SUPPLY (LCD)	V0	Vdd-13.5	Vdd+0.3	V
INPUT VOLTAGE	Vin	-0.3	Vdd+0.3	V

**PIN ASSIGNMENT**

PIN	SYMBOL	FUNCTION
1	Vss	GND
2	Vdd	Power Supply
3	V0	Contrast Adjust
4	RS	Register Select Signal
5	R/W	Data Read/Write
6	E	Enable Signal
7-14	DB0-DB7	Data Bus Line
15(A)	LED+	Power supply for BKL(+)
16(K)	LED-	Power supply for BKL(-)

**MECHANICAL SPECIFICATIONS**

CHARACTER NUMBER	20W X 4H	—
OVERALL SIZE	146.00W X 62.50H	mm
VIEWING AREA	123.00W X 42.50H	mm
HOLE - HOLE	139.0/134.0W X 55.5H	mm
CHARACTER SIZE	4.84W X 9.22H	mm
CHARACTER PITCH	1.16W X 0.53H	mm
DOT SIZE	0.92W X 1.10H	mm
DOT PITCH	0.06W X 0.06H	mm

**ELECTRONICAL CHARACTERISTICS**

ITEM	SYMBOL	CONDITION	STANDARD			UNIT
			MIN	TYP	MAX	
Input voltage	Vdd	+5V	4.7	5.0	5.5	V
		+3.3V	2.7	3.0	3.3	V
Supply current	Idd	Vdd=5V	---	1.7	2.0	mA
Recommended LCD driving voltage for normal temp version module	Vdd-V0	0 °C	4.7	5.0	5.5	V
		25 °C	4.3	4.5	4.7	
		50 °C	4.1	4.3	4.5	
LED forward voltage	V <sub>F</sub>	25 °C	---	4.2	4.6	V
LED forward current	I <sub>F</sub>	25 °C	---	240	---	mA

**DISPLAY CHARACTER ADDRESS CODE**

Display position	1	2	3	4	--	--	--	--	19	20
DDRAM address	00	01	02	--	--	--	--	--	12	13
DDRAM address	40	41	42	--	--	--	--	--	52	53
DDRAM address	14	15	16	--	--	--	--	--	26	27
DDRAM address	54	55	56	--	--	--	--	--	66	67

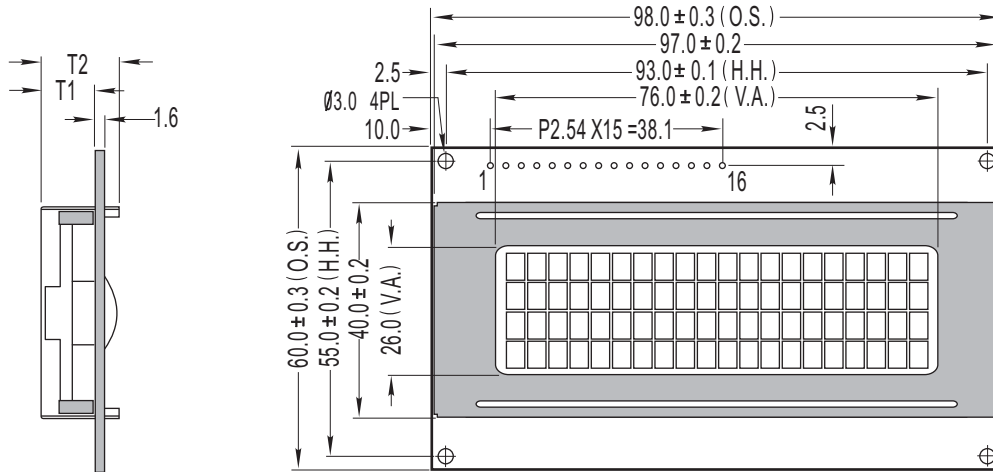

\* O.S.=Overall Size  
 \* V.A.=Viewing Area  
 \* H.H.=Hole-Hole

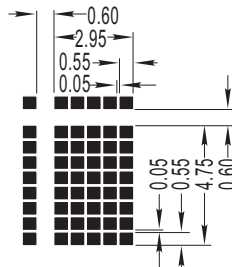

ITEM	T1	T2	UNIT
LED backlight	9.8	14.5	mm
EL or without backlight	4.6	9.5	mm

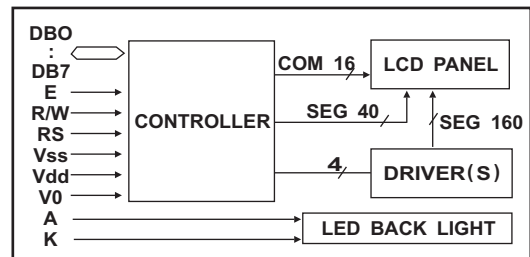

**FEATURE**

1. 5X8 dots with cursor
2. Built-in controller (SPLC780D or Equivalent)
3. +5V power supply (Also available for +3.0V)
4. 1/16 duty cycle
5. BKL to be driven by pin1, pin2, or pin15, pin16
6. N.V. Optional

**MECHANICAL SPECIFICATIONS**

CHARACTER NUMBER	20W X 4H	—
OVERALL SIZE	98.00W X 60.00H	mm
VIEWING AREA	76.00W X 26.00H	mm
HOLE - HOLE	93.00W X 55.00H	mm
CHARACTER SIZE	2.95W X 4.75H	mm
CHARACTER PITCH	0.60W X 0.60H	mm
DOT SIZE	0.55W X 0.55H	mm
DOT PITCH	0.05W X 0.05H	mm

**ABSOLUTE MAXIMUM RATINGS**

ITEM	SYMBOL	MIN	MAX	UNIT
POWER SUPPLY (LOGIC)	Vdd	-0.3	7.0	V
POWER SUPPLY (LCD)	V0	Vdd-13.5	Vdd+0.3	V
INPUT VOLTAGE	Vin	-0.3	Vdd+0.3	V

**ELECTRONICAL CHARACTERISTICS**

ITEM	SYMBOL	CONDITION	STANDARD			UNIT
			MIN	TYP	MAX	
Input voltage	Vdd	+5V	4.7	5.0	5.5	V
		+3.3V	2.7	3.0	3.3	V
Supply current	Idd	Vdd=5V	---	1.5	3.5	mA
Recommended LCD driving voltage for normal temp version module	Vdd-V0	0 °C	4.7	5.0	5.5	V
		25 °C	4.3	4.5	4.7	
		50 °C	4.1	4.3	4.5	
LED forward voltage	V <sub>F</sub>	25 °C	---	4.2	4.6	V
LED forward current	I <sub>F</sub>	25 °C	---	150	---	mA

**PIN ASSIGNMENT**

PIN	SYMBOL	FUNCTION
1	Vss	GND
2	Vdd	Power Supply
3	V0	Contrast Adjust
4	RS	Register Select Signal
5	R/W	Data Read/Write
6	E	Enable Signal
7-14	DB0-DB7	Data Bus Line
15	LED+	Power supply for BKL(+)
16	LED-	Power supply for BKL(-)

**DISPLAY CHARACTER ADDRESS CODE**

Display position	1 2 3 4 -- -- -- --	19 20
DDRAM address	00 01 02 -- -- -- --	12 13
DDRAM address	40 41 42 -- -- -- --	52 53
DDRAM address	14 15 16 -- -- -- --	26 27
DDRAM address	54 55 56 -- -- -- --	66 67

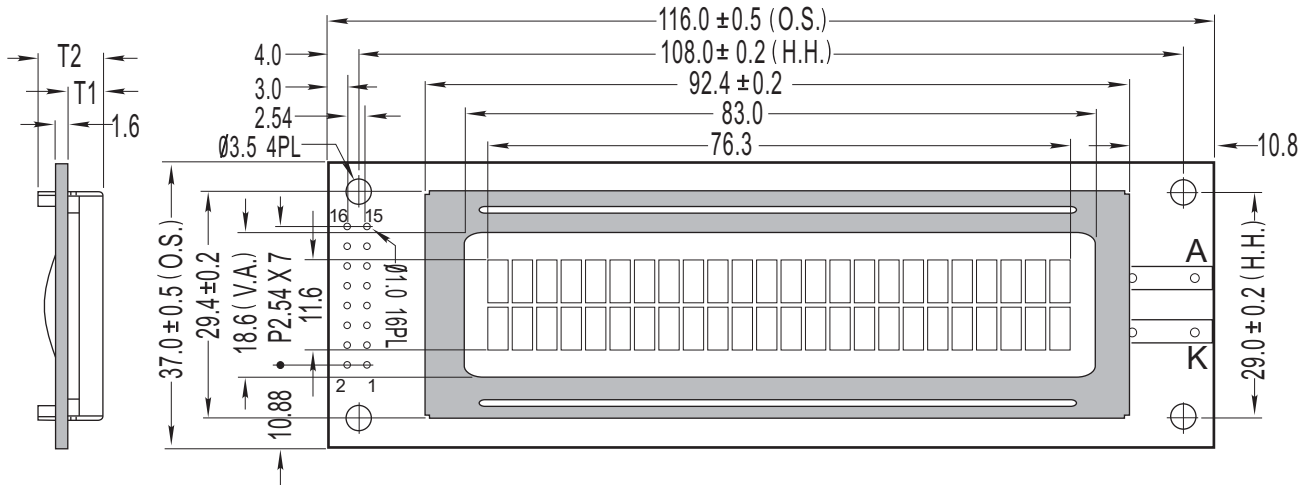

\* O.S.=Overall Size  
 \* V.A.=Viewing Area  
 \* H.H.=Hole-Hole

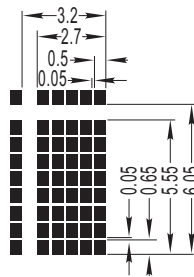

ITEM	T1	T2	UNIT
LED backlight	9.3	13.5	mm
EL or without backlight	4.6	9.5	mm

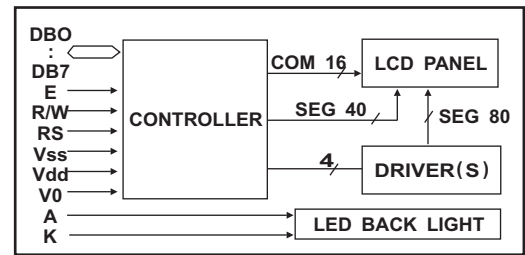

**FEATURE**

1. 5X8 dots with cursor
2. Built-in controller (SPLC780D or Equivalent)
3. +5V power supply (Also available for +3.0V)
4. 1/16 duty cycle
5. BKL to be driven by pin1, pin2, or pin15, pin16 or A, K
6. N.V. Optional

**MECHANICAL SPECIFICATIONS**

CHARACTER NUMBER	24W X 2H	—
OVERALL SIZE	116.00W X 37.00H	mm
VIEWING AREA	83.00W X 18.60H	mm
HOLE - HOLE	108.00W X 29.00H	mm
CHARACTER SIZE	2.70W X 5.55H	mm
CHARACTER PITCH	0.50W X 0.50H	mm
DOT SIZE	0.50W X 0.65H	mm
DOT PITCH	0.05W X 0.05H	mm

**ABSOLUTE MAXIMUM RATINGS**

ITEM	SYMBOL	MIN	MAX	UNIT
POWER SUPPLY (LOGIC)	Vdd	-0.3	7.0	V
POWER SUPPLY (LCD)	V0	Vdd-13.5	Vdd+0.3	V
INPUT VOLTAGE	Vin	-0.3	Vdd+0.3	V

**ELECTRONICAL CHARACTERISTICS**

ITEM	SYMBOL	CONDITION	STANDARD			UNIT
			MIN	TYP	MAX	
Input voltage	Vdd	+5V	4.7	5.0	5.5	V
		+3.3V	2.7	3.0	3.3	V
Supply current	Idd	Vdd=5V	---	3.0	5.0	mA
Recommended LCD driving voltage for normal temp version module	Vdd-V0	0 °C	4.7	5.0	5.5	V
		25 °C	4.3	4.5	4.7	
		50 °C	4.1	4.3	4.5	
LED forward voltage	V <sub>F</sub>	25 °C	---	4.2	4.6	V
LED forward current	I <sub>F</sub>	25 °C	---	300	---	mA
EL power supply current	EL	AC 400Hz V <sub>EL</sub> =110V	----	---	---	mA

**PIN ASSIGNMENT**

PIN	SYMBOL	FUNCTION
1	Vss	GND
2	Vdd	Power Supply
3	V0	Contrast Adjust
4	RS	Register Select Signal
5	R/W	Data Read/Write
6	E	Enable Signal
7-14	DB0-DB7	Data Bus Line
15(A)	LED+	Power supply for BKL(+)
16(K)	LED-	Power supply for BKL(-)

**DISPLAY CHARACTER ADDRESS CODE**

Display position	1 2 3 -- -- -- --	23 24
DDRAM address	00 01 02 -- -- -- --	16 17
DDRAM address	40 41 42 -- -- -- --	56 57

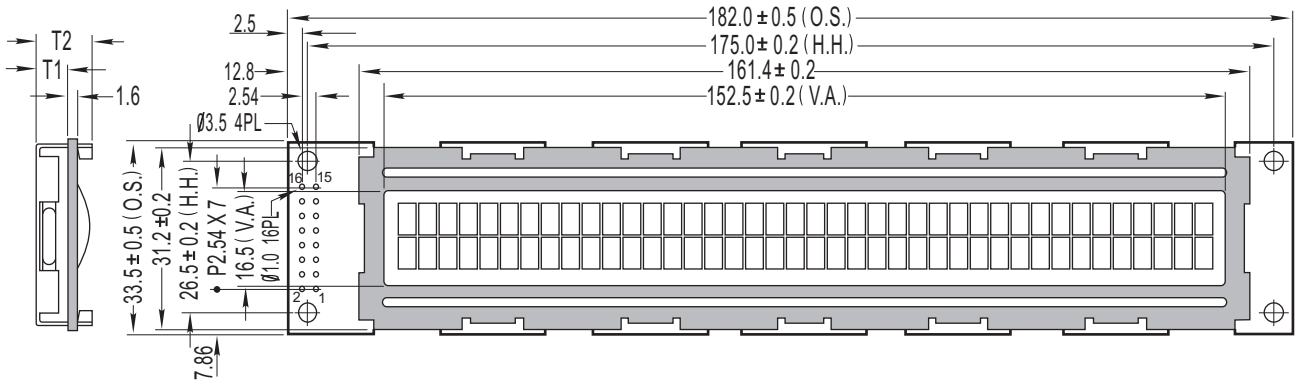

\* O.S.=Overall Size  
 \* V.A.=Viewing Area  
 \* H.H.=Hole -Hole

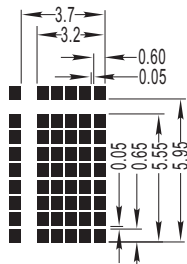

ITEM	T1	T2	UNIT
LED backlight	9.3	14.0	mm
EL or without backlight	5.4	11.0	mm

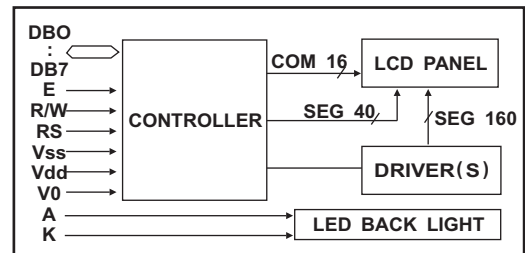

**FEATURE**

1. 5X8 dots with cursor
2. Built-in controller (SPLC780D or Equivalent)
3. +5V power supply (Also available for +3.0V)
4. 1/16 duty cycle
5. BKL to be driven by pin1, pin2, or pin15, pin16
6. N.V. Optional

**ABSOLUTE MAXIMUM RATINGS**

ITEM	SYMBOL	MIN	MAX	UNIT
POWER SUPPLY (LOGIC)	Vdd	-0.3	7.0	V
POWER SUPPLY (LCD)	V0	Vdd-13.5	Vdd+0.3	V
INPUT VOLTAGE	Vin	-0.3	Vdd+0.3	V

**PIN ASSIGNMENT**

PIN	SYMBOL	FUNCTION
1	Vss	GND
2	Vdd	Power Supply
3	V0	Contrast Adjust
4	RS	Register Select Signal
5	R/W	Data Read/Write
6	E	Enable Signal
7-14	DB0-DB7	Data Bus Line
15	LED+	Power supply for BKL(+)
16	LED-	Power supply for BKL(-)

**MECHANICAL SPECIFICATIONS**

CHARACTER NUMBER	40W X 2H	—
OVERALL SIZE	182.00W X 33.50H	mm
VIEWING AREA	152.50W X 16.50H	mm
HOLE - HOLE	175.00W X 26.50H	mm
CHARACTER SIZE	3.20W X 5.55H	mm
CHARACTER PITCH	0.50W X 0.40H	mm
DOT SIZE	0.60W X 0.65H	mm
DOT PITCH	0.05W X 0.05H	mm

**ELECTRONICAL CHARACTERISTICS**

ITEM	SYMBOL	CONDITION	STANDARD			UNIT
			MIN	TYP	MAX	
Input voltage	Vdd	+5V	4.7	5.0	5.5	V
		+3.3V	2.7	3.0	3.3	V
Supply current	Idd	Vdd=5V	---	3.0	5.0	mA
Recommended LCD driving voltage for normal temp version module	Vdd-V0	0 °C	4.7	5.0	5.5	V
		25 °C	4.3	4.5	4.7	
		50 °C	4.1	4.3	4.5	
LED forward voltage	V <sub>F</sub>	25 °C	---	4.2	4.6	V
LED forward current	I <sub>F</sub>	25 °C	---	300	---	mA
EL power supply current	EL	AC 400Hz V <sub>EL</sub> =110V	----	---	---	mA

**DISPLAY CHARACTER ADDRESS CODE**

Display position	1 2 3 4 5 6 -- -- -- -- --	40
DDRAM address	00 01 02 -- -- -- -- --	27
DDRAM address	40 41 42 -- -- -- -- --	67



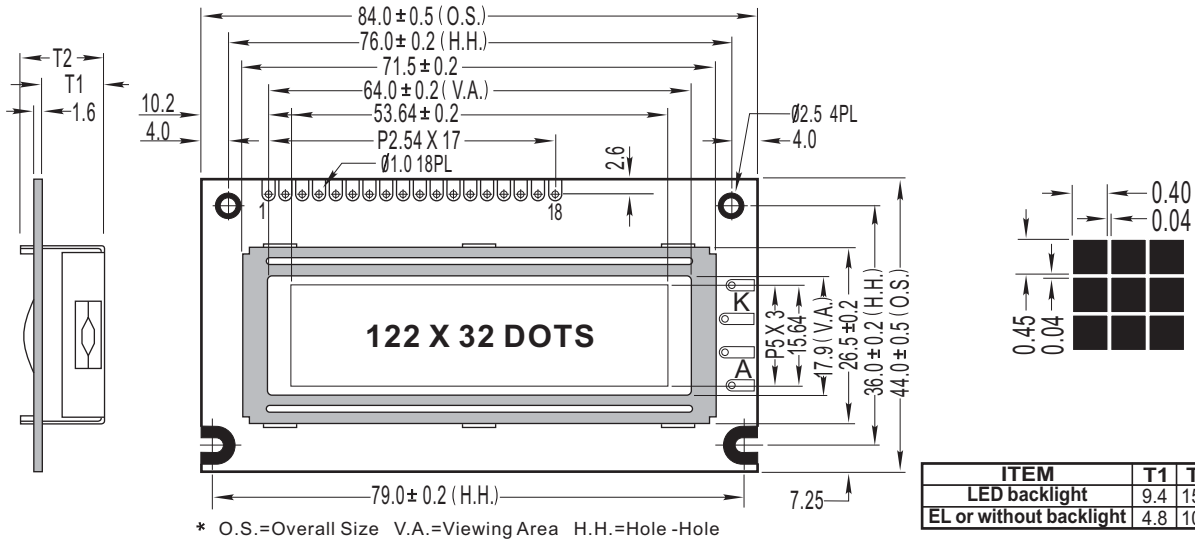

ITEM	T1	T2	UNIT
LED backlight	9.4	15.0	mm
EL or without backlight	4.8	10.0	mm

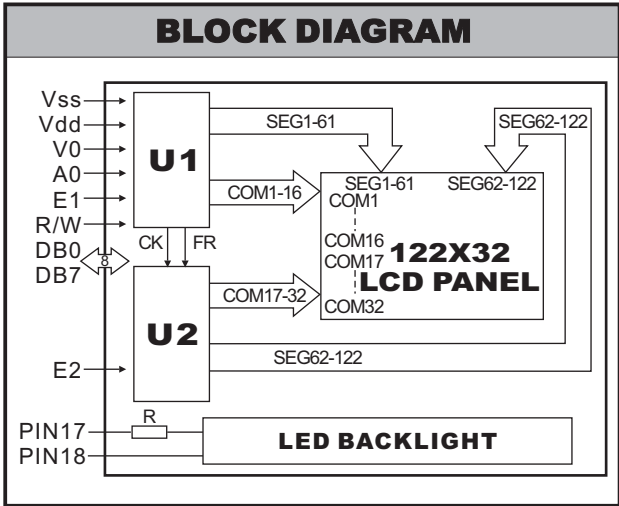

- ### FEATURE
- 122X32 dots graphic LCD module
  - Built-in controller (SED1520D0A)
  - +5V power supply
  - STN LCD panel, 1/32 duty cycle

### MECHANICAL SPECIFICATIONS

PARAMETER	VALUE	UNIT
DOT NUMBER	122W X 32H	—
OVERALL SIZE	84.00W X 44.00H	mm
VIEWING AREA	64.00W X 17.90H	mm
HOLE - HOLE	79.50/76.00W X 36.00H	mm
DOT SIZE	0.40W X 0.45H	mm
DOT PITCH	0.04W X 0.04H	mm

### PIN ASSIGNMENT

PIN	SYMBOL	FUNCTION
1	Vss	GND
2	Vdd	Power Supply
3	V0	Contrast Adjust
4	RST	H/L Reset signal
5	E1	Chip enable signal
6	E2	Chip enable signal
7	R/W	H/L Read/write
8	A0	H/L H:Data L:Instruction code
9 to 16	DB0 to DB7	H/L Data bus line
17(A)	LED+	Power supply for BKL(+)
18(K)	LED-	Power supply for BKL(-)

### ABSOLUTE MAXIMUM RATINGS

ITEM	SYMBOL	MIN	MAX	UNIT
POWER SUPPLY (LOGIC)	Vdd	-0.3	7.0	V
POWER SUPPLY (LCD)	V0	Vdd -13.5	Vdd +0.3	V
INPUT VOLTAGE	Vin	-0.3	Vdd +0.3	V

### ELECTRONICAL CHARACTERISTICS

ITEM	SYMBOL	CONDITION	STANDARD			UNIT
			MIN	TYP	MAX	
Input voltage	Vdd	+5V	4.7	5.0	5.5	V
Supply current	Idd	Vdd=5V	---	2.5	---	mA
Recommended LCD driving voltage for normal temp version module	Vdd-V0	0 °C	4.7	5.0	5.5	V
		25 °C	4.3	4.5	4.7	
		50 °C	4.1	4.3	4.5	
LED forward voltage	V <sub>F</sub>	25 °C	---	4.2	4.5	V
LED forward current	I <sub>F</sub>	25 °C	---	120	---	mA

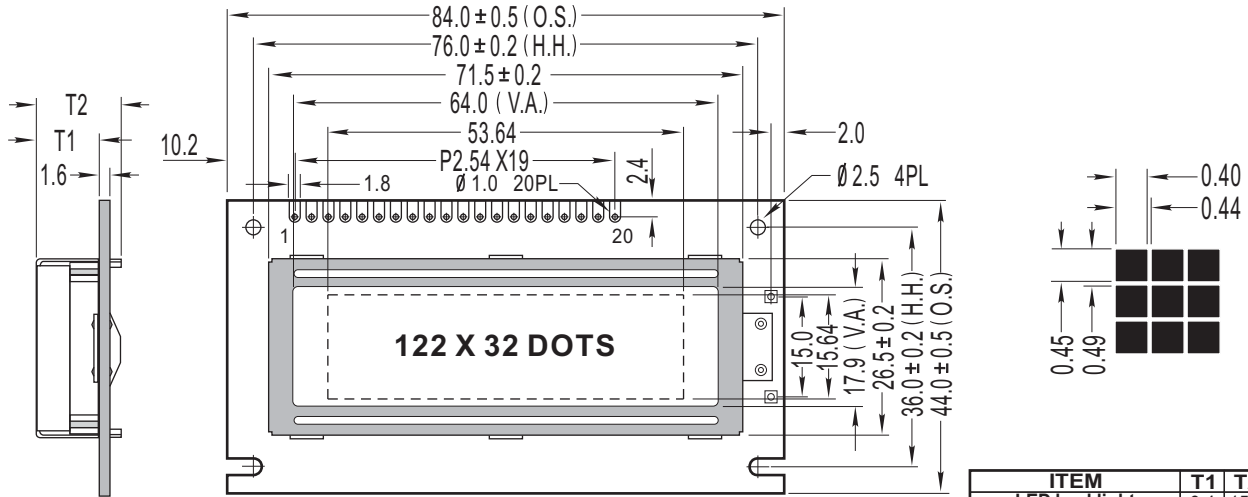

\* O.S.=Overall Size V.A.=Viewing Area H.H.=Hole -Hole

ITEM	T1	T2	UNIT
LED backlight	9.4	15.0	mm
EL or without backlight	4.8	10.0	mm

**BLOCK DIAGRAM**

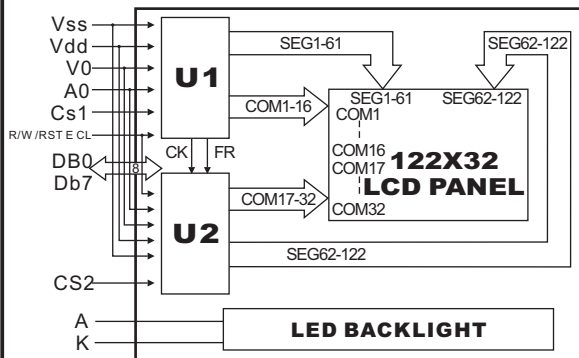

**FEATURE**

1. 122X32 dots graphic LCD module
2. Built-in controller (SED1520DAA)
3. +5V power supply
4. STN LCD panel, 1/32 duty cycle

**MECHANICAL SPECIFICATIONS**

DOT NUMBER	122W X 32H	—
OVERALL SIZE	84.00W X 44.00H	mm
VIEWING AREA	64.00W X 17.90H	mm
HOLE - HOLE	76.00W X 36.00H	mm
DOT SIZE	0.40W X 0.45H	mm
DOT PITCH	0.04W X 0.04H	mm

**PIN ASSIGNMENT**

PIN	SYMBOL	FUNCTION
1	Vss	GND
2	Vdd	Power Supply
3	V0	Contrast Adjust
4	A0	H/L H:Data L:Instruction code
5	CS1	Chip enable signal
6	CS2	Chip enable signal
7	CL	Clock input (2KHz)
8	E	Enable Signal
9	R/W	H/L Read/write
10 to 17	DB0 to DB7	H/L Data bus line
18	RST	H/L Reset signal
19(A)	LED+	Power supply for BKL(+)
20(K)	LED-	Power supply for BKL(-)

**ABSOLUTE MAXIMUM RATINGS**

ITEM	SYMBOL	MIN	MAX	UNIT
POWER SUPPLY (LOGIC)	Vdd	-0.3	7.0	V
POWER SUPPLY (LCD)	V0	Vdd-13.5	Vdd+0.3	V
INPUT VOLTAGE	Vin	-0.3	Vdd+0.3	V

**ELECTRONICAL CHARACTERISTICS**

ITEM	SYMBOL	CONDITION	STANDARD			UNIT
			MIN	TYP	MAX	
Input voltage	Vdd	+5V	3.0	5.0	5.5	V
Supply current	Idd	Vdd=5V	---	1.0	---	mA
Recommended LCD driving voltage for normal temp version module	Vdd-V0	0 °C	---	4.8	---	V
		25 °C	---	4.6	---	
		50 °C	---	4.4	---	
LED forward voltage	V <sub>F</sub>	25 °C	---	4.2	4.5	V
LED forward current	I <sub>F</sub>	25 °C	---	120	---	mA



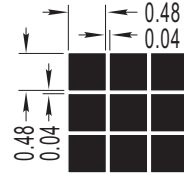
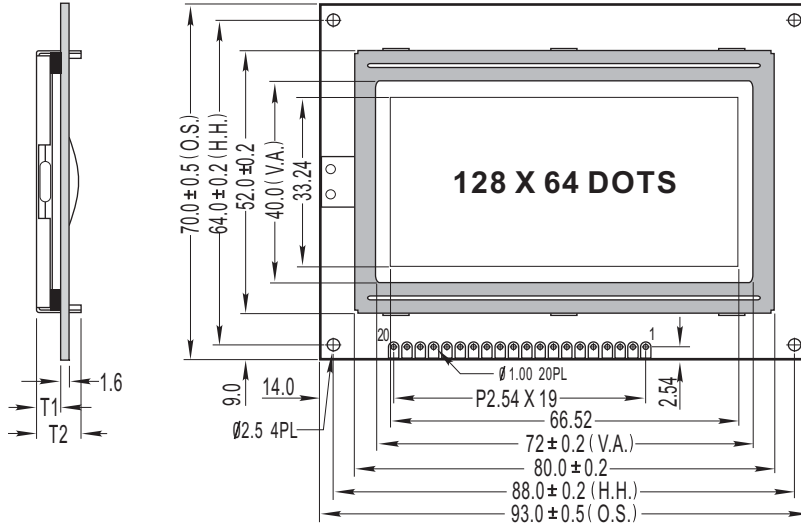

ITEM	T1	T2	UNIT
LED backlight	8.7	13.0	mm
EL or without backlight	4.6	9.0	mm

\* O.S.=Overall Size V.A.=Viewing Area H.H.=Hole -Hole

**BLOCK DIAGRAM**

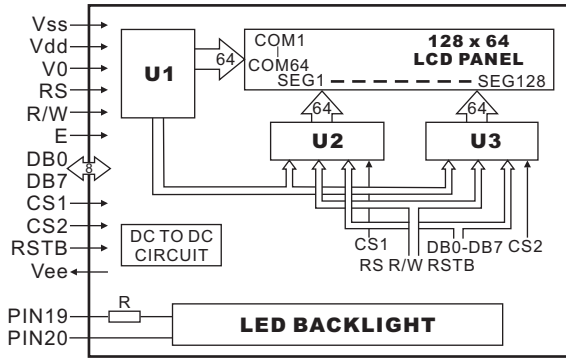

**FEATURE**

1. 128X64 dots graphic LCD module
2. Built- in controller (KS0108B)
3. +5V power supply
4. STN LCD panel, 1/64 duty cycle

**MECHANICAL SPECIFICATIONS**

PARAMETER	VALUE	UNIT
DOT NUMBER	128W X 64H	—
OVERALL SIZE	93.00W X 70.00H	mm
VIEWING AREA	72.00W X 40.00H	mm
HOLE - HOLE	88.00W X 64.00H	mm
DOT SIZE	0.48W X 0.48H	mm
DOT PITCH	0.04W X 0.04H	mm

**PIN ASSIGNMENT**

PIN	SYMBOL	FUNCTION
1	Vss	GND
2	Vdd	Power Supply
3	V0	Contrast Adjust
4	RS	H/L Register select signal
5	R/W	H/L Read/write
6	E	Chip enable signal
7 to 14	DB0 to DB7	H/L Data bus line
15	CS1	Chip select for IC1
16	CS2	Chip select for IC2
17	RST	Reset signal
18	Vee	Negative voltage output
19(A)	LED+	Power supply for BKL(4.2V)
20(K)	LED-	Power supply for BKL(GND)

**ABSOLUTE MAXIMUM RATINGS**

ITEM	SYMBOL	MIN	MAX	UNIT
POWER SUPPLY (LOGIC)	Vdd	-0.3	7.0	V
POWER SUPPLY (LCD)	V0	Vdd-19.0	Vdd+0.3	V
INPUT VOLTAGE	Vin	-0.3	Vdd+0.3	V

**ELECTRONICAL CHARACTERISTICS**

ITEM	SYMBOL	CONDITION	STANDARD			UNIT
			MIN	TYP	MAX	
Input voltage	Vdd	+5V	4.7	5.0	5.5	V
Supply current	Idd	Vdd=5V	---	8	---	mA
Recommended LCD driving voltage for normal temp version module	Vdd-V0	0 °C	---	9.8	---	V
		25 °C	---	9.5	---	
		50 °C	---	9.3	---	
LED forward voltage	V <sub>F</sub>	25 °C	---	4.2	4.5	V
LED forward current	I <sub>F</sub>	25 °C	---	360	---	mA

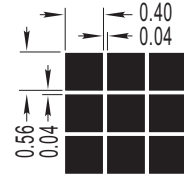
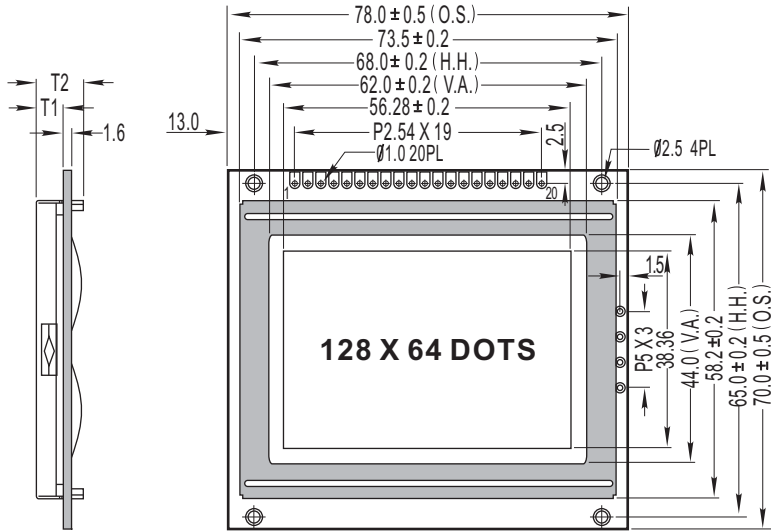

ITEM	T1	T2	UNIT
LED backlight	10.2	15.0	mm
EL or without backlight	5.0	10.0	mm

\* O.S.=Overall Size V.A.=Viewing Area H.H.=Hole -Hole

**BLOCK DIAGRAM**

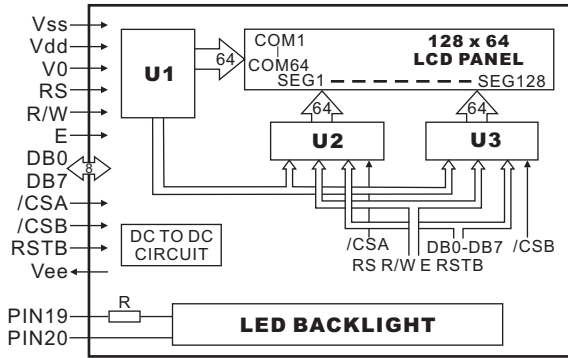

**FEATURE**

1. 128X64 dots graphic LCD module
2. Built- in controller (KS0108B)
3. +5V power supply
4. STN LCD panel, 1/64 duty cycle

**MECHANICAL SPECIFICATIONS**

PARAMETER	VALUE	UNIT
DOT NUMBER	128W X 64H	—
OVERALL SIZE	78.00W X 70.00H	mm
VIEWING AREA	62.00W X 44.00H	mm
HOLE - HOLE	68.00W X 65.00H	mm
DOT SIZE	0.40W X 0.56H	mm
DOT PITCH	0.04W X 0.04H	mm

**PIN ASSIGNMENT**

PIN	SYMBOL	FUNCTION
1	/CSA	Chip select for IC1
2	/CSB	Chip select for IC2
3	Vss	GND
4	Vdd	Power Supply
5	V0	Contrast Adjust
6	RS	H/L Register select signal
7	R/W	H/L Read/write
8	E	Chip enable signal
9 to 16	DB0 to DB7	H/L Data bus line
17	RST	Reset signal
18	Vee	Negative voltage output
19(A)	LED+	Power supply for BKL(4.2V)
20(K)	LED-	Power supply for BKL(GND)

**ABSOLUTE MAXIMUM RATINGS**

ITEM	SYMBOL	MIN	MAX	UNIT
POWER SUPPLY (LOGIC)	Vdd	-0.3	7.0	V
POWER SUPPLY (LCD)	V0	Vdd-19.0	Vdd+0.3	V
INPUT VOLTAGE	Vin	-0.3	Vdd+0.3	V

**ELECTRONICAL CHARACTERISTICS**

ITEM	SYMBOL	CONDITION	STANDARD			UNIT
			MIN	TYP	MAX	
Input voltage	Vdd	+5V	4.7	5.0	5.5	V
Supply current	Idd	Vdd=5V	---	8	---	mA
Recommended LCD driving voltage for normal temp version module	Vdd-V0	0 °C	---	9.8	---	V
		25 °C	---	9.5	---	
		50 °C	---	9.3	---	
LED forward voltage	V <sub>F</sub>	25 °C	---	4.2	4.5	V
LED forward current	I <sub>F</sub>	25 °C	---	360	---	mA

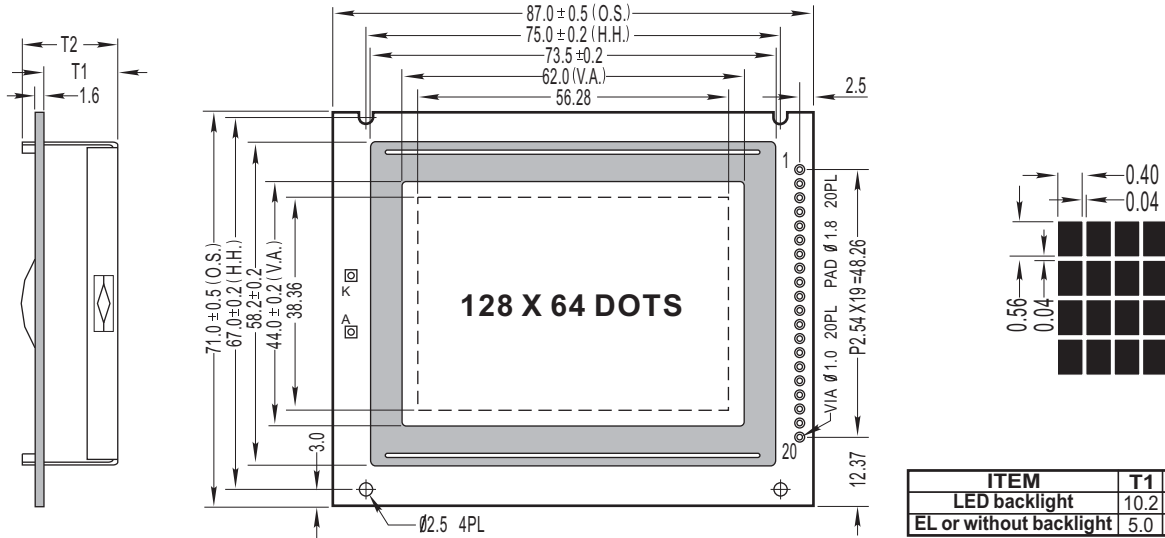

ITEM	T1	T2	UNIT
LED backlight	10.2	15.0	mm
EL or without backlight	5.0	10.0	mm

\* O.S.=Overall Size V.A.=Viewing Area H.H.=Hole -Hole

**BLOCK DIAGRAM**

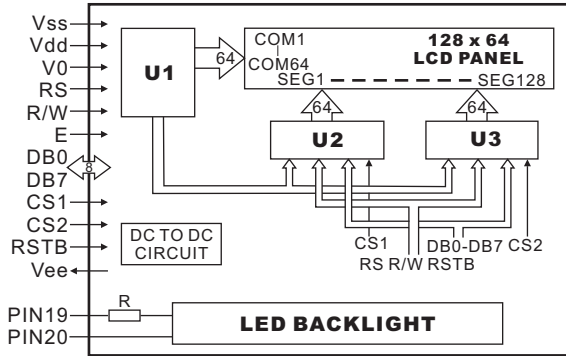

**FEATURE**

1. 128X64 dots graphic LCD module
2. Built- in controller (KS0108B)
3. +5V power supply
4. STN LCD panel, 1/64 duty cycle

**MECHANICAL SPECIFICATIONS**

PARAMETER	VALUE	UNIT
DOT NUMBER	128W X 64H	—
OVERALL SIZE	87.00W X 71.00H	mm
VIEWING AREA	62.00W X 44.00H	mm
HOLE - HOLE	75.00W X 67.00H	mm
DOT SIZE	0.40W X 0.56H	mm
DOT PITCH	0.04W X 0.04H	mm

**PIN ASSIGNMENT**

PIN	SYMBOL	FUNCTION
1	Vss	GND
2	Vdd	Power Supply
3	V0	Contrast Adjust
4	RS	H/L Register select signal
5	R/W	H/L Read/write
6	E	Chip enable signal
7 to 14	DB0 to DB7	H/L Data bus line
15	CS1	Chip select for IC1
16	RST	Reset signal
17	Vee	Negative voltage output
18	CS2	Chip select for IC2
19(A)	LED+	Power supply for BKL(4.2V)
20(K)	LED-	Power supply for BKL(GND)

**ABSOLUTE MAXIMUM RATINGS**

ITEM	SYMBOL	MIN	MAX	UNIT
POWER SUPPLY (LOGIC)	Vdd	-0.3	7.0	V
POWER SUPPLY (LCD)	V0	Vdd-19.0	Vdd+0.3	V
INPUT VOLTAGE	Vin	-0.3	Vdd+0.3	V

**ELECTRONICAL CHARACTERISTICS**

ITEM	SYMBOL	CONDITION	STANDARD			UNIT
			MIN	TYP	MAX	
Input voltage	Vdd	+5V	4.7	5.0	5.5	V
Supply current	Idd	Vdd=5V	---	8	---	mA
Recommended LCD driving voltage for normal temp version module	Vdd-V0	0 °C	---	9.8	---	V
		25 °C	---	9.5	---	
		50 °C	---	9.3	---	
LED forward voltage	V <sub>F</sub>	25 °C	---	4.2	4.6	V
LED forward current	I <sub>F</sub>	25 °C	---	240	---	mA

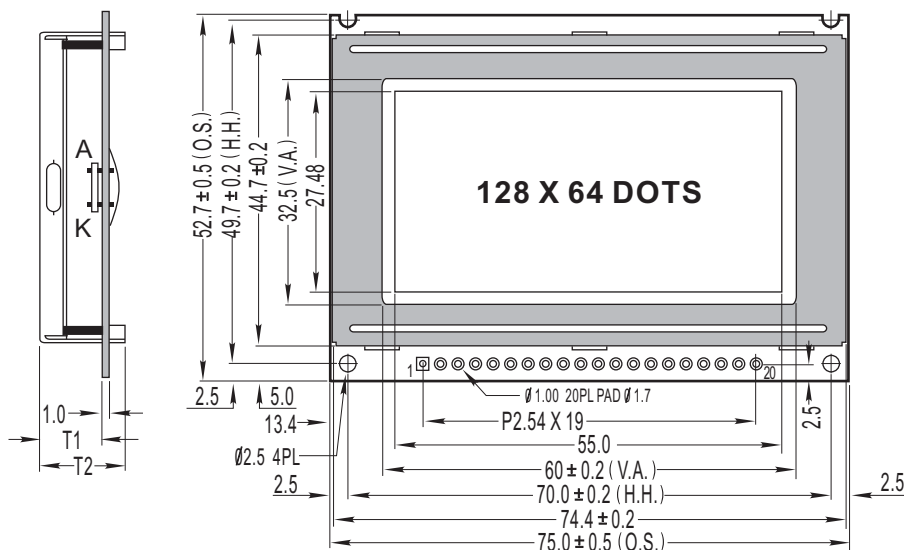

ITEM	T1	T2	UNIT
LED backlight	8.8	13.0	mm
EL or without backlight	5.4	9.0	mm

\* O.S.=Overall Size V.A.=Viewing Area H.H.=Hole -Hole

**BLOCK DIAGRAM**

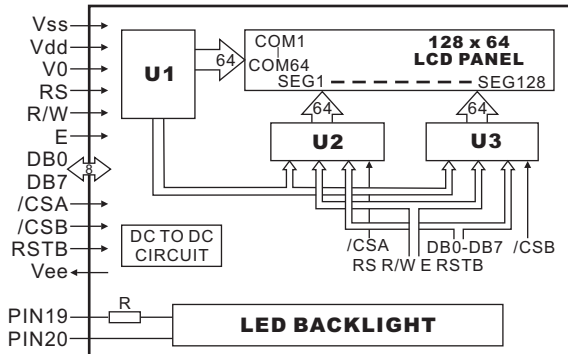

**FEATURE**

1. 128X64 dots graphic LCD module
2. Built- in controller (KS0108B)
3. +5V power supply
4. STN LCD panel, 1/64 duty cycle

**MECHANICAL SPECIFICATIONS**

PARAMETER	VALUE	UNIT
DOT NUMBER	128W X 64H	—
OVERALL SIZE	75.00W X 52.70H	mm
VIEWING AREA	60.00W X 32.50H	mm
HOLE - HOLE	70.00W X 49.70H	mm
DOT SIZE	0.39W X 0.39H	mm
DOT PITCH	0.04W X 0.04H	mm

**PIN ASSIGNMENT**

PIN	SYMBOL	FUNCTION
1	Vdd	Power Supply
2	Vss	GND
3	V0	Contrast Adjust
4 to 11	DB0 to DB7	H/L Data bus line
12	CS1	Chip select for IC1
13	CS2	Chip select for IC2
14	RST	Reset signal
15	R/W	H/L Read/write
16	D/I	H/L H: Data, L: Instruction code
17	E	H/L Enable signal
18	Vee	Negative voltage output
19(A)	LED+	Power supply for BKL(4.2V)
20(K)	LED-	Power supply for BKL(GND)

**ABSOLUTE MAXIMUM RATINGS**

ITEM	SYMBOL	MIN	MAX	UNIT
POWER SUPPLY (LOGIC)	Vdd	-0.3	7.0	V
POWER SUPPLY (LCD)	V0	Vdd -19.0	Vdd +0.3	V
INPUT VOLTAGE	Vin	-0.3	Vdd +0.3	V

**ELECTRONICAL CHARACTERISTICS**

ITEM	SYMBOL	CONDITION	STANDARD			UNIT
			MIN	TYP	MAX	
Input voltage	Vdd	+5V	4.7	5.0	5.5	V
Supply current	Idd	Vdd=5V	---	8	---	mA
Recommended LCD driving voltage for normal temp version module	Vdd-V0	0 °C	---	9.8	---	V
		25 °C	---	9.5	---	
		50 °C	---	9.3	---	
LED forward voltage	V <sub>F</sub>	25 °C	---	4.2	4.5	V
LED forward current	I <sub>F</sub>	25 °C	---	240	---	mA

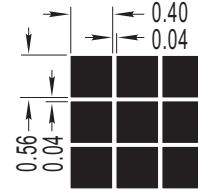
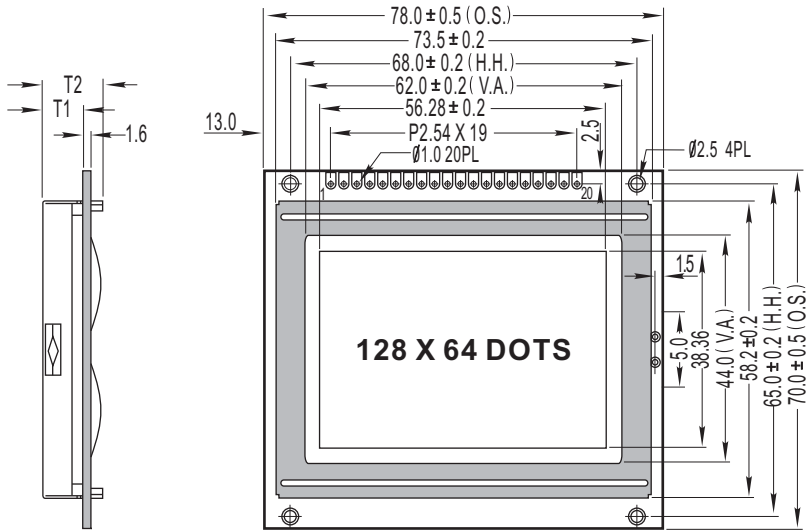

ITEM	T1	T2	UNIT
LED backlight	10.2	15.0	mm
EL or without backlight	5.0	10.0	mm

\* O.S.=Overall Size V.A.=Viewing Area H.H.=Hole -Hole

**BLOCK DIAGRAM**

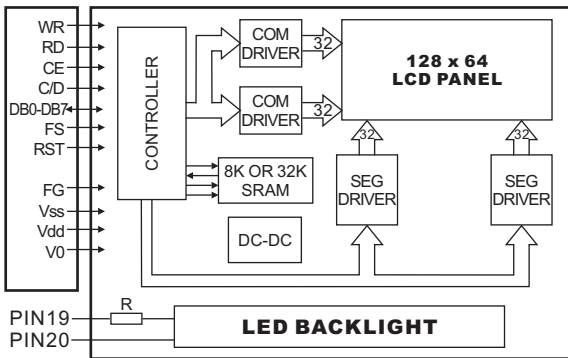

**FEATURE**

1. 128X64 dots graphic LCD module
2. Built- in controller (T6963C)
3. +5V power supply
4. STN LCD panel, 1/64 duty cycle

**MECHANICAL SPECIFICATIONS**

PARAMETER	VALUE	UNIT
DOT NUMBER	128W X 64H	—
OVERALL SIZE	78.00W X 70.00H	mm
VIEWING AREA	62.00W X 44.00H	mm
HOLE - HOLE	68.00W X 65.00H	mm
DOT SIZE	0.40W X 0.56H	mm
DOT PITCH	0.04W X 0.04H	mm

**PIN ASSIGNMENT**

PIN	SYMBOL	FUNCTION
1	FG	Frame ground
2	Vss	GND
3	Vdd	Power Supply
4	V0	Operating voltage for LCD
5	/WR	Write enable signal
6	/RD	Read enable signal
7	/CE	Chip enable signal
8	C/D	H: Instruction , L: Data
9	/RST	Reset signal
10 to 17	DB0 to DB7	H/L Data bus line
18	FS	Font selection
19(A)	LED+	Power supply for BKL(4.2V)
20(K)	LED-	Power supply for BKL(GND)

**ABSOLUTE MAXIMUM RATINGS**

ITEM	SYMBOL	MIN	MAX	UNIT
POWER SUPPLY (LOGIC)	Vdd	-0.3	7.0	V
POWER SUPPLY (LCD)	V0	Vdd-19.0	Vdd+0.3	V
INPUT VOLTAGE	Vin	-0.3	Vdd+0.3	V

**ELECTRONICAL CHARACTERISTICS**

ITEM	SYMBOL	CONDITION	STANDARD			UNIT
			MIN	TYP	MAX	
Input voltage	Vdd	+5V	4.7	5.0	5.5	V
Supply current	Idd	Vdd=5V	---	4.5	6.5	mA
Recommended LCD driving voltage for normal temp version module	Vdd-V0	0 °C	---	9.8	---	V
		25 °C	---	9.5	---	
		50 °C	---	9.3	---	
LED forward voltage	V <sub>F</sub>	25 °C	---	4.2	4.6	V
LED forward current	I <sub>F</sub>	25 °C	---	240	---	mA

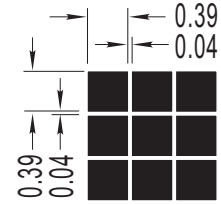
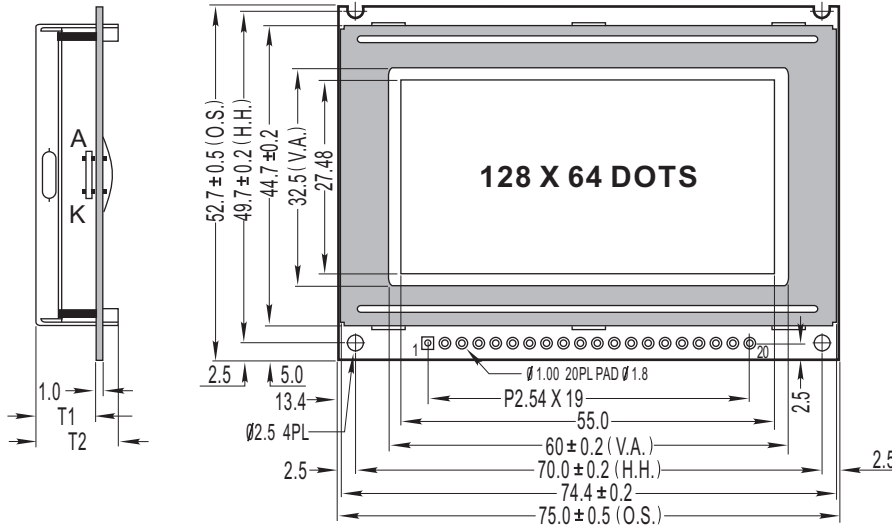

ITEM	T1	T2	UNIT
LED backlight	8.8	13.0	mm
EL or without backlight	5.4	9.0	mm

\* O.S.=Overall Size V.A.=Viewing Area H.H.=Hole -Hole

**BLOCK DIAGRAM**

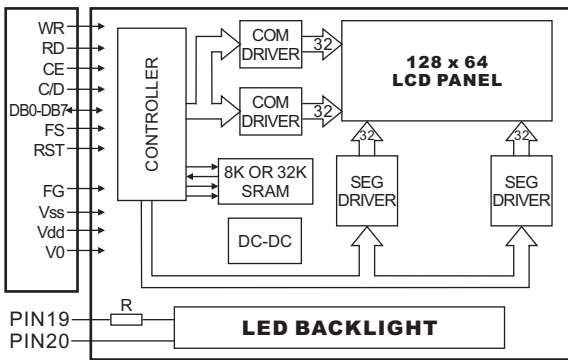

**FEATURE**

1. 128X64 dots graphic LCD module
2. Built- in controller (T6963C)
3. +5V power supply
4. STN LCD panel, 1/64 duty cycle

**MECHANICAL SPECIFICATIONS**

PARAMETER	VALUE	UNIT
DOT NUMBER	128W X 64H	—
OVERALL SIZE	75.00W X 52.70H	mm
VIEWING AREA	60.00W X 32.50H	mm
HOLE - HOLE	70.00W X 49.70H	mm
DOT SIZE	0.39W X 0.39H	mm
DOT PITCH	0.04W X 0.04H	mm

**PIN ASSIGNMENT**

PIN	SYMBOL	FUNCTION
1	FG	Frame ground
2	Vss	GND
3	Vdd	Power Supply
4	V0	Operating voltage for LCD
5	/WR	Write enable signal
6	/RD	Read enable signal
7	/CE	Chip enable signal
8	C/D	H: Instruction , L: Data
9	/RST	Reset signal
10 to 17	DB0 to DB7	H/L Data bus line
18	FS	Font selection
19(A)	LED+	Power supply for BKL(4.2V)
20(K)	LED-	Power supply for BKL(GND)

**ABSOLUTE MAXIMUM RATINGS**

ITEM	SYMBOL	MIN	MAX	UNIT
POWER SUPPLY (LOGIC)	Vdd	-0.3	7.0	V
POWER SUPPLY (LCD)	V0	Vdd-19.0	Vdd+0.3	V
INPUT VOLTAGE	Vin	-0.3	Vdd+0.3	V

**ELECTRONICAL CHARACTERISTICS**

ITEM	SYMBOL	CONDITION	STANDARD			UNIT
			MIN	TYP	MAX	
Input voltage	Vdd	+5V	4.7	5.0	5.5	V
Supply current	Idd	Vdd=5V	---	4.5	6.5	mA
Recommended LCD driving voltage for normal temp version module	Vdd-V0	0 °C	---	9.8	---	V
		25 °C	---	9.5	---	
		50 °C	---	9.3	---	
LED forward voltage	V <sub>F</sub>	25 °C	---	4.2	4.6	V
LED forward current	I <sub>F</sub>	25 °C	---	250	---	mA

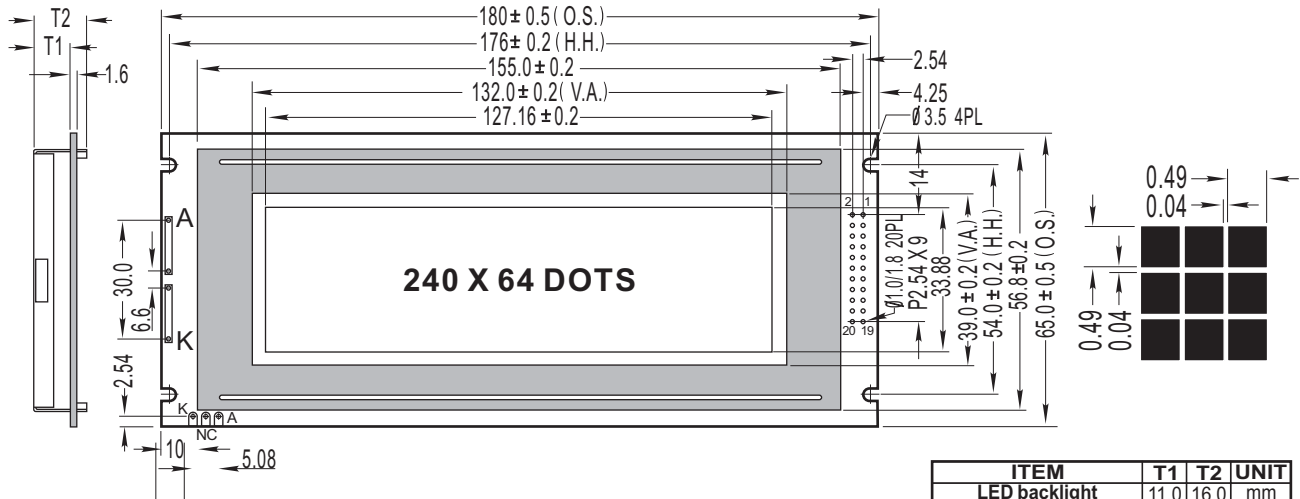

\* O.S.=Overall Size V.A.=Viewing Area H.H.=Hole -Hole

ITEM	T1	T2	UNIT
LED backlight	11.0	16.0	mm
EL or without backlight	4.8	10.0	mm

**BLOCK DIAGRAM**

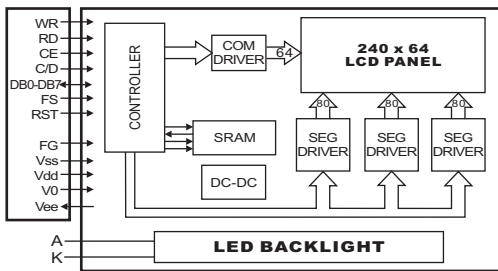

**FEATURE**

1. 240X64 dots graphic LCD module
2. Built-in controller (T6963C)
3. +5V power supply
4. STN LCD panel, 1/64 duty cycle

**MECHANICAL SPECIFICATIONS**

DOT NUMBER	240W X 64H	—
OVERALL SIZE	180.00W X 65.00H	mm
VIEWING AREA	134.00W X 40.40H	mm
HOLE - HOLE	176.00W X 54.00H	mm
DOT SIZE	0.49W X 0.49H	mm
DOT PITCH	0.04W X 0.04H	mm

**PIN ASSIGNMENT**

PIN	SYMBOL	FUNCTION
1	FG	Frame ground
2	Vss	GND
3	Vdd	Power Supply
4	V0	Contrast adjustment
5	/WR	Write enable signal
6	/RD	Read enable signal
7	/CE	Chip enable signal
8	C/D	H: Instruction , L: Data
9	Vee	Operating voltage for LCD
10	RST	Reset signal
11 to 18	DB0 to DB7	H/L Data bus line
19	FS	Font selection
20	N/A	No Connection
A	LED+	Power supply for BKL
K	LED-	Power supply for BKL

**ABSOLUTE MAXIMUM RATINGS**

ITEM	SYMBOL	MIN	MAX	UNIT
POWER SUPPLY (LOGIC)	Vdd	-0.3	7.0	V
POWER SUPPLY (LCD)	V0	Vdd -30	Vdd +0.3	V
INPUT VOLTAGE	Vin	-0.3	Vdd +0.3	V

**ELECTRONICAL CHARACTERISTICS**

ITEM	SYMBOL	CONDITION	STANDARD			UNIT
			MIN	TYP	MAX	
Input voltage	Vdd	+5V	4.7	5.0	5.5	V
Supply current	Idd	Vdd=5V	---	10	---	mA
Recommended LCD driving voltage for normal temp version module	Vdd-V0	0 °C	---	13.0	---	V
		25 °C	---	12.5	---	
		50 °C	---	12.0	---	
LED forward voltage	V <sub>F</sub>	25 °C	---	---	---	V
LED forward current	I <sub>F</sub>	25 °C	---	---	---	mA

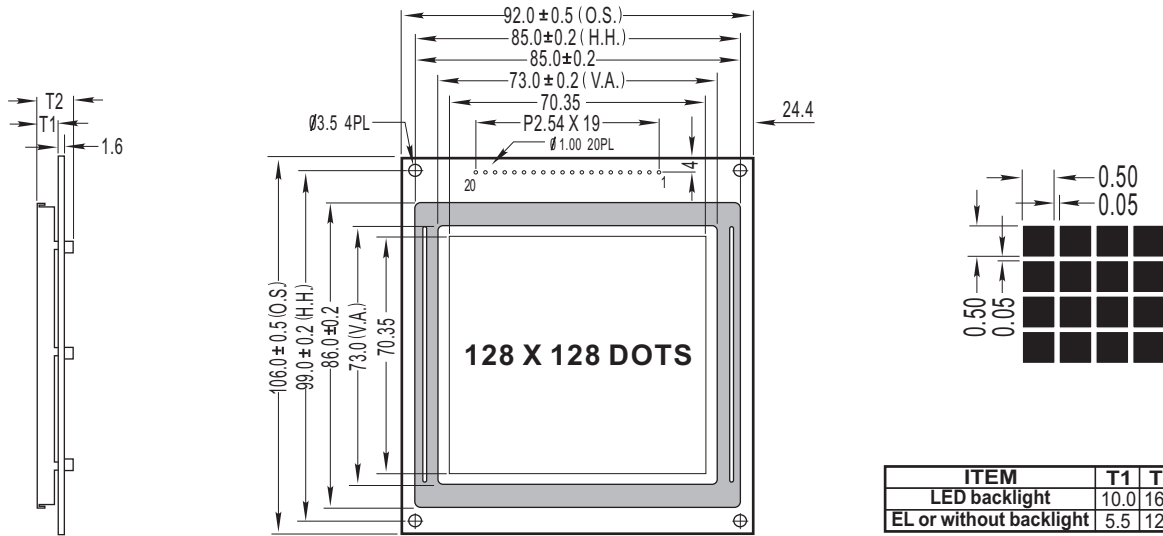

ITEM	T1	T2	UNIT
LED backlight	10.0	16.5	mm
EL or without backlight	5.5	12.0	mm

\* O.S.=Overall Size V.A.=Viewing Area H.H.=Hole -Hole

**BLOCK DIAGRAM**

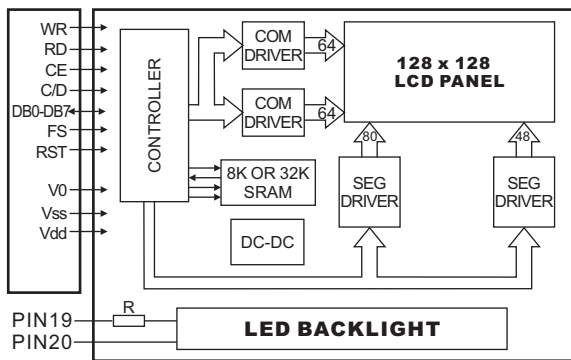

**FEATURE**

1. 128X128 dots graphic LCD module
2. Built-in controller (T6963C)
3. +5V power supply
4. STN LCD panel, 1/128 duty cycle

**MECHANICAL SPECIFICATIONS**

PARAMETER	VALUE	UNIT
DOT NUMBER	128W X 128H	—
OVERALL SIZE	92.00W X 106.00H	mm
VIEWING AREA	73.00W X 73.00H	mm
HOLE - HOLE	85.00W X 99.00H	mm
DOT SIZE	0.50W X 0.50H	mm
DOT PITCH	0.05W X 0.05H	mm

**PIN ASSIGNMENT**

PIN	SYMBOL	FUNCTION
1	FG	Frame ground
2	Vss	GND
3	Vdd	Power Supply
4	V0	Operating voltage for LCD
5	/WR	Write enable signal
6	/RD	Read enable signal
7	/CE	Chip enable signal
8	C/D	H: Instruction , L: Data
9	/RST	Reset signal
10 to 17	DB0 to DB7	H/L Data bus line
18	FS	Font selection
19(A)	LED+	Power supply for BKL(4.2V)
20(K)	LED-	Power supply for BKL(GND)

**ABSOLUTE MAXIMUM RATINGS**

ITEM	SYMBOL	MIN	MAX	UNIT
POWER SUPPLY (LOGIC)	Vdd	-0.3	7.0	V
POWER SUPPLY (LCD)	V0	Vdd-30.0	Vdd+0.3	V
INPUT VOLTAGE	Vin	-0.3	Vdd+0.3	V

**ELECTRONICAL CHARACTERISTICS**

ITEM	SYMBOL	CONDITION	STANDARD			UNIT
			MIN	TYP	MAX	
Input voltage	Vdd	+5V	4.7	5.0	5.5	V
Supply current	Idd	Vdd=5V	---	10	---	mA
Recommended LCD driving voltage for normal temp version module	Vdd-V0	0 °C	---	19.5	---	V
		25 °C	---	19.0	---	
		50 °C	---	18.0	---	
LED forward voltage	V <sub>F</sub>	25 °C	---	4.2	4.5	V
LED forward current	I <sub>F</sub>	25 °C	---	530	---	mA



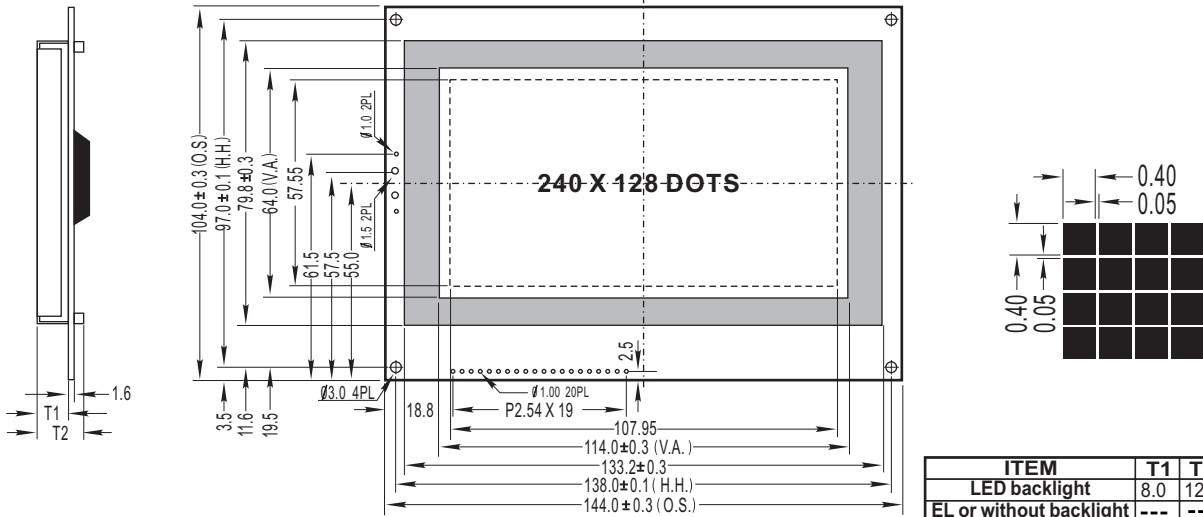

ITEM	T1	T2	UNIT
LED backlight	8.0	12.1	mm
EL or without backlight	---	---	mm

\* O.S.=Overall Size V.A.=Viewing Area H.H.=Hole-Hole

**BLOCK DIAGRAM**

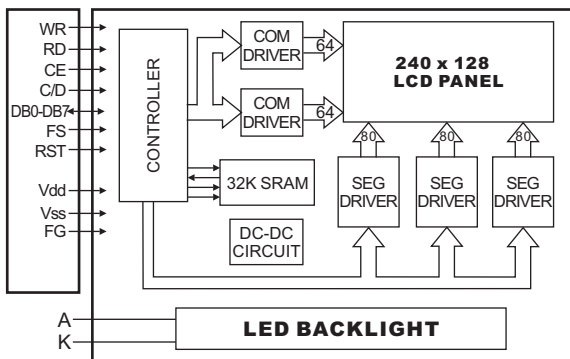

**FEATURE**

1. 240 X128 dots graphic LCD module
2. Built-in controller (T6963C)
3. +5V power supply
4. STN / FSTN LCD panel, 1/128 duty cycle

**MECHANICAL SPECIFICATIONS**

PARAMETER	VALUE	UNIT
DOT NUMBER	240 W X 128H	—
OVERALL SIZE	144.00W X 104.00H	mm
VIEWING AREA	114.00W X 64.00H	mm
HOLE - HOLE	138.00W X 97.00H	mm
DOT SIZE	0.40W X 0.40H	mm
DOT PITCH	0.05W X 0.05H	mm

**PIN ASSIGNMENT**

PIN	SYMBOL	FUNCTION
1	Vee	Negative Voltage Output
2	Vss	GND
3	Vdd	Power Supply
4	V0	Operating voltage for LCD
5	/WR	Write enable signal
6	/RD	Read enable signal
7	/CE	Chip enable signal
8	C/D	H: Instruction , L: Data
9	/RST	Reset signal
10 to 17	DB0 to DB7	H/L Data bus line
18	FS	Font selection
19(A)	LED+	Power supply for BKL(4.2V)
20(K)	LED-	Power supply for BKL(GND)

**ABSOLUTE MAXIMUM RATINGS**

ITEM	SYMBOL	MIN	MAX	UNIT
POWER SUPPLY (LOGIC)	Vdd	-0.3	7.0	V
POWER SUPPLY (LCD)	V0	---	---	V
INPUT VOLTAGE	Vin	-0.3	Vdd+0.3	V

**ELECTRONICAL CHARACTERISTICS**

ITEM	SYMBOL	CONDITION	STANDARD			UNIT
			MIN	TYP	MAX	
Input voltage	Vdd	+5V	4.7	5.0	5.5	V
Supply current	Idd	Vdd=5V	---	26	---	mA
Recommended LCD driving voltage for normal temp version module	Vdd-V0	0 °C	---	18.0	---	V
		25 °C	---	18.5	---	
		50 °C	---	19.0	---	
LED forward voltage	V <sub>F</sub>	25 °C	---	---	---	V
LED forward current	I <sub>F</sub>	25 °C	---	---	---	mA

## **X-ON Electronics**

Largest Supplier of Electrical and Electronic Components

*Click to view similar products for [Fordata](#) manufacturer:*

Other Similar products are found below :

[FC1602L00-FHYBW-51\\*R](#) [FC0801A01-FHYBW-51\\*K](#) [FC2004C03-NSWBBW-91\\*E](#) [FC1602N01-FHYBW-51\\*K](#) [FC1602N04-FHYBW-91\\*E](#) [FC2004C03-FHYBW-91\\*E](#) [FC1602B01-FHYBW-51SK](#) [FC1602B04-FHYBW-91\\*E](#)