

FORESEE[®]

Industrial eMMC Datasheet

A-00032

FEMDRW032G-88A19

FEMDRW064G-88A19

FEMDRW128G-88A19

Version 1.0



LONGSYS ELECTRONICS RESERVES THE RIGHT TO CHANGE PRODUCTS, INFORMATION AND SPECIFICATIONS WITHOUT NOTICE.

Products and specifications discussed herein are for reference purposes only. All information discussed herein is provided on an "AS IS" basis, without warranties of any kind. All brand names, trademarks and registered trademarks belong to their respective owners. This document and all information discussed herein remain the sole and exclusive property of Longsys Electronics. No license of any patent, copyright, mask work, trademark or any other intellectual property right is granted by one party to the other party under this document, by implication, estoppel or other-wise.

For updates or additional information about Longsys products, contact your nearest Longsys office.

© 2020 Shenzhen Longsys Electronics Co., Ltd. All rights reserved.

Revision History

Rev.	Date	Changes	Editor
1.0	2020/05/11	Document Create.	MSG

Longsys Confidential For SZLCS

CONTENTS

Revision History	2
CONTENTS	3
1 INTRODUCTION	5
2 PRODUCT LIST	5
3 KEY FEATURES	5
4 PACKAGE CONFIGURATIONS	6
4.1 Ball Pin Configuration	6
4.2 Package Dimension	8
5 PRODUCT SPECIFICATIONS.....	9
5.1 Write/Read Performance	9
5.2 Power Consumption	9
5.2.1 Active Power Consumption During Operation	9
5.2.2 Low power mode (stand-by)	10
5.2.3 Low power mode (sleep)	10
6 Technical Notes.....	11
6.1 Functional Description	11
6.2 Interface timing mode	12
6.3 System Architecture	12
6.4 Partition Management	13
6.5 Automatic Sleep Mode.....	15
6.6 Sleep (CMD5)	16
6.7 H/W Reset operation	16
6.8 Initial Data Acceleration(IDA)	16
6.9 High-speed mode selection	17
6.10 Bus width selection	17
6.11 Partition Configuration	17

- 6.12 Reference Schematics 18
- 7 REGISTER VALUE 19
 - 7.1 CID register 19
 - 7.2 CSD register 20
 - 7.3 Extended CSD register 22
 - 7.4 OCR Register 30
 - 7.5 Field firmware update(FFU) 31
 - 7.5.1 Longsys eMMC (FEMDRWxxxG-88A19) Field F/W update flow - CMD sequence 31
 - 7.5.2 SUPPORTED_MODE [493] (Read Only) 31
 - 7.5.3 FFU_FEATURE [492] (Read Only) 32
 - 7.5.4 FFU_ARG [490-487] (Read Only) 32
 - 7.5.5 FW_CONFIG[169] (R/W) 32
 - 7.5.6 FFU_STATUS [26] (R/W/E_P) 32
 - 7.5.7 OPERATION_CODES_TIMEOUT[491](Read Only) 33
 - 7.5.8 MODE_OPERATION_CODES[29] (W/E_P) 33
 - 7.6 S.M.A.R.T. Health Report 33

1 INTRODUCTION

FORESEE eMMC is an embedded storage solution designed in the BGA package. The FORESEE eMMC consists of NAND flash and eMMC controller. The controller could manage the interface protocols, wearleveling, bad block management and ECC.

FORESEE eMMC has high performance at a competitive cost, high quality and low power consumption, and eMMC is compatible with JEDEC standard eMMC 5.1 specifications.

2 PRODUCT LIST

Table 1. Product List

Capacity	Part Number	NAND Flash Type	User Density	Package Size(mm)	Package Type
----------	-------------	-----------------	--------------	------------------	--------------

32GB	FEMDRW032G-88A19	256Gb x1	28.8GB	11.5 × 13.0 × 1.0	153 FBGA
64GB	FEMDRW064G-88A19	256Gb x2	57.6GB	11.5 × 13.0 × 1.0	153 FBGA
128GB	FEMDRW128G-88A19	256Gb x4	115.2GB	11.5 × 13.0 × 1.2	153 FBGA

- Storage without operation: -40°C ~ +85°C

3 KEY FEATURES

- **eMMC5.1 specification compatibility**

- Backward compatible to eMMC4.41/4.5/5.0

- **Bus mode**

- Data bus width: 1 bit (default), 4 bits, 8 bits
- Data transfer rate: up to 400MB/s (HS400)
- MMC I/F Clock frequency: 0~200MHz

- **Operating voltage range**

- V_{CC}(NAND): 2.7 ~ 3.6V
- V_{CCQ}(Controller): 1.7 ~ 1.95V / 2.7 ~ 3.6V

- **Temperature**

- Operation: -40°C ~ +85°C

- **Sudden-Power-Loss safeguard**

- **Hardware ECC engine**

- **Unique firmware backup mechanism · Global-wear-leveling · Supported features.**

- HS400, HS200
- Partitioning, RPMB
- Boot feature, boot partition
- HW Reset/SW Reset
- Discard, Trim, Erase, Sanitize
- Background operations, HPI
- Enhanced reliable write
- S.M.A.R.T. Health Report
- FFU
- Sleep / awake

- **Others**

- Compliance with the RoHS Directive

4 PACKAGE CONFIGURATIONS

4.1 Ball Pin Configuration

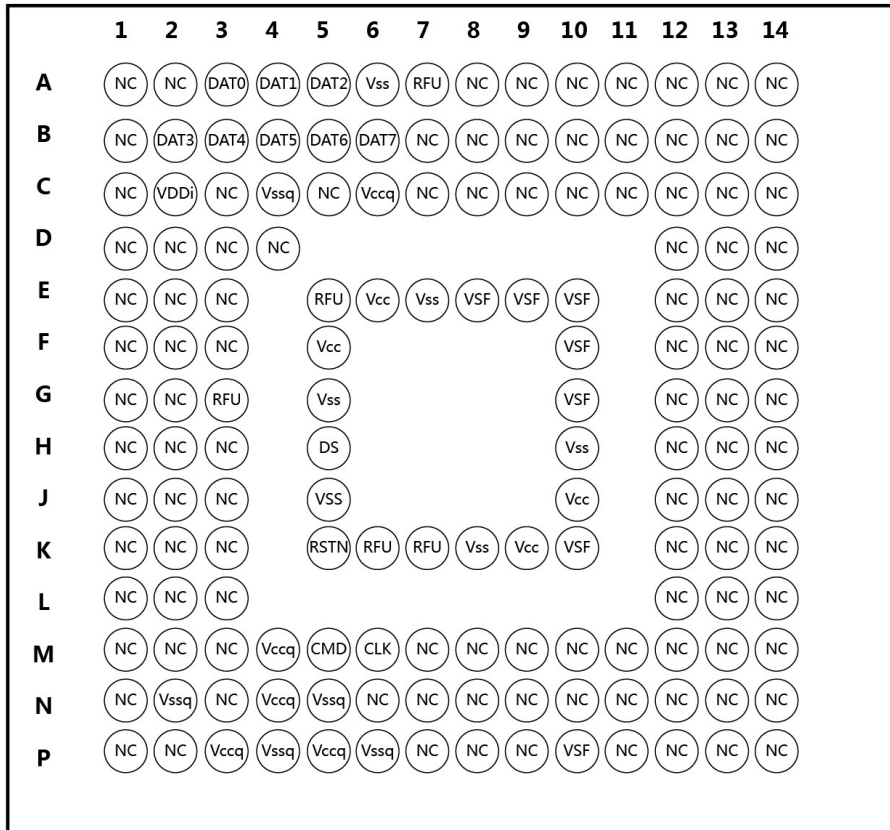

Figure 1. Ball Array (Top View through package)

Table 2. Ball Array Description

Pin No.	Pin Name	Description
A3	DAT0	These are bidirectional data signal. The DAT signals operate in push-pull mode. Only the device or the host is driving these signals at a time. By default, after power up or reset, only DAT0 is used for data transfer. A wider data bus can be configured for data transfer, using either DAT0-DAT3 or DAT0-DAT7, by the eMMC host controller. The eMMC device includes internal pull-ups for data lines DAT1-DAT7. Immediately after entering the 4-bit mode, the device disconnects the internal pull ups of lines DAT1, DAT2, and DAT3. Correspondingly, immediately after entering to the 8-bit mode the device disconnects the internal pull-ups of lines DAT1-DAT7
A4	DAT1	
A5	DAT2	
B2	DAT3	
B3	DAT4	
B4	DAT5	
B5	DAT6	
B6	DAT7	
Pin No.	Pin Name	Description

K5	RSTN	Hardware Reset Input
C6	VCCQ	VCCQ is the power supply line for host interface, have two power mode: High power mode:2.7V~3.6V; Lower power mode:1.7V~1.95V.
M4	VCCQ	
N4	VCCQ	
P3	VCCQ	
P5	VCCQ	
E6	VCC	
F5	VCC	
J10	VCC	
K9	VCC	
C2	VDDi	VDDi is internal power node, not the power supply. Connect 1uF capacitor VDDi to ground.
M5	CMD	This signal is a bidirectional command channel used for device initialization and command transfer. Commands are sent from the host to the device, and responses are sent from the device to the host. The CMD Signal has 2 operation modes: open drain for initialization, and push-pull for command transfer.
H5	DS	Data Strobe signal. Newly assigned pin for HS400 mode. Data Strobe is generated from eMMC to host. In HS400 mode, read data and CRC response are synchronized with Data Strobe.
M6	CLK	Each cycle of this signal directs a one-bit transfer on the command and either a one-bit (1x) or a twobits transfer (2x) on all the data lines.
J5	VSS	Ground connections
A6	VSS	
C4	VSS	
E7	VSS	
G5	VSS	
H10	VSS	
K8	VSS	
N2	VSS	
N5	VSS	
P4	VSS	
P6	VSS	

4.2 Package Dimension

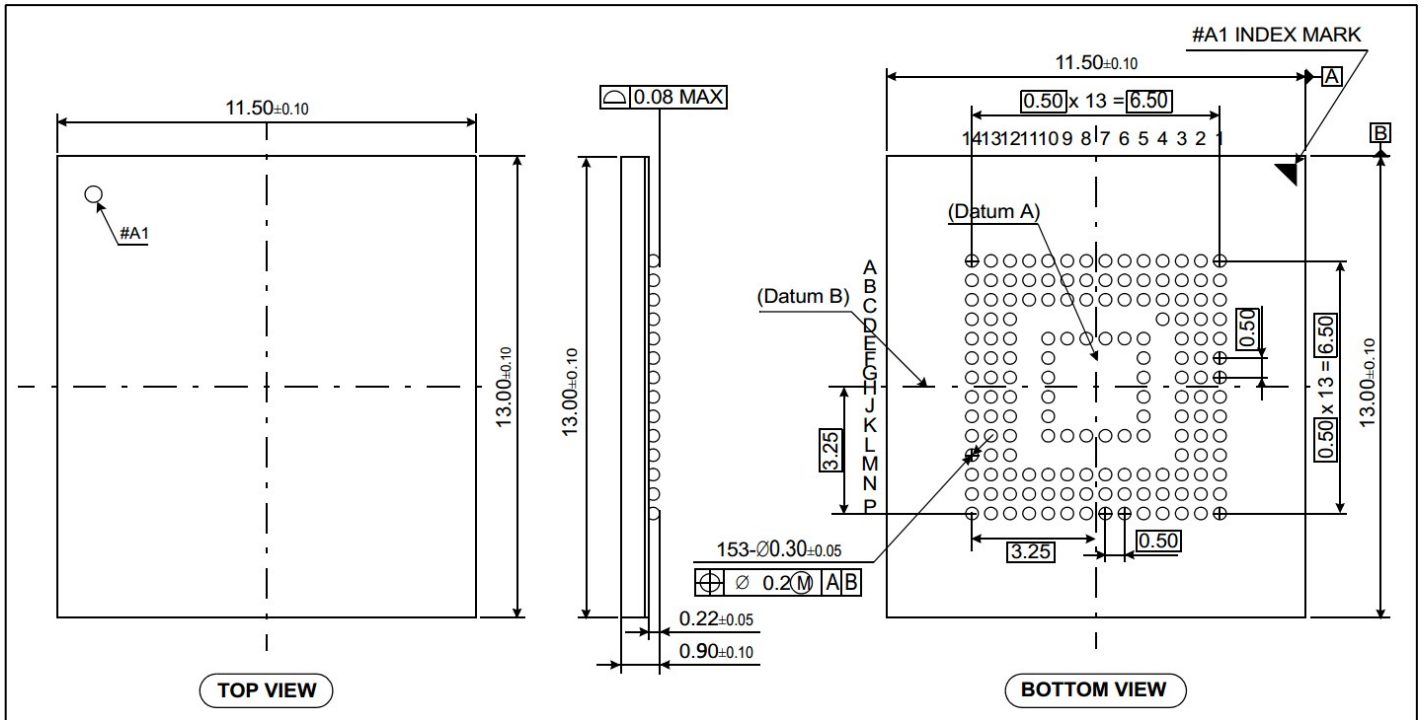

Figure 2. 11.5mm x 13.0mm x 1.0mm Package Dimension

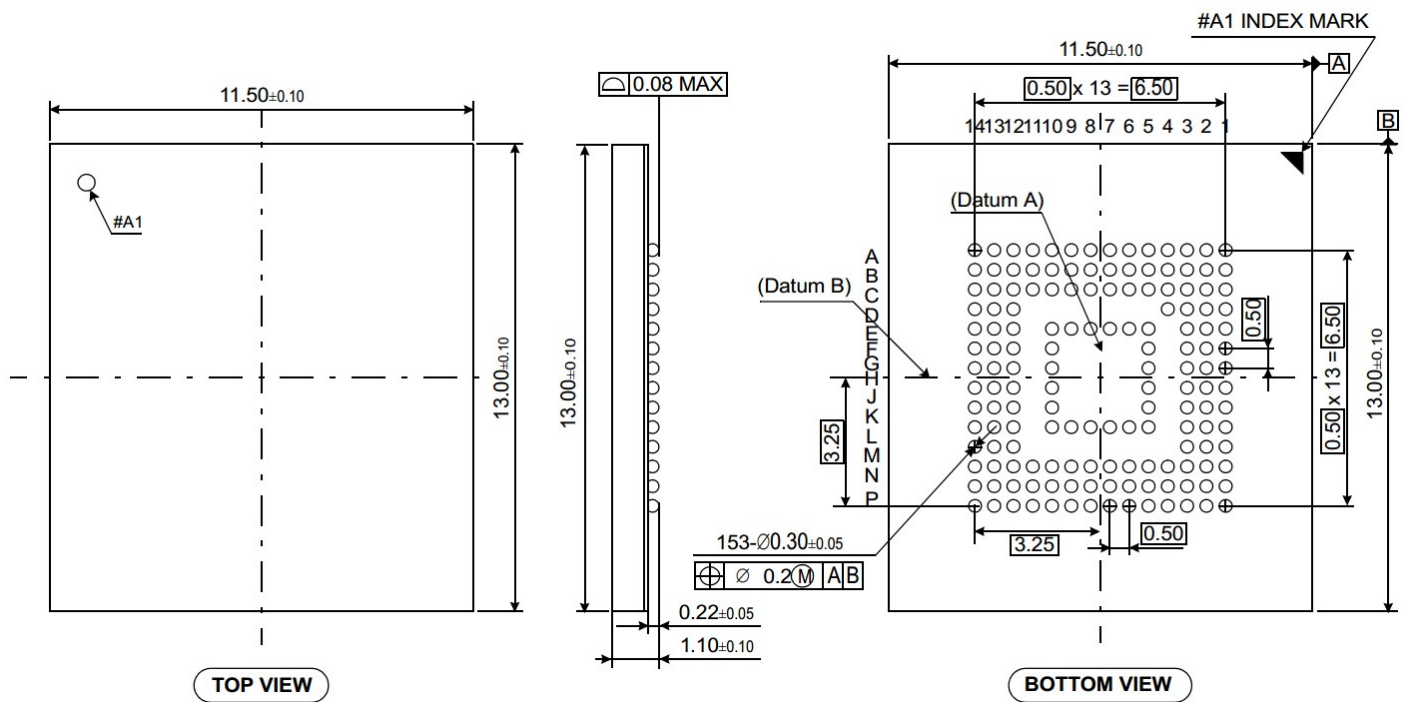

Figure 3. 11.5mm x 13.0mm x 1.2mm Package Dimension

5 PRODUCT SPECIFICATIONS

5.1 Write/Read Performance

Table 3. Write/Read Performance

Part Number	Write	Read
FEMDRW032G-88A19	Up to 130 MB/s	Up to 245 MB/s
FEMDRW064G-88A19	Up to 145 MB/s	Up to 245 MB/s
FEMDRW128G-88A19	Up to 150 MB/s	Up to 245 MB/s

Note:

Test Condition: Bus width x8, 200MHz DDR, 512KB data transfer, w/o file system overhead, measured on internal board.

Test tool: uBOOT (Without O/S)

Chunk size: 1MB

Test area: 100MB/ Full-range of LBA.

5.2 Power Consumption

5.2.1 Active Power Consumption During Operation

Table 4. Active Power Consumption During Operation

Part Number	I _{cc}	I _{ccq}
FEMDRW032G-88A19	70mA	120mA
FEMDRW064G-88A19	80mA	120mA
FEMDRW128G-88A19	100mA	120mA

Note:

Power Measurement conditions: Bus configuration =x8 @200MHz DDR, 23°C.

VCC = 3.3V & VCCQ = 1.8V.

The measurement for max RMS current is the average RMS current consumption over a period of 100ms.

5.2.2 Low power mode (stand-by)

Table 5. Low power mode (stand-by)

Part Number	I _{cc}	I _{ccq}
FEMDRW032G-88A19	70uA	150uA
FEMDRW064G-88A19	80uA	150uA
FEMDRW128G-88A19	100uA	150uA

Note:

Power Measurement conditions: Bus configuration =x8 @200MHz DDR, 23 °C.

Standby: NAND Flash VCC & Controller VCCQ power supply is switched on.

The measurement for max RMS current is the average RMS current consumption over a period of 100ms.

5.2.3 Low power mode (sleep)

Table 6. Low power mode (sleep)

Part Number	I _{cc}	I _{ccq}
FEMDRW032G-88A19	0	150uA
FEMDRW064G-88A19	0	150uA
FEMDRW128G-88A19	0	150uA

Note:

Power Measurement conditions: Bus configuration =x8 @200MHz DDR, 23 °C.

Sleep: NAND Flash VCC power supply is switched off (Controller VCCQ on)

The measurement for max RMS current is the average RMS current consumption over a period of 100ms.

6 Technical Notes

6.1 Functional Description

FORESEE eMMC with powerful L2P (Logical to Physical) NAND Flash management algorithm provides unique functions:

- **Host independence from details of operating NAND flash**

The eMMC Controller already includes Flash management technologies such as data storage and retrieval, defect handling and diagnostics, and power management. Host can be free from considering about NAND Flash data operating.

- **Internal ECC to correct defect in NAND flash**

The hardware error correction code (ECC) function, which can prevent data corruption data corruption is included in the eMMC controller.

● Sudden-Power-Loss Safeguard

To prevent from data loss, a mechanism named Sudden-Power-Loss Safeguard is added in the eMMC. In the case of sudden power-failure, the eMMC would work properly after power cycling.

● Global-wear-leveling

To achieve the best stability and device endurance, this eMMC equips the Global Wear Leveling algorithm. It ensures that not only normal area, but also the frequently accessed area, such as FAT, would be programmed and erased evenly.

● IDA (Initial Data Acceleration)

The eMMC prevents the pre-burned data from data-loss with IDA, in case of our customer had pre-burned data to eMMC, before the eMMC being SMT.

● Cache

The eMMC enhanced the data written performance with Cache, with which our customer would get more endurance and reliability.

6.2 Interface timing mode

FORESEE eMMC support supports high speed DDR interface timing mode up to 400MB/s at 200MHz with 1.8V I/O supply.

Table 7. Device Type Value (EXT_CSD register : DEVICE_TYPE [196])

Bit	Device Type	Supportability
7	HS400 Dual Data Rate eMMC at 200 MHz – 1.2 V I/O	Not support
6	HS400 Dual Data Rate eMMC at 200 MHz – 1.8 V I/O	Support
5	HS200 Single Data Rate eMMC at 200 MHz - 1.2 V I/O	Not support
4	HS200 Single Data Rate eMMC at 200 MHz - 1.8 V I/O	Support
3	High-Speed Dual Data Rate eMMC at 52 MHz - 1.2 V I/O	Not support
2	High-Speed Dual Data Rate eMMC at 52 MHz - 1.8 V or 3.3 V I/O	Support
1	High-Speed eMMC at 52 MHz - at rated device voltage(s)	Support
0	High-Speed eMMC at 26 MHz - at rated device voltage(s)	Support

6.3 System Architecture

The eMMC can be operated in 1-bit, 4-bit, or 8-bit mode. NAND flash memory is managed by a controller inside, which manages ECC, wear leveling and bad block management. The eMMC provides easy integration with the host process that all flash management hassles are invisible to the host.

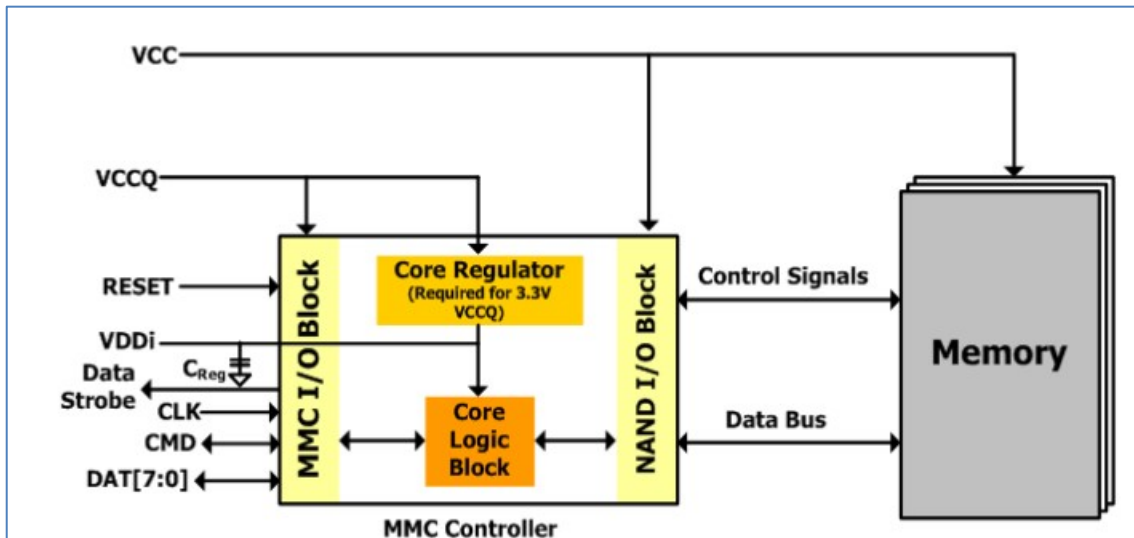

Figure 4. eMMC System Architecture

6.4 Partition Management

The embedded device offers also the possibility of configuring by the host additional split local memory partitions with independent addressable space starting from logical address 0x00000000 for different usage models. Default size of each Boot Area Partition is 4096 KB and can be changed by Vendor Command as multiple of 128KB. Boot area partition size is calculated as (128KB * BOOT_SIZE_MULTI) The size of Boot Area Partition 1 and 2 cannot be set independently and is set as same value Boot area partition which is enhanced partition. Therefore, memory block area scan is classified as follows:

- Factory configuration supplies boot partitions.
- The RPMB partition is 4MB.
- The host is free to configure one segment in the User Data Area to be implemented as enhanced storage media, and to specify its starting location and size in terms of Write Protect Groups. The attributes of this Enhanced User Data Area can be programmed only once during the device life-cycle (one-time programmable).
- Up to four General Purpose Area Partitions can be configured to store user data or sensitive data, or for other host usage models. The size of these partitions is a multiple of the write protect group. Size and attributes can be programmed once in device life-cycle (one-time programmable). Each of the General Purpose Area Partitions can be implemented with enhanced technological features.

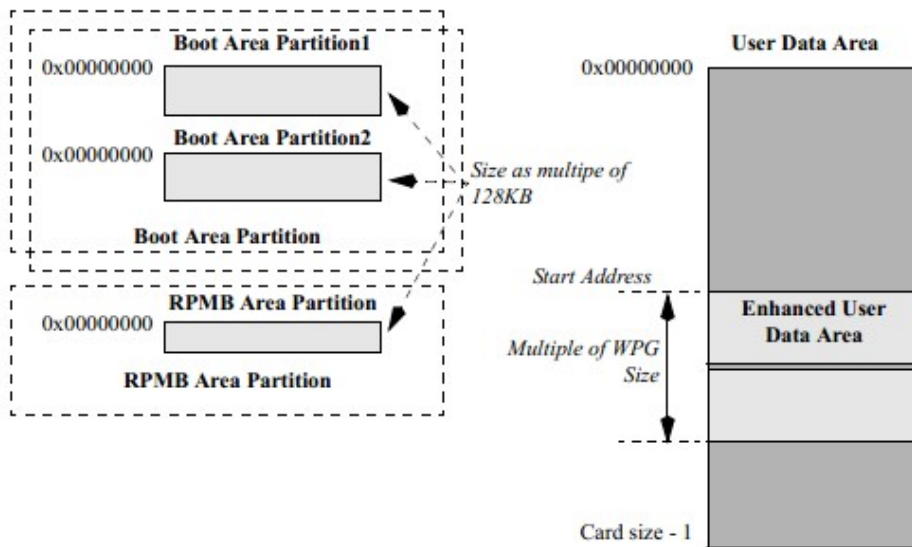

Figure 5. Partitions and user data area configuration

In boot operation mode, the master can read boot data from the slave (device) by keeping CMD line low or sending CMD0 with argument + 0xFFFFFFFF, before issuing CMD1. The data can be read from either boot area or user area depending on register setting.

Table 8. Boot ack, boot data and initialization Time

Timing Factor	Value
Boot ACK Time	< 50 ms
Boot Data Time	< 1 s
Initialization Time	< 1 s

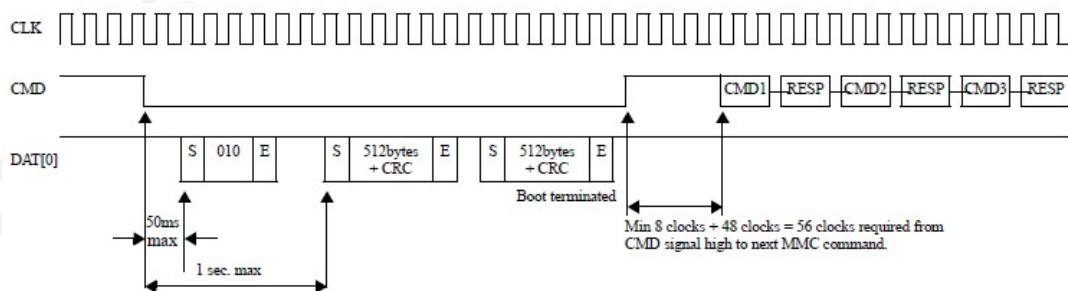

Figure 6. State diagram (boot mode)

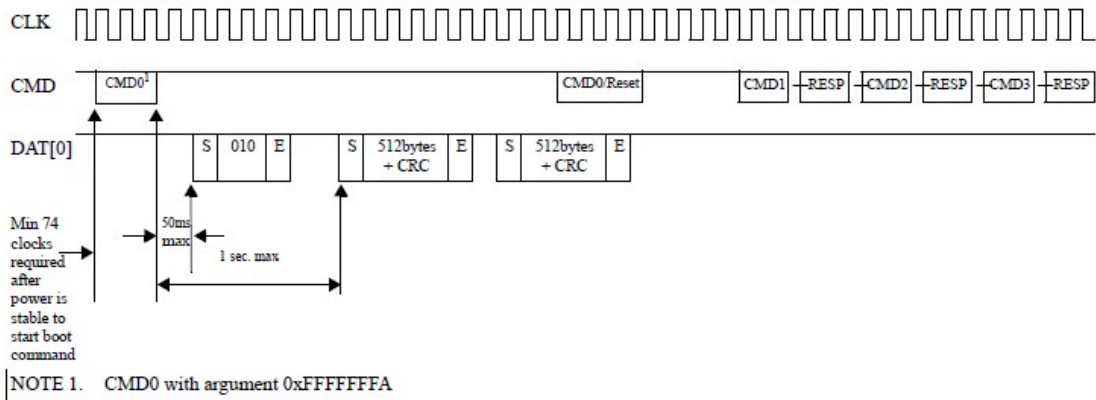

Figure 7. State diagram (alternative boot mode)

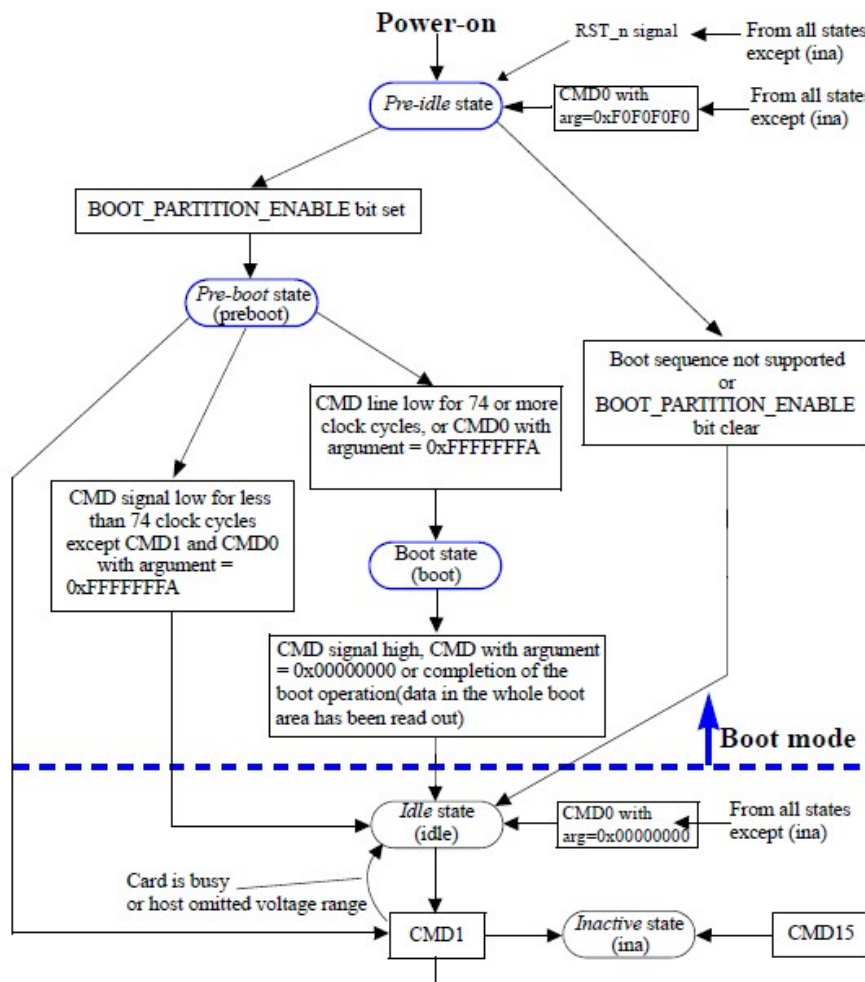

Figure 8. State diagram (boot mode) *

6.5 Automatic Sleep Mode

If host does not issue any command during certain duration (**1s**), after previously issued command is completed, the device enters “Power Saving mode” to reduce power consumption. At this time, commands arriving at the device while it is in power saving mode will be serviced in normal fashion. The below table explains the condition to enter and exit Auto Power Saving Mode

6.6 Sleep (CMD5)

A card may be switched between a Sleep state and a Standby state by SLEEP/AWAKE (CMD5). In the Sleep state the power consumption of the memory device is minimized. In this state the memory device reacts only to the commands RESET (CMD0 with argument of either 0x00000000 or 0xF0F0F0F0 or H/W reset) and SLEEP/AWAKE (CMD5). All the other commands are ignored by the memory device. The timeout for state transitions between Standby state and Sleep state is defined in the EXT_CSD register S_A_timeout. The maximum current consumptions during the Sleep state are defined in the EXT_CSD registers S_A_VCC and S_A_VCCQ. Sleep command: The bit 15 as set to 1 in SLEEP/ AWAKE (CMD5) argument. A wake command: The bit 15 as set to 0 in SLEEP/AWAKE (CMD5) argument.

6.7 H/W Reset operation

Device will detect the rising edge of RST_n signal to trigger internal reset sequence

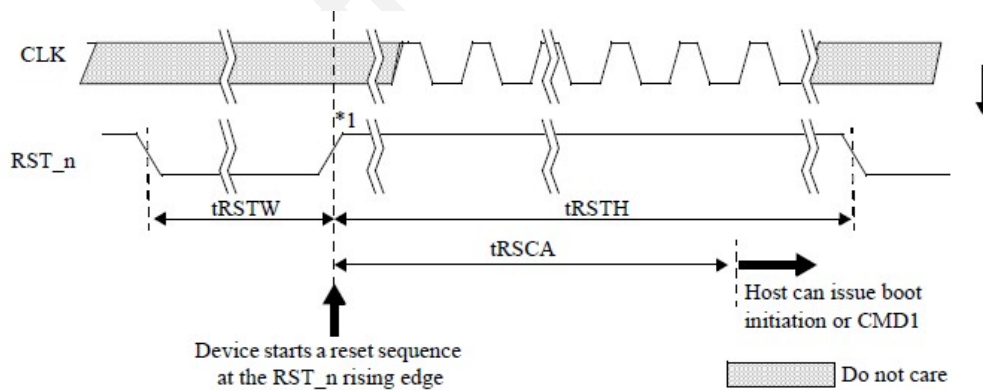

Figure 9. H/W reset waveform

6.8 Initial Data Acceleration(IDA)

In the case of pre-burn before SMT, it is recommended to limit the size of data pre-burned to the eMMC, please contact your agency for more information.

- The amount of data pre-burned (data written before SMT) is limited, it should be managed properly.

● **Maximum size for the data-written to IDA:**

Table 9. IDA Maximum Size

Part Number	Size limited for Pre-burned Data
FEMDRW032G-88A19	9.5GB
FEMDRW064G-88A19	18.5GB
FEMDRW128G-88A19	37.5GB

6.9 High-speed mode selection

After the host verifies that the card complies with version 4.0, or higher, of this standard, it has to enable the high-speed mode timing in the card, before changing the clock frequency to a frequency higher than 20MHz. For the host to change to a higher clock frequency, it has to enable the high-speed interface timing. The host uses the SWITCH command to write 0x01 to the HS_TIMING byte, in the Modes segment of the EXT_CSD register.

6.10 Bus width selection

After the host has verified the functional pins on the bus it should change the bus width configuration accordingly, using the SWITCH command. The bus width configuration is changed by writing to the BUS_WIDTH byte in the Modes Segment of the EXT_CSD register (using the SWITCH command to do so). After power-on, or software reset, the contents of the BUS_WIDTH byte is 0x00.

6.11 Partition Configuration

Table 10. Partition Configuration

Model	Area/Partition	Size (GB)	Size (MB)	Size (Sector)	Size (Byte)	Size (Hex, Byte)
FEMDRW032G-88A19	User	28.8GB	29600	60620800	31037849600	73A000000
	Boot Partition 1	-	4	8192	4194304	400000
	Boot Partition 2	-	4	8192	4194304	400000
	RPMB	-	4	8192	4194304	400000
FEMDRW064G-88A19	User	57.6GB	59000	120832000	61865984000	E67800000
	Boot Partition 1	-	4	8192	4194304	400000
	Boot Partition 2	-	4	8192	4194304	400000
	RPMB	-	4	8192	4194304	400000
FEMDRW128G-88A19	User	115.2GB	118000	241664000	123731968000	1CCF000000

Boot Partition 1	-	4	8192	4194304	400000
Boot Partition 2	-	4	8192	4194304	400000
RPMB	-	4	8192	4194304	400000

6.12 Reference Schematics

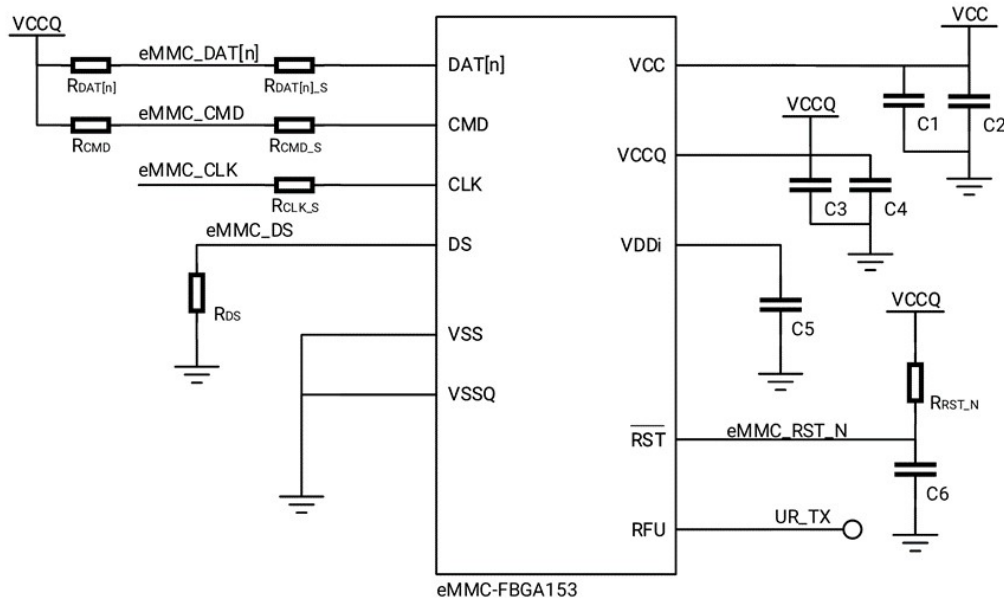

Figure 10. eMMC Reference Schematics Table 11.

Reference component parameter

Parameter	Symbol	Min	Typical	Max	Remark
Power of VCC	VCC	2.7V	3.3V	3.6V	Should be separated from VCCQ
Power of VCCQ (High Perf.)	VCCQ	1.7V	1.8V	1.95V	HS200/HS400
Power of VCCQ (Low Perf.)	VCCQ	2.7V	3.3V	3.6V	52MHz CLK SDR/DDR
DAT[n] Pull-Up Resistance	R _{DAT[n]}	10k Ω	--	100k Ω	DAT[n], n=0~7
CMD Pull-Up Resistance	R _{CMD}	4.7k Ω	--	100k Ω	
DS Pull-Down Resistance	R _{DS}	10k Ω	--	100k Ω	HS200/HS400
RST_N Pull-Up Resistance	R _{RST_N}	--	NC	--	Reserving for EVT
DAT[n] Serial Resistance	R _{DAT[n,S]}	--	0 Ω	33 Ω	Reserving for EVT
CMD Serial Resistance	R _{CMD,S}	--	0 Ω	33 Ω	Reserving for EVT
CLK Serial Resistance	R _{CLK,S}	--	0 Ω	33 Ω	Reserving for EVT
Power Coupling Capacitor 1	C1, C3	2.2 μ F	--	4.7 μ F	6.3V, X5R or higher classification
Power Coupling Capacitor 2	C2, C4	--	0.1 μ F	--	6.3V, X5R or higher classification

VDDi Coupling Capacitor	C5	0.1 μ F	1 μ F	--	6.3V, X5R or higher classification
RST_N Coupling Capacitor	C6	--	NC	--	6.3V, X5R or higher classification

Design note:

1. Coupling capacitor should be connected with VCC/VCCQ and VSS as closely as possible.
3. The VCC and VCCQ power should be separated.
4. LONGSYS recommends lay the VSS between the CLK and the Data lines.
5. For more details, please contact your technical support.

7 REGISTER VALUE

7.1 CID register

The Card Identification (CID) register is 128 bits wide. It contains the card identification information used during the card identification phase (protocol). Every individual flash or I/O card shall have a unique identification number. Every type of ROM card (defined by content) shall have a unique identification number.

The structure of the CID register is defined in the following sections.

Table 12. CID register

Name		Field	Width	CID-slice	CID Value	Remark
Manufacturer ID		MID	8	[127:120]	D6h	
Reserved		-	6	[119:114]	--	
Card/BGA		CBX	2	[113:112]	01h	BGA
OEM/Application ID		OID	8	[111:104]	03h	
Product name	FEMDRW032G-88A19	PNM	48	[103:56]	0x383841313942	88A19B
	FEMDRW064G-88A19				0x383841313943	88A19C
	FEMDRW128G-88A19				0x383841313944	88A19D
Product revision		PRV	8	[55:48]	--	
Product serial number		PSN	32	[47:16]	--	Not Fixed
Manufacturing date		MDT	8	[15:8]	--	Not Fixed
CRC7 checksum		CRC	7	[7:1]	--	Not Fixed
Not used, always '1'		-	1	[0:0]	--	

7.2 CSD register

The Card-Specific Data (CSD) register provides information on how to access the card contents. The CSD defines the data format, error correction type, maximum data access time, data transfer speed, whether the DSR register can be used etc. The programmable part of the register (entries marked by W or E, see below) can be changed by CMD27. The type of the CSD Registry entries coded as follows:

Table 13. CSD Register

Name	Field	Width	Cell Type	CSD-slice
CSD structure	CSD_STRUCTURE	2	R	[127:126]
System specification version	SPEC_VERS	4	R	[125:122]
Reserved	-	2	R	[121:120]
Data read access-time 1	TAAC	8	R	[119:112]
Data read access-time 2 in CLK cycles (NSAC*100)	NSAC	8	R	[111:104]
Max. bus clock frequency	TRAN_SPEED	8	R	[103:96]
Card command classes	CCC	12	R	[95:84]
Max. read data block length	READ_BLK_LEN	4	R	[83:80]
Partial blocks for read allowed	READ_BLK_PARTIAL	1	R	[79:79]
Write block misalignment	WRITE_BLK_MISALIGN	1	R	[78:78]
Read block misalignment	READ_BLK_MISALIGN	1	R	[77:77]
DSR implemented	DSR_IMP	1	R	[76:76]
Reserved	-	2	R	[75:74]
Device size	C_SIZE	12	R	[73:62]
Max. read current @V _{DD} min	VDD_R_CURR_MIN	3	R	[61:59]
Max. read current @V _{DD} max	VDD_R_CURR_MAX	3	R	[58:56]
Max. write current @V _{DD} min	VDD_W_CURR_MIN	3	R	[55:53]
Max. write current @V _{DD} max	VDD_W_CURR_MAX	3	R	[52:50]
Device size multiplier	C_SIZE_MULT	3	R	[49:47]
Erase group size	ERASE_GRP_SIZE	5	R	[46:42]
Erase group size multiplier	ERASE_GRP_MULT	5	R	[41:37]

Name	Field	Width	Cell Type	CSD-slice
Write protect group size	WP_GRP_SIZE	5	R	[36:32]
Write protect group enable	WP_GRP_MULT	1	R	[31:31]
Manufacturer default ECC	DEFAULT_ECC	2	R	[30:29]
Write speed factor	R2W_FACTOR	3	R	[28:26]
Max. write data block length	WRITE_BL_LEN	4	R	[25:22]
Partial blocks for write allowed	WRITE_BL_PARTIAL	1	R	[21:21]
Reserved	-	4	R	[20:17]
Content protection application	CONTENT_PROT_APP	1	R	[16:16]
File format group	FILE_FORMAT_GRP	1	R/W	[15:15]
Copy flag (OTP)	COPY	1	R/W	[14:14]
Permanent write protection	PERM_WRITE_PROTECT	1	R/W	[13:13]
Temporary write protection	TMP_WRITE_PROTECT	1	R/W/E	[12:12]
File format	FILE_FORMAT	2	R/W	[11:10]
ECC code	ECC	2	R/W/E	[9:8]
CRC	CRC	7	R/W/E	[7:1]
Not used, always '1'	-	1	-	[0:0]

7.3 Extended CSD register

The Extended CSD register defines the card properties and selected modes. It is 512 bytes long. The most significant 320 bytes are the Properties segment, which defines the card capabilities and cannot be modified by the host. The lower 192 bytes are the Modes segment, which defines the configuration the card is working in. These modes can be changed by the host by means of the SWITCH command.

Table 14. Extended CSD Register

Name	Field	Size	Type	Slice[bytes]	Value
Reserved*		6	-	[511:506]	-
Extended security error	EXT_SECURITY_ERR	1	R	[505]	0
Supported Command Sets	S_CMD_SET	1	R	[504]	1h

HPI Features	HPI_FEATURES	1	R	[503]	1h
Background operations support ¹	BKOPS_SUPPORT	1	R	[502]	1h
Max packed read command	MAX_PACKED_READS	1	R	[501]	3Fh
Max packed write command	MAX_PACKED_WRITES	1	R	[500]	3Fh
Data Tag Support	DATA_TAD_SUPPORT	1	R	[499]	1h
Tag Unit Size	TAG_UNIT_SIZE	1	R	[498]	3h
Tag Resource Size	TAG_RES_SIZE	1	R	[497]	0h
Context management capabilities	CONTEXT_CAPABILITIES	1	R	[496]	5h
Large Unit size ²	LARGE_UNIT_SIZE_M1	1	R	[495]	7h
Extended partitions attribute support	EXT_SUPPORT	1	R	[494]	3h
Supported modes	SUPPORTED_MODES	1	R	[493]	3h
FFU features	FFU_FEATURES	1	R	[492]	0h
Operation codes timeout	OPERATION_CODE_TIMEOUT	1	R	[491]	0h
FFU Argument	FFU_ARG	4	R	[490:487]	0h
Barrier support	BARRIER_SUPPORT	1	R	[486]	0h
Reserved*		177	-	[485:309]	-

Name	Field	Size	Type	Slice[bytes]	Value
CMDQ support	CMDQ_SUPPORT	1	W/R	[308]	1h
CMDQ depth	CMDQ_DEPTH	1	W/R	[307]	1Fh
Reserved*		1	-	[306]	-
Number of received sectors	NUMBER_OF_RECEIVED_SECTORS	4	R	[305:302]	0h

¹ BKOPS supported.

² Large Unit size 8MB.

Vendor proprietary health report	VENDOR_PROPRIETARY_HEALTH_REPORT	1	R	[301:270]	0h
Device life time estimation type B	DEVICE_LIFE_TIME_EST_TYP_B	1	R	[269]	0h
Device life time estimation type A	DEVICE_LIFE_TIME_EST_TYP_A	1	R	[268]	-
Pre EOL information	PRE_EOL_INFO	1	R	[267]	1h
Optimal read size	OPTIMAL_READ_SIZE	1	R	[266]	0h
Optimal write size	OPTIMAL_WRITE_SIZE	1	R	[265]	20h
Optimal trim unit size	OPTIMAL_TRIM_UNIT_SIZE	1	R	[264]	1h
Device version	DEVICE_VERSION	2	R	[263:262]	0h
Firmware version ³	FIRMWARE_VERSION	8	R	[261:254]	-
Power class for 200MHz ⁷ DDR at VCC=3.6V	PWR_CL_DDR_200_360	1	R	[253]	0h
Cache size	CACHE_SIZE	4	R	[252:249]	10000h
Generic CMD6 timeout ⁴	GENERIC_CMD6_TIME	1	R	[248]	Ah
Power-off notification(long) timeout ⁵	POWER_OFF_LONG_TIME	1	R	[247]	3Ch
Background operations status ⁶	BKOPS_STATUS	1	R	[246]	0h
Number of correctly programmed sectors	CORRECTLY_PRG_SECTORS_NUM	4	R	[245:242]	-
First Initialization time after partitioning ⁷	INI_TIMEOUT_AP	1	R	[241]	1Eh
Cache Flushing Policy	CACHE_FLUSH_POLICY	1	R	[240]	0h
Power class for 52Mhz, DDR at 3.6V ⁸	PWR_CL_DDR_52_360	1	R	[239]	0h

Name	Field	Size	Type	Slice[bytes]	Value
------	-------	------	------	--------------	-------

³ FW Patch Ver.

⁴ Generic CMD6 timeout 100ms.

⁵ Power off notification(long) timeout 600ms.

⁶ No operations required.

⁷ Initial time out 3s.

⁸ RMS 100 mA, peak 200 mA.

Power class for 52Mhz, DDR at 1.95V ⁹	PWR_CL_DDR_52_195	1	R	[238]	0h
Power class for 200Mhz at VCCQ=1.95V, VCC=3.6V	PWR_CL_200_195	1	R	[237]	0h
Power class for 200Mhz at VCCQ=1.3V, VCC=3.6V	PWR_CL_200_360	1	R	[236]	0h
Minimum write performance for 8bit at 52MHz in DDR mode ¹⁰	MIN_PERF_DDR_W_8_52	1	R	[235]	0h
Minimum read performance for 8bit at 52MHz in DDR mode ¹¹	MIN_PERF_DDR_R_8_52	1	R	[234]	0h
Reserved*		1	-	[233]	-
TRIM Multiplier ¹²	TRIM_MULT	1	R	[232]	5h
Secure feature support ¹³	SEC_FEATURE_SUPPORT	1	R	[231]	55h
Secure Erase Multiplier ¹⁴	SEC_ERASE_MULT	1	R	[230]	1Bh
Secure TRIM Multiplier ¹⁵	SEC_TRIM_MULT	1	R	[229]	11h
Boot Information ¹⁶	BOOT_INFO	1	R	[228]	7h
Reserved*		1	-	[227]	-
Boot partition size ¹⁷	BOOT_SIZE_MULTI	1	R	[226]	20h
Access size ¹⁸	ACC_SIZE	1	R	[225]	6h
High-capacity Erase unit size ¹⁹	HC_ERASE_GROUP_SIZE	1	R	[224]	1h
High-capacity Erase time out ²⁰	ERASE_TIMEOU_MULT	1	R	[223]	5h
Reliable write sector count ²¹	REL_WR_SEC_C	1	R	[222]	1h

⁹ RMS 65 mA, peak 130 mA.

¹⁰ For cards not reaching the 4.8MB/s value. Only support SDR.

¹¹ For cards not reaching the 4.8MB/s value.

¹² Trim time out 1.5s.

¹³ a) Support the secure and insecure trim operations.

b) Support the automatic secure purge operation on retired defective portions of the array.

c) Secure purge operations are supported.

d) Support the sanitize operation. ¹⁴ secure erase time out 40.5s.

¹⁵ secure trim time out 25.5s. ¹⁶ a)

Support high speed timing boot.

- b) Support dual data rate during boot.
- c) Support alternative boot method. ¹⁷ Boot partition 4096KB.
 - ¹⁸ Super page 16KB.
 - ¹⁹ High-capacity erase group size 512KB.
 - ²⁰ High-capacity erase time out 1.5s. ²¹ 1 sector.

Longsys Confidential For SZLCSC

Name	Field	Size	Type	Slice[bytes]	Value
High-capacity write protect group size ²²	HC_WP_GRP_SIZE	1	R	[221]	8h
Sleep current (VCC) ²³	S_C_VCC	1	R	[220]	7h
Sleep current [VCCQ] ²⁴	S_C_VCCQ	1	R	[219]	7h
Production state awareness timeout ²⁵	PRODUCTION_STATE_AWARENESS_TIMEOUT	1	R	[218]	0h
Sleep/Awake time out ²⁶	S_A_TIMEOUT	1	R	[217]	16h
Sleep Notification Time out ²⁷	SLEEP_NOTIFICATION_TIME	1	R	[216]	10h
Sector count ²⁸	SEC_COUNT	4	R	[215:212]	-
Secure Write Protection Mode	SECURE_WP_INFO	1		[211]	1h
Minimum Write Performance for 8bit @52MHz	MIN_PERF_W_8_52	1	R	[210]	0h
Minimum Read Performance for 8bit @52MHz	MIN_PERF_R_8_52	1	R	[209]	0h
Minimum Write Performance for 4bit @52MHz or 8bit @26MHz	MIN_PERF_W_8_26_4_52	1	R	[208]	0h
Minimum Read Performance for 4bit @52MHz or 8bit @26MHz	MIN_PERF_R_8_26_4_52	1	R	[207]	0h
Minimum Write Performance for 4bit @26MHz	MIN_PERF_W_4_26	1	R	[206]	0h
Minimum Read Performance for 4bit @26MHz	MIN_PERF_R_4_26	1	R	[205]	0h
Reserved*		1	-	[204]	-
Power Class for 26MHz @3.6V ²⁹	PWR_CL_26_360	1	R	[203]	0h
Power Class for 52MHz @3.6V ³⁰	PWR_CL_52_360	1	R	[202]	0h

High-capacity wp group size 4096KB.
 RMS 128µA.
 RMS 128µA.
 Not defined.
 Sleep/Awake timeout 419.43ms.
 Sleep Notification Time out 655.36ms.
 Depend on density.
 RMS 100 mA, peak 200 mA.
 RMS 100 mA, peak 200 mA.

Name	Field	Size	Type	Slice[bytes]	Value
Power Class for 26MHz @1.95V ³¹	PWR_CL_26_195	1	R	[201]	0h
Power Class for 52MHz @1.95V ³²	PWR_CL_52_195	1	R	[200]	0h
Partition switching timing ³³	PARTITION_SWITCH_TIME	1	R	[199]	Ah
Out-of-interrupt busy timing ³⁴	OUT_OF_INTERRUPT_TIME	1	R	[198]	5h
I/O Driver Strength	DRIVER_STRENGTH	1	R	[197]	1Fh
Card Type ³⁵	CARD_TYPE	1	R	[196]	57h
Reserved*		1	-	[195]	-
CSD Structure Version ³⁶	CSD_STRUCTURE	1	R	[194]	2h
Reserved*		1	-	[193]	-
Extended CSD Revision ³⁷	EXT_CSD_REV	1	R	[192]	8h
Command Set	CMD_SET	1	R/W/E_P	[191]	0h
Reserved*		1	-	[190]	-
Command set revision	CMD_SET_REV	1	R	[189]	0h
Reserved*		1	-	[188]	-
Power class	POWER_CLASS	1	R/W/E_P	[187]	Bh
Reserved*		1	-	[186]	-
High Speed Interface Timing	HS_TIMING	1	R/W/E_P	[185]	3h
Strobe Support	STROBE_SUPPORT	1	R	[184]	1h

Bus Width Mode	BUS_WIDTH	1	W/E_P	[183]	6h
Reserved*		1	-	[182]	-
Erased memory range	ERASE_MEM_CONT	1	R	[181]	0h
Reserved*		1	-	[180]	-
Partition Configuration	PARTITION_CONFIG	1	R/W/E, R/W/E_P	[179]	0h

- ⌚ RMS 65 mA, peak 130 mA.
- ⌚ RMS 65 mA, peak 130 mA.
- ⌚ Partition switch time out 100ms.
- ⌚ PI time out 50ms.
- ⌚ S400 DDR eMMC@200Mhz-1.8V I/O.
- ⌚ SD version No. 1.2.
- ⌚ Revision 1.8 (for MMC v5.1).

Name	Field	Size	Type	Slice[bytes]	Value
Boot config protection	BOOT_CONFIG_PROT	1	R/W, R/W/C_P	[178]	0h
Boot bus width1	BOOT_BUS_WIDTH	1	R/W/E	[177]	0h
Reserved*		1	-	[176]	-
High-density erase group definition	ERASE_GROUP_DEF	1	R/W/E_P	[175]	0h
Boot write protection status registers	BOOT_WP_STATUS	1	R	[174]	0h
Boot area write protect register	BOOT_WP	1	R/W, R/W/C_P	[173]	0h
Reserved*		1	-	[172]	-
User area write protect register	USER_WP	1	R/W, R/W/C_P, R/W/E_P	[171]	0h
Reserved*		1	-	[170]	-
FW Configuration	FW_CONFIG	1	R/W	[169]	0h
RPMB Size ⁹	RPMB_SIZE_MULT	1	R	[168]	20h
Write reliability setting register	WR_REL_SET	1	R/W	[167]	1Fh
Write reliability parameter register ¹⁰	WR_REL_PARAM	1	R	[166]	15h
Start Sanitize operation	SANITIZE_START	1	W/E_P	[165]	0h
Manually start background operations	BKOPS_START	1	W/E_P	[164]	0h
Enable background operations handshake	BKOPS_EN	1	R/W	[163]	0h
H/W reset function	RST_n_FUNCTION	1	R/W	[162]	0h
HPI management	HPI_MGMT	1	R/W/E_P	[161]	0h

⁹ RPMB size is 4MB.

¹⁰ Support the enhanced definition of reliable write.

Partitioning support ¹¹	PARTITIONING_SUPPORT	1	R	[160]	7h
Max Enhanced Area Size	MAX_ENH_SIZE_MULT	3	R	[159:157]	-
Partitions attribute	PARTITIONS_ATTRIBUTE	1	R/W	[156]	0h

Name	Field	Size	Type	Slice[bytes]	Value
Partitions setting	PARTITIONS_SETTING_COMPLETED	1	R/W	[155]	0h
General Purpose Partition Size	GP_SIZE_MULT	12	R/W	[154:143]	0h
Enhanced User Data Area Size	ENH_SIZE_MULT	3	R/W	[142:140]	0h
Enhanced User Data Start Address	ENH_START_ADDR	4	R/W	[139:136]	0h
Reserved*		1	-	[135]	-
Secure Bad Block Management Mode	SEC_BAD_BLK_MGMNT	1	R/W	[134]	0h
Production state awareness	PRODUCTION_STATE_AWARENESS	1	R/W/E	[133]	0h
Package Case Temperature is controlled	TCASE_SUPPORT	1	W/E_P	[132]	0h
Periodic Wake-up	PERIODIC_WAKEUP	1	R/W/E	[131]	0h
Program CID/CSD in DDR mode support	PROGRAM_CID_CSD_DDR_SUPPORT	1	R	[130]	1h
Reserved*		2	-	[129:128]	-
Vendor specific field	VENDOR_SPECIFIC_FIELD	64	<vendor specific>	[127:64]	0h
Native sector size	NATIVE_SECTOR_SIZE	1	R	[63]	0h
Sector size emulation	USE_NATIVE_SECTOR	1	R/W	[62]	0h
Sector size	DATA_SECTOR_SIZE	1	R	[61]	0h

¹¹ a) Enhanced technological features in partitions and user data area.

b) Device supports partitioning features

c) Device can have extended partition attribute.

1st initialization after disabling sector size emulation	INI_TIMEOUT_EMU	1	R	[60]	0h
Class 6 commands control	CLASS_6_CTRL	1	R/W/E_P	[59]	0h
Number of addressed groups to be Released	DYNCAP_NEEDED	1	R	[58]	0h
Exception events control	EXCEPTION_EVENTS_CTRL	2	R/W/E_P	[57:56]	0h
Exception events status	EXCEPTION_EVENTS_STATUS	2	R	[55:54]	0h
Extended Partitions Attribute	EXT_PARTITIONS_ATTRIBUTE	2	R/W	[53:52]	0h
Context configuration	CONTEXT_CONF	15	R/W/E_P	[51:37]	0h
Packed command status	PACKED_COMMAND_STATUS	1	R	[36]	0h
Packed command failure index	PACKED_FAILURE_INDEX	1	R	[35]	0h
Power Off Notification	POWER_OFF_NOTIFICATION	1	R/W/E_P	[34]	0h
Name	Field	Size	Type	Slice[bytes]	Value
Control to turn the Cache ON/OFF	ON/OFF CACHE_CTRL	1	R/W/E_P	[33]	0h
Flushing of the cache	FLUSH_CACHE	1	W/E_P	[32]	0h
Control to turn the Barrier ON/OFF	ON/OFF BARRIER_CTRL	1	R/W	[31]	0h
Mode config	MODE_CONFIG	1	R/W/E_P	[30]	0h
Mode operation codes	MODE_OPERATION_CODES	1	W/E_P	[29]	0h
	Reserved*	2	-	[28:27]	-
FFU status	FFU_STATUS	1	R	[26]	0h
Pre loading data size	PRE_LOADING_DATA_SIZE	4	R/W/E_P	[25:22]	0h
Max pre loading data size	MAX_PRE_LOADING_DATA_SIZE	4	R	[21:18]	-
Product state awareness enablement	PRODUCT_STATE_AWARENESS_ENABLEMENT	1	R/W/E, R	[17]	0h
Secure Removal Type	SECURE_REMOVAL_TYPE	1	R/W, R	[16]	9h

Command Queue Mode Enable	CMDQ_MODE_EN	1	R/W/E_P	[15]	0h
Reserved*		15	-	[14:0]	-

Note:

1 Type:

R: Read only

W: One time programmable and NOT readable.

R/W: One time programmable and readable.

R/W/E: Multiple writable with value kept after power failure, H/W reset assertion and any CMD0 reset and readable. R/W/C_P: Writable after value cleared by power failure and HW/ rest assertion (the value not cleared by CMD0 reset) and readable.

R/W/E_P: Multiple writable with value reset after power failure, H/W reset assertion and any CMD0 reset and readable.

2 Reserved*: Reserved bits should be read as 0.

7.4 OCR Register

The 32-bit operation conditions register stores the VCCQ voltage profile of the eMMC. In addition, this register includes a status information bit. This status bit is set if the eMMC power up procedure has been finished. The OCR register shall be implemented by eMMC.

Table 15. OCR register

OCR bit	VCCQ voltage window	eMMC
[6:0]	Reserved	000 0000b
[7]	1.7–1.95	1b
[14:8]	2.0–2.6	000 0000b
[23:15]	2.7–3.6	1 1111 1111b
[28:24]	Reserved	000 0000b
[30:29]	Access Mode	00b (byte mode)/10b (sector mode)
[31]	power up status bit (busy)*	

Note:

This bit is set to LOW if the eMMC has not finished the power up routine. The supported voltage range is coded as shown in table.

7.5 Field firmware update (FFU)

To download a new firmware, the controller requires instruction sequence following JEDEC standard.

Longsys eMMC only supports Manual mode (MODE_OPERATION_CODES is not supported). For more details, refer to the App note.

7.5.1 Longsys eMMC (FEMDRWxxxG-88A19) Field F/W update flow - CMD sequence

Table 16. FFU Command Sequence

Operation	CMD	Remark
Set block length 512B	CMD16, arg: 0x00000200	
Enter FFU mode	CMD6, arg: 0x031E0100	
Send FW to device (Download)	CMD25, arg: 0x00000000	Sending CMD25 is followed by sending FW data, the whole data should be sent by one CMD25
CMD12: Stop	CMD12, arg: 0x00000000	
CMD6: Exit FFU mode	CMD6, arg: 0x031E0000	
HW Reset/Power cycle		CMD0 Reset is not support
Re-Init to trans state	CMD0, CMD1 ...	
Check if FFU is succeeded	CMD8, arg: 0x00000000	Check EXT_CSD [26]: FFU_SUCCESS If FFU_SUCCESS is 0, FFU is succeeded, otherwise FFU is failed. Do not verify data with CMD17/CMD18 while FFU mode.

7.5.2 SUPPORTED_MODE [493] (Read Only)

BIT [0]: '0' FFU is not supported by the device.

'1' FFU is supported by the device.

BIT [1]: '0' Vendor specific mode (VSM) is not supported by the device.

'1' Vendor specific mode is supported by the device.

Table 17. FFU Supported Mode Register

Bit	Field	Supportability
BIT [7:2]	Reserved	-
BIT [1]	VSM	Not support
BIT [0]	FFU	Support

7.5.3 FFU_FEATURE [492] (Read Only)

BIT [0]: '0' Device does not support MODE_OPERATION_CODES field (Manual mode).

'1' Device supports MODE_OPERATION_CODES field (Auto mode).

Table 18. FFU Feature Register

Bit	Field	Supportability
BIT [7:1]	Reserved	-
BIT [0]	SUPPORTED_MODE_OPERATION_CODES	Not support

7.5.4 FFU_ARG [490-487] (Read Only)

Using this field, the device reports to the host which value the host should set as an argument for read and write commands in FFU mode.

7.5.5 FW_CONFIG[169] (R/W)

BIT [0]: '0' FW updates enabled.

'1' FW update disabled permanently

Table 19. FFU FW Config Register

Bit	Field	Supportability
BIT [7:1]	Reserved	-
BIT [0]	Update disable	FW updates enabled (0x0)

7.5.6 FFU_STATUS [26] (R/W/E_P)

Using this field, the device reports to the host the state of FFU process **Table 20. FFU**

Status Register

Value	Description
0x13 ~ 0xFF	Reserved
0x12	Error in downloading Firmware
0x11	Firmware install error
0x10	General error
0x01 ~ 0x0F	Reserved
0x00	Success

7.5.7 OPERATION_CODES_TIMEOUT[491](Read Only)

Maximum timeout for the SWITCH command when setting a value to the MODE_OPERATION_CODES field. The register is set to '0', because the controller doesn't support MODE_OPERATION_CODES. **Table 21. FFU Operation Codes Timeout Register**

Value	Description	Timeout value
0x01 ~ 0x17	MODE_OPERATION_CODES_TIMEOUT = 100us x 2OPERATION_CODES_TIMEOUT	(Not defined)
0x18 ~ 0xFF	Reserved	-

7.5.8 MODE_OPERATION_CODES[29] (W/E_P)

The host sets the operation to be performed at the selected mode, in case MODE_CONFIGS is set to FFU_MODE, MODE_OPERATION_CODES could have the following values:

Table 22. FFU Mode Operation Codes Register

Value	Description
0x01	FFU_INSTALL
0x02	FFU_ABORT
0x00, others	Reserved

7.6 S.M.A.R.T. Health Report

S.M.A.R.T. is a monitoring system that detects and reports on various indicators of eMMC reliability (Including original bad blocks, increased bad blocks, power-up number, power-loss counts and etc.), with the intent of enabling the anticipation of hardware failures. We may be able to use recorded S.M.A.R.T. data to discover where the faults lie, ensure how to solve the problems and prevent them from recurring in future eMMC designs (For details, please refer to app note).

(End of Document)

Longsys Confidential For SZLCSC

X-ON Electronics

Largest Supplier of Electrical and Electronic Components

Click to view similar products for [Flash category](#):

Click to view products by [FORESEE manufacturer](#):

Other Similar products are found below :

[615309A](#) [S29GL064S70BHI030](#) [S29GL064S70BHI040](#) [W25Q64FWZPIGT](#) [BH25D10CSUIG](#) [BH25D40ASUIG](#) [BH25Q32BSWIG](#)
[BH25D16ASUIG](#) [P25Q80UF-D8H-IR](#) [FS35ND01G-S1Y2QWFI000](#) [FS35ND02G-S3Y2QWFI000](#) [FM25M64C-1AIB4R](#) [DS35M1GA-IB](#)
[MKDV2GIL-AS](#) [W25Q256JVFIQT](#) [MKDV1GIL-AS](#) [S25FL127SABBHIC00](#) [S25FL128SDSBHI210](#) [S25FL256SAGBHIC00](#)
[S25FL256SDSBHI210](#) [S25FS128SDSNFI101](#) [S25FS256SDSBHI200](#) [S29GL064S70DHI010](#) [S29GL064S70FHI010](#) [S29GL064S80FHIV10](#)
[S29GL064S80TFIV10](#) [SST39VF020-70-4I-WHE](#) [SST39VF010-70-4C-NHE](#) [SST39SF010A-70-4I-WHE](#) [SST39LF200A-55-4C-EKE](#)
[SST38VF6401-90-5I-B3KE](#) [S25FL512SAGBHI210](#) [SST49LF160C-33-4C-NHE](#) [SST49LF080A-33-4C-NHE](#) [SST49LF008A-33-4C-WHE](#)
[SST39WF1601-70-4C-B3KE](#) [SST39VF800A-70-4I-B3KE](#) [SST39VF800A-70-4C-EKE](#) [SST39VF3201B-70-4I-B3KE](#) [SST39VF200A-70-4C-](#)
[EKE](#) [SST39VF1601-70-4C-EKE](#) [SST39VF040-70-4C-WHE](#) [SST25WF040BT-40I/NP](#) [SST25VF080B-50-4C-QAF](#) [SST25VF040B-50-4I-](#)
[SAF](#) [S25FL132K0XBHI020](#) [S25FL256SAGNFI011](#) [S25FS128SAGBHI200](#) [S25FS128SAGNFI101](#) [S25FS256SAGBHI200](#)