

Specification

100Gb/s QSFP28 to 4x SFP28 Fanout Optical Transceiver Module



Ordering Information

TQS-214H8-X83xx

Length

Part Number	Description
TQS-214H8-X8301	QSFP28 to SFP28 Breakout Active Optical Cable, 1m
TQS-214H8-X8303	QSFP28 to SFP28 Breakout Active Optical Cable, 3m
TQS-214H8-X8305	QSFP28 to SFP28 Breakout Active Optical Cable, 5m
TQS-214H8-X8307	QSFP28 to SFP28 Breakout Active Optical Cable, 7m
TQS-214H8-X8310	QSFP28 to SFP28 Breakout Active Optical Cable, 10m
TQS-214H8-X8320	QSFP28 to SFP28 Breakout Active Optical Cable, 20m
TQS-214H8-X8330	QSFP28 to SFP28 Breakout Active Optical Cable, 30m

Model Name	Voltage	Device type	Interface	Temperature	Latch Color	
TQS-214H8-X83xx	3.3V	VCSEL	CML/CML	0 ~+70°C	SFP28	Black
					QSFP28	Beige

Features

- 4 independent full-duplex channels
- Up to 28Gb/s data rate per channel
- QSFP28 and SFP28 MSA compliant
- Up to 100m OM4 MMF transmission
- Single +3.3V power supply
- Operating case temperature: 0 to 70°C
- Maximum power consumption of 2W for QSFP28 terminal and 1.0W for each SFP28 terminal
- RoHS compliant

Applications

- 100GBASE Ethernet Links
- Infiniband EDR interconnects

Pin Assignment and Pin Description

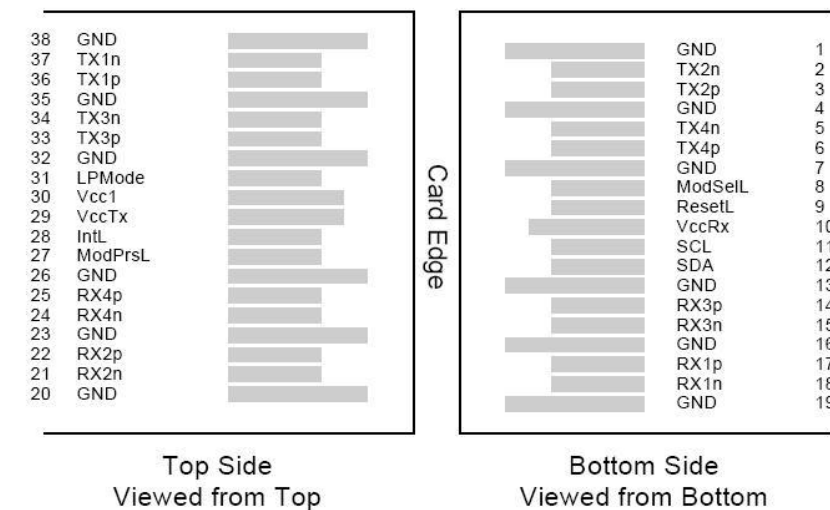

Figure 1. MSA compliant QSFP28 Connector

Pin Definitions (QSFP28)

PIN	Logic	Symbol	Name/Description	Note
1		GND	Ground	1
2	CML-I	Tx2n	Transmitter Inverted Data Input	
3	CML-I	Tx2p	Transmitter Non-Inverted Data output	
4		GND	Ground	1
5	CML-I	Tx4n	Transmitter Inverted Data Input	
6	CML-I	Tx4p	Transmitter Non-Inverted Data output	
7		GND	Ground	1
8	LVTLL-I	ModSelL	Module Select	
9	LVTLL-I	ResetL	Module Reset	
10		VccRx	+3.3V Power Supply Receiver	2
11	LVC MOS-I/O	SCL	2-Wire Serial Interface Clock	
12	LVC MOS-I/O	SDA	2-Wire Serial Interface Data	
13		GND	Ground	
14	CML-O	Rx3p	Receiver Non-Inverted Data Output	
15	CML-O	Rx3n	Receiver Inverted Data Output	
16		GND	Ground	1
17	CML-O	Rx1p	Receiver Non-Inverted Data Output	
18	CML-O	Rx1n	Receiver Inverted Data Output	
19		GND	Ground	1
20		GND	Ground	1
21	CML-O	Rx2n	Receiver Inverted Data Output	
22	CML-O	Rx2p	Receiver Non-Inverted Data Output	
23		GND	Ground	1
24	CML-O	Rx4n	Receiver Inverted Data Output	1
25	CML-O	Rx4p	Receiver Non-Inverted Data Output	
26		GND	Ground	1
27	LVTTL-O	ModPrsL	Module Present	
28	LVTTL-O	IntL	Interrupt	
29		VccTx	+3.3 V Power Supply transmitter	2
30		Vcc1	+3.3 V Power Supply	2
31	LVTTL-I	LPMODE	Low Power Mode	
32		GND	Ground	1
33	CML-I	Tx3p	Transmitter Non-Inverted Data Input	
34	CML-I	Tx3n	Transmitter Inverted Data Output	

35		GND	Ground	1
36	CML-I	Tx1p	Transmitter Non-Inverted Data Input	
37	CML-I	Tx1n	Transmitter Inverted Data Output	
38		GND	Ground	1

Notes:

1. GND is the symbol for signal and supply (power) common for the QSFP28 module. All are common within the module and all module voltages are referenced to this potential unless otherwise noted. Connect these directly to the host board signal common ground plane.
2. VccRx, Vcc1 and VccTx are the receiving and transmission power suppliers and shall be applied concurrently. Recommended host board power supply filtering is shown in Figure 3 below. Vcc Rx, Vcc1 and Vcc Tx may be internally connected within the QSFP28 transceiver module in any combination. The connector pins are each rated for a maximum current of 1000mA.

SFP28 Terminals

The SFP28 modules are hot-pluggable. Hot pluggable refers to plugging in or unplugging a module while the host board is powered. The SFP28 host connector is a 0.8 mm pitch 20 position right angle improved connector specified by SFF-8083, or stacked connector with equivalent with equivalent electrical performance. Host PCB contact assignment is shown in Figure 2 and contact definitions are given in the PIN description table. SFP28 module contacts mates with the host in the order of ground, power, followed by signal as illustrated by Figure 3 and the contact sequence order listed in the PIN description table.

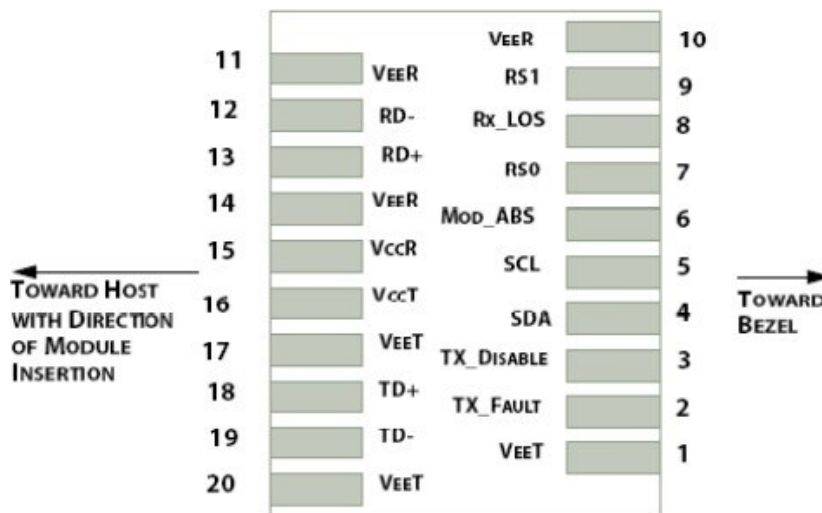

Figure 2. SFP28 Module Interface to Host

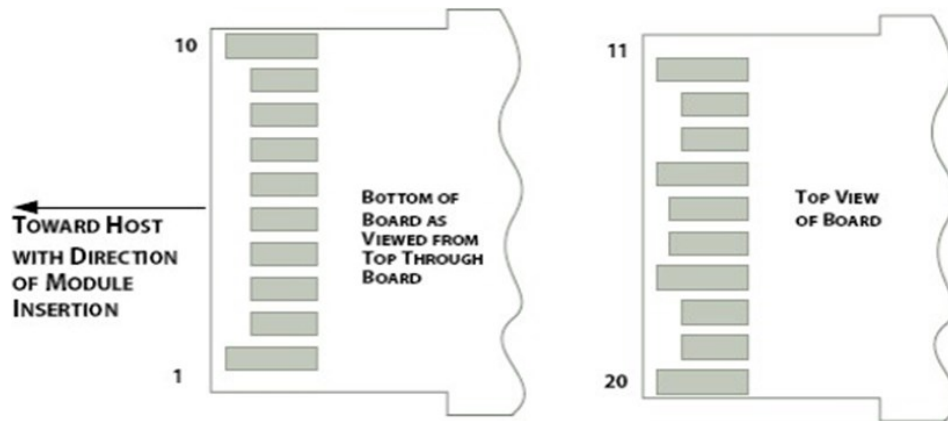

Figure 3. SFP28 Module Contact Assignment

SFP28

PIN	Logic	Symbol	Name / Description	Notes
1		VeeT	Module Transmitter Ground	1
2	LVTTL-O	TX_Fault	Module Transmitter Fault	
3	LVTTL-I	TX_Dis	Transmitter Disable; Turns off transmitter laser output	
4	LVTTL-I/O	SDA	2-Wire Serial Interface Data Line	2
5	LVTTL-I	SCL	2-Wire Serial Interface Clock	2
6		MOD_DEFO	Module Definition, Grounded in the module	
7	LVTTL-I	RS0	Receiver Rate Select	
8	LVTTL-O	RX_LOS	Receiver Loss of Signal Indication Active LOW	
9	LVTTL-I	RS1	Transmitter Rate Select (not used)	
10		VeeR	Module Receiver Ground	1
11		VeeR	Module Receiver Ground	1
12	CML-O	RD-	Receiver Inverted Data Output	
13	CML-O	RD+	Receiver Data Output	
14		VeeR	Module Receiver Ground	1
15		VccR	Module Receiver 3.3 V Supply	
16		VccT	Module Receiver 3.3 V Supply	
17		VeeT	Module Transmitter Ground	1
18	CML-I	TD+	Transmitter Non-Inverted Data Input	
19	CML-I	TD-	Transmitter Inverted Data Input	
20		VeeT	Module Transmitter Ground	1

Notes:

1. Module ground pins GND are isolated from the module case.
2. Shall be pulled up with 4.7K-10Kohms to a voltage between 3.15V and 3.45V on the host board.

Recommended Power Supply Filter

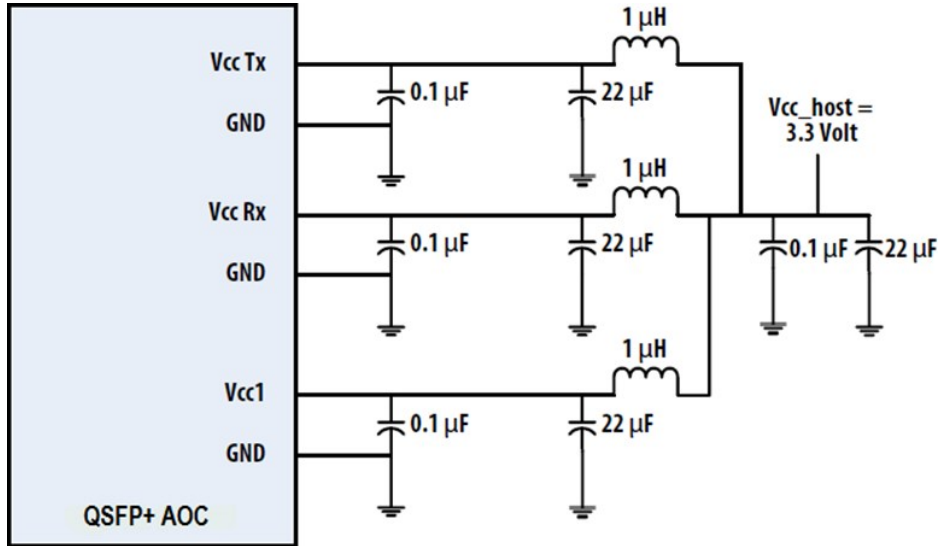

Figure 4. Recommended Power Supply Filter for QSFP28 Terminal

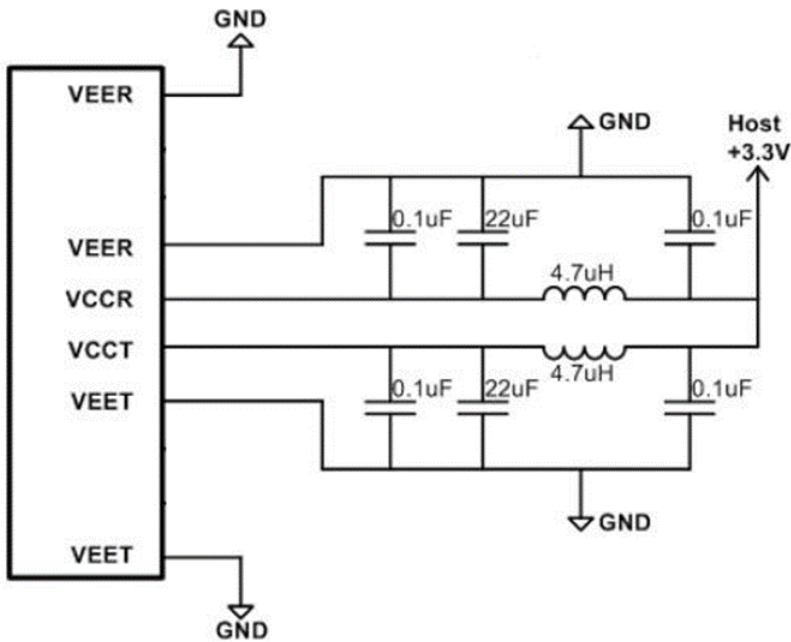

Figure 5. Recommended Power Supply Filter for SFP28 Terminals

Absolute Maximum Ratings

It has to be noted that the operation in excess of any individual absolute maximum ratings might cause permanent damage to this module.

Parameter	Symbol	Min	Max	Unit	Notes
Storage Temperature	T_s	-40	85	°C	
Operating Case Temperature	T_{OP}	0	70	°C	
Power Supply Voltage	V_{CC}	-0.5	3.6	V	
Relative Humidity (non-condensation)	RH	0	85	%	

Recommended Operating Conditions and Power Supply Requirements

Parameter	Symbol	Min	Typ.	Max	Unit
Operating Case Temperature	T_{OP}	0		70	°C
Power Supply Voltage	V_{CC}	3.135	3.30	3.465	V
Data Rate, each Lane (QSFP28)			25.78125		Gb/s
Data Rate (each SFP28)			25.78125		Gb/s
Control Input Voltage High		2		V_{CC}	V
Control Input Voltage Low		0		0.8	V

Electrical Characteristics

The following electrical characteristics are defined over the Recommended Operating Environment unless otherwise specified.

(QSFP28 Terminal)

Parameter	Symbol	Min	Typ.	Max	Units	Notes
Power Consumption each Terminal				2	W	
Supply Current each Terminal	I _{cc}			600	mA	
Transceiver Power-on Initialization Time				2000	ms	1
Transmitter (each Lane)						
Overload Differential Voltage pk-pk	TP1a			900	mV	
Differential Termination Resistance Mismatch	TP1			10	%	
Differential Return Loss (SDD11)	TP1			See CEI- 28G-VSR Equation 13-19	dB	
Common Mode to Differential conversion and Differential to Common Mode conversion (SDC11, SCD11)	TP1			See CEI- 28G-VSR Equation 13-20	dB	
Receiver (each Lane)						
Differential Voltage, pk-pk	TP4			900	mV	
Differential Termination Resistance Mismatch	TP4			10	%	
Differential Return Loss (SDD22)	TP4			See CEI- 28G-VSR Equation 13-19	dB	
Common Mode to Differential conversion and Differential to Common Mode conversion (SDC22, SCD22)	TP4			See CEI- 28G-VSR Equation 13-21	dB	

Common Mode Return Loss (SCC22)	TP4			-2	dB	2
Transition Time, 20 to 80%	TP4	9.5			Ps	
Eye Width at 10^{-15} probability	TP4	0.57			UI	
Eye Height at 10^{-15} probability	TP4	228			mV	

(SFP28 Terminals)

Parameter	Symbol	Min	Typ.	Max	Units	Notes
Power Consumption				1000	mW	
Supply Current, each SFP28	Icc			300	mA	
Transmitter						
Overload Differential Voltage pk-pk	TP1a			900	mV	
Differential Termination Resistance Mismatch	TP1			10	%	
Differential Return Loss (SDD11)	TP1			See CEI-28G-VSR Equation 13-19	dB	
Common Mode to Differential conversion and Differential to Common Mode conversion (SDC11, SCD11)	TP1			See CEI-28G-VSR Equation 13-20	dB	
Receiver						
Differential Voltage, pk-pk	TP4			900	mV	
Differential Termination Resistance Mismatch	TP4			10	%	
Differential Return Loss (SDD22)	TP4			See CEI-28G-VSR Equation 13-19	dB	
Common Mode to Differential conversion and Differential to Common Mode conversion (SDC22, SCD22)	TP4			See CEI-28G-VSR Equation 13-21	dB	
Common Mode Return Loss (SCC22)	TP4			-2	dB	2

Transition Time, 20 to 80%	TP4	9.5			Ps	
Eye Width at 10^{-15} probability	TP4	0.57			UI	
Eye Height at 10^{-15} probability	TP4	228			mV	

Mechanical Dimensions (Unit: mm)

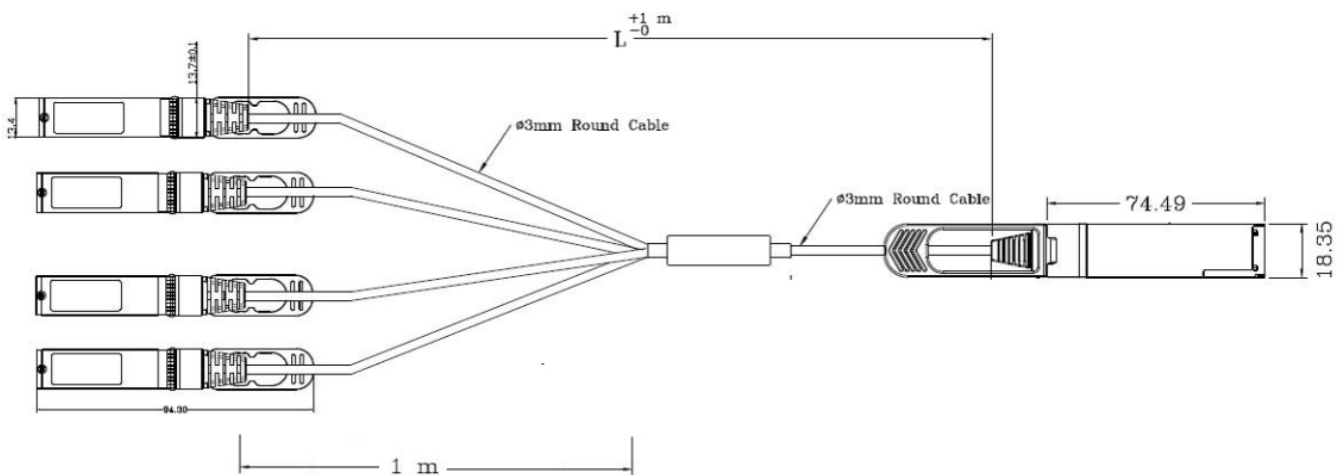

Figure 7. Mechanical Outline

ESD

Normal ESD precautions are required during the handling of this module. This transceiver is shipped in ESD protective packaging. It should be removed from the packaging and handled only in an ESD protected environment.

Laser Safety

This is a Class 1 Laser Product according to IEC / EN 60825-1: 2014 (Third Edition). This product complies with 21 CFR 1040.10 and 1040.11 except for deviations pursuant to Laser Notice No. 50, dated (June 24, 2007).

Caution: Use of controls or adjustments or performance of procedures other than those specified herein may result in hazardous radiation exposure.



Contact Information

Formerica OptoElectronics Inc.

5F-11, No.38, Taiyuan St., Zhubei City,
Hsinchu County 30265, Taiwan

Tel: +886-3-5600286

Fax: +886-3-5600239

San Diego, CA

Tel: 1-949-466-8069

inquiry@formericaoe.com

www.formericaoe.com

Revision History

Date	Version	Description
02/27/2019	1.0	Initial release
4/30/2020	1.1	<ol style="list-style-type: none">1. Add ordering information table with PN information per length2. Remove "category" column in in ordering information table3. Correct the typo of reach distance description in feature section

X-ON Electronics

Largest Supplier of Electrical and Electronic Components

Click to view similar products for [Fibre Optic Transmitters, Receivers, Transceivers](#) *category:*

Click to view products by [Formerica Optoelectronics](#) *manufacturer:*

Other Similar products are found below :

[STV.2413-574-00262](#) [TRPRG1VA1C000E2G](#) [TOTX1350\(V,F\)](#) [FTLX3813M349](#) [SCN-1428SC](#) [LTK-ST11MB](#) [HFD8003-002/XBA](#)
[HFD3020-500-ABA](#) [FTLF1429P3BCVA](#) [S6846](#) [SCN-2638SC](#) [FTLC9555FEPM](#) [TQS-QG4H9-J83](#) [SCN-1570SC](#) [SCN-1601SC](#) [SCN-](#)
[1338SC](#) [SFPPT-SR3-01](#) [HFD8003-500-XBA](#) [SCN-1383SC](#) [2333569-1](#) [LNK-ST11HB-R6](#) [FTL4C1QL3L](#) [FTL4C1QE3L](#) [FTL4C1QL3C](#)
[SPTSHP3PMCDF](#) [SPTSBP4LLCDF](#) [SPTMBP1PMCDF](#) [SPTSHP2PMCDF](#) [SF-NLNAMB0001](#) [SPTSLLP2SLCDF](#) [SPTSQP4LLCDF](#)
[1019682](#) [1019683](#) [1019705](#) [HFBR-1415Z](#) [AFBR-5803ATQZ](#) [AFBR-5803ATZ](#) [PLR135/T9](#) [TGW-Q14BB-FCQ](#) [TQS-Q1LH8-XCA03](#) [TQS-](#)
[Q1LH8-XCA05](#) [TQS-Q1LH8-XCA10](#) [TQS-Q1LH9-2CA](#) [HFBR-1414Z](#) [HFBR-1527Z](#) [HFBR-1528Z](#) [HFBR-2406Z](#) [HFBR-2505AZ](#) [HFBR-](#)
[2532Z](#) [HFBR-1532Z](#)