

Datasheet

# FS326

One Cell Lithium-ion/Polymer Battery Protection IC

FORTUNE,  
Properties,  
For Reference Only

**Fortune Semiconductor Corporation**

富晶電子股份有限公司  
28F, No. 27, Sec. 2, Zhongzheng E. Rd.,  
Danshui Dist, New Taipei City 251, Taiwan  
Tel. : 886-2-28094742  
Fax : 886-2-28094874  
www.ic-fortune.com

This manual contains new product information. **Fortune Semiconductor Corporation** reserves the rights to modify the product specification without further notice. No liability is assumed by Fortune Semiconductor Corporation as a result of the use of this product. No rights under any patent accompany the sale of the product.

### 1. General Description

FS326 is a series of lithium-ion and lithium-polymer rechargeable battery protection ICs with high accurate voltage detection and delay circuits.

These ICs are suitable for protection of single cell lithium-ion or lithium polymer battery packs from over charge, over discharge and over current.

### 2. Features

Low supply current	Normal
Operation : 3.0μ A typ. @VDD=3.9V	
Power-down mode : 0.1μ A max. @VDD=2.0V	
Overcharge detection voltage	{ VOCU }
4.2V~4.4V, Accuracy of ±25mV	
Overcharge release voltage	{ VOCR }
3.8V~4.2V, Accuracy of ±50mV	
Overdischarge detection voltage	{ VODL }
2.2V~2.9V, Accuracy of ±50*mV	
Overdischarge release voltage	{ VODR }
2.8V~3.2V, Accuracy of ±50*mV	
Over current detection voltage	{ VOI1 }
0.05V~0.2V, Accuracy of ±30mV	
Short circuit detection voltage	{ VOI2 }
Fixed at 1.35V	
Delay times are generated by an internal circuit. (External capacitors are unnecessary.)	
Charger detection voltage	-0.7V
Reset resistance for Over current protection	
>500k	
Wide supply voltage range	1.8 ~ 9.0V
Small package	SOT-23-6

### 3. Ordering Information

FS326 **x**  
 └── Serial code from C to H \*

\*: Refer to the product name list on next page.

FS326 **x-P (P stands for Pb-free)**  
 └── Serial code from C to H \*

\*: Refer to the product name list on next page.

### 4. Applications

Protection IC for One-Cell Lithium-Ion / Lithium-Polymer Battery Pack

5. Product Name List

Model	Package	Overcharge detection voltage [VOCU] (V)	Overcharge release voltage [VOCR] (V)	Overdischarge detection voltage [VODL] (V)	Overdischarge release voltage [VODR] (V)	Overcurrent detection voltage [VOI1] (mV)
	SOT-23-6					
FS326	C	4.325±0.025	4.075±0.05	2.50±0.08	2.90±0.08	150±30
	F	4.275±0.025	4.10±0.05	2.30±0.05	2.90±0.05	100±30
	G	4.280±0.025	4.175±0.05	2.90±0.08	3.00±0.08	150±30
	H	4.250±0.025	4.075±0.05	2.30±0.05	2.90±0.05	150±30

Overcharge, overdischarge and overcurrent detection voltages can be changed at the customer's request.

6. Pin Configuration

Pin No.	Symbol	Description
1	OD	FET gate connection pin for discharge control
2	CSI	Input pin for current sense, charger detect
3	OC	FET gate connection pin for charge control
4	DS	Test pin for reduce delay time
5	VDD	Positive power input pin
6	VSS	Negative power input pin

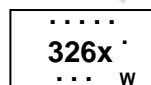
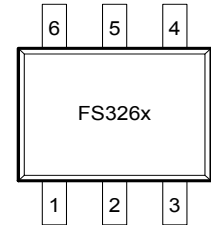

Top Point : Lot No.  
 Bottom Point : Year  
 w : week, A~Z & A ~ Z  
 A dot after marking : Pb Free

7. Functional Block Diagram

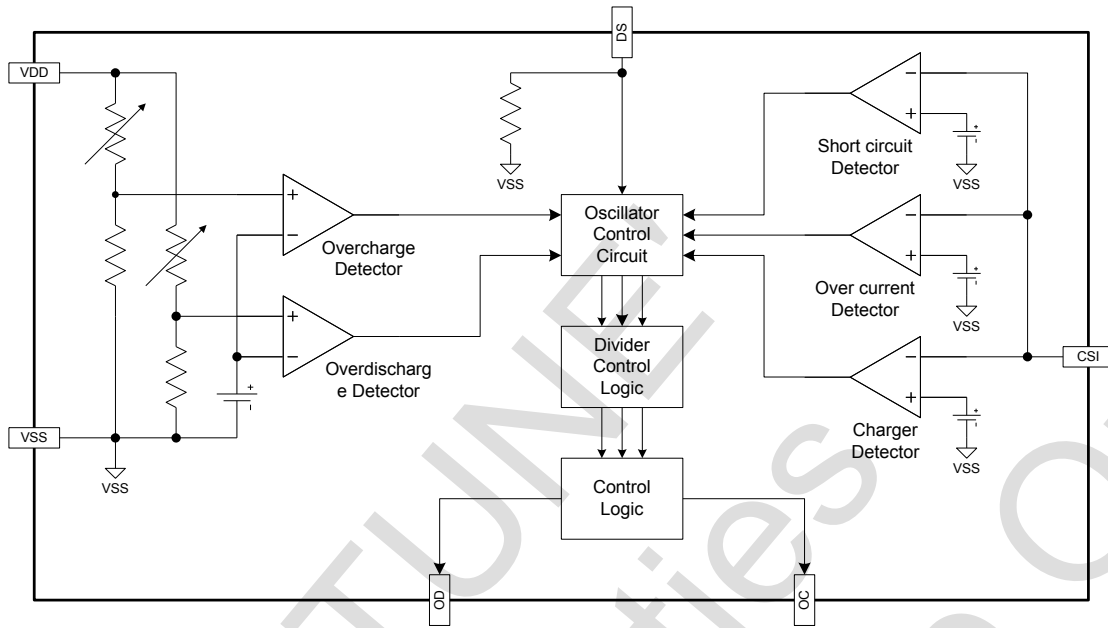

8. Typical Application Circuit

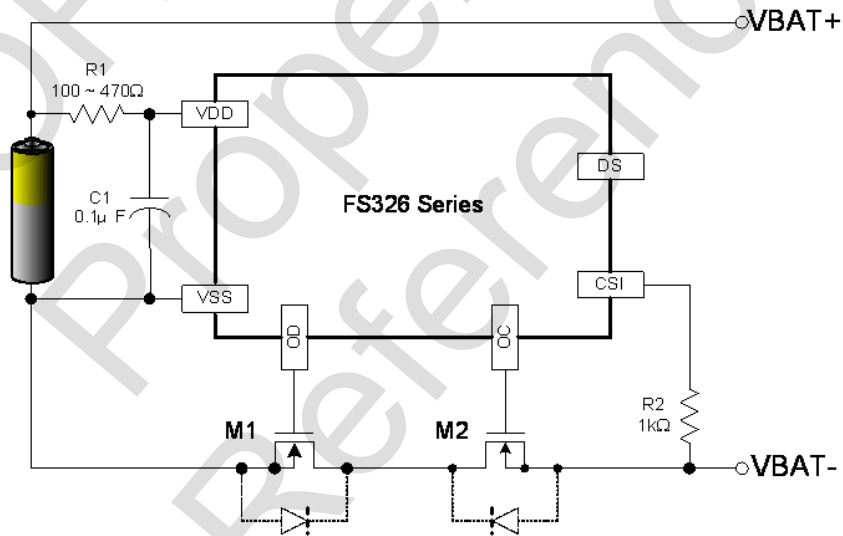

**9. Absolute Maximum Ratings**

(VSS=0V, Ta=25°C unless otherwise specified)

Item	Symbol	Rating	Unit
Input voltage between VDD and VSS *	VDD	VSS -0.3 to VSS +12	V
OC output pin voltage	VOC	VDD -24 to VDD +0.3	V
OD output pin voltage	VOD	VSS -0.3 to VDD +0.3	V
CSI input pin voltage	VCSI	VDD -24 to VDD +0.3	V
DS input pin voltage	VDS	VSS -0.3 to VDD +0.3	V
Operating Temperature Range	TOP	-40 to +85	°C
Storage Temperature Range	TST	-40 to +125	°C

Note: FS326 contains a circuit that will protect it from static discharge; but please take special care that no excessive static electricity or voltage which exceeds the limit of the protection circuit will be applied to it.

\* Pulse ( $\mu$  sec) noise exceeding the above input voltage (VSS+12V) may cause damage to the IC.

**10. Electrical Characteristics (except FS326G)**

(VSS=0V, DS=Floating, Ta=25°C unless otherwise specified)

PARAMETER	CONDITIONS	SYMBOL	Min	Typ	Max	UNIT
<b>CURRENT CONSUMPTION</b>						
Supply Current	VDD=3.9V	IDD		3.0	6.0	μ A
Power-Down Current	VDD=2.0V	IPD			0.1	μ A
<b>OPERATING VOLTAGE</b>						
Operating input voltage	VDD-VSS	VDS1	1.8		9.0	V
<b>DETECTION VOLTAGE</b>						
Overcharge detection voltage		VOCU	VOCU -0.025	VOCU	VOCU +0.025	V
Overcharge release voltage		VOCR	VOCR -0.050	VOCR	VOCR +0.050	V
Overdischarge detection voltage		VODL	VODL -0.080*	VODL	VODL +0.080*	V
Overdischarge release voltage		VODR	VODR -0.080*	VODR	VODR +0.080*	V
Over current detection voltage		VOI1	VOI1 -0.030	VOI1	VOI1 +0.030	V
Short circuit detection voltage	VDD=3.0V	VOI2	1.0	1.35	1.7	V
Reset resistance for Over current protection	VDD=3.6V	Rshort	400	500	600	kΩ
Charger detection voltage		VCH	-1.2	-0.7	-0.2	V
<b>DELAY TIME</b>						
Overcharge detection delay time	VDD=3.6V to 4.4V	TOC	0.7	1.3	1.9	s
Overdischarge detection delay time	VDD=3.6V to 2.0V	TOD	100	180	260	ms
Over current detection delay time	VDD=3.0V	TOI1	5	10	15	ms
Short circuit detection delay time	VDD=3.0V	TOI2	5	10	50	μ s
<b>OTHER</b>						
OC pin output "H" voltage	VDD=3.9V, loh=-50 μ A	Voh1	3.4	3.7		V
OC pin output "L" voltage	VDD=4.5V, CSI=0V	Vol1		0.1	0.5	V
OD pin output "H" voltage	VDD=3.9V, loh=-50 μ A	Voh2	3.4	3.7		V
OD pin output "L" voltage	VDD=2.0V, lol=50 μ A	Vol2		0.1	0.5	V

\*: For FS326F, the accuracy is ±0.05V.

Operating junction temperature range ----- -40°C to +125°C

Lead temperature (soldering, 10sec) ----- 260°C

\* Stresses beyond those listed under "absolute maximum ratings" may cause permanent damage to the device. These are stress ratings only, and function operation of the device at these or any other conditions beyond those indicated under "recommended operating conditions" is not implied. Exposure to absolute-maximum-rated conditions for extended periods may affect device reliability.

**Electrical Characteristics (FS326G only)**

(VSS=0V, DS=Floating, Ta=25°C unless otherwise specified)

PARAMETER	CONDITIONS	SYMBOL	Min	Typ	Max	UNIT
<b>CURRENT CONSUMPTION</b>						
Supply Current	VDD=3.9V	IDD		3.0	6.0	μA
Power-Down Current	VDD=2.0V	IPD			0.1	μA
<b>OPERATING VOLTAGE</b>						
Operating input voltage	VDD-VSS	VDS1	1.8		9.0	V
<b>DETECTION VOLTAGE</b>						
Overcharge detection voltage		VOCU	VOCU -0.025	VOCU	VOCU +0.025	V
Overcharge release voltage		VOCR	VOCR -0.050	VOCR	VOCR +0.050	V
Overdischarge detection voltage		VODL	VODL -0.080	VODL	VODL +0.080	V
Overdischarge release voltage		VODR	VODR -0.080	VODR	VODR +0.080	V
Over current detection voltage		VOI1	VOI1 -0.030	VOI1	VOI1 +0.030	V
Short circuit detection voltage	VDD=3.0V	VOI2	1.0	1.35	1.7	V
Reset resistance for Over current protection	VDD=3.6V	Rshort	400	500	600	k
Charger detection voltage		VCH	-1.2	-0.7	-0.2	V
<b>DELAY TIME</b>						
Overcharge detection delay time	VDD=3.6V to 4.4V	TOC		200	300	ms
Overdischarge detection delay time	VDD=3.6V to 2.0V	TOD		50	80	ms
Over current detection delay time	VDD=3.0V	TOI1		10	15	ms
Short circuit detection delay time	VDD=3.0V	TOI2		10	50	μs
<b>OTHER</b>						
OC pin output "H" voltage	VDD=3.9V, Ioh=-50μA	Voh1	3.4	3.7		V
OC pin output "L" voltage	VDD=4.5V, CSI=0V	Vol1		0.1	0.5	V
OD pin output "H" voltage	VDD=3.9V, Ioh=-50μA	Voh2	3.4	3.7		V
OD pin output "L" voltage	VDD=2.0V, Iol=50μA	Vol2		0.1	0.5	V



11. State Diagram of Operation

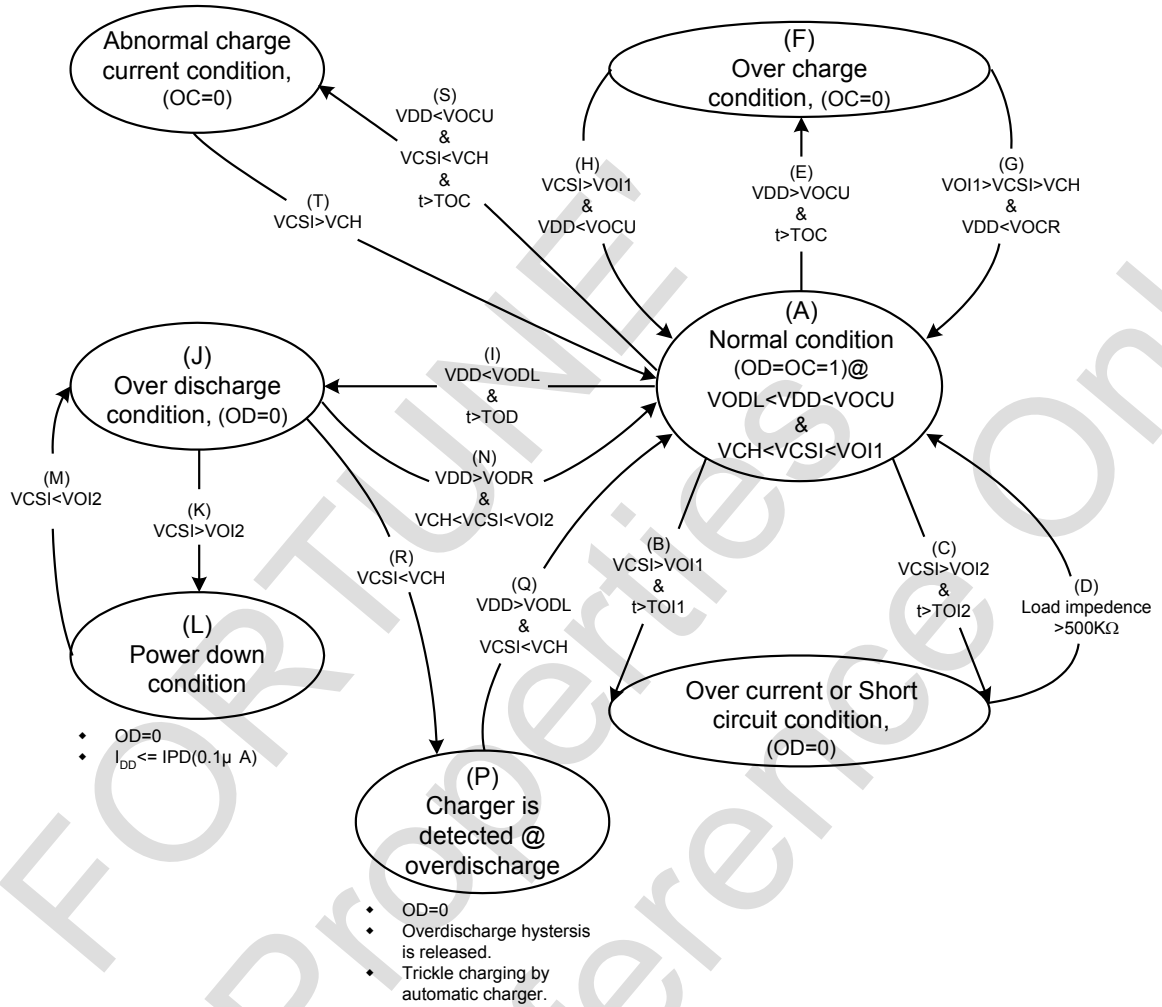

## 12. Description of Operation

### Normal Condition

The FS326 monitors the voltage of the battery connected between VDD and VSS. The charge and discharge scheme will be sensed by the voltage difference between CSI and VSS. When  $VODL < VDD < VOCU$  and  $VCH < VCSI < VOI1$ , FS326 will turn on the charging (M2) and discharging (M1) control MOSFETs. The charging and discharging processes can be operated normally. This is called the normal condition.

Note: When a battery is connected to FS326 for the first time, it may not enter the normal condition (dischargeable may not be enabled). In this case, short the CSI and VSS pins or connect a charger to restore to the normal condition.

### Overcharge Condition

When the battery voltage becomes higher than the overcharge detection voltage (VOCU) during normal charging condition through a delay time longer than TOC (the overcharge detection delay time), FS326 will turn M2 off to stop charging. This condition is called the overcharge condition.

### Release of Overcharge Condition

There are two ways to return to normal condition from overcharge condition.

- 1) When the battery is self discharging, and if  $VDD < VOICR$  and  $VOI1 > VCSI > VCH$  occurs, M2 will be turned on and back to normal condition.
- 2) Remove the charger and connect FS326 to a load, the discharging current will flow through the parasitic diode of M2. At this moment, VCSI increases a voltage (VF) of the parasitic diode from the VSS level momentarily. While  $VCSI > VOI1$  and

$VDD < VOCU$  occurs, M2 will be turned on and back to normal condition.

Note 1: After entering the overcharge condition, if the charger remains connected and  $VOI1 > VCSI > VCH$ , then M2 will be turned on when the voltage of the battery is lower than VOICR (because the self-discharge of the battery). The system can enter the charging status again as 1).

Note 2: After entering the overcharge condition, if the charger remains connected and  $VCSI < VCH$ , then M2 will be kept off even though the voltage of the battery is lower than VOICR (because the self-discharge of the battery), and the system will not be allowed to enter the charging status.

### Overdischarge Condition

When the battery voltage falls below the overdischarge detection voltage (VODL) during discharging condition and through a delay time longer than TOD (the overdischarge detection delay time), FS326 will turn M1 off to stop discharging. This is called the overdischarge condition. In the meanwhile, CSI will be pulled up to VDD through an internal resistance. If  $VCSI > VOI2$ , FS326 will enter into power-down mode. While in this mode, the current consumption is lower than  $0.1 \mu A$ .

### Release of Power-down mode

After entering power-down mode, when the system is connected to a charger, the charging current will flow through the parasitic diode of M1. If  $VCSI > VOI2$  occurs, then FS326 will release power-down mode. While keeping charging status, there are two ways back to normal condition:

- 1) If  $V_{CSI} < V_{CH}$  (Charger detection), then when  $V_{DD} > V_{ODL}$ , M1 will be turned on and the system will back to normal condition.
- 2) If  $V_{CH} < V_{CSI} < V_{OI2}$ , the condition  $V_{DD} > V_{ODR}$  must be satisfied for M1 to be turned on, and then the system will back to the normal condition.

#### Charger Detection

While connecting to a charger after entering into power-down mode, then if  $V_{CSI} < V_{CH}$ , M1 will be turned on when  $V_{DD} > V_{ODL}$ . The system will back to normal condition as described in 1) of previous section since the charger has been detected. This action is called charger detection.

#### Abnormal Charge Current Condition

When a charger is connected to the battery system in normal condition, then if  $V_{DD} < V_{OCU}$  and  $V_{CSI} < V_{CH}$  occurs through a delay time longer than TOC (delay time of overcharge detection), M2 will be turned off to stop this charging status. It is called the abnormal charge current condition.

Abnormal charge current condition is released when the voltage of CSI pin becomes higher than charger detection voltage ( $V_{CH}$ ), or the charger is removed.

#### Over Current / Short Circuit Condition

When the current is too large during discharging under normal condition as a result of the voltage detected by CSI is greater than  $V_{OI1}$  (or  $V_{OI2}$ ) through a delay time  $TOI1$  (or  $TOI2$ ), it satisfies the over current (or short circuit) condition. Then M1 will be turned off and CSI will be pulled down to VSS through an internal resistance. It is called the over current (or short circuit) condition.

- If the over current / short circuit is detected and it keeps longer than the overdischarge detection delay time with the same

circumstance, the condition will be changed to the power-down mode when the battery voltage falls below the overdischarge detection voltage.

- If the battery voltage falls below the overdischarge detection voltage ( $V_{ODL}$ ) due to the over current / short circuit, the discharging control FET (M1) will be turned off when this condition occurs. After overdischarge detection delay time (TOD) expired, if the battery voltage is still equal to or lower than the overdischarge detection voltage, the condition will then be changed to power-down mode.

#### Release of Over Current / Short Circuit Condition

While the protection IC remains in Over current/Short circuit condition, then if the load is removed or the impedance between  $V_{BAT+}$  and  $V_{BAT-}$  is larger than  $500k\Omega$  as well as  $V_{CSI} < V_{OI1}$ , M1 will be turned on and then back to normal condition.

#### DS Pin

By forcing DS to VDD, the delay time of the overcharge and overdischarge can be reduced to within 50ms; therefore, testing time of protector circuit board can be reduced.  $1.6M\Omega$  pull down resistor is connected between DS pin and VSS internally. DS pin should be left open or connected to VSS in the actual application.

### 13. Timing Diagram

Overcharge Condition → Self Discharge → Normal Condition

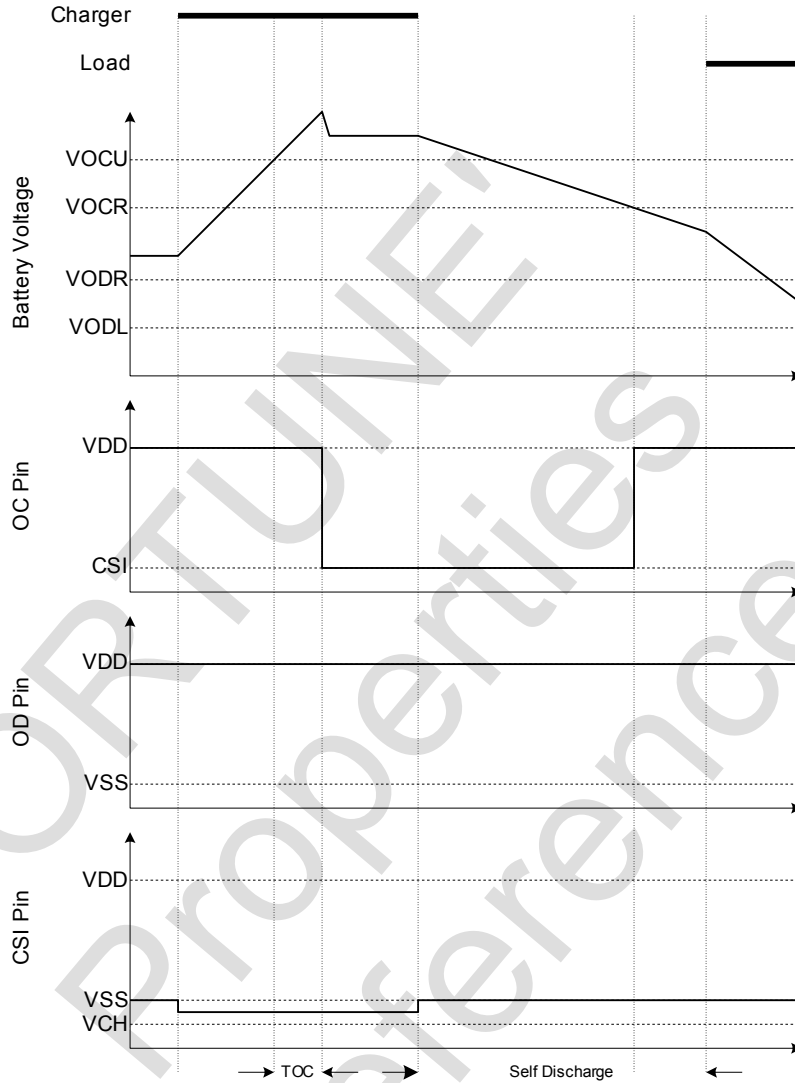

Overcharge Condition → Load Discharge → Normal Condition

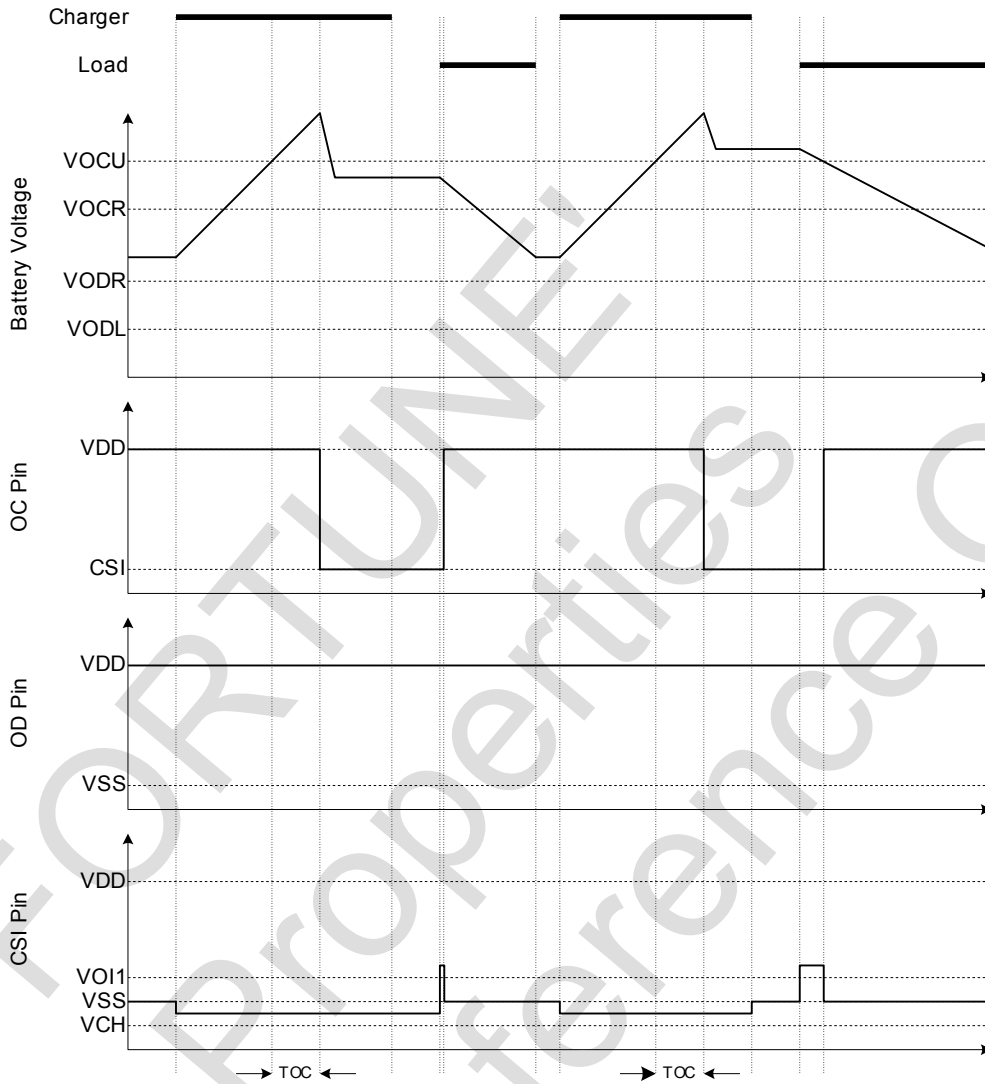

Overcharge Condition → Charger remains connected and  $V_{CSI} > V_{CH}$  → Self Discharge

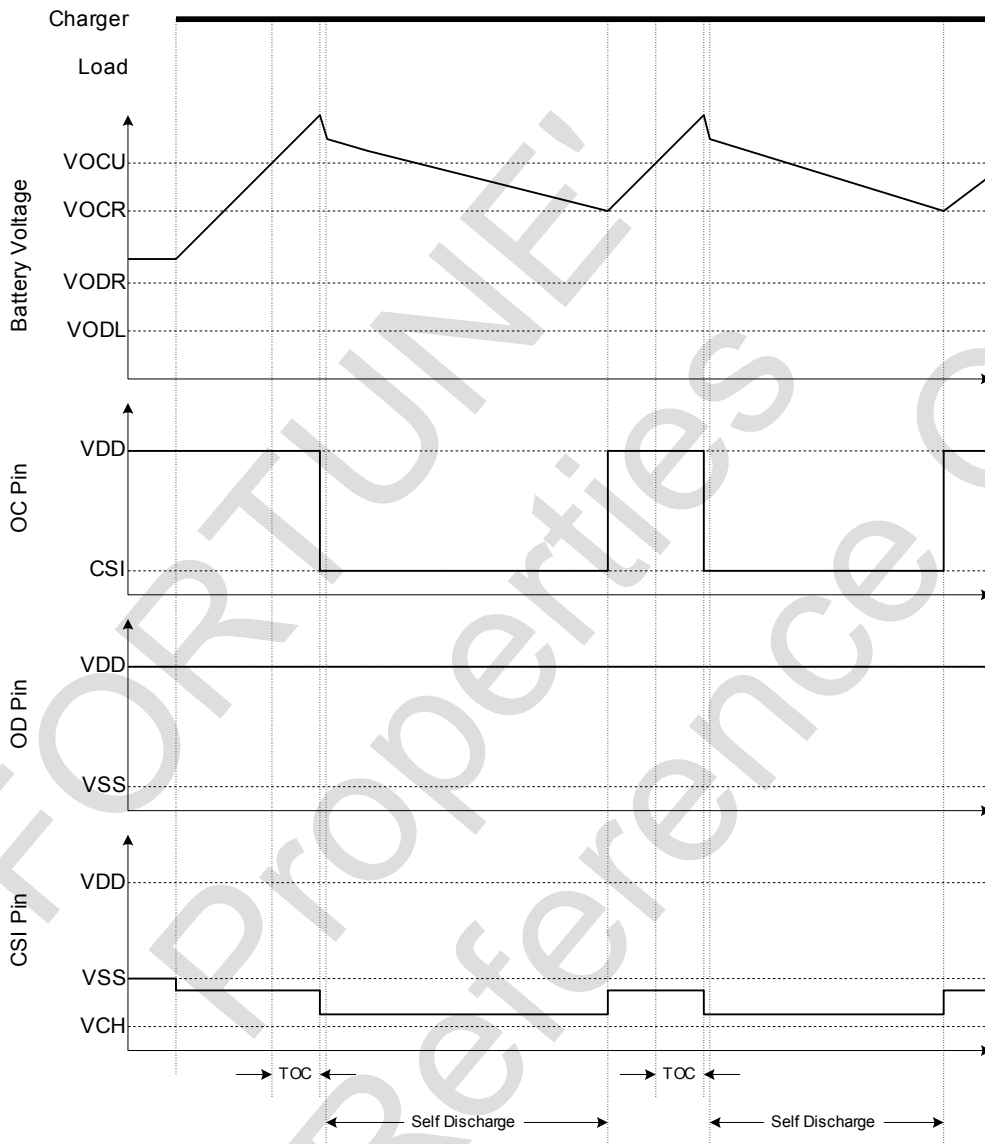

Overcharge Condition → Charger remains connected and  $V_{CSI} < V_{CH}$  → Self Discharge

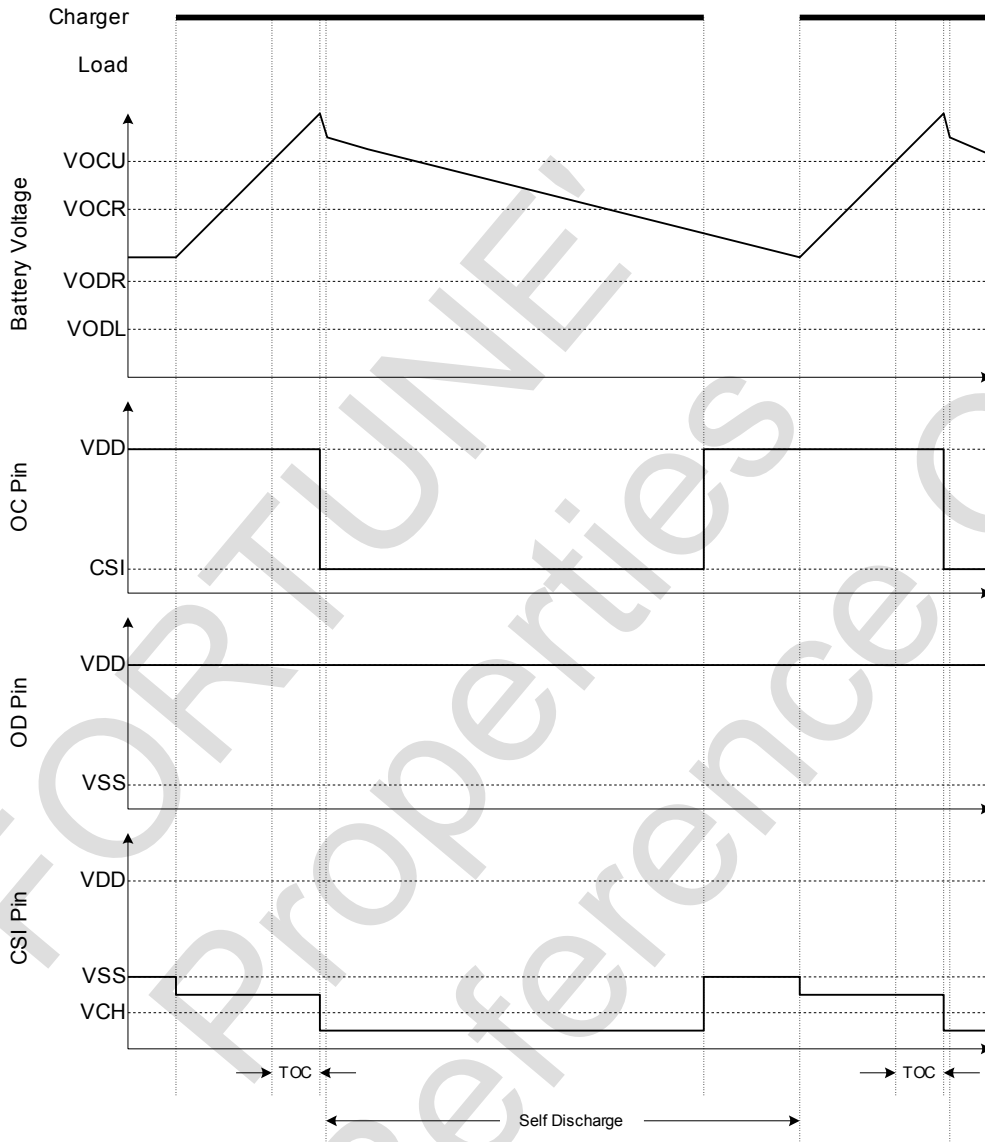

Overdischarge Condition → Charging by a Charger → Normal Condition

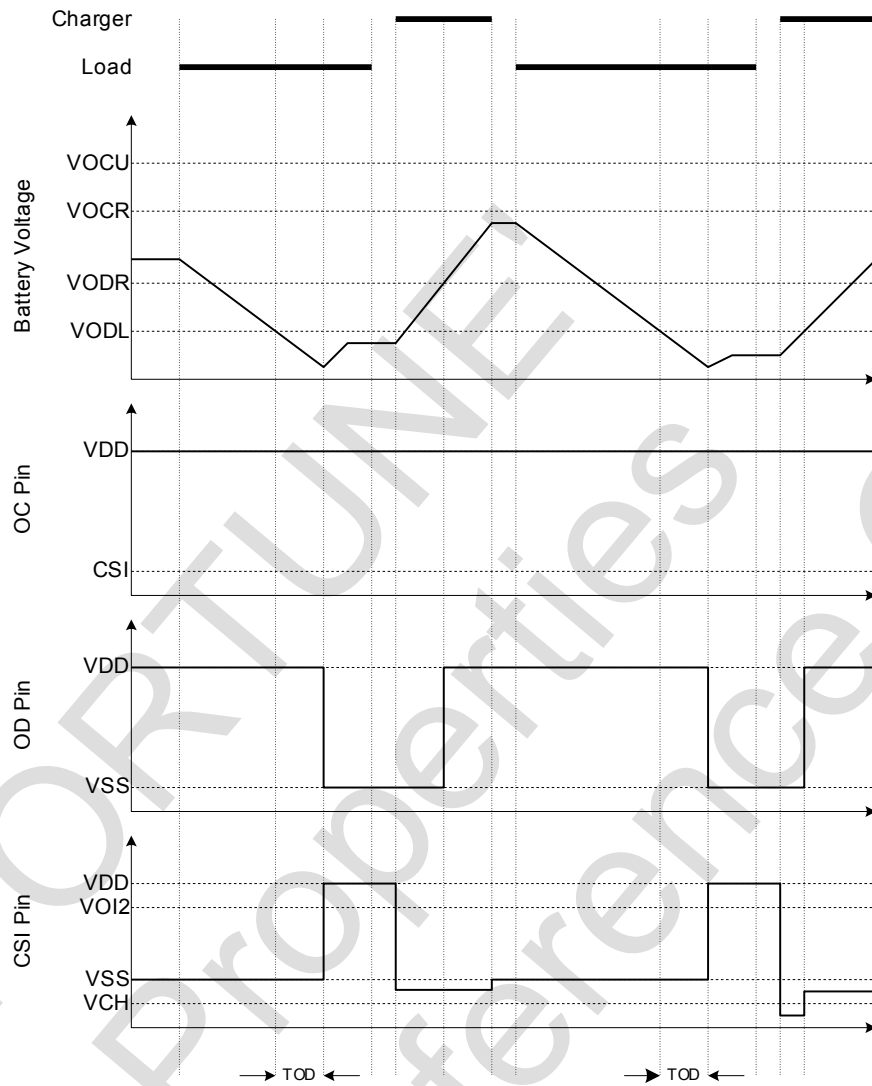



Overdischarge Condition → Abnormal Charge Current Condition → Normal Condition

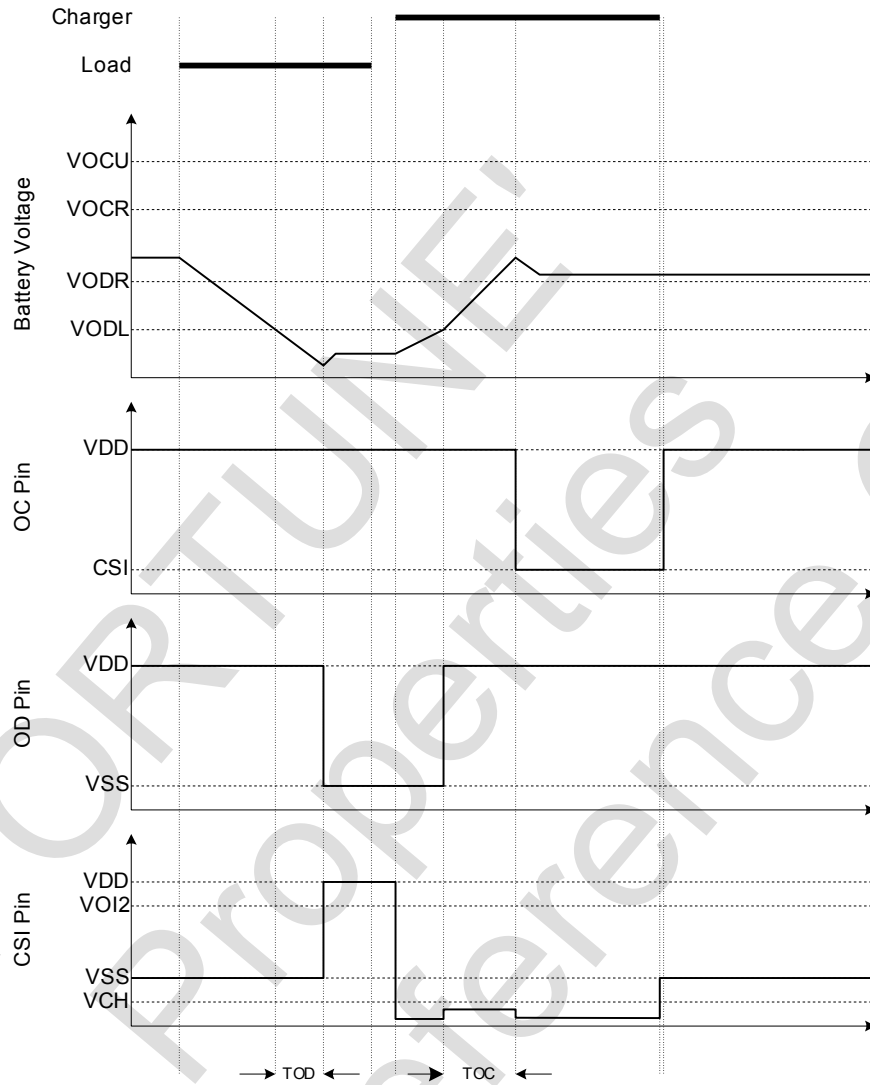

Over Current / Short Circuit Condition → Normal Condition

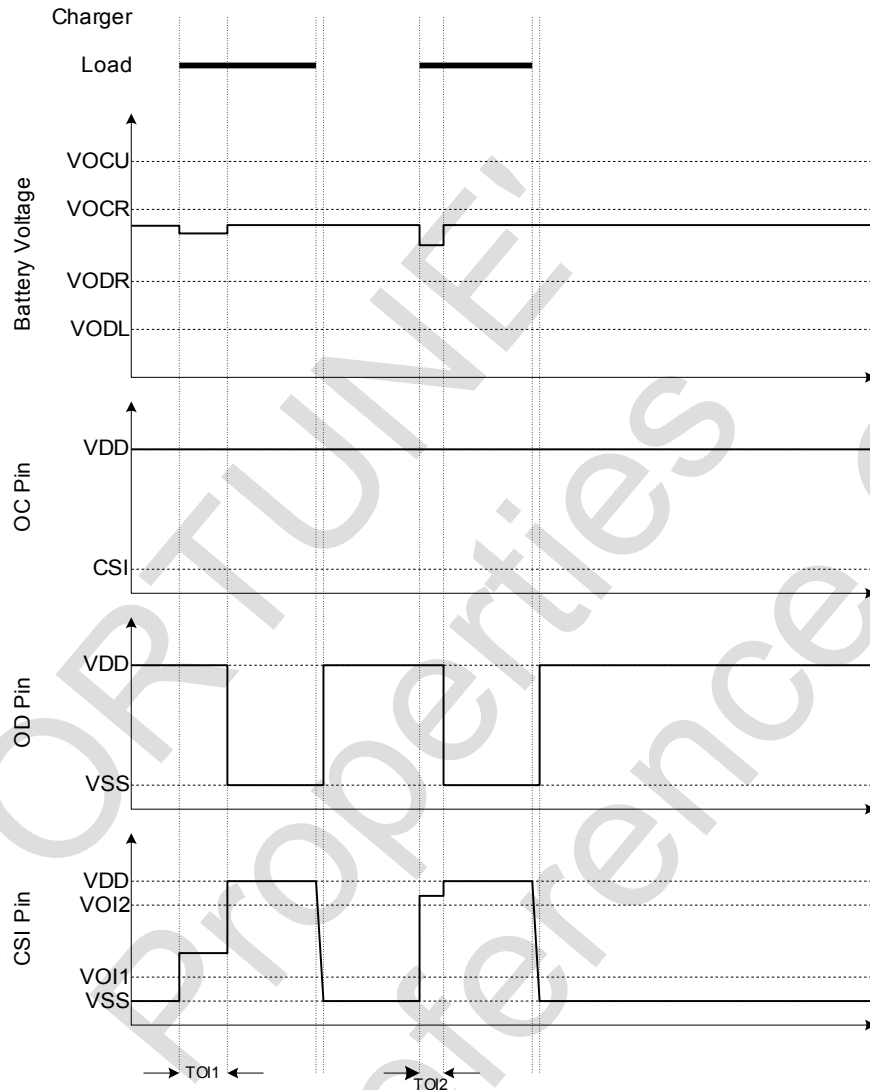

14. Package Outline

Dimension

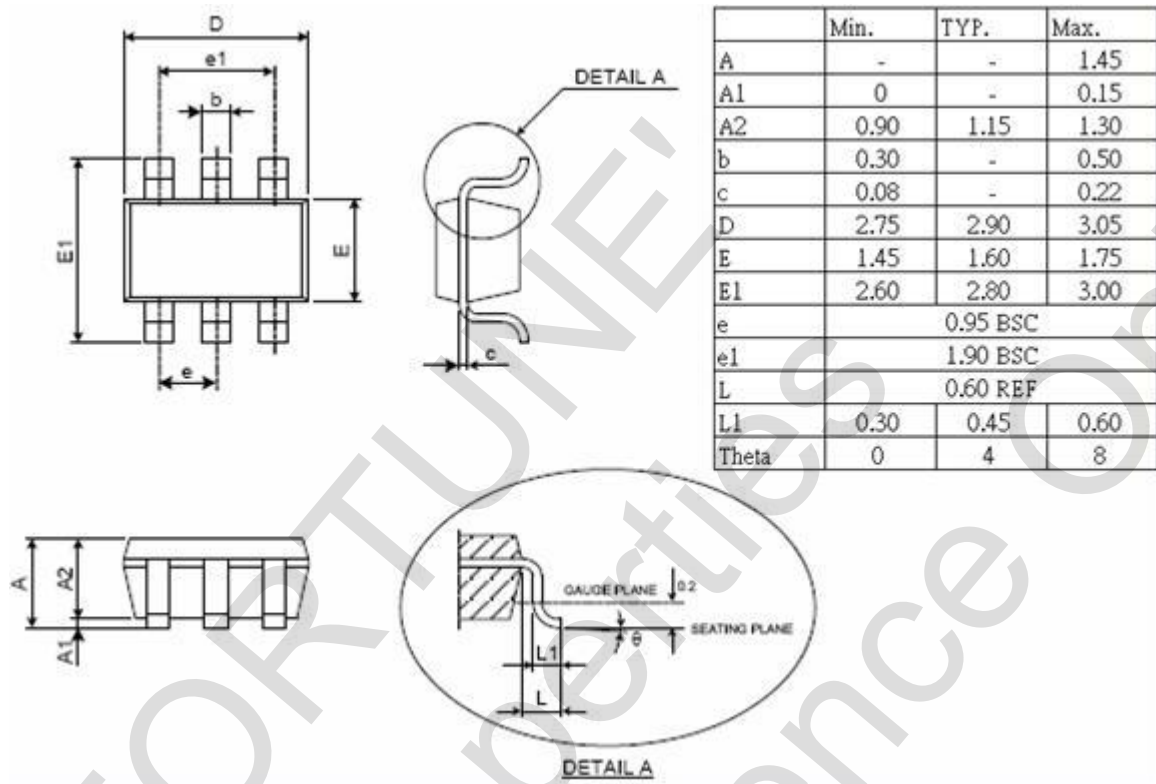

## 15. Revision History

Version	Date	Page	Description
1.1	2003/3/27	2	Adds two new types: 326D and 326E
1.2	2003/5/14	6	Revise VCH / TOC / TOD
1.3	2004/3/15	1	Order information: Added ordering information
		1	Features: [VOCR] → 3.8~4.2V [VODL] → 2.0~2.8V [VODR] → 2.8~3.2V [VOI1] → 0.05~0.2V
		3	Typical Application Circuit: Symbol u changed to μ
		5	Electrical Characteristics: Symbol u changed to μ
		7~8	Description of Operation: Content amendment
1.4	2004/4/23	1	Features: [VOCR] → 3.8~4.2V [VODL] → 2.2~2.6V [VODR] → 2.4~3.2V
		2	Add new F version
1.5	2005/11/17	-	Revise to new datasheet and revision history format
		1	Features: [VODL] → 2.2~2.9V
		2	Add new G version
		6	Add new FS326G electrical characteristics
1.6	2006/06/22	2	Add new FS326H electrical characteristics
		4	Revise Voc and VCSI rating to VCC -24 to VCC +0z.3
		1	Add Pb-free ordering information
1.7	2006/07/06	1	Add Pb-free ordering information
1.8	2007/04/10	-	Revise to new datasheet format
		4	Add package marking information
		7	Add Min spec for delay time (except FS326G)
		20	Add revision history
1.9	2007/04/24	4	Delete FS326A/FS326B/FS326D/FS326E product name
2.0	2009/07/07	4	Update FS326F VOCR : 4.10±0.05V - VODR : 2.90±0.05V
2.1	2011/09/08	19	Revise Package Outline

## X-ON Electronics

Largest Supplier of Electrical and Electronic Components

*Click to view similar products for [Battery Management](#) category:*

*Click to view products by [Fortune](#) manufacturer:*

Other Similar products are found below :

[VN5R003HTR-E](#) [NCP1855FCCT1G](#) [FAN54063UCX](#) [NCP367DPMUEBTBG](#) [LC05132C01NMTTTG](#) [ISL78714ANZ](#) [CM1104-EH](#)  
[CM1104-DBB](#) [CM1104-MBB](#) [XC6801A421MR-G](#) [ISL95521BHRZ](#) [ISL95521BIRZ](#) [MP2639AGR-P](#) [S-82D1AAE-A8T2U7](#) [S-82D1AAA-](#)  
[A8T2U7](#) [S-8224ABA-I8T1U](#) [MC33772CTA1AE](#) [MC33772CTC0AE](#) [BQ28Z610DRZR-R1](#) [MCP73832-4ADI/MC](#) [MCP73832T-2DCIMC](#)  
[MCP73833T-AMIMF](#) [MCP73833T-AMI/UN](#) [MCP73838-NVI/MF](#) [MCP73213-A6BI/MF](#) [MCP73831-2ACI/MC](#) [MCP73831T-2ATIMC](#)  
[MCP73832-2ACI/MC](#) [MCP73832T-3ACIMC](#) [MCP73833T-FCI/MF](#) [MCP73853-IML](#) [BQ25895RTWR](#) [BQ29704DSER](#) [BQ78Z100DRZR](#)  
[ISL78610ANZ](#) [FAN5403UCX](#) [NCP367DPMUECTBG](#) [FAN54015BUCX](#) [MAX8934BETI+](#) [BQ24311DSGR](#) [BQ25100HYFPR](#)  
[BQ29707DSER](#) [MAX17048G+T10](#) [BQ24130RHRLR](#) [BQ25120AYFPR](#) [BQ29703DSER](#) [BQ771807DPJR](#) [BQ25120AYFPT](#)  
[MAX17055ETB+T](#) [MAX17710GB+T](#)