

IDEAS GENERATED DRAWING, DON'T CHANGE BY HAND.

REV.	ECN. NO.	APPD.
A	BC-11-0059945	L.C.WU
B	BC-11-0123310	L.C.WU
C	BC-12-0050281	L.C.WU

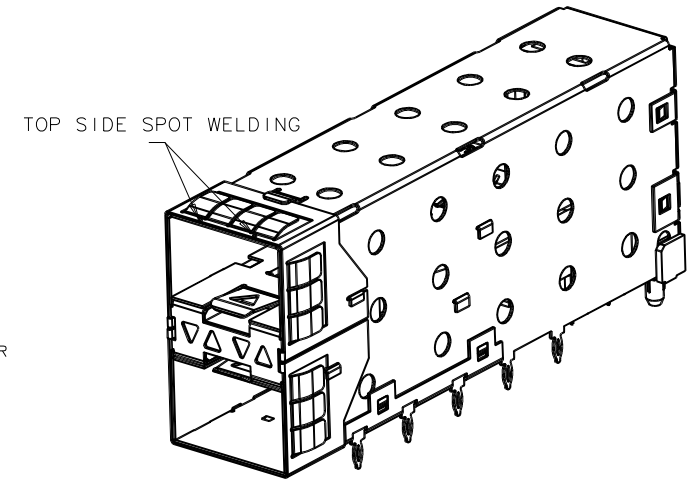

SFP PLUS 2X1 CAGE&CONNECTOR WITH LIGHT PIPE  
P/N: 3S1020F\*-AJ4-4F

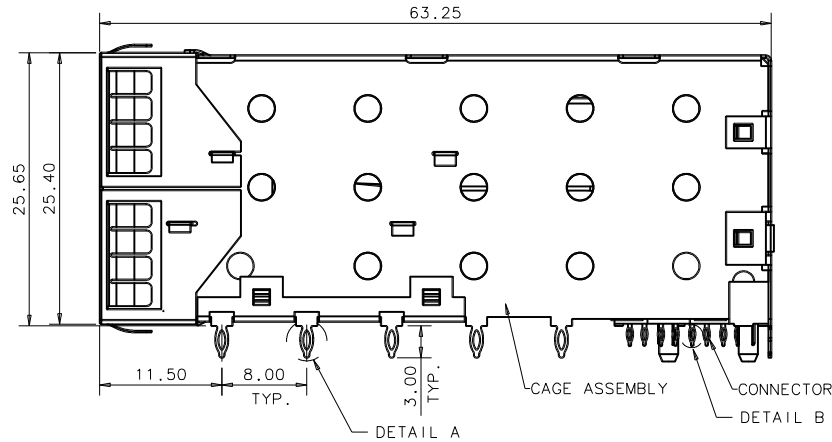
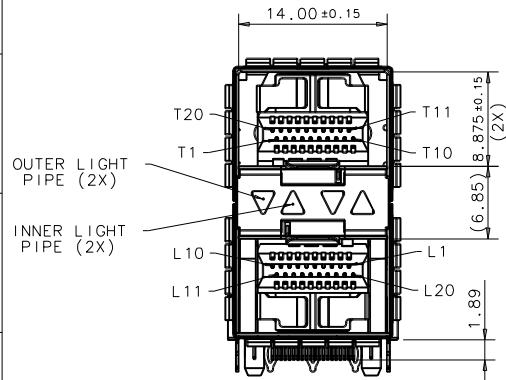
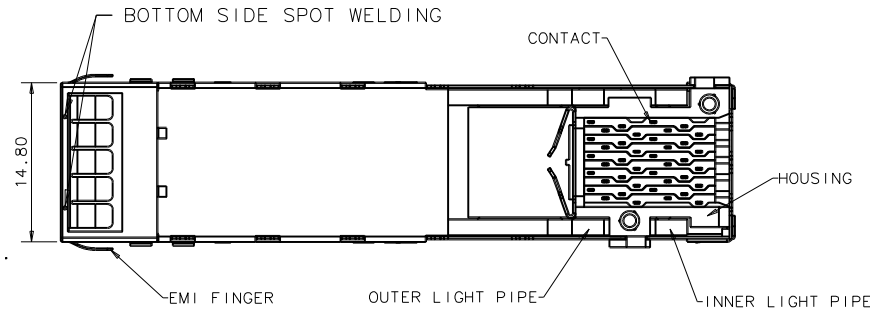

NOTES, UNLESS OTHERWISE SPECIFIED:

1. MATERIAL:

CONNECTOR HOUSING: THERMAL PLASTIC, UL94 V-0.

CONTACT: COPPER ALLOY.

CONNECTOR I/M: THERMAL PLASTIC, UL94 V-0

CAGE ASSEMBLY: COPPER ALLOY

LIGHT PIPE: POLYCARBONITE, UL94 V-0.

2. FINISH:

CONTACT:

1) 50u" MIN. NICKEL UNDER PLATING.

2) 30u" MIN. TIN/LEAD OR TIN PLATING AT PRESS FIT AREA.

3) 30u" NOMINAL GOLD PLATING AT CONTACT AREA.

CAGE: 50u" NICKEL PLATING OVER ALL.

3. PRESS FIT HOLES:

CONTACT:

1) HOLE DIAMETER AFTER PLATING: 0.41~0.51mm.

2) DRILLED HOLE: 0.535~0.585mm.

CAGE:

1) HOLE DIAMETER AFTER PLATING: 1.00~1.10mm.

2) DRILLED HOLE: 1.125~1.175mm.

PART LIST

3S1020F* - AJ4 - 4 F	F: 2X1, SFP PLUS	F: LEAD FREE CODE F: LEAD FREE
	3: 30u" GOLD PLATING	PACKAGE TYPE
	7: 15u" GOLD PLATING	4: TRAY
A: CAGE/CONNECTOR INTEGRAL		
J: EMI FINGER TYPE WITH LIGHT PIPE		

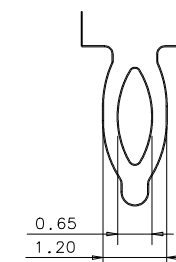

DETAIL A  
SCALE 10:1

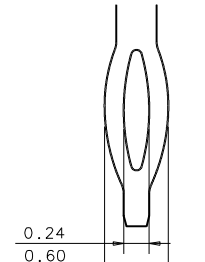

DETAIL B  
SCALE 20:1

X. ±	X.° ± 5°	UNITS	NAME (INTENDED USE)	FOXCONN
.X ± 0.20	.X° ± 3°	mm	SFP PLUS 2X1 CONN & CAGE	HON HAI PRECISION IND. CO., LTD. TAIPEI, TAIWAN, R.O.C.
.XX ± 0.15	.XX° ±	MAT'L	PART NO. (INTENDED USE)	TITLE:
.XXX ±	.XXX° ±	FINISH	3S1020F* - **4-4F	CUSTOMER DRAWING
THESE DRAWINGS AND SPECIFICATIONS ARE THE PROPERTY OF HON HAI PRECISION IND. CO., LTD. AND SHALL NOT BE REPRODUCED, COPIED OR USED IN ANY MANNER WITHOUT THE PRIOR WRITTEN CONSENT OF HON HAI PRECISION IND. CO., LTD.			APPD: L.C.WU 07/23'12	DWG NO.:
			CHKD: PIER HSU 07/23'12	323-0000-1726
			DR: CALVIN 07/23'12	SCALE SHEET REV.
			⊕	N/A 1/6 C

IDEAS GENERATED DRAWING, DON'T CHANGE BY HAND.

REV.	ECN. NO.	APPD.

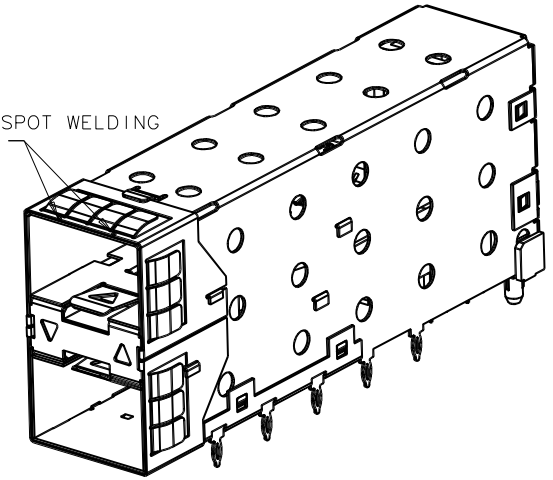
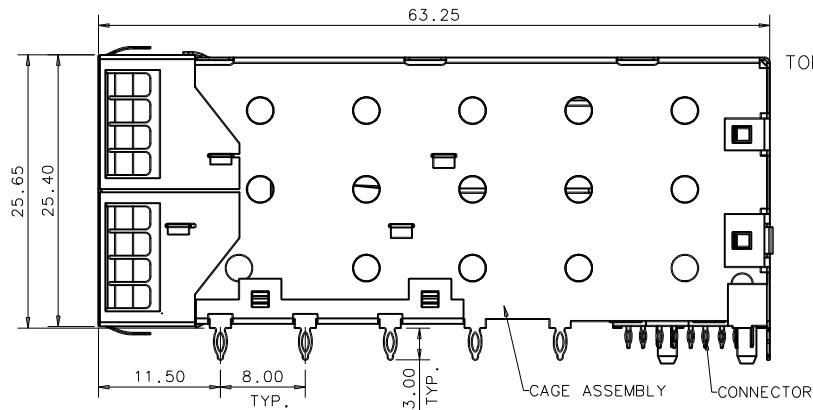
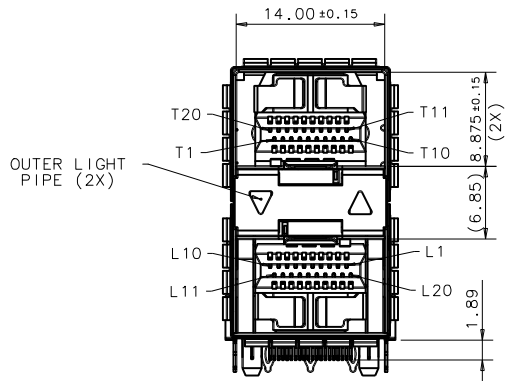

SFP PLUS 2X1 CAGE&CONNECTOR WITH LIGHT PIPE  
 P/N: 3S1020F\*-HJ4-4F

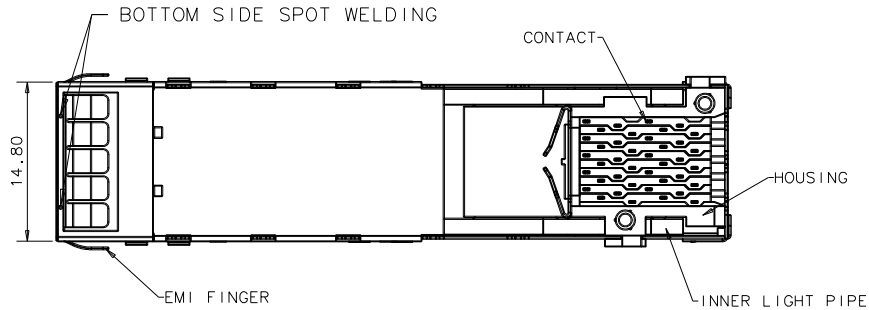

PART LIST

3S1020F\* - C J 4 - 4 F  
 F: 2X1, SFP PLUS  
 3: 30u" GOLD PLATING  
 7: 15u" GOLD PLATING  
 C: WITH OUTER LIGHT PIPE  
 J: EMI FINGER TYPE WITH LIGHT PIPE  
 LEAD FREE CODE F: LEAD FREE  
 PACKAGE TYPE 4: TRAY

X. ±	X.° ± 5°	UNITS mm	NAME (INTENDED USE)	<b>FOXCONN</b> HON HAI PRECISION IND. CO., LTD. TAIPEI, TAIWAN, R.O.C.	
.X ± 0.20	.X° ± 3°	MAT'L	SFP PLUS 2X1 CONN & CAGE		
.XX ± 0.15	.XX° ±	FINISH △	PART NO. (INTENDED USE)	TITLE:	
.XXX ±	.XXX° ±		3S1020F* - **4-4F	CUSTOMER DRAWING	
THESE DRAWINGS AND SPECIFICATIONS ARE THE PROPERTY OF HON HAI PRECISION IND. CO., LTD. AND SHALL NOT BE REPRODUCED, COPIED OR USED IN ANY MANNER WITHOUT THE PRIOR WRITTEN CONSENT OF HON HAI PRECISION IND. CO., LTD.			APPD: L.C.WU 07/23'12	DWG NO.:	
			CHKD: PIER HSU 07/23'12	323-0000-1726	
			DR: CALVIN 07/23'12		
			SCALE	SHEET	REV.
			N/A	2/6	C

IDEAS GENERATED DRAWING, DON'T CHANGE BY HAND.

REV.	ECN. NO.	APPD.
------	----------	-------

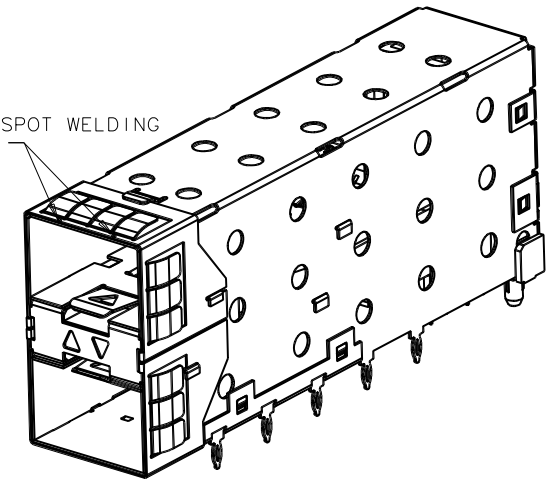
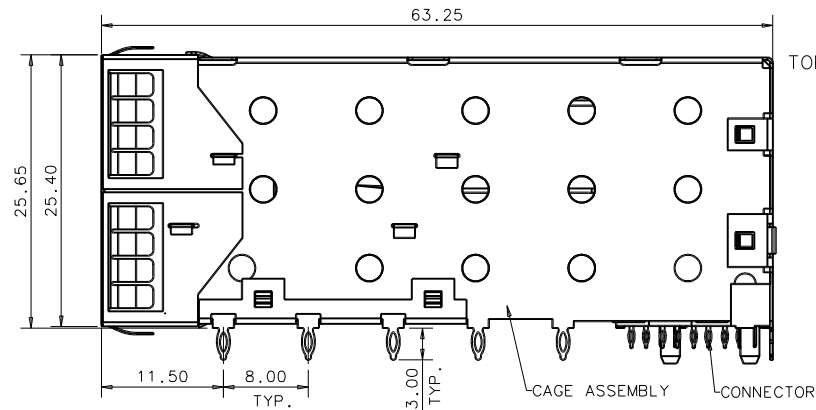
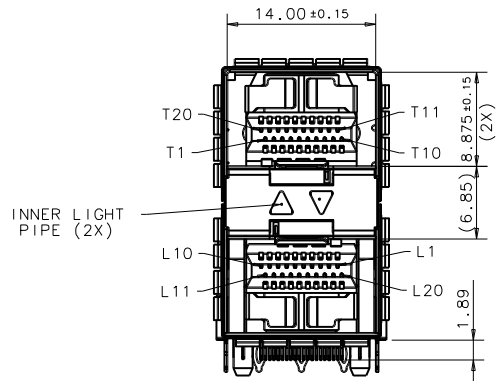

SFP PLUS 2X1 CAGE&CONNECTOR  
WITH LIGHT PIPE  
P/N: 3S1020F\*-BJ4-4F

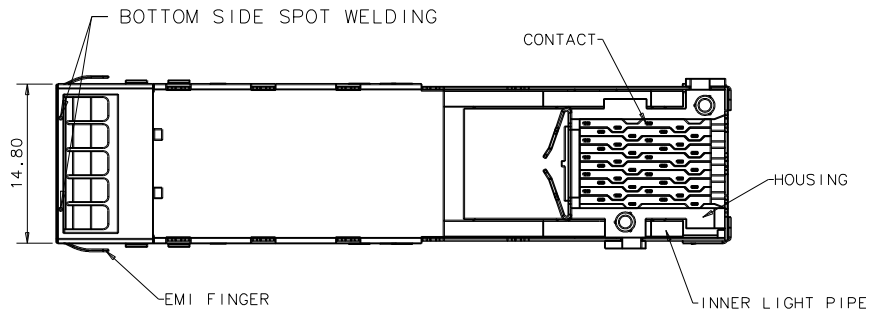

PART LIST

3S1020F\* - BJ4 - 4 F

F: 2X1, SFP PLUS

3: 30u" GOLD PLATING

7: 15u" GOLD PLATING

B: WITH INNER LIGHT PIPE

J: EMI FINGER TYPE WITH LIGHT PIPE

LEAD FREE CODE  
F: LEAD FREE

PACKAGE TYPE  
4: TRAY

X. ±	X.° ± 5°	UNITS mm	NAME (INTENDED USE)	<b>FOXCONN</b> HON HAI PRECISION IND. CO., LTD. TAIPEI, TAIWAN, R.O.C.	
.X ± 0.20	.X° ± 3°	MAT'L	SFP PLUS 2X1 CONN & CAGE		
.XX ± 0.15	.XX° ±	FINISH △	PART NO. (INTENDED USE)	TITLE:	
.XXX ±	.XXX° ±		3S1020F*-**4-4F	CUSTOMER DRAWING	
THESE DRAWINGS AND SPECIFICATIONS ARE THE PROPERTY OF HON HAI PRECISION IND. CO., LTD. AND SHALL NOT BE REPRODUCED, COPIED OR USED IN ANY MANNER WITHOUT THE PRIOR WRITTEN CONSENT OF HON HAI PRECISION IND. CO., LTD.			APPD: L.C.WU 07/23'12	DWG NO.:	
			CHKD: PIER HSU 07/23'12	323-0000-1726	
			DR: CALVIN 07/23'12		
			SCALE	SHEET	REV.
			N/A	3/6	C

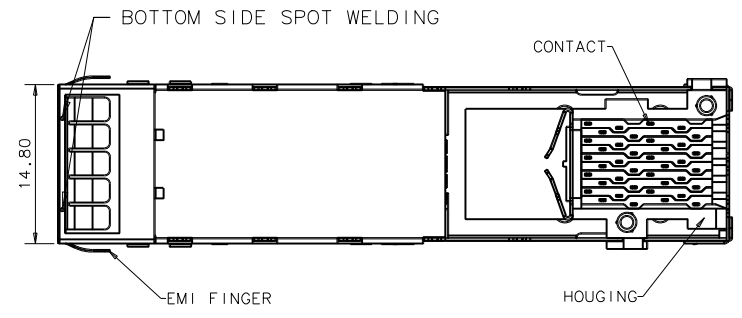
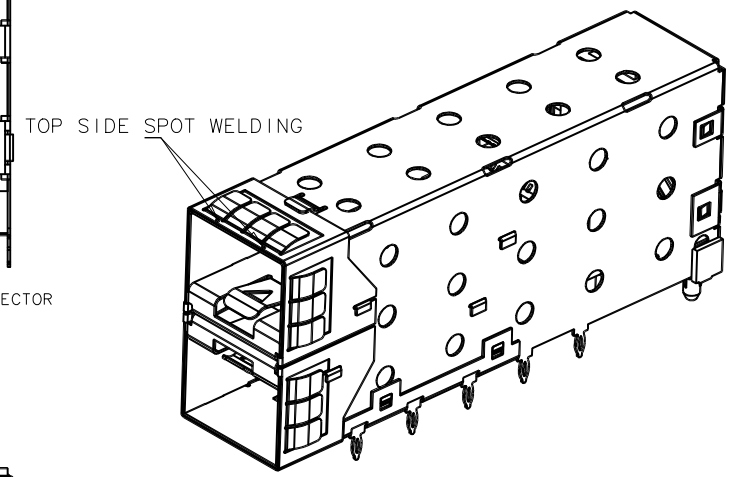
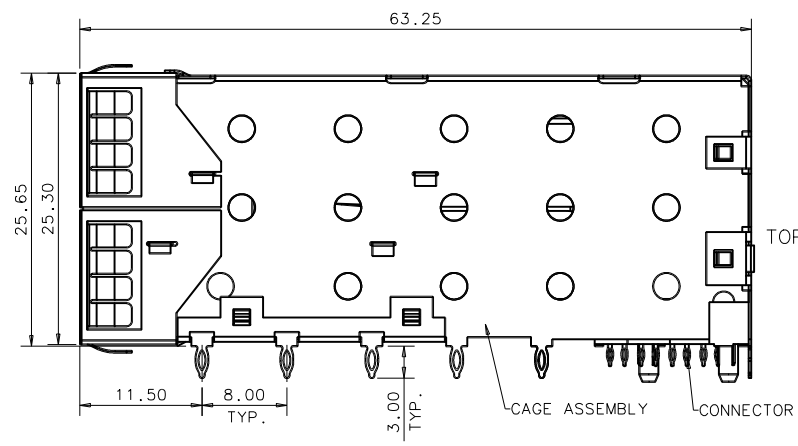
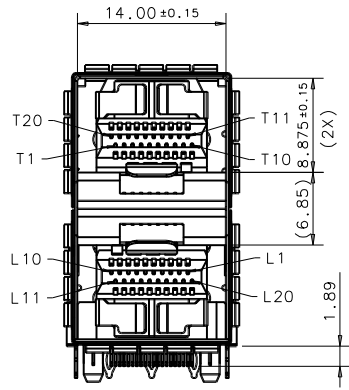

SFP PLUS 2X1 CAGE&CONNECTOR  
WITHOUT LIGHT PIPE  
P/N: 3S1020F\*-AE4-4F

PART LIST

- 3S1020F\* - AE4 - 4 F
- F: 2X1, SFP PLUS
  - 3: 30u" GOLD PLATING
  - 7: 15u" GOLD PLATING
  - A: CAGE/CONNECTOR INTEGRAL
  - E: EMI FINGER TYPE WITHOUT LIGHT PIPE
  - LEAD FREE CODE
  - F: LEAD FREE
  - PACKAGE TYPE
  - 4: TRAY

X. ±	X.° ± 5°	UNITS mm	NAME (INTENDED USE)	<b>FOXCONN</b> HON HAI PRECISION IND. CO., LTD. TAIPEI, TAIWAN, R.O.C.	
.X ± 0.20	.X° ± 3°	MAT'L	SFP PLUS 2X1 CONN & CAGE		
.XX ± 0.15	.XX° ±	FINISH	PART NO. (INTENDED USE)	TITLE:	
.XXX ±	.XXX° ±		3S1020F* - **4 - 4F	CUSTOMER DRAWING	
THESE DRAWINGS AND SPECIFICATIONS ARE THE PROPERTY OF HON HAI PRECISION IND. CO., LTD. AND SHALL NOT BE REPRODUCED, COPIED OR USED IN ANY MANNER WITHOUT THE PRIOR WRITTEN CONSENT OF HON HAI PRECISION IND. CO., LTD.			APPD: L.C.WU 07/23'12	DWG NO.:	
			CHKD: PIER HSU 07/23'12	323-0000-1726	
			DR: CALVIN 07/23'12		
			SCALE	SHEET	REV.
			N/A	4/6	C

IDEAS GENERATED DRAWING, DON'T CHANGE BY HAND.

REV. ECN. NO. APPD.

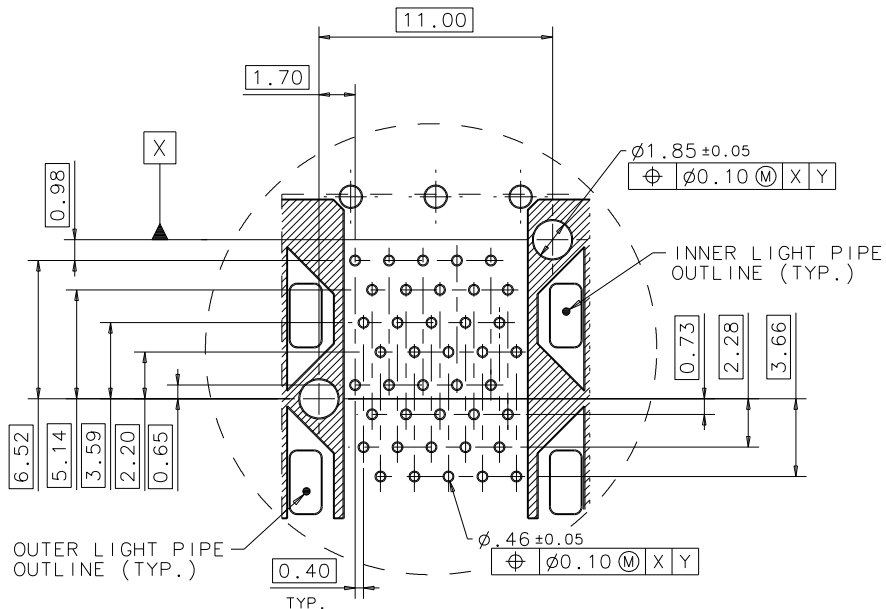

DETAIL A

OUTER LIGHT PIPE OUTLINE (TYP.)

$\phi 1.85 \pm 0.05$   
 $\phi 0.10$

INNER LIGHT PIPE OUTLINE (TYP.)

$\phi 4.6 \pm 0.05$   
 $\phi 0.10$

TYP.  $\phi 1.05 \pm 0.05$   
 $\phi 0.10$

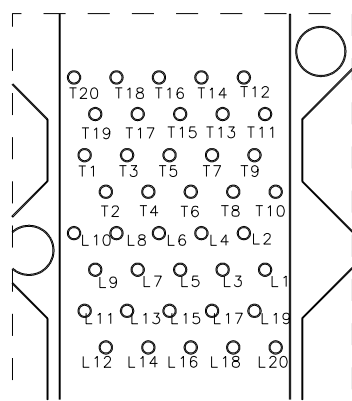

DETAIL B

CONNECTOR PIN-OUT  
COMPONENT SIDE OF BOARD

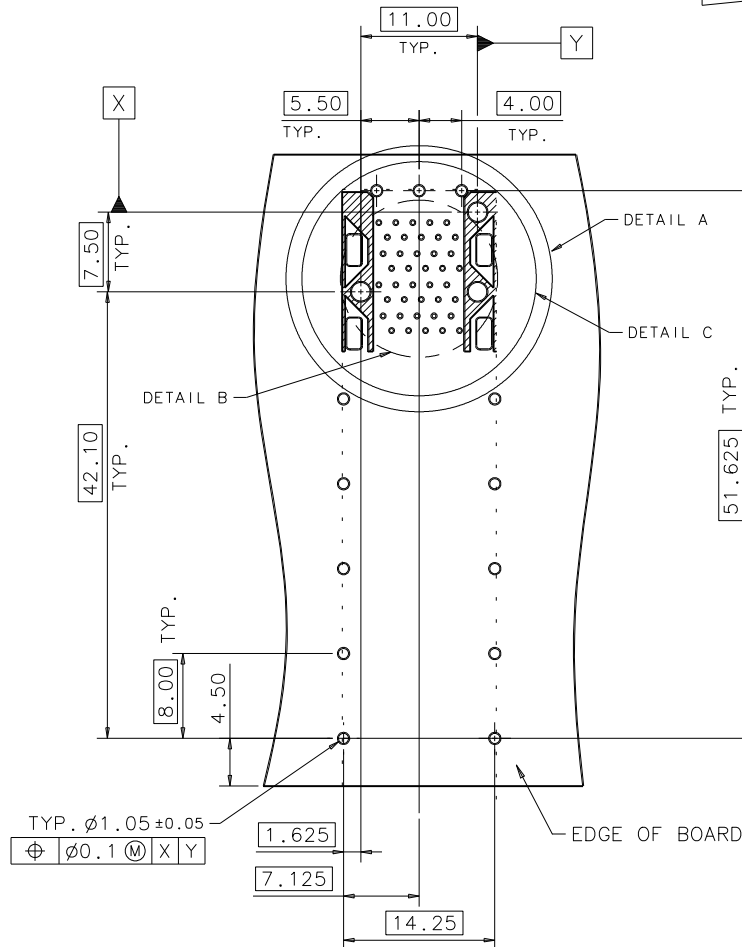

RECOMMENDED HOST BOARD LAYOUT

- NOTES:
4. PCB THICKNESS TO BE 1.57MM MINIMUM.
  5. THE AREA, INDICATED BY THE DASHED LINE, TO BE CONNECTOR OR CAGE ASSEMBLY FOOTPRINT, SHALL BE CONSIDERED KEEPOUT AREA FOR COMPONENTS AND SINGLE TRACES.

X. ±	X.° ± 5°	UNITS mm	NAME (INTENDED USE)	FOXCONN
.X ± 0.20	.X° ± 3°	MATERIAL	SFP PLUS 2X1 CONN & CAGE	HON HAI PRECISION IND. CO., LTD. TAIPEI, TAIWAN, R.O.C.
.XX ± 0.15	.XX° ±		PART NO. (INTENDED USE)	TITLE:
.XXX ±	.XXX° ±	FINISH	3S1020F***4-4F	CUSTOMER DRAWING
			APPD: L.C.WU 07/23'12	DWG NO.:
Q'TY			CHKD: PIER HSU 07/23'12	323-0000-1726
			DR: CALVIN 07/23'12	SCALE SHEET REV.
				N/A 5/6 C

THESE DRAWINGS AND SPECIFICATIONS ARE THE PROPERTY OF HON HAI PRECISION IND. CO., LTD. AND SHALL NOT BE REPRODUCED, COPIED OR USED IN ANY MANNER WITHOUT THE PRIOR WRITTEN CONSENT OF HON HAI PRECISION IND. CO., LTD.

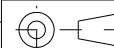

SCALE SHEET REV.  
N/A 5/6 C

IDEAS GENERATED DRAWING, DON'T CHANGE BY HAND.

REV.	ECN. NO.	APPD.

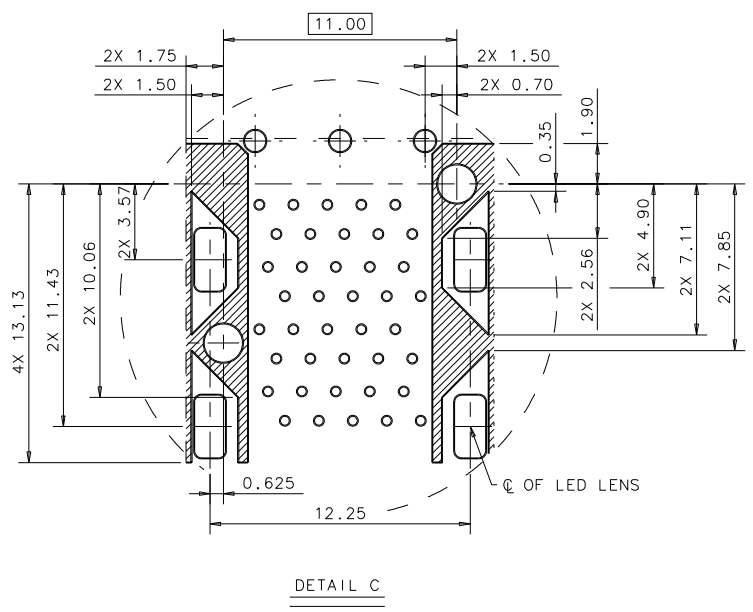
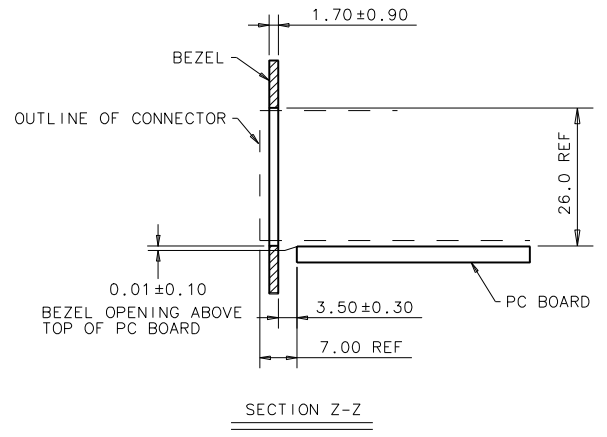
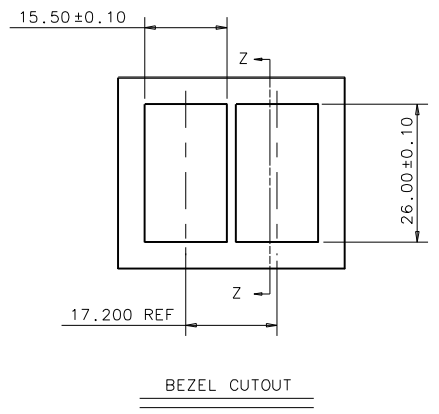

X. ±	X. ° ± 5°	UNITS mm	NAME (INTENDED USE)	<b>FOXCONN</b> HON HAI PRECISION IND. CO., LTD. TAIPEI, TAIWAN, R.O.C.
.X ± 0.20	.X ° ± 3°	MAT'L	SFP PLUS 2X1 CAGE & CONN.	
.XX ± 0.15	.XX ° ±	FINISH	PART NO. (INTENDED USE)	TITLE:
.XXX ±	.XXX ° ±		APPD: L.C.WU 07/23'12	3S1020F*-**4-4F
THESE DRAWINGS AND SPECIFICATIONS ARE THE PROPERTY OF HON HAI PRECISION IND. CO., LTD. AND SHALL NOT BE REPRODUCED, COPIED OR USED IN ANY MANNER WITHOUT THE PRIOR WRITTEN CONSENT OF HON HAI PRECISION IND. CO., LTD.			Q'TY	DWG NO.:
			CHKD: PIER HSU 07/23'12	323-0000-1726
			DR: CALVIN 07/23'12	SCALE SHEET REV.
				N/A 6/6 C

## X-ON Electronics

Largest Supplier of Electrical and Electronic Components

*Click to view similar products for [Fiber Optic Transmitters, Receivers, Transceivers](#) category:*

*Click to view products by [Foxconn](#) manufacturer:*

Other Similar products are found below :

[FWLF-1521-7D-47](#) [FWLF-1521-7D-61](#) [HFBR-1532ETZ](#) [HFBR-2541ETZ](#) [HFBR-2602Z](#) [AFBR-0548Z](#) [AFBR-1639Z](#) [AFBR-1539Z](#) [AFBR-2634Z](#) [AFCT-5962ATLZ](#) [FTLX3813M354](#) [HFBR-2531ETZ](#) [STV.2413-574-00262](#) [TRPRG1VA1C000E2G](#) [TORX1952\(6M,F\)](#)  
[TOTX1350\(F\)](#) [TOTX1350\(V,F\)](#) [FTLX3813M349](#) [HFBR-2542ETZ](#) [SCN-1428SC](#) [AFBR-POC406L](#) [HFBR-2506AFZ](#) [FTLX1871M3BNL](#)  
[FWLF-1521-7D-49](#) [HFBR-1542ETZ](#) [FWLF-1519-7D-49](#) [HFBR-2532ETZ](#) [AFBR-1541CZ](#) [TORX1355\(V,F\)](#) [AFBR-1521CZ](#) [LTK-ST11MB](#)  
[TORX1355\(F\)](#) [HFD8003-002/XBA](#) [HFD3020-500-ABA](#) [S6846](#) [SCN-2638SC](#) [FTL410QE4N](#) [SCN-1570SC](#) [SCN-1601SC](#) [SCN-1338SC](#)  
[HFBR-1505CFZ](#) [AFBR-1528CZ](#) [AFBR-1531CZ](#) [HFD3081-108-XBA](#) [HFD8003-500-XBA](#) [SCN-1255SC](#) [SCN-1383SC](#) [1019682](#) [1019683](#)  
[1019705](#)