

RECOMMENDED P.C.B. HOLE LAYOUT

NOTES:

1. DIMENSIONS SHALL BE INTERPRETED PER ANSI Y14.5M-1994.
2. MATERIALS OF ① AND ② ARE SHOWN ON DRAWING "307-0500-214".
3. SPECIFICATION OF PRODUCTS ARE SHOWN ON DRAWING "307-0300-214".
4. HARMFUL MATERIAL CONTROL PLEASE FOLLOW FOXCONN'S DOC. "EPI12".
5. PLEASE CONTACT FOXCONN SALES REPRESENTATIVE TO VERIFY PRODUCT DETAILS & AVAILABILITY.
6. PRODUCT No. MATRIX: HC ** ** *-*****

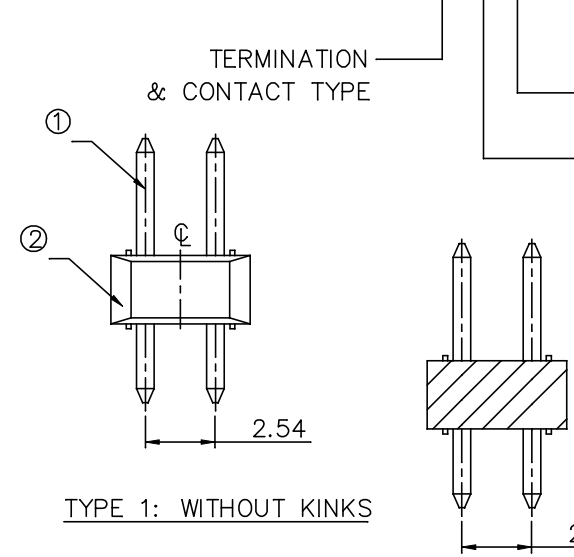

TYPE 1: WITHOUT KINKS

SECTION : A-A
TYPE 1: WITHOUT KINKS

REV.	ECN. No.	APPD.
A	HC95573	Jeff 4/14'95
B	IC027102	Yihsin Chen 10/14'02
C	HC044521	Ady Zhou 10/13'04
D	BC-07-702744	Yusan
E	BC-14-0020595	Shih-Wei Hsiao

OPTIONAL FOR MODIFICATION CODE
SEE DRAWING "307-0000-209"
PLATING CODE
SEE DRAWING "307-0500-214"
No. OF SINGLE ROW POS.
02= 4 POS.
03= 6 POS.
04= 8 POS.
...
40= 80 POS.

PROD. No.	DIM.C	DIM.D
HC01***-*****	5.84	2.54
HC08***-*****	8.08	2.79
HC11***-*****	5.84	2.79
HC12***-*****	5.84	3.18
HC13***-*****	8.08	3.18

X.±	X° ± 2°	UNITS mm	NAME(INTENDED USE) HEADER CONN.	FOXCONN FOXCONN INTERCONNECT TECHNOLOGY LIMITED.
.X ± 0.25	.X° ±	MAT'L	PART NO.(INTENDED USE) HC01/08/11/ 12/13 SERIES	
.XX ± 0.13	.XX° ±	FINISH	APPD: Shih-Wei Hsiao	CLASS: <input type="checkbox"/> CONFIDENTIAL <input type="checkbox"/> SECRET <input checked="" type="checkbox"/> GENERAL
.XXX ±	.XXX° ±		Q'TY	CHKD: Yen-Chi.Chang
THESE DRAWINGS AND SPECIFICATIONS ARE THE PROPERTY OF FOXCONN INTERCONNECT TECHNOLOGY LIMITED. AND SHALL NOT BE REPRODUCED, COPIED OR USED IN ANY MANNER WITHOUT THE PRIOR WRITTEN CONSENT OF FOXCONN INTERCONNECT TECHNOLOGY LIMITED.			DR: Xu Liu 06/22'17	DWG NO.: 307-0000-214

REV.	ECN. No.	APPD.

PROD. No.	CIRCUITS	DIM.A	DIM.B
HC**02* -*****	2	2.54	4.83
HC**03* -*****	3	5.08	7.37
HC**04* -*****	4	7.62	9.91
HC**05* -*****	5	10.16	12.45
HC**06* -*****	6	12.70	14.99
HC**07* -*****	7	15.24	17.53
HC**08* -*****	8	17.78	20.07
HC**09* -*****	9	20.32	22.61
HC**10* -*****	10	22.86	25.15
HC**11* -*****	11	25.40	27.69
HC**12* -*****	12	27.94	30.23
HC**13* -*****	13	30.48	32.77
HC**14* -*****	14	33.02	35.31
HC**15* -*****	15	35.46	37.85
HC**16* -*****	16	38.10	40.39
HC**17* -*****	17	40.64	42.93
HC**18* -*****	18	43.18	45.47
HC**19* -*****	19	45.72	48.01
HC**20* -*****	20	48.26	50.55

PROD. No.	CIRCUITS	DIM.A	DIM.B
HC**21* -*****	21	50.80	53.09
HC**22* -*****	22	53.34	55.63
HC**23* -*****	23	55.88	58.17
HC**24* -*****	24	58.42	60.71
HC**25* -*****	25	60.96	63.25
HC**26* -*****	26	63.50	65.79
HC**27* -*****	27	66.04	68.33
HC**28* -*****	28	68.58	70.87
HC**29* -*****	29	71.12	73.41
HC**30* -*****	30	73.66	75.95
HC**31* -*****	31	76.20	78.49
HC**32* -*****	32	78.74	81.03
HC**33* -*****	33	81.28	83.57
HC**34* -*****	34	83.82	86.11
HC**35* -*****	35	86.36	88.65
HC**36* -*****	36	88.90	91.19
HC**37* -*****	37	91.44	93.73
HC**38* -*****	38	93.98	96.27
HC**39* -*****	39	96.52	98.81
HC**40* -*****	40	99.06	101.35

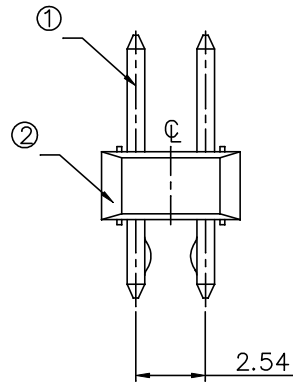

TYPE 2: WITH KINKS

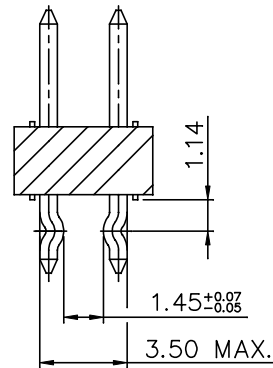

SECTION : A-A
TYPE 2: WITH KINKS

X.±	X°. ± 2°	UNITS mm	NAME(INTENDED USE) HEADER CONN.	FOXCONN FOXCONN INTERCONNECT TECHNOLOGY LIMITED.
.X± 0.25	.X°±	MAT'L	PART NO.(INTENDED USE) HC01/08/11/ 12/13 SERIES	
.XX± 0.13	.XX°±	FINISH	APPD: Shih-Wei Hsiao	CLASS: <input type="checkbox"/> CONFIDENTIAL <input type="checkbox"/> SECRET <input checked="" type="checkbox"/> GENERAL
.XXX±	.XXX°±		Q'TY	CHKD: Yen-Chi.Chang
THESE DRAWINGS AND SPECIFICATIONS ARE THE PROPERTY OF FOXCONN INTERCONNECT TECHNOLOGY LIMITED. AND SHALL NOT BE REPRODUCED, COPIED OR USED IN ANY MANNER WITHOUT THE PRIOR WRITTEN CONSENT OF FOXCONN INTERCONNECT TECHNOLOGY LIMITED.			DR: Xu Liu 06/22'17	DWG NO.: 307-0000-214

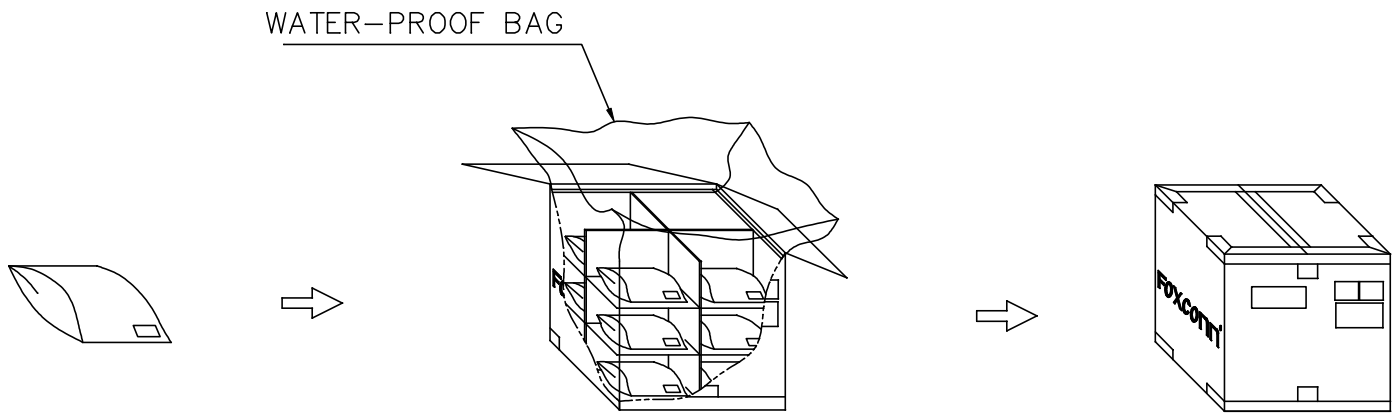

ITEM	DESC.	Q'TY	MATERIAL	TREATMENT	REMARK
①	CONTACT	SAME AS No. OF POS. (SEE BELOW)	BRASS	A) 50u" MIN. NICKEL UNDER PLATING OVER ALL B) 100u" MIN. MATTE TIN OR GOLD PLATING ON TAIL AREA C) 100u" MIN. MATTE TIN OR GOLD PLATING ON CONTACT AREA (SEE NOTES BELOW)	
②	HOUSING	1	PA66, UL 94V-0	HOUSING COLOR SEE DRAWING "307-0000-209"	

NOTES :

- HARMFUL MATERIAL CONTROL PLEASE FOLLOW FOXCONN'S DOC. "EPI12".
- PLEASE CONTACT FOXCONN SALES REPRESENTATIVE TO VERIFY PRODUCT DETAILS & AVAILABILITY.
- PRODUCT No. MATRIX:

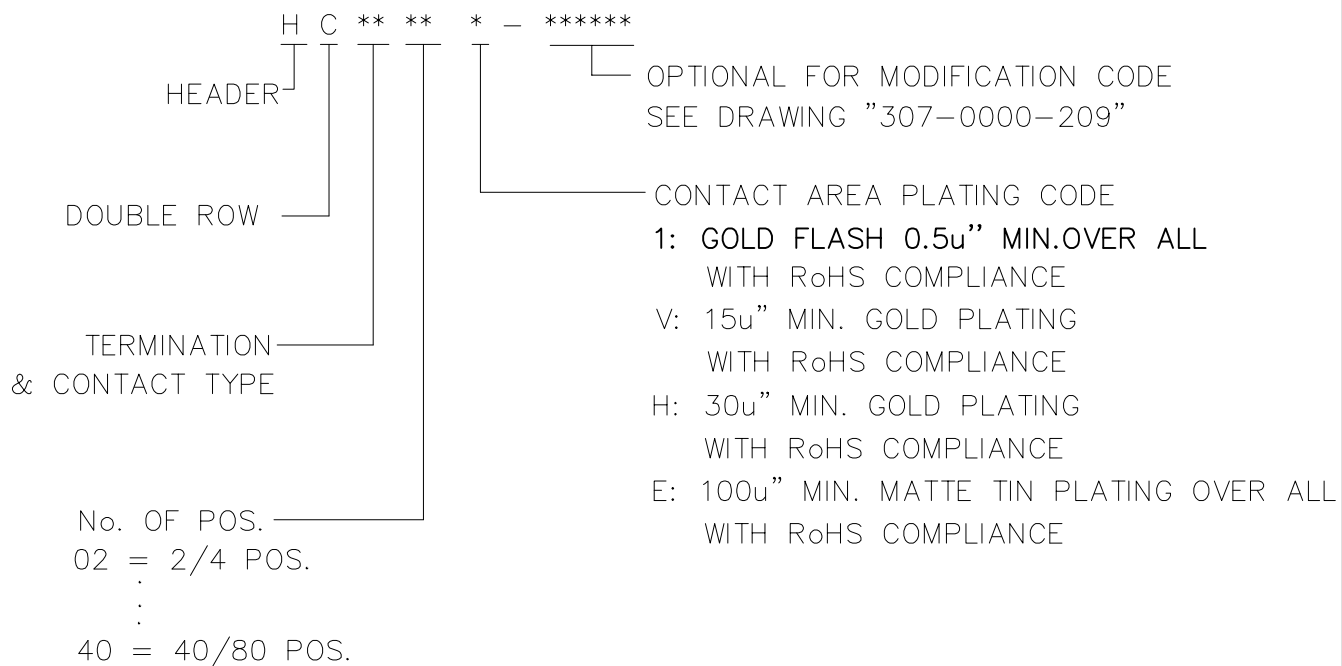

FOXCONN HON HAI PRECISION IND. CO.,LTD.
TAIPEI, TAIWAN, R.O.C.

APPD. : Shih-Wei Hsaio	TITLE : MATERIAL SHEET
CHKD. : Yusan Hsaio	PROD. SERIES : HC01/08/11/ 12/13 SERIES
DR. : Xu Liu 04/25'14	DWG. NO : 307-0500-214
	REV. : B SHEET : 1/1

B	BC-14-0020789	Shih-Wei Hsaio
A	BC-07-7036382	Yusan
REV.	ECN. NO.	APPD.

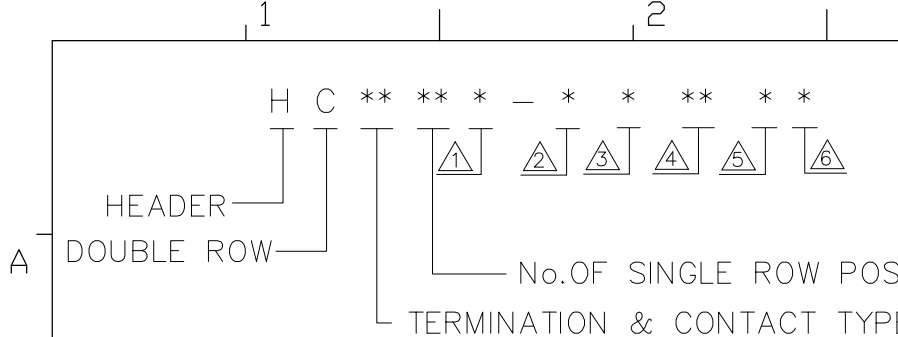

REMARK:

△ PLATING SPEC OPTION

1: GOLD FLASH OVER ALL

U: GOLD FLASH ON CONTACT AREA

100u" MIN. MATTE TIN PLATING ON TAIL
WITH RoHS COMPLIANCE

E: 100u" MIN. MATTE TIN PLATING OVER ALL
WITH RoHS COMPLIANCE

H: 30u" MIN. GOLD ON PLATING CONTACT AREA
100u" MIN. MATTE TIN PLATING ON TAIL
WITH RoHS COMPLIANCE

V: 15u" MIN. GOLD PLATING ON CONTACT AREA
100u" MIN. MATTE TIN PLATING ON TAIL
WITH RoHS COMPLIANCE

F: GOLD FLASH VOER ALL
WITH RoHS COMPLIANCE FOR LOOSE PIN
OR GOLD FLASH ON CONTACT AREA
100u" MIN. MATTE TIN PLATING ON TAIL
WITH RoHS COMPLIANCE FOR BANDOLIER PIN.

REV	ECN. NO.	APPD.
A	HC95574	Jeff 4/14'95
B	HC951422	I.K.Liu 10/3'95
C	HC951537	I.K.Liu 10/30'95
D	HC951580	Jeff 11/7'95
E	HC96025	I.K.Liu 1/6'96
F	HC96196	C. CHEN 2/7'06
G	HC96583	I.K.Liu 4/20'96
H	HC961175	C. CHEN 8/14'96
J	HC97580	C. CHEN 3/30'97
K	HC972839	Charles 12/8'97
L	HC98393	I.K.Liu 2/20'98
M	HC990707	DiCl Lee 3/17'99
N	HC991364	DiCl Lee 7/17'99
P	MC002571	Y.K.Liu 8/23'00
Q	IC014668	Yihsin Chen 11/3'01
R	IC021003	Yihsin Chen 3/27'02
S	IC023145	Yihsin Chen 5/6'02
T	IC0214775	Lvan lai 3/11'03
U	BC0361580	Michael Lai 5/17'03
V	BC0379340	Yihsin Chen 10/14'03
W	BC0384697	Yihsin Chen 11/24'03
Y	HC0412051	Ady Zhou 1/10'05
Z	HC051090	Ady Zhou 2/18'05
A1	BC-06-773080	Jake W.Y
A2	BC-07-7057891	Yusan
A3	BC-07-7088490	Jake W.Y
A4	BC-08-7036412	Jake W.Y
A5	BC-08-7136479	Jake W.Y
A6	BC-11-0103815	Yihsin Chen
A7	BC-14-0020609	Shih-Wei Hsiao

X.±	X°±	UNITS mm	NAME(INTENDED USE)	FOXCONN			
.X±	.X°±	MAT'L	BREAKAWAY HEADER	HON HAI PRECISION IND. CO.,LTD. TAIPEI, TAIWAN, R.O.C.			
.XX±	.XX°±		PART NO.(INTENDED USE)	TITLE: TABLE, MODIFICATION CODE			
.XXX±	.XXX°±	FINISH	HC SERIES	DWG NO.: 307-0000-209			
THESE DRAWINGS AND SPECIFICATIONS ARE THE PROPERTY OF HON HAI PRECISION IND. CO., LTD. AND SHALL NOT BE REPRODUCED, COPIED OR USED IN ANY MANNER WITHOUT THE PRIOR WRITTEN CONSENT OF HON HAI PRECISION IND. CO., LTD.			Q'TY	APPD: Shih-Wei Hsiao		SCALE	SHEET
		CHKD: Yusan Hsiao		N/A		1/5	A7
		DR: Xu Liu 04/24'14					

3	4
REV.	ECN. NO.
	APPD.

△ KINK OPTION

NONE/1: WITHOUT KINKS

K: WITH KINKS.

A) POS. 1/2, 3/6, 5/10

K = THE MID. PAIR OF TERMINALS
IS KINKED.

B) POS. 2/4, 4/8, 6/12

K = THE PRECEDING PAIR OF TERMINALS
IN MID. IS KINKED.

C) POS. 7/14~40/80

K = THE 2ND PAIR FROM THE TOP AND
THE 2ND PAIR FROM THE END TWO
PAIRS OF TERMINALS ARE KINKED.

D) FOR REMOVED PIN(S), KINK POSITION(S)

SHOULD BE CHANGED TO THE NEXT PAIR.

△ HOUSING COLOR OPTION

NONE/1 : STANDARD PRODUCT, COLOR BLACK.

U: BLUE COLOR (PANTON 661C).

W: IVORY COLOR.

Y: YELLOW COLOR (PANTONE 123C).

R: RED COLOR (PANTONE 032C).

J: ORANGE COLOR (PANTONE 1665C).

G: GREEN COLOR (PANTONE 347C).

T: ORANGE COLOR (PANTONE 157C).

Q: RHODAMINE RED (233C).

B: DARK BLUE (2935C).

L: LIGHT GRAY COLOR (7541C)

E: BURGUNDY COLOR(PANTONE 235C).

N: BLUE COLOR (PANTONE 660C).

S: PURPLE COLOR (PANTONE 2715C).

F: WHITE COLOR

E	X.±	X°±	UNITS mm	NAME(INTENDED USE)	FOXCONN HON HAI PRECISION IND. CO.,LTD. TAIPEI, TAIWAN, R.O.C.						
	.X±	.X°±	MAT'L	BREAKAWAY HEADER							
	.XX±	.XX°±	FINISH	PART NO.(INTENDED USE)	TITLE:						
	.XXX±	.XXX°±		HC SERIES	TABLE, MODIFICATION CODE						
	THESE DRAWINGS AND SPECIFICATIONS ARE THE PROPERTY OF HON HAI PRECISION IND. CO., LTD. AND SHALL NOT BE REPRODUCED. COPIED OR USED IN ANY MANNER WITHOUT THE PRIOR WRITTEN CONSENT OF HON HAI PRECISION IND. CO., LTD.			Q'TY	APPD: Shih-Wei Hsiao	DWG NO.: 307-0000-209					
			CHKD: Yusan Hsiao	DR: Xu Liu 04/24'14	 <table border="1"> <tr> <td>SCALE</td> <td>SHEET</td> <td>REV.</td> </tr> <tr> <td>N/A</td> <td>2/5</td> <td>A7</td> </tr> </table>	SCALE	SHEET	REV.	N/A	2/5	A7
SCALE	SHEET	REV.									
N/A	2/5	A7									

REV.	ECN. NO.	APPD.

Z: GREEN COLOR (PANTONE 7487C).
A: RED COLOR (PANTONE 177C).
M: LIGHT BLUE COLOR (PANTONE 298C).
H: ORANGE COLOR (PANTONE 151C).
D: CHARCOAL COLOR (7547C)
P: CAFE COLOR (168C)
C: BLUE COLOR(PANTONE 298C).
V: LIGHT GREEN COLOR(PANTONE 358C).

△ REMOVED PIN CODE.

CODE	DESCRIPTION
NONE/00	FULL PIN
D0	1st PIN OMITTED.
D1	2nd & FINAL 2nd PINS OMITTED.
D2	20th POSITION OMITTED.
D3	21st POSITION OMITTED.
D4	8th POSITION OMITTED.
D5	3rd POSITION OMITTED.
D6	25th POSITION OMITTED.
D7	5th, 6th & 16th POSITION OMITTED.
D8	3rd & 8th POSITION OMITTED.
D9	3rd, 4th & 14th POSITION OMITTED.
P0	4th POSITION OMITTED.
P1	6th POSITION OMITTED.
P2	9th & 10th POSITION OMITTED.
P3	2nd POSITION OMITTED.
P4	5th POSITION OMITTED.
P5	10th POSITION OMITTED.
P6	11th POSITION OMITTED.
P7	29th POSITION OMITTED.
P8	7th POSITION OMITTED.
P9	9th POSITION OMITTED.
G0	3th & 6th POSITION OMITTED.
G1	24th POSITION OMITTED.
G2	10th,11th,12th,13th,15th,17th,19th POSITION OMITTED.
G3	7th POSITION OMITTED.
G4	4th,5th,7th,8th,9th,10th,12th,15th POSITION OMITTED.
G5	19th POSITION OMITTED.
G7	9th & 14th POSITION OMITTED.
G8	4th & 21th & 22th POSITION OMITTED.
G9	3th & 4th & 5th & 6th POSITION OMITTED.
A0	9th POSITION OMITTED&10POSITION MATING END OMITTED.
A1	2th & 6th POSITION OMITTED.
A2	4th & 15TH & 16TH POSITION OMITTED
A3	10th & 12TH & 13TH POSITION OMITTED
A4	10th & 11th &12th POSITION OMITTED

X.±	X°.±	UNITS mm	NAME(INTENDED USE)	FOXCONN		
.X±	.X°.±	MAT'L	BREAKAWAY HEADER	HON HAI PRECISION IND. CO.,LTD. TAIPEI, TAIWAN, R.O.C.		
.XX±	.XX°.±	FINISH	PART NO.(INTENDED USE)	TITLE:		
.XXX±	.XXX°.±		HC SERIES	TABLE, MODIFICATION CODE		
THESE DRAWINGS AND SPECIFICATIONS ARE THE PROPERTY OF HON HAI PRECISION IND. CO., LTD. AND SHALL NOT BE REPRODUCED, COPIED OR USED IN ANY MANNER WITHOUT THE PRIOR WRITTEN CONSENT OF HON HAI PRECISION IND. CO., LTD.		Q'TY	APPD: Shih-Wei Hsiao	DWG NO.:		
			CHKD: Yusan Hsiao	307-0000-209		
			DR: Xu Liu 04/24'14		SCALE	SHEET
				N/A	3/5	A7

REV.	ECN. NO.	APPD.

T0	1st&3rd&4th&5th&6th&7th&8th POSTION OMITTED.
T1	1st & END PINS WITH KINK, 2nd POSTION OMITTED.
T2	ALL PINS WITH KINK, 3rd & 4th POSITION OMITTED.
T3	ALL PINS WITH KINK, 5th & 6th POSITION OMITTED.
T4	5th, 18th POSITION OMITTED.
T5	30th POSITION OMITTED.
T6	2nd, 11th, 12th & 28th POSITION OMITTED.
T7	8th & 16th POSITION OMITTED.
T8	2nd & 3rd POSITION OMITTED.
T9	2nd & 14th POSITION OMITTED.

L0	2nd, 7th & 17th POSITION OMITTED.
L1	12th POSITION OMITTED.
L2	4th,14th & 19th POSITION OMITTED.
L3	4th & 7th POSITION OMITTED
L4	7th, 8th & 18th POSITION OMITTED.
L5	18th POSITION OMITTED.
L6	14th POSITION OMITTED.
L7	5th & 6th POSITION OMITTED.
L8	2nd & 4th POSITION OMITTED.
L9	11th, 17th, 18th & 19th POSITION OMITTED.

CODE	DESCRIPTION
U0	13th & 14th POSITION OMITTED.
U1	3rd & 5th POSITION OMITTED
U2	17th POSITION OMITTED.
U3	10th POSITION AND 14th POSITION OMITTED.
U4	13th POSITION OMITTED.
U5	6th, 7th & 10th POSITION OMITTED.
U6	1st & 24th POSITION OMITTED.
U7	16th, 17th, 18th & 24th POSITION OMITTED.
U8	3rd, 4th, 29th & 32nd POSITION OMITTED.
U9	11th & 18th POSITION OMITTED.

E0	3rd, 25th & 26th POSITION OMITTED.
E1	7th, 8th & 10th POSITION OMITTED.
E2	7th & 8th POSITION OMITTED.
E3	7th, 8th, 15th, 16th, 23rd & 24th POS. OMITTED.
E4	13th, 14th & 15th POSITION OMITTED.
E5	27th POSITION OMITTED.
E6	1st, 11th, 12th & 15th POS. OMITTED.
E7	7th, 8th, 15th & 16th POS. OMITTED.
E8	1st & 5th POSITION OMITTED.
E9	13th, 14th & 16th POS. OMITTED.

X.±	X°±	UNITS mm	NAME(INTENDED USE)	FOXCONN HON HAI PRECISION IND. CO.,LTD. TAIPEI, TAIWAN, R.O.C.				
.X±	.X°±	MAT'L	BREAKAWAY HEADER					
.XX±	.XX°±	FINISH	PART NO.(INTENDED USE)	TITLE:				
.XXX±	.XXX°±		HC SERIES	TABLE, MODIFICATION CODE				
THESE DRAWINGS AND SPECIFICATIONS ARE THE PROPERTY OF HON HAI PRECISION IND. CO., LTD. AND SHALL NOT BE REPRODUCED. COPIED OR USED IN ANY MANNER WITHOUT THE PRIOR WRITTEN CONSENT OF HON HAI PRECISION IND. CO., LTD.			APPD: Shih-Wei Hsiao	DWG NO.: 307-0000-209				
			Q'TY	CHKD: Yusan Hsiao		SCALE	SHEET	REV.
			DR: Xu Liu 04/24'14			N/A	4/5	A7

REV.	ECN. NO.	APPD.

B0	3rd, 4th, 17th, 19th & 20th POSITION OMITTED.
B1	3th & 10th POSITION OMITTED.
B2	6th & 12th POSITION OMITTED.
B3	26th POSITION OMITTED.
B4	3rd, 25th & 26th POSITION OMITTED.
B5	5th & 13th POSITION OMITTED.
B6	1st & 11th POSITION OMITTED.
B7	15th POSITION OMITTED.
B8	3rd, 14th, 16th, & 23th POSITION OMITTED.
B9	5th, 9th, & 10th POSITION OMITTED.

F0	13th & 15TH POSITION OMITTED
F1	22th POSITION OMITTED
F2	13th , 15th & 16th POSITION OMITTED
F3	3rd & 9th POSITION OMITTED
F4	3rd,4th&13th POSITION OMITTED
F5	10th&15th POSITION OMITTED
F6	17th&18th POSITION OMITTED
F7	3rd,4th&13th POSITION OMITTED
F8	3rd&6th POSITION OMITTED
F9	3rd&4th POSITION OMITTED

△ MATERIAL OPTION
 NONE/1: HALOGEN MATERIAL
 B: THERMOPLASTIC
 HALOGEN FREE MATERIAL
 L: HIGH TEMPERATURE
 HALOGEN FREE MATERIAL

△ ROHS CODE
 NONE/F: ROHS PRODUCT
 H: ROHS&, HALOGEN FREE

- HARMFUL MATERIAL CONTROL PLEASE FOLLOW FOXCONN'S DOC. "EPI12".
- PLEASE CONTACT FOXCONN SALES REPRESENTATIVE TO VERIFY PRODUCT DETAILS & AVAILABILITY.

	X°±	UNITS mm	NAME(INTENDED USE)	FOXCONN			
	.X°±	MAT'L	BREAKAWAY HEADER	HON HAI PRECISION IND. CO.,LTD. TAIPEI, TAIWAN, R.O.C.			
	.XX°±		PART NO.(INTENDED USE)	TITLE:			
	.XXX°±	FINISH	HC SERIES	TABLE, MODIFICATION CODE			
THESE DRAWINGS AND SPECIFICATIONS ARE THE PROPERTY OF HON HAI PRECISION IND. CO., LTD. AND SHALL NOT BE REPRODUCED. COPIED OR USED IN ANY MANNER WITHOUT THE PRIOR WRITTEN CONSENT OF HON HAI PRECISION IND. CO., LTD.			Q'TY	APPD: Shih-Wei Hsiao	DWG NO.: 307-0000-209		
			CHKD: Yusan Hsiao		SCALE	SHEET	REV.
			DR: Xu Liu 04/24'14		N/A	5/5	A7

SPECIFICATIONS:

1. MATERIAL AND FINISH:

1-1. HOUSING:

THERMOPLASTIC PA66, UL 94V-0 RATING.

1-2. CONTACT:

COPPER ALLOY, 50u" MIN. NICKEL UNDER PLATING,
100u" MIN. MATTE TIN OR GOLD PLATING OVER NICKEL.

2. ELECTRICAL CHARACTERISTICS:

2-1. CONTACT CURRENT RATING: 3 AMPERES MAX. PER CONTACT.

2-2. DIELECTRIC WITHSTANDING VOLTAGE: 500V AC FOR 1 MINUTE
AT SEA LEVEL.

2-3. INSULATION RESISTANCE: 1000 MEGOHMS MIN. INITIAL.

3. MECHANICAL CHARACTERISTICS:

3-1. CONTACT RETENTION FORCE: 2LBS(0.91 Kg) MIN. PER CONTACT.

3-2. CONTACT INSERTION FORCE : 0.50kg MAX. PER PIN

3-3. CONTACT WITHDRAWAL FORCE : 0.05kg MIN. PER PIN

4. ENVIRONMENTAL DATA:

4-1. SOLDERABILITY: PASSED EIA-364-52.

4-2. OPERATION TEMPERATURE: -40°C TO +105°C .

4-3. HARMFUL MATERIAL CONTROL PLEASE FOLLOW
FOXCONN'S DOC. "EPI12".

5. PLEASE CONTACT FOXCONN SALES REPRESENTATIVE TO VERIFY
PRODUCT DETAIL & AVAILABILITY.

F	BC-14-0020785	Shih-Wei Hsiao
E	BC-08-7036716	Jake W.Y
D	BC-07-702881	Yusan
C	BC-06-741986	Yusan 7/28'06
B	IC025862	Yihsin Chen 8/10'02
A	MC991901	Y.K.Liu 8/6'99
REV.	ECN NO.	APPD.

FOXCONN HON HAI PRECISION IND. CO.,LTD. TAIPEI, TAIWAN, R.O.C.	
APPD. : Shih-Wei Hsiao	TITLE : SPECIFICATION
CHKD. : Yusan Hsiao	PROD. SERIES : HC01/08/11/ 12/13 SERIES
DR. : Xu Liu 04/25'14	DWG. NO : 307-0300-214
	REV. : F SHEET : 1/1

X-ON Electronics

Largest Supplier of Electrical and Electronic Components

Click to view similar products for [Headers & Wire Housings](#) category:

Click to view products by [Foxconn](#) manufacturer:

Other Similar products are found below :

[0015917161](#) [0022155065](#) [57102-F02-18ULF](#) [58102-G61-06LF](#) [582553-1](#) [01.001.5753.1](#) [0050291907](#) [02.125.8002.8](#) [609-3404](#) [61062-3](#)
[CSU011177004](#) [622-0430](#) [622-3653LF](#) [63453-116](#) [636-1030](#) [636-1427](#) [636-3427](#) [636-4007](#) [641938-9](#) [65495-038](#) [65692-001LF](#) [65781-018](#)
[65781-047](#) [65817-010LF](#) [65817-015LF](#) [67095-007LF](#) [67601157](#) [68631-112](#) [68645-018](#) [699319-000](#) [70.362.1628.0](#) [70-4210](#) [70-4226B](#) [70-](#)
[4853B](#) [71.350.2428.0](#) [733-134](#) [733-162](#) [MHR-64-VUAL](#) [80.063.4001.1](#) [800-90-001-10-001000](#) [801-43-002-10-013000](#) [801-43-006-10-](#)
[002000](#) [803-43-024-10-001000](#) [803-93-012-10-001000](#) [8-1437020-4](#) [819-22-004-30-001101](#) [820-22-006-30-001101](#) [820-22-008-30-001101](#)
[821-22-002-10-001101](#) [821-22-003-10-002101](#)