

HFBR-5911LZ/ALZ

Small Form Factor Optical Transceiver for Gigabit Ethernet (1.25 Gbd) and iSCSI



Data Sheet



Description

The HFBR-5911LZ/ALZ optical transceiver from Avago Technologies is designed for use in short-reach multi-mode fiber optic (1000BASE-SX) links between Gigabit Ethernet networking equipment. Interoperable with all equipment meeting the Gigabit Ethernet industry standard, it is compliant with the Small Form Factor Multi Source Agreement and requires a 3.3 V dc power supply. The electrical interface follows the 2 x 5 format while the optical interface uses the LC-Duplex connector.

Related Products

- AFBR-5710LZ: 850 nm Small Form Factor Pluggable optical transceiver for short reach Gigabit Ethernet (1000BASE-SX) links
- HDMP-1687: Quad SerDes IC for Gigabit Ethernet with 10 bit parallel interface and TTL clock input
- HDMP-1685A: Quad SerDes IC for Gigabit Ethernet with 5 bit parallel interface and DDR TTL clock input
- HDMP-1636A/46A: Single SerDes IC for Gigabit Ethernet and Fiber Channel
- HDMP-1637A: Single SerDes IC with PECL RefClk
- HDMP-1638: Single SerDes IC with PECL RefClk and Dual Serial I/O
- HDMP-2634: Single SerDes IC 2.5/1.25 Gigabit

Features

- IEEE 802.3 Gigabit Ethernet (1.25 Gbd) 1000BASE-SX compliant
- Industry standard small form factor (SFF) package
- LC-duplex connector optical interface
- 850 nm Vertical cavity surface emitting laser
- Internally terminated and ac coupled data IO
- Extended operating temperature range (HFBR-5911ALZ only) :
-10 to +85 °C
- Signal detect TTL
- Maximum link lengths:
62.5/125 μ m fiber 275 m
50/125 μ m fiber 550 m
- Laser AEL Class 1 (eye safe) per:
 - US 21 CFR(J)
 - EN 60825-1 (+All)
- +3.3 V dc power supply
- Manufactured in ISO 9001 facilities
- RoHS Compliant

Applications

- Short-reach Gigabit Ethernet links
- High speed backplane interconnects
- Switched backbones
- iSCSI applications

Overview

Avago Technologies' HFBR-5911LZ/ALZ optical transceiver supports high-speed serial links over multimode optical fiber at signaling rates of up to 1.25 Gb/s. Compliant with the Small Form Factor (SFF) Multi Source Agreement (MSA) for 2 x 5 pin LC Duplex transceivers and IEEE 802.3 specification for Gigabit Ethernet (GbE) links (1000BASE-SX), the part is interoperable and interchangeable with other conformant devices. Supported Gigabit Ethernet link lengths are described in Table 1, but the transceiver can also be used for other high-speed serial applications, such as iSCSI.

The SFF package of the HFBR-5911LZ/ALZ allows designers of Gigabit Ethernet networking equipment to maximize their use of available board space. The footprint of the HFBR-5911LZ/ALZ is significantly smaller than those of other GbE transceivers formats - 25% smaller than SFP cage assemblies, 30% smaller than traditional 1 x 9 transceivers and 70% smaller than GBIC rail assemblies. The HFBR-5911LZ/ALZ trace keep-out area is less than 10% as large as that required by SFP transceivers. For applications not requiring hot-pluggability, the HFBR-5911LZ/ALZ offers a more space-efficient package without the additional cost and complexity imposed by pluggable architecture.

Module Diagrams

The major functional components of the HFBR-5911LZ/ALZ are illustrated in Figure 2 page 9. The external configuration of the transceiver is depicted in Figure 3 page 10 while the host board and front panel layouts defined by the SFF MSA are shown in Figure 4, page 11.

Transmitter Section

The transmitter section consists of the Transmitter Optical Subassembly (TOSA) and laser driver circuitry. The TOSA, containing an 850 nm VCSEL (Vertical Cavity Surface Emitting Laser) light source, is located at the optical interface and mates with the LC optical connector. The TOSA is driven by a custom IC which uses the incoming differential PECL logic signals to modulate the laser diode drive current. This Tx laser driver circuit regulates the optical output power at a constant level provided that the incoming data pattern is dc balanced (8B10B code for example).

Tx_Disable

The HFBR-5911LZ/ALZ accepts a TTL transmit disable control signal input which shuts down the transmitter. A high signal implements this function while a low signal allows normal transceiver operation. In the event of a fault (e.g., eye safety circuit activated), cycling this control signal resets the module as depicted in Figure 5 page 12. A pull-down resistor enables the laser if the line is not connected on the host board.

Host systems should allow a 10 ms interval between successive assertions of this control signal.

Eye Safety Circuit

The HFBR-5911LZ/ALZ provides Class 1 eye safety by design and has been tested for compliance with the requirements listed in Table 11. The eye safety circuit continuously monitors optical output power levels and will disable the transmitter upon detecting an unsafe condition. Such unsafe conditions can be due to inputs from the host board (V_{CC} fluctuation, unbalanced code) or faults within the transceiver.

Receiver Section

The receiver section includes the Receiver Optical Subassembly (ROSA) and the amplification/quantization circuitry. The ROSA, containing a PIN photodiode and custom transimpedance preamplifier, is located at the optical interface and mates with the LC optical connector. The ROSA output is fed to a custom IC that provides post-amplification and quantization.

Signal Detect

The post-amplification/quantizer IC also includes transition detection circuitry that monitors the ac level of the incoming optical signal and provides a TTL status signal to the host. An adequate optical input results in a high output while a low Signal Detect output indicates an unusable optical input. The Signal Detect thresholds are set so that a low output indicates a definite optical fault has occurred (e.g., disconnected or broken fiber connection to receiver, failed transmitter, etc.).

Electrical Interfaces

The HFBR-5911LZ/ALZ interfaces with the host circuit board through the ten I/O pins identified by function in Table 4. These pins are sized for use in boards between 0.062 in. and 0.100 in. thick. The board layout for this interface is depicted in Figure 4.

The HFBR-5911LZ/ALZ transmit and receive interfaces require PECL differential signal lines on the host board. To simplify board requirements, transmitter bias resistors and ac coupling capacitors are incorporated into the transceiver module and so are not required on the host board.

The Tx_Disable and Signal Detect lines require TTL lines on the host board if they are to be utilized. The transceiver will operate normally if these lines are not connected on the host board.

Figure 2 depicts a recommended interface circuit to link the HFBR-5911LZ/ALZ to the supporting physical layer ICs.

Timing for the MSA compliant control signals implemented in this transceiver are listed in Table 9 and diagramed in Figure 5.

PCB Assembly Process Compatibility

The HFBR-5911LZ/ALZ is compatible with industry-standard wave solder and aqueous wash processes as detailed in Table 10. The transceiver is shipped with a process plug to keep out impinging liquids, but is not intended to be immersed. After assembly, the process plug should be kept in place as a dust plug when the transceiver is not in use.

Regulatory Compliance

The HFBR-5911LZ/ALZ complies with all applicable laws and regulations as detailed in Table 11. Certification level is dependent of the overall configuration of the host equipment. The transceiver performance is offered as a figure of merit to assist the designer.

Electrostatic Discharge (ESD)

The HFBR-5911LZ/ALZ is compatible with ESD levels found in typical manufacturing and operating environments as described in Table 11. In the normal handling and operation of optical transceivers, ESD is of concern in two circumstances.

The first case is during handling of the transceiver prior to soldering onto the host board. To protect the device, it's important to use normal ESD handling precautions. These include using grounded wrist straps, workbenches and floor mats wherever the transceiver is handled.

The second case to consider is static discharges to the exterior of the host equipment chassis after assembly. If the optical interface is exposed to the exterior of the host equipment cabinet, the transceiver may be subject to system-level ESD requirements.

EMI Immunity

Due to its shielded design, the EMI immunity of the HFBR-5911LZ/ALZ exceeds typical industry standards.

Electromagnetic Interference (EMI)

Equipment incorporating Gigabit transceivers is typically subject to regulation by the FCC in the United States, TUV in the European Union and VCCI in Japan. The HFBR-5911LZ/ALZ's compliance to these standards is detailed in Table 11.

The metal housing and shielded design of the HFBR-5911LZ/ALZ minimize the EMI challenge facing the equipment designer.

Flammability

The HFBR-5911LZ/ALZ optical transceiver is made of metal and high strength, heat resistant, chemical resistant and UL 94V-0 flame retardant plastic.

Caution

There are no user serviceable parts nor any maintenance required for the HFBR-5911LZ/ALZ. All adjustments are made at the factory before shipment. Tampering with, modifying, misusing or improperly handling the HFBR-5911LZ/ALZ will void the product warranty. It may also result in improper operation and possibly overstress the laser source. Performance degradation or device failure may result. Connection of the HFBR-5911LZ/ALZ to a light source not compliant to the Gigabit Ethernet specification (IEEE 802.3), operating above the recommended absolute maximum operating conditions or in a manner inconsistent with it's design and function may result in exposure to hazardous radiation and may constitute an act of modifying or manufacturing a laser product. Person's performing such an act are required by law to recertify and re-identify the laser product under the provisions of U.S. 21 CFR (Subchapter J).

Table 1 - Supported Links from IEEE 802.3

Fiber Type	Modal bandwidth @ 850 nm (min. overfilled launch) (MHz - km)	Link length		Units
		Minimum	Maximum	
62.5 μ m MMF	160	2	220	m
62.5 μ m MMF	200	2	275	m
50 μ m MMF	400	2	500	m
50 μ m MMF	500	2	550	m

Table 2 - Absolute Maximum Ratings

The Absolute Maximum Ratings are those values beyond which damage to the device may occur if these limits are exceeded for other than a short period of time. See Reliability Data Sheet for specific reliability performance.

Parameter	Symbol	Minimum	Typical	Maximum	Units	Reference
Storage Temperature	T _S	-40		+100	°C	
Operating Temperature - Case	T _C	-10		+85	°C	
Aqueous Wash Pressure				110	psi	
Relative Humidity - non condensing	RH	5		95	%	
Supply Voltage	V _{CC}	-0.5		3.63	V	
Voltage to any pin		-0.5		3.63	V	
TTL Transmit Disable Current	I _I	-3.0		3.0	mA	

Table 3 - Recommended Operating Conditions

The Recommended Operating Conditions are those values outside of which device reliability and performance to data sheet are not implied, and damage to the device may occur over an extended period of time. See Reliability Data Sheet for specific reliability performance.

Parameter	Symbol	Minimum	Typical	Maximum	Units	Reference
Temperature - Case						
HFBR-5911LZ	T _C	0		+70	°C	11
HFBR-5911ALZ	T _C	-10		+85	°C	
Supply Voltage	V _{CC}	3.14		3.47	V	
Input Data Differential Voltage		0.4		1.6	V	
TTL Transmit Disable Input Voltage - Low	V _{IL}			0.8	V	
TTL Transmit Disable Input Voltage - High	V _{IH}	V _{CC} -1.3		V _{CC}	V	
TTL Transmit Disable Input Current	I _I	-1.0		400	mA	

Notes:

1. Operating the transceiver beyond +70 °C for extended periods can adversely affect device reliability.

Table 4 - Pin Description

Pin	Symbol	Functional Description	Logic	Reference
MS	MS	Mounting Stud	n/a	4
HL	HL	Housing Lead	n/a	5
1	Vee _r	Receiver Signal Ground	n/a	
2	Vcc _r	Receiver Power Supply	n/a	
3	SD	Signal Detect	TTL	6
4	RD-	Receiver Data Out Bar	PECL	7
5	RD+	Receiver Data Out	PECL	7
MS	MS	Mounting Stud	n/a	4
HL	HL	Housing Lead	n/a	5
6	Vcc _t	Transmitter Power Supply	n/a	
7	Vee _t	Transmitter Signal Ground	n/a	
8	T _{Dis}	Transmitter Disable	TTL	8
9	TD+	Transmitter Data In	PECL	9
10	TD-	Transmitter Data In Bar	PECL	9

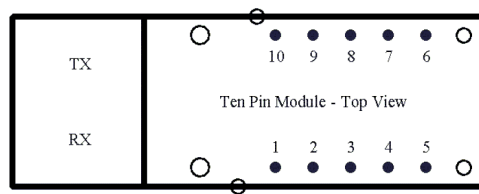

Figure 1 - Pin out drawing

Table 5 - Transmitter Electrical Characteristics

HFBR-5911LZ (T_C = 0°C to +70°C, V_{CC} = 3.14 V to 3.47 V)

HFBR-5911ALZ (T_C = -10 °C to +85 °C, V_{CC} = 3.14 V to 3.47 V)

Parameter	Symbol	Minimum	Typical	Maximum	Units	Reference
Transmitter Supply Current	I _{CC} Tx		55	75	mA	
Power Dissipation	P _{DISS}		180	260	mW	
Data Input Differential Voltage	V _{IH} -V _{IL}	400		1600	mV	
Power Supply Noise Rejection	PSNR		100		mV _{P-P}	10

Notes:

- The mounting studs provide mechanical attachment to the circuit board and connection to the equipment chassis ground. The MS via holes must not be tied to signal ground and may be tied to chassis ground.
- The housing leads provide additional signal grounding. The HL via holes must be tied to signal ground.
- Normal operation: Logic "1" output
No-signal condition: Logic "0" output
- AC coupled differential output. LVPECL signal. Interfacing ICs may require internal biasing.
- Transmitter Output Disabled: (V_{CCt}-1.3 V)<V<V_{CCt}
Transmitter Output Enabled: Vee_t < V < (Vee_t +0.8 V)
- AC coupled differential input, no external termination required. 100 ohm internal termination provided.
- Tested with a 100 mV_{P-P} sinusoidal signal in the frequency range from 10 KHz to 2 MHz on the V_{CC} supply with the recommended power supply filter (with C8) in place. Typically, a change in sensitivity of less than 1 dB is experienced.

Table 6 - Transmitter Optical CharacteristicsHFBR-5911LZ ($T_C = 0^\circ\text{C}$ to $+70^\circ\text{C}$, $V_{CC} = 3.14\text{ V}$ to 3.47 V)HFBR-5911ALZ ($T_C = -10^\circ\text{C}$ to $+85^\circ\text{C}$, $V_{CC} = 3.14\text{ V}$ to 3.47 V)

Parameter	Symbol	Minimum	Typical	Maximum	Units	Reference
Optical Output Power						
62.5 μm	P_{OUT}	-9.5		-1.5	dBm avg.	11
50 μm		-9.5		-1.5		
Tx_Disable Optical Output Power	$P_{OUT\ DIS}$			-30	dBm avg.	11
Optical Extinction Ratio	ER	9			dB	12
Center Wavelength	λ_C	830	850	860	nm	
Spectral Width - rms	σ			0.85	nm rms	
Optical Rise Time	t_r			0.26	ns	13
Optical Fall Time	t_f			0.26	ns	13
RIN_{12}				-117	dB/Hz	
Coupled Power Ratio	CPR	9			dB	14
Contributed Total Jitter	TJ			2270.284	psUI	15

Table 7 - Receiver Electrical CharacteristicsHFBR-5911LZ ($T_C = 0^\circ\text{C}$ to $+70^\circ\text{C}$, $V_{CC} = 3.14\text{ V}$ to 3.47 V)HFBR-5911ALZ ($T_C = -10^\circ\text{C}$ to $+85^\circ\text{C}$, $V_{CC} = 3.14\text{ V}$ to 3.47 V)

Parameter	Symbol	Minimum	Typical	Maximum	Units	Reference
Receiver Supply Current	I_{CCRX}			135	mA	
Power Dissipation	P_{DISS}		230	470	mW	
Power Supply Noise Rejection	PSNR		100		mV _{p-p}	16
Data Output Differential Voltage	$V_{OH}-V_{OL}$	0.4		1.3	V	
Data Output Rise Time	t_r			0.4	ns	
Data Output Fall Time	t_f			0.4	ns	
TTL Signal Detect Output Voltage - Low	V_{OL}			0.6	V	
TTL Signal Detect Output Voltage - High	V_{OH}	2.2			V	

Notes:

- The maximum Optical Output Power complies with IEEE 802.3 and is Class 1 laser eye safe.
- Optical Extinction Ratio is defined as the ratio of the average optical power of the transmitter in the high ("1") state to the low ("0") state. The transmitter is driven with a Gigabit Ethernet 1250 MBd 8b/10b encoded serial data pattern. Optical Extinction Ratio is expressed in decibels (dB) by the relationship $10\log(P_{high\ avg}/P_{low\ avg})$.
- Optical Rise and Fall Times are 20-80% value. Laser transmitter pulse characteristics are typically specified by an eye diagram - see Figure 6. The characteristics include rise time, fall time, pulse overshoot, pulse undershoot and ringing, all of which are controlled to prevent excessive degradation of receiver sensitivity. These parameters are specified by the referenced Gigabit Ethernet eye diagram using the required filter. The output optical waveform complies with the requirements of the eye mask described in IEEE 802.3 section 38.6.10 and Figure 38-2.
- CPR is measured in accordance with EIA/TIA-526-14A as referenced in IEEE 802.3 section 38.6.10.
- Measured at TP2. TP refers to the compliance point specified by IEEE 802.3, section 38.2.1.
- Tested with a 100 mV_{p-p} sinusoidal signal in the frequency range from 10 Hz to 2 MHz on the V_{CC} supply with the recommended power supply filter (with C8) in place. Typically, a change in sensitivity of less than 1 dB is experienced.

Table 8 - Receiver Optical CharacteristicsHFBR-5911LZ ($T_C = 0^\circ\text{C}$ to $+70^\circ\text{C}$, $V_{CC} = 3.14\text{ V}$ to 3.47 V)HFBR-5911ALZ ($T_C = -10^\circ\text{C}$ to $+85^\circ\text{C}$, $V_{CC} = 3.14\text{ V}$ to 3.47 V)

Parameter	Symbol	Minimum	Typical	Maximum	Units	Reference
Input Optical Power	P_{IN}	-17		0	dBm avg.	17
Stressed Receiver Sensitivity 62.5 μm 50 μm				-12.5-13.5	dBm avg.	18
Contributed Total Jitter	TJ			2660.332	psUI	
Receive Electrical 3dB Upper Cutoff Frequency				1500	MHz	19
Operating Center Wavelength	λ_C	770	850	860	nm	
Return Loss	RL	12			dB	20
Signal Detect Assert Power Level	P_A			-17	dBm avg.	21
Signal Detect Deassert Power Level	P_D	-30			dBm avg.	21
Signal Detect Hysteresis	$P_A - P_D$	1.5			dB	21

Table 9 - Transceiver Timing CharacteristicsHFBR-5911LZ ($T_C = 0^\circ\text{C}$ to $+70^\circ\text{C}$, $V_{CC} = 3.14\text{ V}$ to 3.47 V)HFBR-5911ALZ ($T_C = -10^\circ\text{C}$ to $+85^\circ\text{C}$, $V_{CC} = 3.14\text{ V}$ to 3.47 V)

Parameter	Symbol	Minimum	Typical	Maximum	Units	Reference
Tx Disable Assert Time	t_{off}			100	μs	22
Tx Disable Deassert Time	t_{on}			1.0	ms	23
Time to initialize	t_{init}			300	ms	24
Tx Disable Pulse Width to Reset	t_{reset}	10			μs	25
Interval between Transmit Disable Assertions		10			ms	
Signal Detect Assert Time	SD_on			100	μs	26
Signal Detect Deassert Time	SD_off			350	μs	27

Table 10 - PCB Assembly Process Compatibility

Parameter	Symbol	Minimum	Typical	Maximum	Units	Reference
Hand Lead Soldering Temperature/Time	T_{SOLD}/t_{SOLD}			+260/10	$^\circ\text{C} / \text{sec}$	
Wave Soldering and Aqueous Wash	T_{SOLD}/t_{SOLD}			+260/10	$^\circ\text{C} / \text{sec}$	
Aqueous Wash Pressure				110	psi	

Notes:

17. Receiver sensitivity is measured using a worst case extinction ratio penalty while sampling at the center of the eye.
18. Stressed receiver sensitivity is measured using the conformance test signal defined by IEEE 802.3, section 38.6.11. The conformance test signal is conditioned by applying deterministic jitter and intersymbol interference.
19. The Receive Electrical 3 dB Upper Cutoff Frequency of the receiver is measured using the technique outlined in IEEE 802.3, section 38.6.11.
20. Return Loss is defined as the minimum attenuation (dB) of received optical power for energy reflected back into the optical fiber.
21. With valid 8b/10b encoded data.
22. Time from rising edge of Tx_Disable to when modulated optical output falls below 10% of nominal.
23. Time from falling edge of Tx_Disable to when the modulated optical output rises above 90% of nominal.
24. Time from power on or falling edge of Tx_Disable to when the modulated optical output rises above 90% of nominal.
25. Time Tx_Disable must be held high to disable transmitter. Measured from leading edge of Tx_Disable to when the modulated optical output falls below 10% of nominal.
26. Time from SD deassert to SD assert.
27. Time from non-SD assert to SD deassert.

Table 11- Regulatory Compliance

Feature	Test Method	Criteria
Electrostatic Discharge (ESD) to the Electrical Pins	MIL-STD-883C Method 3015.4	Class 1 compliance. Withstands >1500 V.
Electrostatic Discharge (ESD) to the Duplex LC Receptacle	Variation of IEC 61000-4-2	Typically withstands at least 25 kV without damage when the duplex LC connector receptacle is contacted by a Human Body Model probe. Fulfills Live Traffic ESD testing up to 8 kV with less than 1 errored second.
Electromagnetic Interference (EMI)	FCC Class BCENELEC EN55022 Class B (CISPR 22A) Class 1	Margins are dependent on customer board and Chassis design.
Immunity	Variation of IEC 6100-4-3	Typically shows no measurable effect from a 10 mV/m field swept from 80 to 1000 MHz applied to the transceiver without a chassis enclosure.
Eye Safety	US FDA CDRH AEL Class 1EN (IEC) 60825-1, 2, EN60950 Class 1	CDRH certification # 9720151-24TUV file # E9971083.14UL file # E173874
Component Recognition	Underwriter's Laboratories and Canadian Standards Association Joint Component Recognition for Information Technology Equipment Including Electrical Business Equipment	UL file # E173874
RoHS Compliance		Less than 1000 ppm of cadmium, lead, mercury, hexavalent chromium, polybrominated biphenyls, and polybrominated biphenyl ethers.

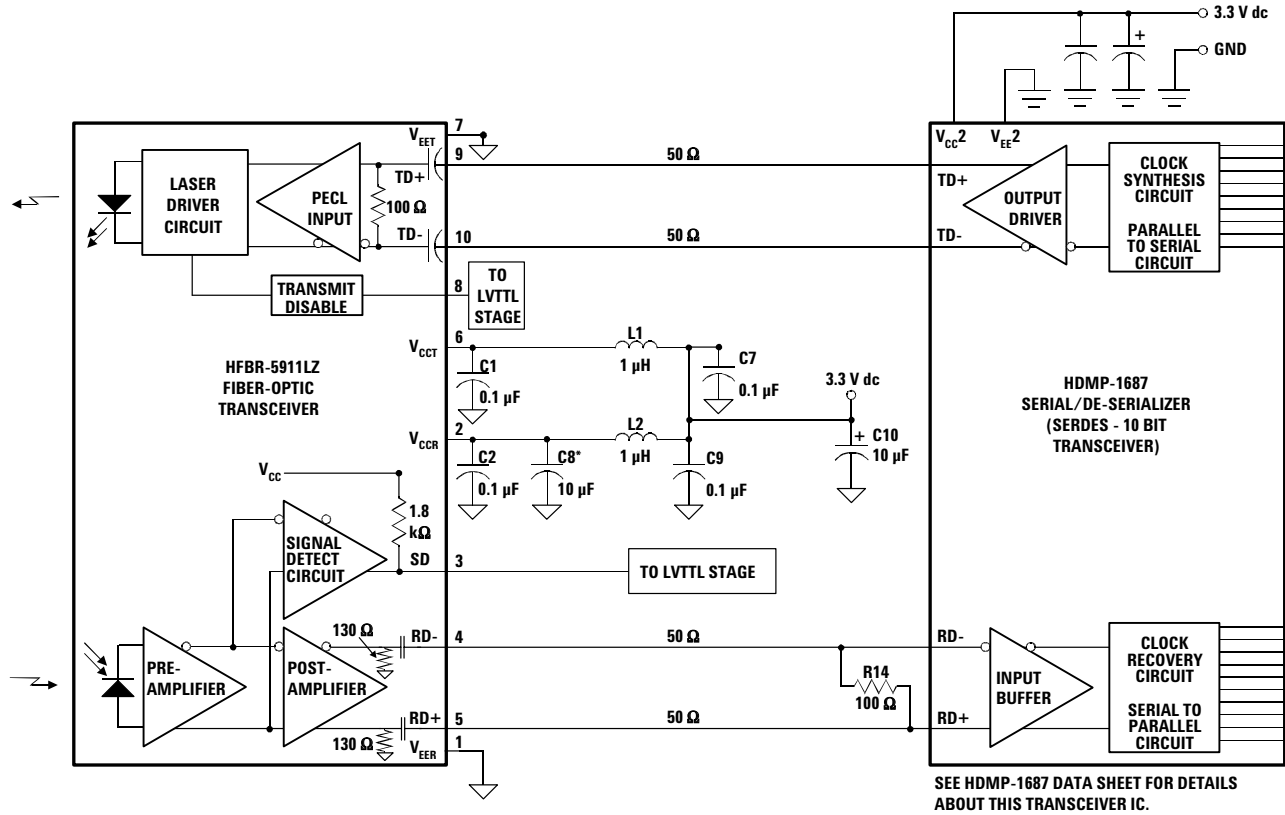

NOTES:

- USE SURFACE-MOUNT COMPONENTS FOR OPTIMUM HIGH-FREQUENCY PERFORMANCE.
- USE 50 Ω MICROSTRIP OR STRIPLINE FOR SIGNAL PATHS.
- LOCATE 50 Ω TERMINATIONS AT THE INPUTS OF RECEIVING UNITS.
- *C8 IS A RECOMMENDED BYPASS CAPACITOR FOR ADDITIONAL LOW FREQUENCY NOISE FILTERING.
- THE SIGNAL DETECT OUTPUT ON THE HFBR-5911LZ CONTAINS AN INTERNAL 1.8 kΩ PULL UP RESISTOR. THE OUTPUT STAGE ON THE HFBR5911L IS A PUSH PULL CONFIGURATION AND THEREFORE DOES NOT REQUIRE AN EXTERNAL PULL UP RESISTOR.

Figure 2 - Recommended Gigabit/sec Ethernet HFBR-5911LZ/ALZ Fiber-Optic Transceiver and HDMP-1687 SERDES Integrated Circuit Transceiver Interface and Power Supply Filter Circuits.

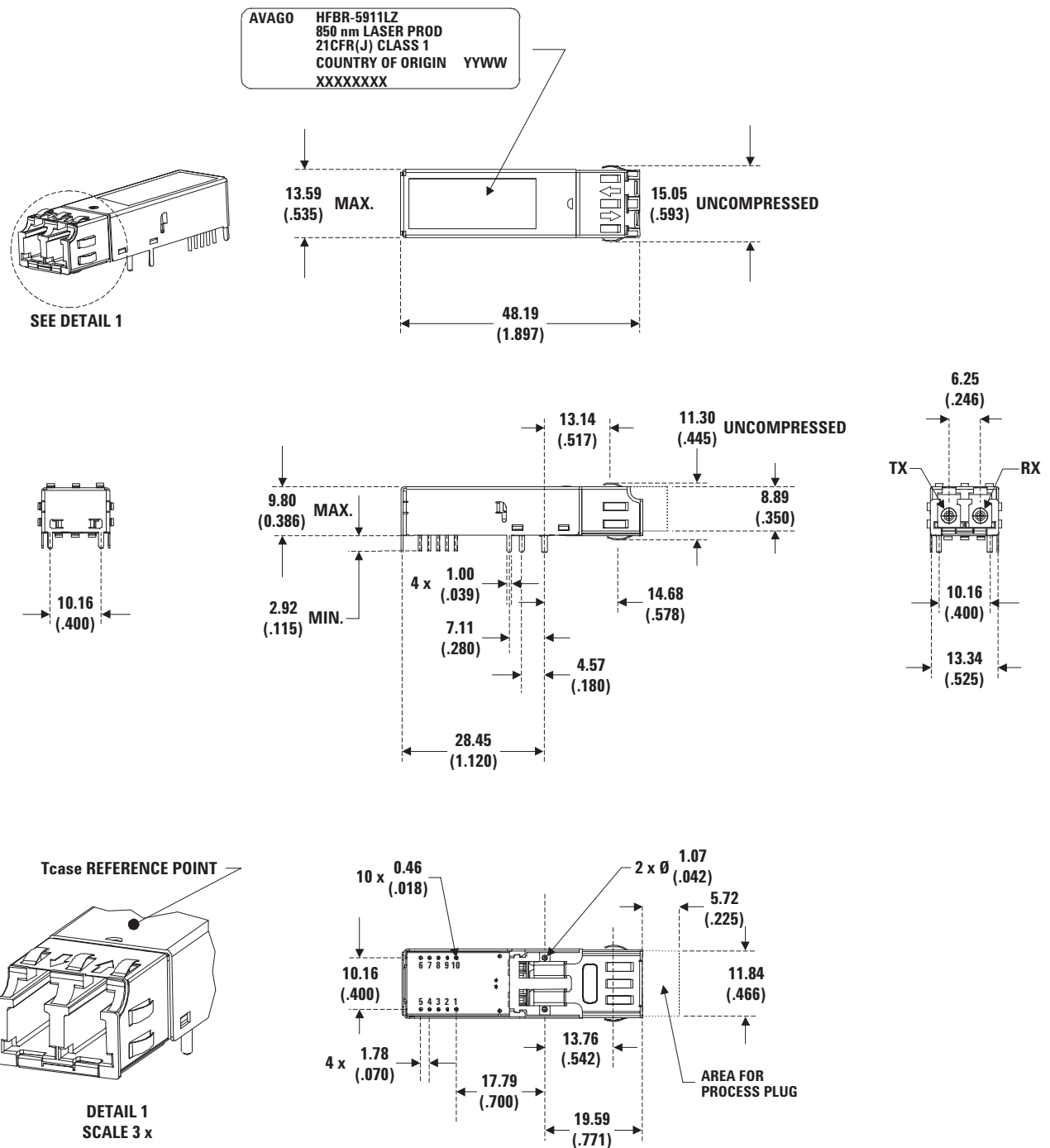

ALL DIMENSIONS IN MILLIMETERS (INCHES)

Figure 3 - External Configuration

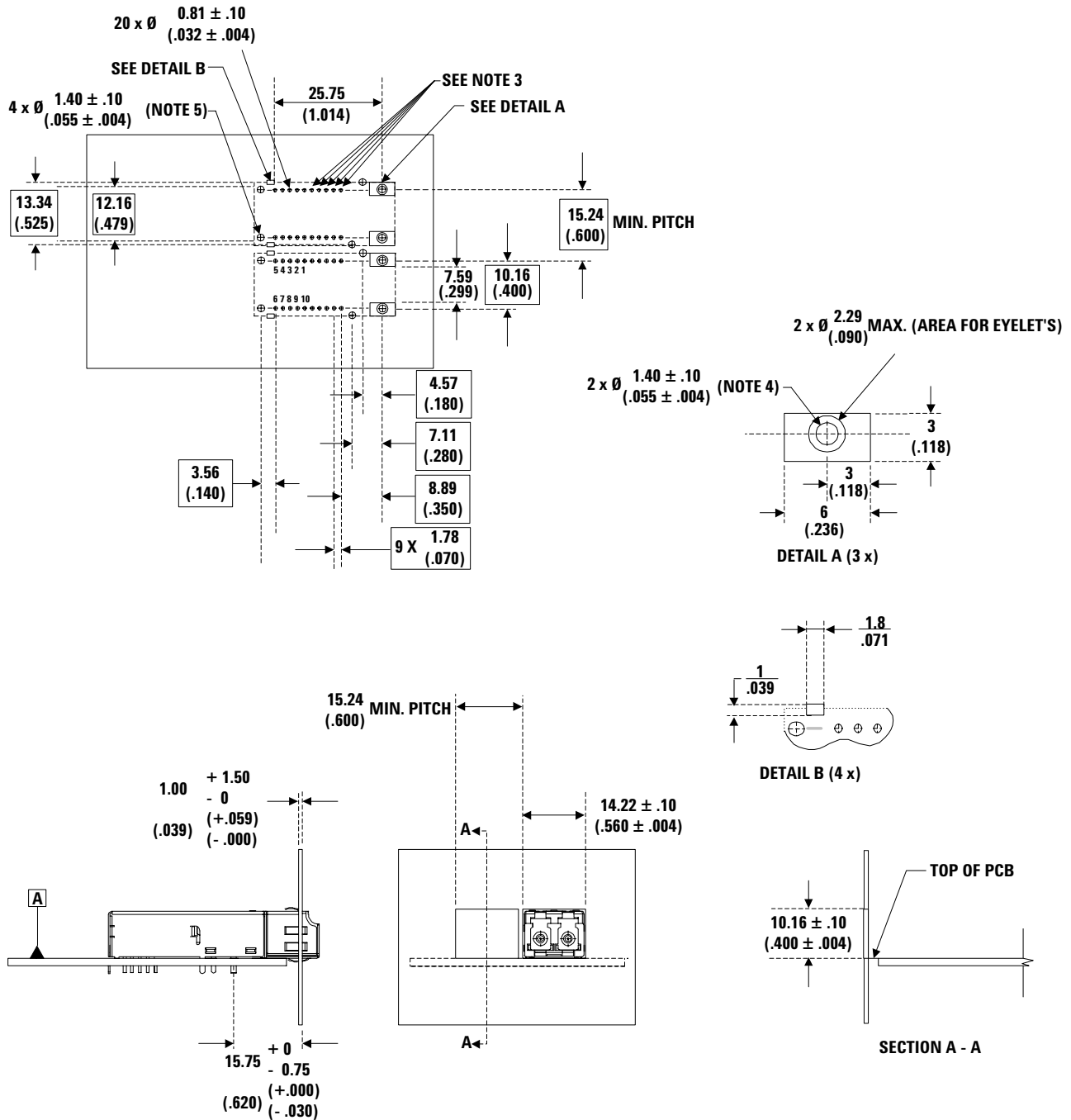

NOTES:

1. THIS PAGE DESCRIBES THE RECOMMENDED CIRCUIT BOARD LAYOUT AND FRONT PANEL OPENINGS FOR SFF TRANSCEIVERS.
2. THE HATCHED AREAS ARE KEEP-OUT AREAS RESERVED FOR HOUSING STANDOFFS. NO METAL TRACES ALLOWED IN KEEP-OUT AREAS.
3. THIS DRAWING SHOWS EXTRA PIN HOLES FOR 2 x 6 PIN AND 2 x 10 PIN TRANSCEIVERS. THESE EXTRA HOLES ARE NOT REQUIRED FOR HFBR-5911LZ AND OTHER 2 x 5 PIN SFF MODULES.
4. HOLES FOR MOUNTING STUDS MUST NOT BE TIED TO SIGNAL GROUND BUT MAY BE TIED TO CHASSIS GROUND.
5. HOLES FOR HOUSING LEADS MUST BE TIED TO SIGNAL GROUND.
6. ALL DIMENSIONS ARE IN MILLIMETERS (INCHES).

Figure 4 - Recommended host board layout (from SFF MSA)

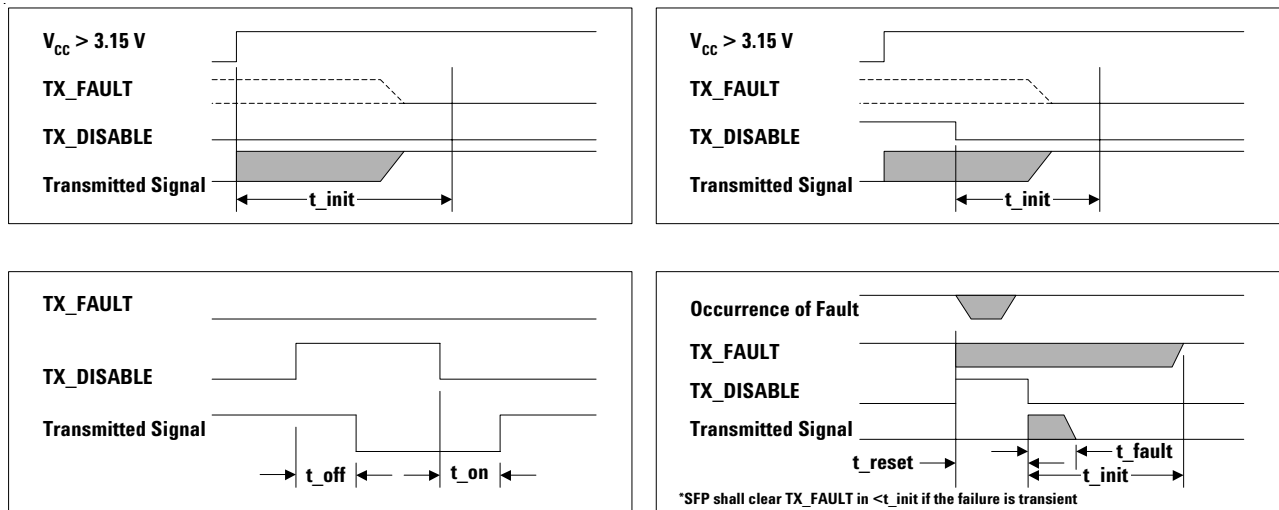

Figure 5 - Transceiver timing diagrams

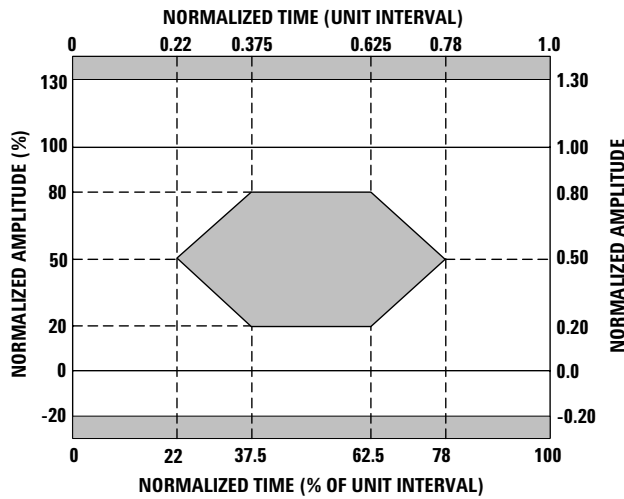

Figure 6 - Gigabit Ethernet Transmitter eye mask diagram

Ordering Information

The HFBR-5911LZ/ALZ is available for production orders through the Avago Technologies Component Field Sales Offices and Authorized Distributors world wide.

Temperature ranges

0 °C to +70 °C - HFBR-5911LZ
 -10 °C to +85 °C - HFBR-5911ALZ

For product information and a complete list of distributors, please go to our web site: www.avagotech.com

Avago, Avago Technologies, and the A logo are trademarks of Avago Technologies in the United States and other countries. Data subject to change. Copyright © 2005-2013 Avago Technologies. All rights reserved. AV01-0048EN - July 11, 2013

Avago
TECHNOLOGIES

X-ON Electronics

Largest Supplier of Electrical and Electronic Components

Click to view similar products for [foxconn](#) manufacturer:

Other Similar products are found below :

[AFBR-709DMZ](#) [JPD1030-N521-4F](#) [2EGL4997-B2DM-4F](#) [AFCT-57F3ATMZ](#) [AFBR-57R6AEZ](#) [3H993921-4M41-02H](#) [DZ11A51-H8R1-4F](#)
[AFCT-739ASMZ](#) [3H993321-4M41-01H](#) [DT00151-H1A2-4F](#) [AFBR-89CEDZ](#) [UH51543-BW11-7F](#) [2EG14917-D2D8-4F](#) [JFM38U11-B313-4F](#)
[LU25683-A001-9H](#) [UEA11121-8FS6-4F](#) [LD1807F-S54TD](#) [UB11123-8Z4-7F](#) [AS0B226-S99Q-7H](#) [2EG08217-D2D-DF](#) [WNMEL00-84N00-EH](#)
[AFBR-5715APZ](#) [HM3512E-P2](#) [DT10121-H4W2-4F](#) [ABCU-5740ARZ](#) [AS0A621-HARN-7H](#) [AS0A621-HASN-7H](#) [AFBR-79EIPZ-F5](#)
[AFCT-5961ATLZ](#) [AS0A621-H2S6-7H](#) [ASAA821-EARB0-7H](#) [WQ21823-DES1-7F](#) [AS0BC21-S40BE-7H](#) [AFBR-5715PZ](#)
[AFBR-59R5LZ](#) [AFBR-57R5APZ](#) [AFBR-57R6APZ](#) [UEA1112C-4HK1-4H](#) [AS0B326-S78N-7F](#)