

TRIO mXTEND™ (FR01-S4-210) – A standard antenna solution for mobile frequency bands

Fractus Antennas specializes in enabling effective mobile communications. Using Fractus Antennas technology, we design and manufacture optimized antennas to make your wireless devices more competitive. Our mission is to help our clients develop innovative products and accelerate their time to market through our expertise in antenna design, testing and manufacturing.



TRIO mXTEND™ chip antenna component

FR01-S4-210

Fractus Antennas products are protected by [Fractus Antennas patents](#).

All information contained within this document is property of Fractus Antennas and is subject to change without prior notice. Information is provided “as is” and without warranties. It is prohibited to copy or reproduce this information without prior approval.

Fractus Antennas is an ISO 9001:2015 certified company. All our antennas are lead-free and RoHS compliant.

ISO 9001: 2015 Certified



INDEX OF CHAPTERS

1. PRODUCT DESCRIPTION FR01-S4-210	4
2. EVALUATION BOARD (698-960MHz and 1710-2690MHz)	5
3. CAPABILITIES AND MEASUREMENT SYSTEMS	10
4. MECHANICAL CHARACTERISTICS FR01-S4-210	11
5. ASSEMBLY PROCESS	13
6. PACKAGING	15

TABLE OF CONTENTS

1. PRODUCT DESCRIPTION FR01-S4-210	4
2. EVALUATION BOARD (698-960MHz and 1710-2690MHz)	5
2.1. QUICK REFERENCE GUIDE	5
2.2. EVALUATION BOARD (698-960 MHz and 1710-2690 MHz)	5
3. CAPABILITIES AND MEASUREMENT SYSTEMS	10
4. MECHANICAL CHARACTERISTICS FR01-S4-210.....	11
4.1. DIMENSIONS, TOLERANCES, AND RoHS	11
4.2. COLOR RANGE FOR THE INK.....	11
4.3. RECOMMENDED FOOTPRINT FOR THE FR01-S4-210	12
5. ASSEMBLY PROCESS	13
6. PACKAGING	15

1. PRODUCT DESCRIPTION FR01-S4-210

The TRIO mXTEND™ chip antenna component has been specifically designed for providing the major level of flexibility to operate any required frequency band inside any wireless device. TRIO mXTEND™ chip antenna component is capable of operating the main mobile communication standards, enabling worldwide coverage, such as GSM850, GSM900, GSM1800/DCS, GSM1900/PCS, UMTS, LTE700, LTE800, LTE850, LTE900, LTE1700, LTE1800, LTE1900, LTE2000, LTE2100, LTE2300, LTE2500, and LTE2600, (698-960MHz and 1710-2690MHz), the main short range wireless bands such as Bluetooth and Wi-Fi (2400-2500MHz and 4900-5875MHz), as well as the Global Navigation Systems such as GPS, Glonass, and Beidou (1561 MHz, 1575 MHz and 1598-1606 MHz) through the same antenna component. The TRIO mXTEND™ chip antenna component offers the flexibility to be tuned at the frequency regions of interest through the proper adjustment of the matching network. This characteristic provides an important benefit since removes the need of including different antenna parts inside the same wireless device for operating different communication standards, thus reducing considerably the integration complexity while saving costs. The results gathered herein presents how the matching network should be configured for operating the main mobile communication standards.

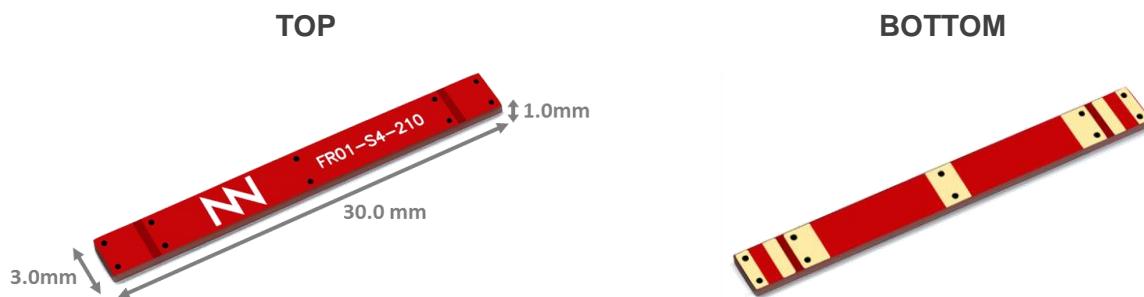

Material: The TRIO mXTEND™ chip antenna component is built on glass epoxy substrate.

APPLICATIONS

- Handsets
- Smartphones
- Tablets
- Laptop PCs
- Smart Meters
- IoT Devices
- Modules
- Routers

BENEFITS

- High efficiency
- Small size
- Cost-effective
- Easy-to-use (pick and place)
- Multiband behaviour (worldwide standards)
- Off-the-Shelf Standard Product (no customization is required)

The TRIO mXTEND™ chip antenna component belongs to a new generation of antenna solutions based on the Virtual Antenna™ technology owned by Fractus Antennas. The technology is mainly focused on replacing conventional antenna solutions by miniature and standard components.

2. EVALUATION BOARD (698-960MHz and 1710-2690MHz)

2.1. QUICK REFERENCE GUIDE

Technical features	698 – 960 MHz	1710 – 2690 MHz
Average Efficiency	> 55 %	> 65 %
Peak Gain	1.1 dBi	2.4 dBi
VSWR	< 3:1	
Radiation Pattern	Omnidirectional	
Polarization	Linear	
Weight (approx.)	0.25 g.	
Temperature	-40 to + 85 °C	
Impedance	50 Ω	
Dimensions (L x W x H)	30.0 mm x 3.0 mm x 1.0 mm	

Table 1 – Technical features. Measures from the Evaluation Board. See Figure 1. Note that for obtaining comparable results, a ground plane length larger than 100 mm is recommended.

2.2. EVALUATION BOARD (698-960 MHz and 1710-2690 MHz)

This Evaluation Board (part number: EB_FR01-S4-210-M) integrates one TRIO mXTEND™ chip antenna component to provide operation in two frequency regions, from 698 MHz to 960 MHz and from 1710 MHz to 2690 MHz. A UFL cable connects this single input/output port to the SMA connector.

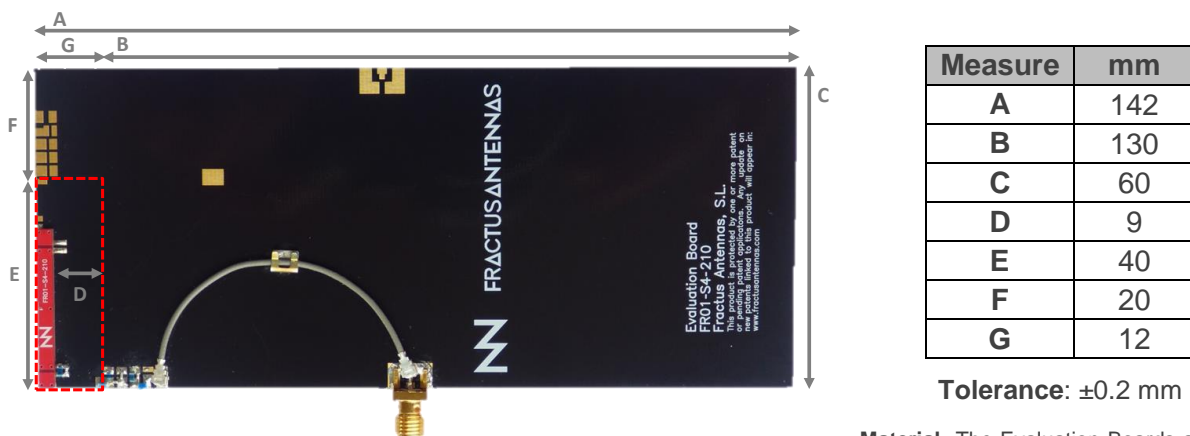

Figure 1 – EB_FR01-S4-210-M. Evaluation Board for providing operation in 2 frequency ranges, 698 – 960MHz and 1710 – 2690MHz.

Material: The Evaluation Boards are built on FR4 substrate. Thickness is 1 mm.

Clearance Area: 40 mm x 12 mm (ExG)

This product and its use are protected by at least one or more of the following [patents and patent applications](#) PAT. US 62/529032; and other domestic and international patents pending. Additional information about patents related to this product is available at www.fractusantennas.com/virtual-antenna/.

2.2.1. MATCHING NETWORK

The specs of a Fractus Antennas standard product are measured in their Evaluation Board, which is an ideal case. In a real design, components nearby the antenna, LCD's, batteries, covers, connectors, etc. affect the antenna performance. This is the reason why it is highly recommended placing pads compatible with 0402 and 0603 SMD components for a matching network as close as possible to the feeding point. Do it in the ground plane area, not in the clearance area. This provides a degree of freedom to tune the TRIO mXTEND™ chip antenna component once the design is finished and taking into account all elements of the system (batteries, displays, covers, etc.).

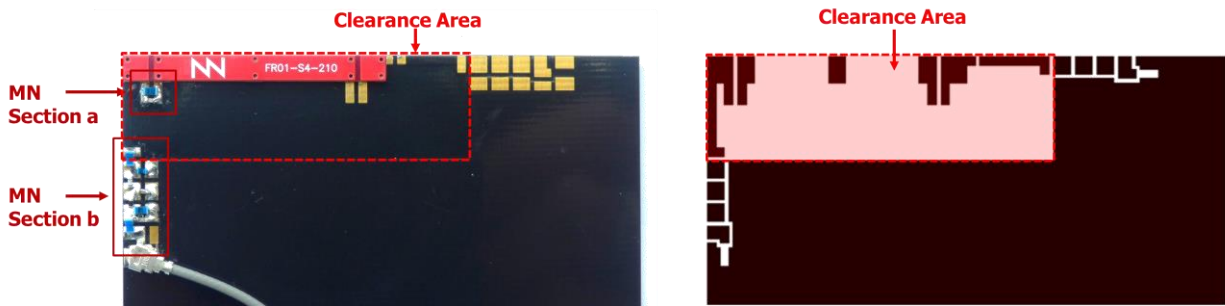

Figure 2 – Matching network distribution

Please notice that different devices with different ground planes and different components nearby the TRIO mXTEND™ chip antenna component may need a different matching network. To ensure optimal results, the use of high Q and tight tolerance components is highly recommended (Murata components).

698 MHz – 960 MHz and 1710 MHz – 2690 MHz																	
MN Section a	<div style="display: flex; align-items: center; justify-content: center;">  <table border="1" style="margin-left: 20px;"> <thead> <tr> <th>Value</th> <th>Part Number</th> </tr> </thead> <tbody> <tr> <td>15 nH</td> <td>LQW18AN15NG80</td> </tr> <tr> <td>0.3 pF</td> <td>GJM1555C1HR30WB01</td> </tr> </tbody> </table> </div>	Value	Part Number	15 nH	LQW18AN15NG80	0.3 pF	GJM1555C1HR30WB01										
Value	Part Number																
15 nH	LQW18AN15NG80																
0.3 pF	GJM1555C1HR30WB01																
MN Section b	<div style="display: flex; align-items: center; justify-content: center;">  <table border="1" style="margin-left: 20px;"> <thead> <tr> <th>Value</th> <th>Part Number</th> </tr> </thead> <tbody> <tr> <td>2.2 nH</td> <td>LQW18AN2N2C80</td> </tr> <tr> <td>8.6 nH</td> <td>LQW15AN8N6G80</td> </tr> <tr> <td>2.2 pF</td> <td>GJM1555C1H2R2WB01</td> </tr> <tr> <td>1.0 pF</td> <td>GJM1555C1H1R0WB01</td> </tr> <tr> <td>10 nH</td> <td>LQW18AN10NG80</td> </tr> <tr> <td>0.36 pF</td> <td>GJM1555C1HR36WB01</td> </tr> <tr> <td>3.0 nH</td> <td>LQW18AN3N0C80</td> </tr> </tbody> </table> </div>	Value	Part Number	2.2 nH	LQW18AN2N2C80	8.6 nH	LQW15AN8N6G80	2.2 pF	GJM1555C1H2R2WB01	1.0 pF	GJM1555C1H1R0WB01	10 nH	LQW18AN10NG80	0.36 pF	GJM1555C1HR36WB01	3.0 nH	LQW18AN3N0C80
Value	Part Number																
2.2 nH	LQW18AN2N2C80																
8.6 nH	LQW15AN8N6G80																
2.2 pF	GJM1555C1H2R2WB01																
1.0 pF	GJM1555C1H1R0WB01																
10 nH	LQW18AN10NG80																
0.36 pF	GJM1555C1HR36WB01																
3.0 nH	LQW18AN3N0C80																

Figure 3 – Matching network implemented in the Evaluation Board 1 port (Figure 1).

This matching network applies to this Evaluation Board. Other configurations would require a matching network adjustment. Please contact info@fractusantennas.com for more information related to the matching service for a chip antenna component.

2.2.2. VSWR AND TOTAL EFFICIENCY

VSWR (Voltage Standing Wave Ratio) and Total Efficiency versus Frequency (GHz).

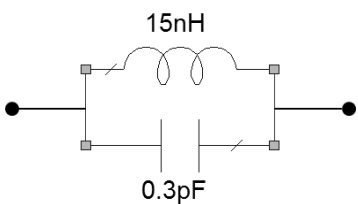
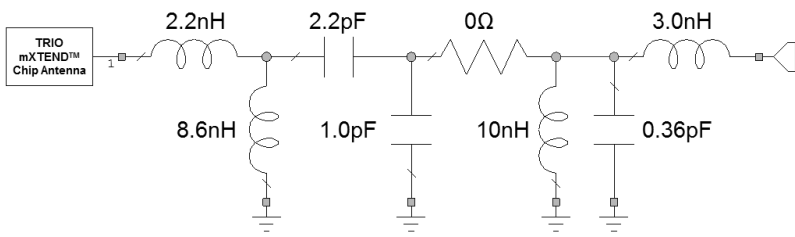
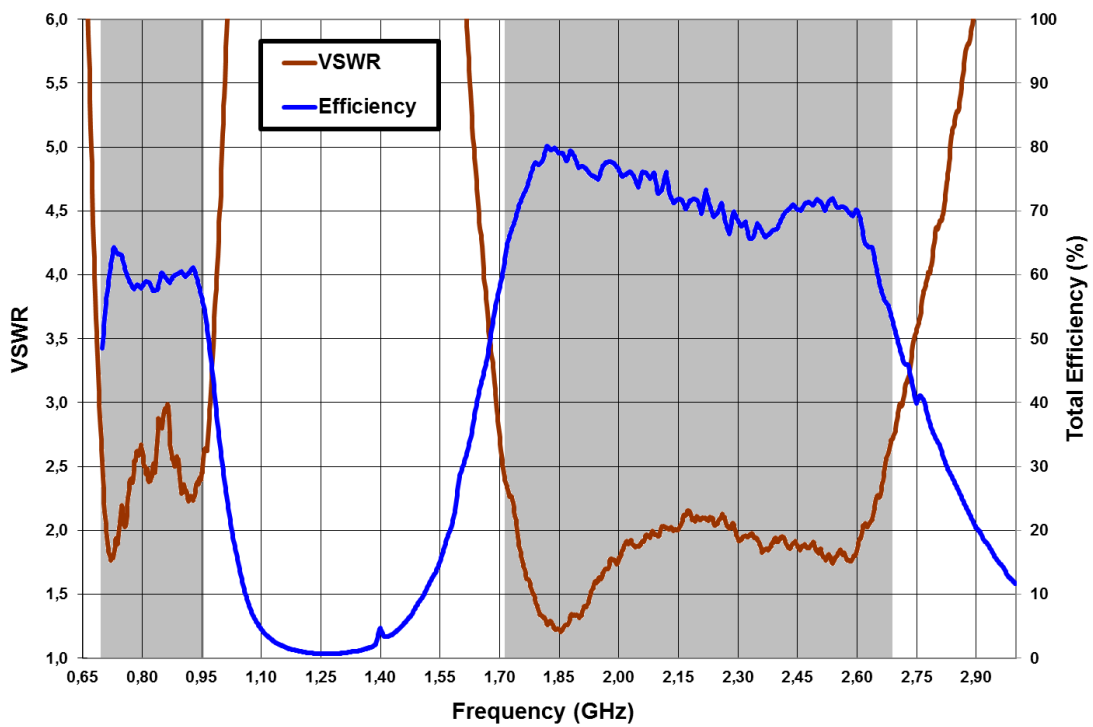
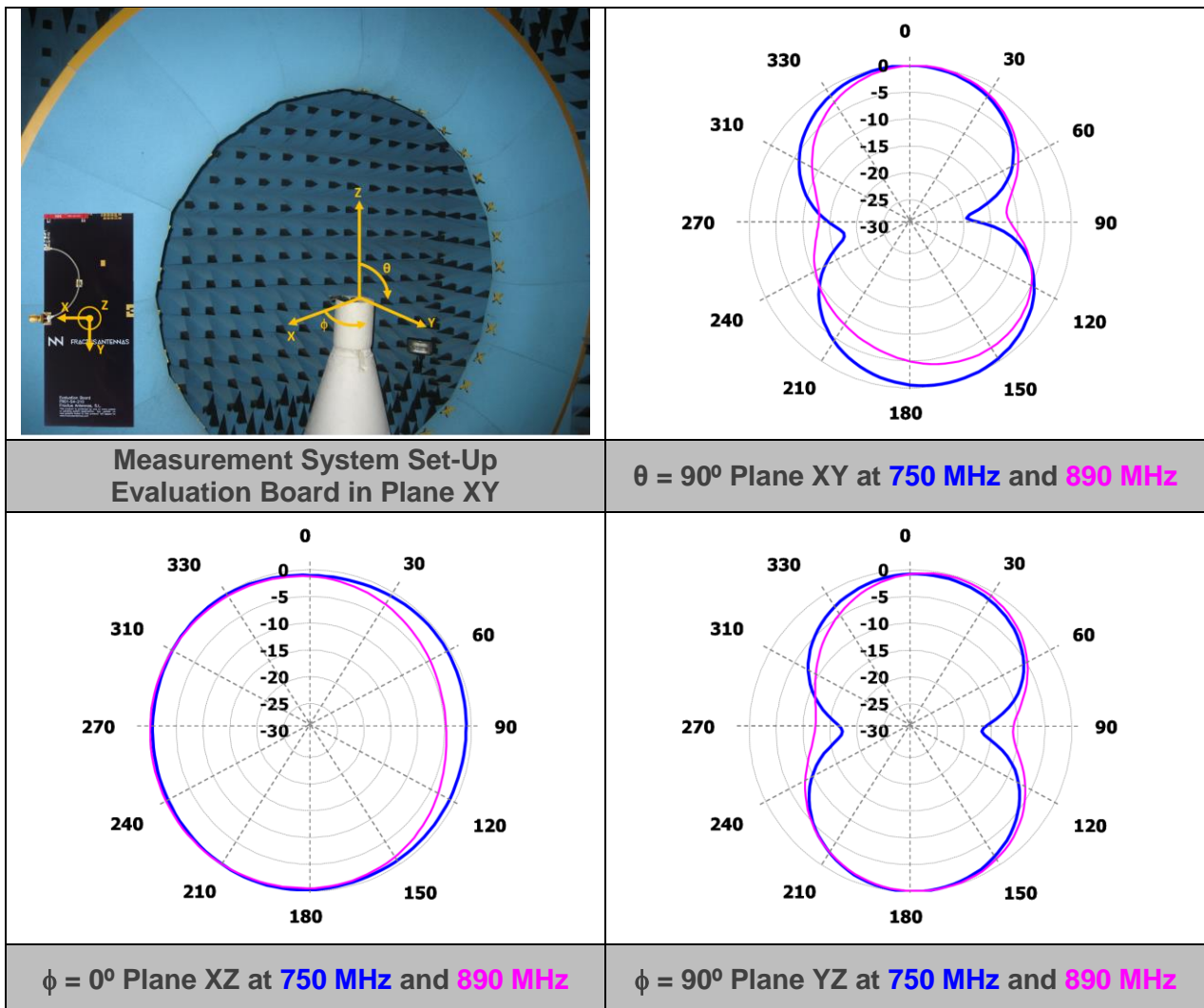

Figure 4 – VSWR and Total Efficiency for the 698 – 960 MHz frequency range and for the 1710 – 2690 MHz frequency range (from the Evaluation Board) (Figure 1).

2.2.3. RADIATION PATTERNS (698-960 MHz), GAIN AND EFFICIENCY



Gain	Peak Gain	1.1 dBi
	Average Gain across the band	0.5 dBi
	Gain Range across the band (min, max)	-0.7 <-> 1.1 dBi
Efficiency	Peak Efficiency	64.3 %
	Average Efficiency across the band	59.3 %
	Efficiency Range across the band (min, max)	48.5 – 64.3 %

Table 2 – Antenna Gain and Total Efficiency from the Evaluation Board (Figure 1) within the 698 – 960 MHz frequency range. Measures made in the Satimo STARGATE 32 anechoic chamber.

2.2.4. RADIATION PATTERNS (1710-2690 MHz) GAIN, AND EFFICIENCY

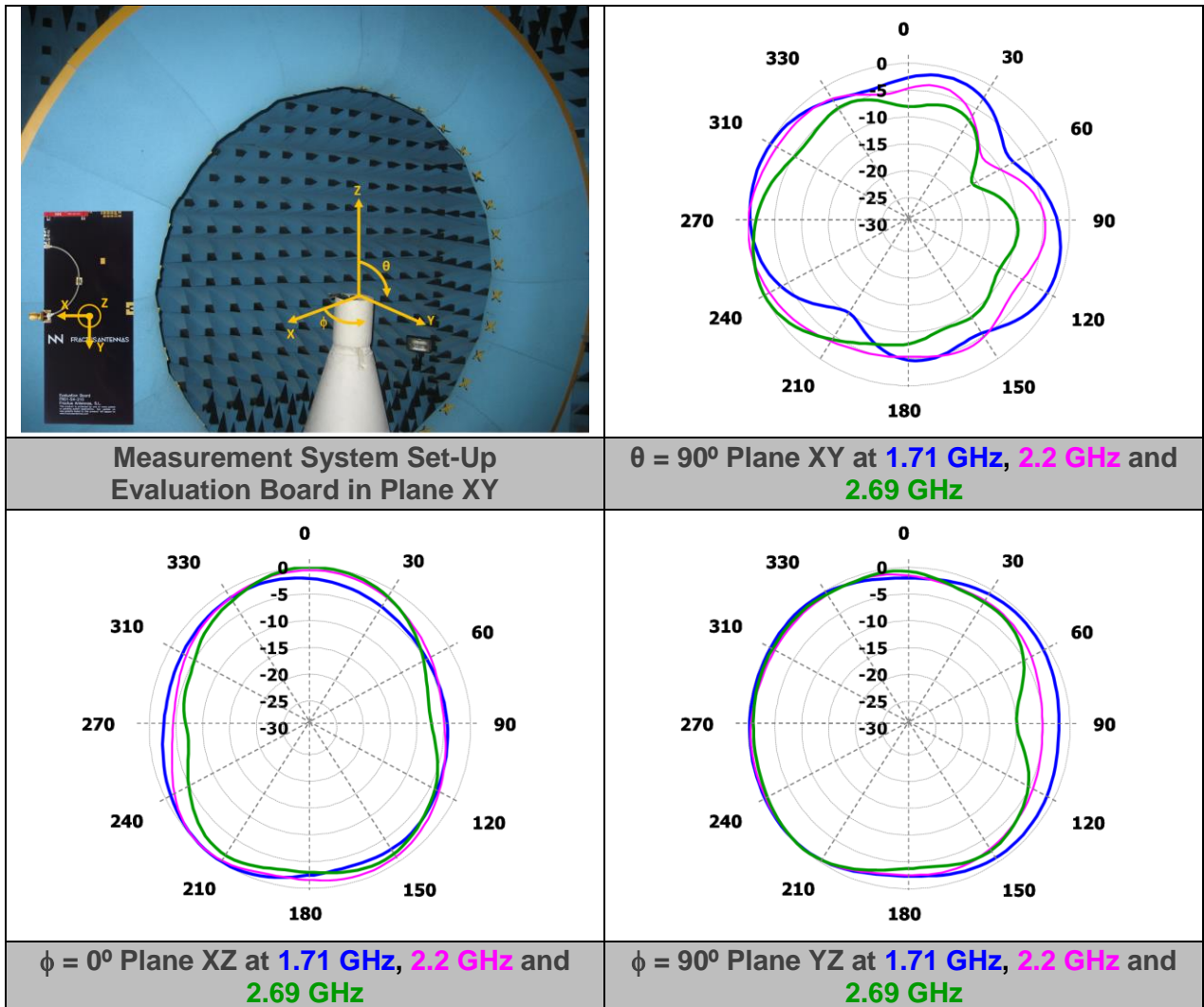

Gain	Peak Gain	2.4 dBi
	Average Gain across the band	1.8 dBi
	Gain Range across the band (min, max)	0.3 <-> 2.4 dBi
Efficiency	Peak Efficiency	80.2 %
	Average Efficiency across the band	71.4 %
	Efficiency Range across the band (min, max)	52.9 – 80.2 %

Table 3 – Antenna Gain and Total Efficiency for the Evaluation Board (Figure 1) within the 1710 – 2690 MHz frequency range. Measures made in the Satimo STARGATE 32 anechoic chamber.

3. CAPABILITIES AND MEASUREMENT SYSTEMS

Fractus Antennas specializes in designing and manufacturing optimized antennas for wireless applications and providing our clients with RF expertise. We offer turn-key antenna products and antenna integration support to minimize your time requirement and maximize your return on investment during your product development efforts. We also provide our clients with the opportunity to leverage our in-house testing and measurement facilities to obtain accurate results quickly and efficiently.

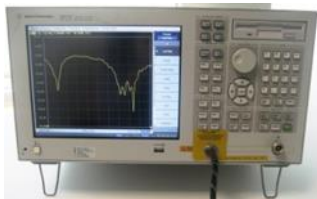

Agilent E5071B

VSWR
&
S Parameters

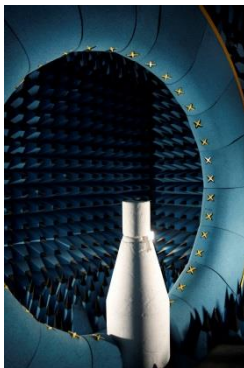
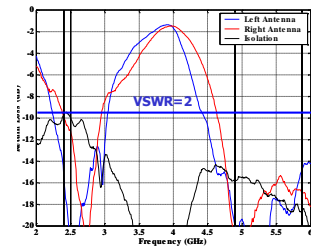

SATIMO STARGATE 32

Radiation
Pattern
&
Efficiency

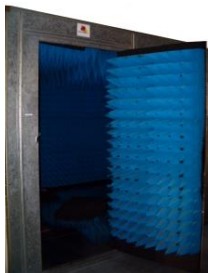
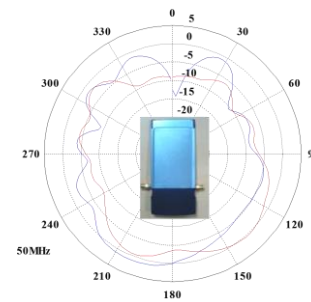

Anechoic chambers and full equipped in-house lab

4. MECHANICAL CHARACTERISTICS FR01-S4-210

4.1. DIMENSIONS, TOLERANCES, AND RoHS

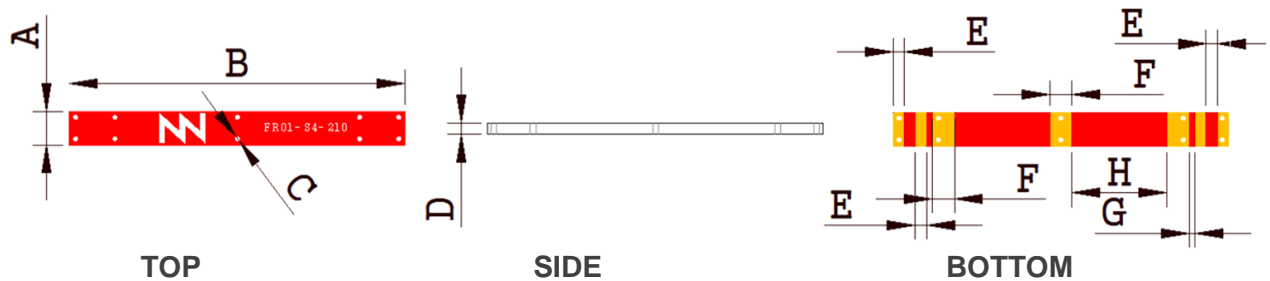

Dimension	mm	Dimension	mm
A	3.0 ± 0.15	B	30.0 ± 0.20
C	0.5 ± 0.10	D (height)	1.0 ± 0.10
E	1.0 ± 0.05	F	2.0 ± 0.05
G	0.5 ± 0.05	H	8.5 ± 0.05

Figure 5 – TRIO mXTEND™ chip antenna component dimensions and tolerances.

The TRIO mXTEND™ chip antenna component FR01-S4-210 is compliant with the restriction of the use of hazardous substances (RoHS). For more information, please contact info@fractusantennas.com.

4.2. COLOR RANGE FOR THE INK

Next figure shows the range of the colors in the TRIO mXTEND™ chip antenna component:

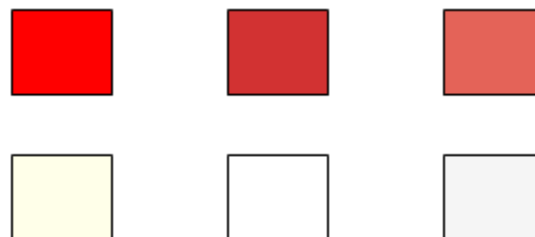

Acceptable color range

4.3. RECOMMENDED FOOTPRINT FOR THE FR01-S4-210

Assuming that the TRIO mXTEND™ chip antenna component FR01-S4-210 is placed in the clearance area of the PCB, see below the recommended footprint dimensions.

Measure	mm
A	12.0
B	23.0
C	3.0
D	0.5
E	1.0
F	8.5
G	2

Tolerance: ±0.05mm

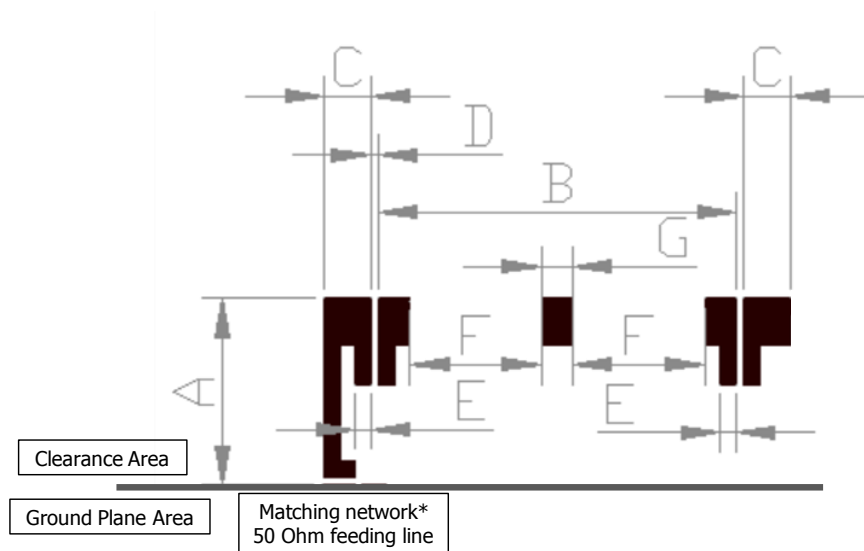

Figure 6 – Footprint dimensions for the single chip antenna component.

For additional support in the integration process, please contact info@fractusantennas.com.

5. ASSEMBLY PROCESS

Figure 7 shows the back and front views of the TRIO mXTEND™ chip antenna component FR01-S4-210. Due to the product configuration, the feeding pad can only be the pad 1.

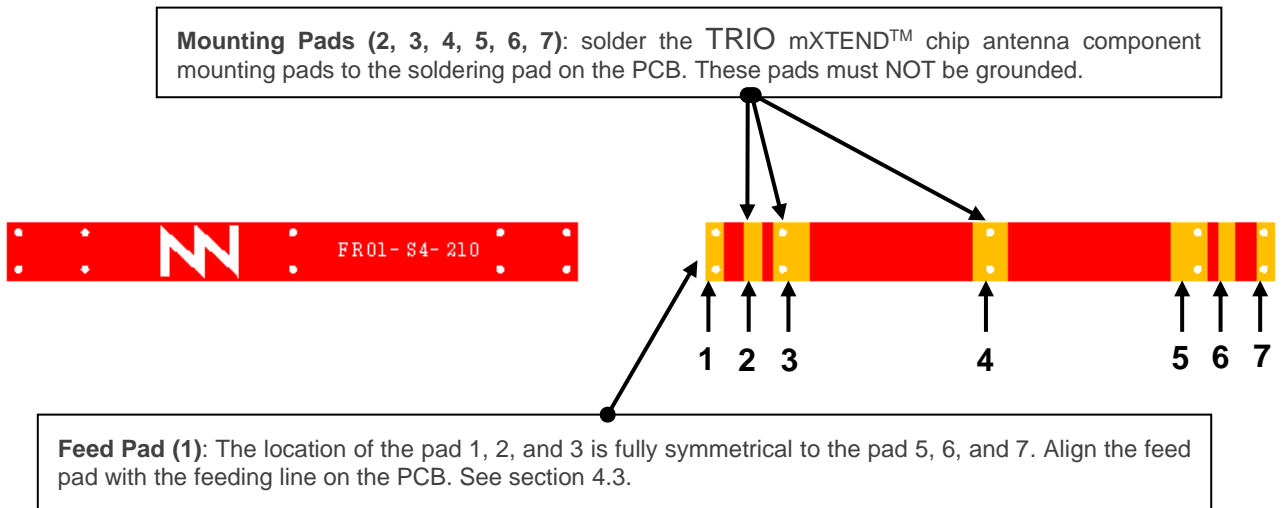

Figure 7 – Pads of the TRIO mXTEND™ chip antenna component FR01-S4-210.

As a surface mount device (SMD), the TRIO mXTEND™ chip antenna component is compatible with industry standard soldering processes. The basic assembly procedure for the TRIO mXTEND™ chip antenna component is as follows:

1. Apply a solder paste on the pads of the PCB. Place the TRIO mXTEND™ chip antenna component on the board.
2. Perform a reflow process according to the temperature profile detailed in Table 4, Figure 9.
3. After soldering the TRIO mXTEND™ chip antenna component to the circuit board, perform a cleaning process to remove any residual flux. Fractus Antennas recommends conducting a visual inspection after the cleaning process to verify that all reflux has been removed.

The drawing below shows the soldering details obtained after a correct assembly process:

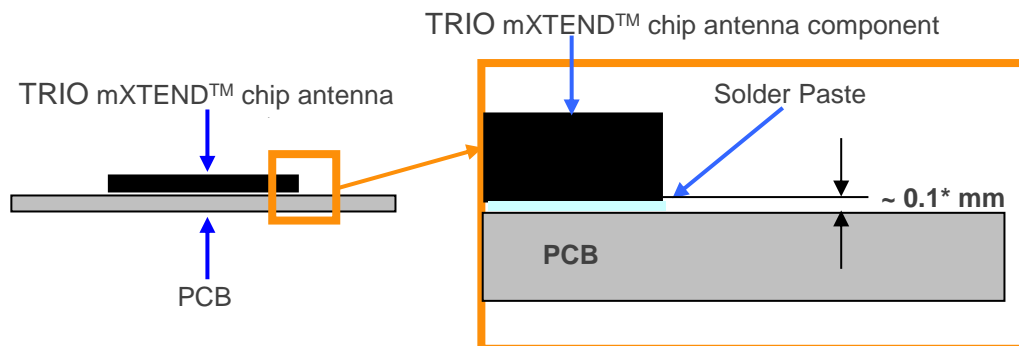

Figure 8 – Soldering Details.

NOTE(*): Solder paste thickness after the assembly process will depend on the thickness of the soldering stencil mask. A stencil thickness equal or larger than **127 microns (5 mils)** is required.

The TRIO mXTEND™ chip antenna component FR01-S4-210 can be assembled following the Pb-free assembly process. According to the Standard **IPC/JEDEC J-STD-020C**, the temperature profile suggested is as follows:

Phase	Profile features	Pb-Free Assembly (SnAgCu)
RAMP-UP	Avg. Ramp-up Rate (T _{smax} to T _p)	3 °C / second (max.)
PREHEAT	- Temperature Min (T _{smin}) - Temperature Max (T _{smax}) - Time (t _{smin} to t _{smax})	150 °C 200 °C 60-180 seconds
REFLOW	- Temperature (T _L) - Total Time above T _L (t _L)	217 °C 60-150 seconds
PEAK	- Temperature (T _p) - Time (t _p)	260 °C 20-40 seconds
RAMP-DOWN	Rate	6 °C/second max
Time from 25 °C to Peak Temperature		8 minutes max

Table 4 – Recommended soldering temperatures.

Next graphic shows temperature profile (grey zone) for the TRIO mXTEND™ chip antenna component assembly process reflow ovens.

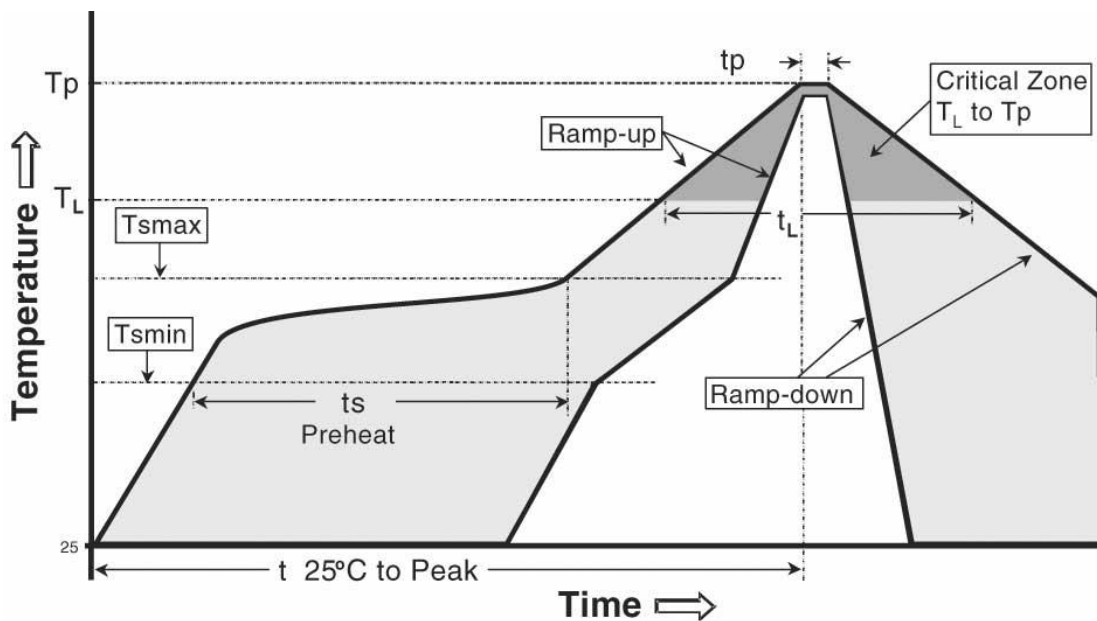
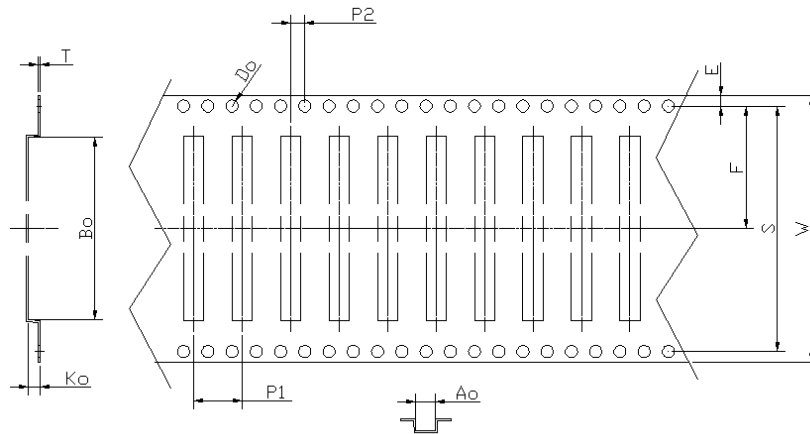

Figure 9 – Temperature profile.

6. PACKAGING

The TRIO mXTEND™ chip antenna component FR01-S4-210 is delivered in tape and reel packaging.



Measure	mm
Ao	3.3 ± 0.1
Bo	30.3 ± 0.1
Ko	2 ± 0.1
W	44 ± 0.3
D0	1.5 ± 0.05
P1	8 ± 0.1
P0	4 ± 0.1
P2	2 ± 0.1
E	1.75 ± 0.1
F	20.2 ± 0.1
S	40.4 ± 0.3
T	0.3 ± 0.05

Figure 10 – Tape dimensions and Tolerances.

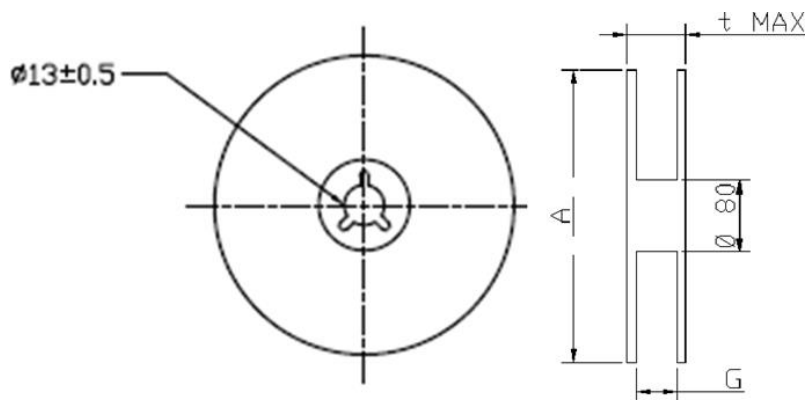

Measure	mm		
A	330	±	2.0
G	44.4	±	0.13
t MAX	48.4	±	0.13

Reel Capacity: 2500 pcs

Figure 11 – Reel Dimensions and Capacity.



Figure 12 – Image of the tape

X-ON Electronics

Largest Supplier of Electrical and Electronic Components

Click to view similar products for [Other Tools](#) category:

Click to view products by [Fractus](#) manufacturer:

Other Similar products are found below :

[CR-05FL7--150R](#) [CR-05FL7--698K](#) [899-2-KT46](#) [899-5-KT46](#) [CR-0AFL4--332K](#) [CR-12FP4--260R](#) [CRCW04021100FRT7](#)
[CRCW04021961FRT7](#) [5800-0090](#) [CRCW04024021FRT7](#) [CRCW040254R9FRT7](#) [CRCW0603102JRT5](#) [59065-5](#) [00-8273-RDPP](#) [00-8729-](#)
[WHPP](#) [593033](#) [593058](#) [593072](#) [593564100](#) [593575](#) [593591](#) [593593](#) [011349-000](#) [CRCW08052740FRT1](#) [LUC-012S070DSM](#) [LUC-](#)
[018S070DSP](#) [599-2021-3-NME](#) [599-JJ-2021-03](#) [00-5080-YWPP](#) [5E4750/01-20R0-T/R](#) [LW1A-L1-GL](#) [LW1A-P1-GD](#) [LW1L-A1C10V-GL](#)
[LW1L-M1C70-A](#) [0202-0173](#) [00-9089-RDPP](#) [00-9300-RDPP](#) [CRCW2010331JR02](#) [01-1003W-8/32-10](#) [601-GP-08-KT39](#) [601-JJ-06](#) [601-SPB](#)
[601YSY](#) [602-JJ-03](#) [602SPB](#) [602Z](#) [603-JJ-07-FP](#) [603-JJY-04](#) [604J](#) [604-JJ-05](#)