



FCP Lens series for Cree XP-E and XP-G LEDs

- High efficiency
- 4 beams available
- Easy assembly

The FCP lens offers low-profile lenses specifically designed for the XP-E and XP-G XLamp LEDs from Cree Corporation.

A software-optimized aspheric profile enables the generation of several different beam output patterns: narrow, medium, elliptical, and wide beams.

The high collection efficiency reaches 85% of the total flux emitted by the LEDs.

Lens holders are available in black PC, and provide the proper alignment between the LEDs and the lenses, and set the correct distance between the lens and LED.

The lens holder can be glued and/or screwed to the PCB to provide a secure assembly.

Typical applications are:

- Reading lamps
- Signs
- Architectural Lighting
- Street Lights

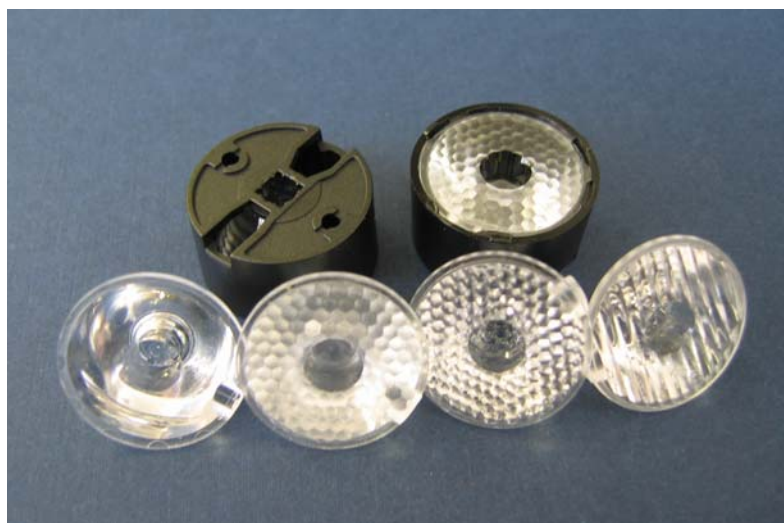

Cree® XLamp is a trademark of Cree, Inc. For technical information about these LEDs please refer to the Cree® XLamp datasheet or visit:

<http://www.cree.com/products/xlamp.asp> .

FRAEN CORPORATION

80 Newcrossing Road
Reading, MA 01867
Phone: 781.205.5300
Fax: 781.942.2426
optics@fraen.com

FRAEN S.r.l.

Via Stelvio, 12
20019 Settimo M. (MI) – Italy
Phone: +39-02-35.456.1
Fax: +39-02-335.456.239
info@fraen.com

Website: www.fraensrl.com

For ordering information, please contact:

NAFTA Countries	ARROW Telephone: 1-888-9LIGHT1 email: lightingsolutions@arrow.com
European Countries	Please contact Fraen S.r.l. for distributor's information Email: info@fraen.com



General Characteristics

Lens Material	Optical Grade PMMA
Holder Material	PC, black color
Operating Temperature range	-40deg C / + 80 deg C
Storage Temperature range	-40deg C / + 80 deg C

Average transmittance in visible spectrum (400 – 700nm) >90%, as measured using 3mm thick Optical Grade PMMA.

Please note that flow lines and weld lines on the external surfaces of the lenses are acceptable if the optical performance of the lens is within the specification described in the section “OPTICAL CHARACTERISTICS”.

IMPORTANT NOTE – Lenses handling and cleaning:

- *Handling: Always use gloves to handle lenses and/or handle the lenses only by the flange. Never touch the outside surfaces of the lenses with fingers; finger oils and contamination will absorb or refract light.*
- *Cleaning: Clean lenses only if necessary. Use only soap and water to clean the surfaces and lenses. Never expose the lenses to solvents such as alcohol, as it will damage the plastic.*

Scope

This datasheet provides information about the FCP series lenses:

- FCP-N1-XPE1-0R
- FCP-M1-XPE1-0R
- FCP-W1-XPE1-0R
- FCP-E1-XPE1-0R

and lens assemblies:

- FCP-N1-XPE1-HRF
- FCP-M1-XPE1-HRF
- FCP-W1-XPE1-HRF
- FCP-E1-XPE1-HRF

These lenses and assemblies may be used on either the Cree XP-E or XP-G LEDs.



Optical Characteristics – Beam Angle (degrees, full-angle half-maximum)

Lens Part Number	Beam Output	XP-E	XP-G
FCP-N1-XPE1-0R	Narrow beam	10	13
FCP-M1-XPE1-0R	Medium beam	21	21
FCP-W1-XPE1-0R	Wide beam	39	38
FCP-E1-XPE1-0R	Elliptical beam	10 x 44	13 x 43

- (1) The typical divergence varies with LED color due to different chip size and chip position tolerance. The typical total divergence is the full angle measured where the luminous intensity is half of the peak value.

Optical Characteristics – On-Axis Intensity (candela/lumen)

Lens Part Number	Beam Output	XP-E	XP-G
FCP-N1-XPE1-0R	Narrow beam	23	13
FCP-M1-XPE1-0R	Medium beam	4.4	4.2
FCP-W1-XPE1-0R	Wide beam	1.9	1.8
FCP-E1-XPE1-0R	Elliptical beam	4.9	4.1

- (2) To calculate the on-axis intensity, multiply the on-axis efficiency of the lens (cd/lm) by the total flux of the Cree XP-E and XP-G XLamp LED used. See "Illumination Calculations" below. For more detail on flux ranking (binning) please check the XP-E and XP-G XLamp LED datasheet at http://www.cree.com/products/xlamp_xpe.asp or http://www.cree.com/products/xlamp_xpg.asp
- (3) Luminous intensity depends on the flux binning and tolerances of the LEDs. Please refer to the Cree XP-E and XP-G XLamp LED datasheet for more details on flux ranking and mechanical tolerances.
- (4) Typical illuminance measured in lux per lumen (E) with typical XP-E and XP-G LEDs. To estimate the illuminance in lux, multiply the typical illuminance E by the flux in lumen of the LED used. See "Illumination Calculations" below.

Illumination Calculations

To calculate peak candela: Find the central spot “on-axis intensity” value in the table above, then multiply this value by the lumens output from your LED (refer to the Cree XP-E and XP-G LED datasheet (<http://www.cree.com/products/xlamp.asp>) for nominal lumens values. OR for a more accurate calculation, refer to the intensity “ranking” (binning) tables on the datasheet for the specific LED.

Example calculations:

If the Fraen narrow beam lens FCP-N1-XPE1-0R is used on a cool white Cree XP-E LED at 350 mA, the typical luminous flux of the LED is 100 lumens:

The calculation is: (23 candela/lumen) x (100 lumens) = 2300 candela peak on-axis.

The beam angle specified in the table above is 13 degrees full beam-width measured at half-peak.

This means at 6.5 degrees off-axis (half of 13 degrees), the intensity should be half of 2300 candela, or 1150 candelas.

1 candela at 1-meter distance produces 1 Lux. This means the peak intensity at 1 meter will be 2300 lux. The intensity decreases as a function of the distance squared, so at 2 meters the peak intensity will be $2300 / (2^2) = 575$ lux. At 3 meters distance, the peak intensity will be $2300 / (3^2) = 256$ lux.

Mechanical Characteristics

FCP-N1-XPE1-0R
Narrow Beam

FCP-M1-XPE1-0R
Medium Beam

FCP-W1-XPE1-0R
Wide Beam

FCP-E1-XPE1-0R
Elliptical Beam

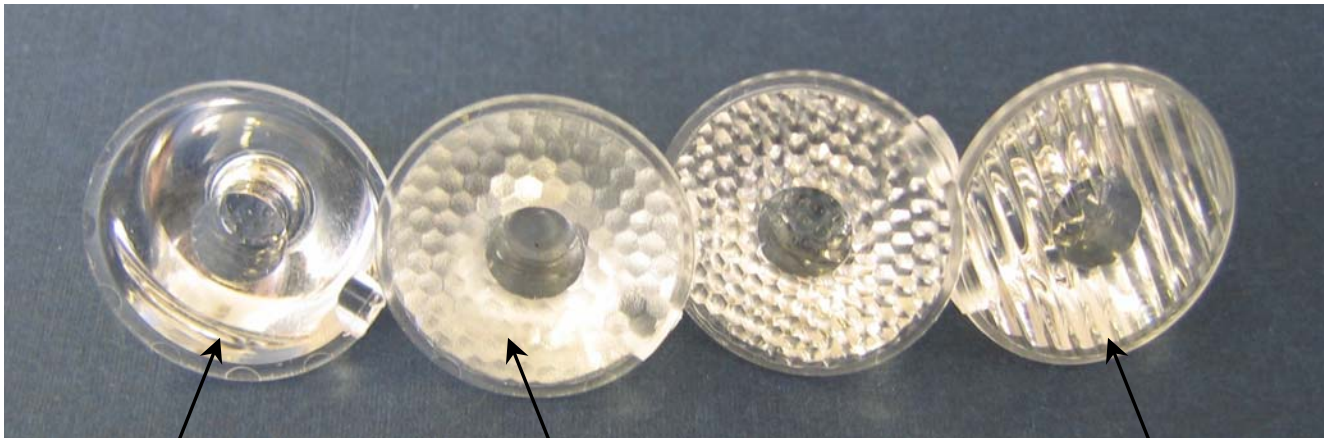

The narrow beam lens has flat polished face (no microlenses).

The medium beam lens (only) has a light texture on the microlenses.

The elliptical beam lens has rib microlenses.

Figure 1. Identifying the FCP series lenses by their front appearance.



The FCP series lenses are available either assembled to a holder or without a holder. The holder provides the correct alignment (concentricity, height, and orientation) of the lens to the LED. Orientation control is important for the elliptical beam lens.

NOTE: If the FCP lens is used with no lens holder, the user must provide a mechanical method to set the correct position of the lens on the LED. For example, the lens flange can be located in the lamp housing to center the lens to the LED and establish 10.8 mm from the lens flange to the user's PC board. When the lens is positioned correctly, the bottom of the lens should be even with the top of the square LED substrate.

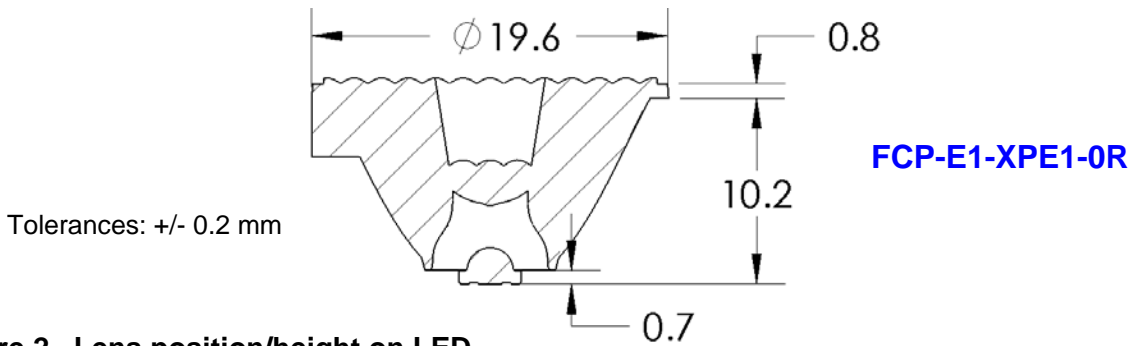
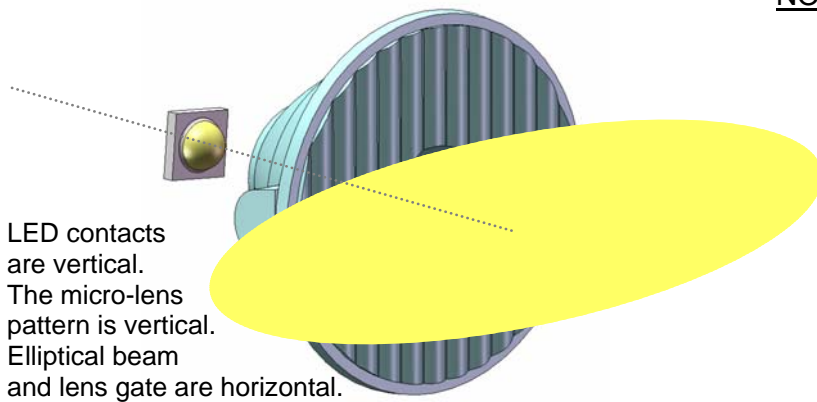

Figure 2. Lens position/height on LED



NOTE: The elliptical beam lens produces a beam shape that is perpendicular to the microlens pattern on the output face of the lens. The lens holder is designed to align the elliptical pattern with the square shape of the Cree LED and contacts orientation. It is important to consider the orientation of the LEDs and the desired elliptical beam orientation when designing the printed circuit board layout.

For example, to produce a horizontal elliptical beam the lens needs to be orientated such that the micro-lenses are positioned vertically. The elliptical beam lens assembly (with holder) will only fit the Cree LED in this orientation (with elliptical beam perpendicular to the orientation of the LED contacts). The LED orientation on the PC board should be coordinated with the beam orientation.

Figure 3. Orientation of elliptical beam

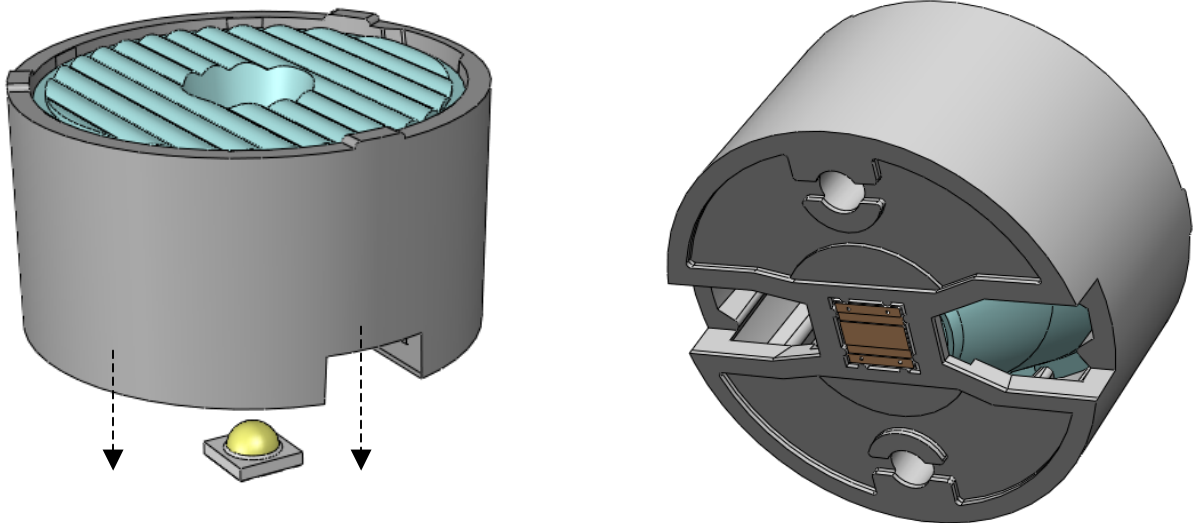

The FCP-E1-XPE1-HRF (and N1, M1 and W1) lens assemblies will fit onto the Cree LED at only 2 orientations: 0 degrees and 180 degrees. The bottom of this –HRF lens holder has a square shape to control lens orientation (important for “E1” elliptical beam lens application). After installation, the bottom of the holder should be at the same datum/plane as the bottom of the Cree LED.

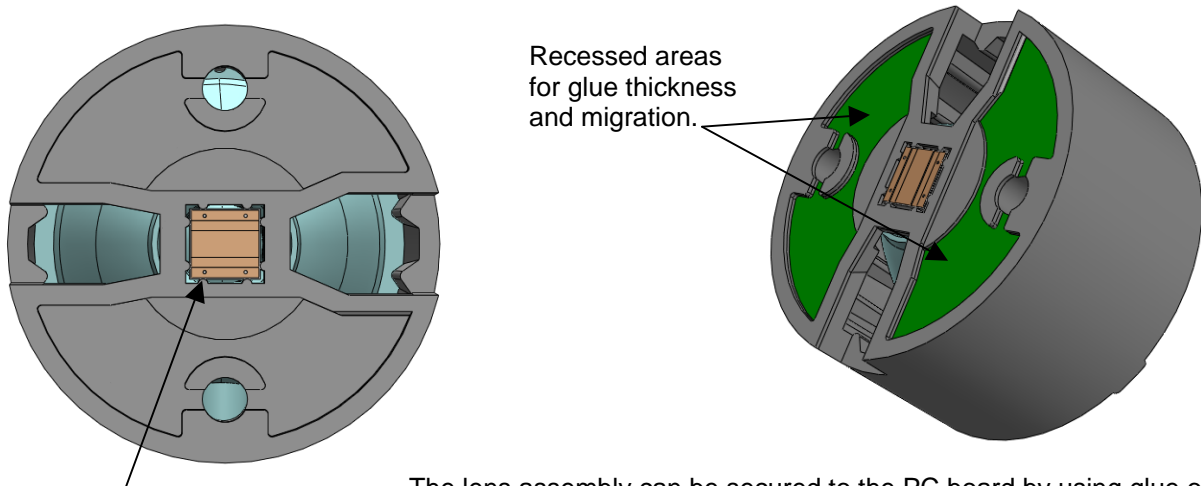

The LED package will fit into the square hole in the lens holder. This will align the lens to the LED.

The lens assembly can be secured to the PC board by using glue or silicone RTV. To avoid glue on the lens and LED, apply it along the outside diameter edge, or apply a very thin film on areas shown above in green.

CAUTION: Do not use “instant” glue (containing cyanoacrylates). Always test the glue on a sample assembly and check the results and performance 24 hours later. Some adhesives produce fumes that will damage the surfaces of the plastic lens, lens holder, or LED.

Figure 4. Installation of lens assembly onto Cree XP-E or XP-G LED

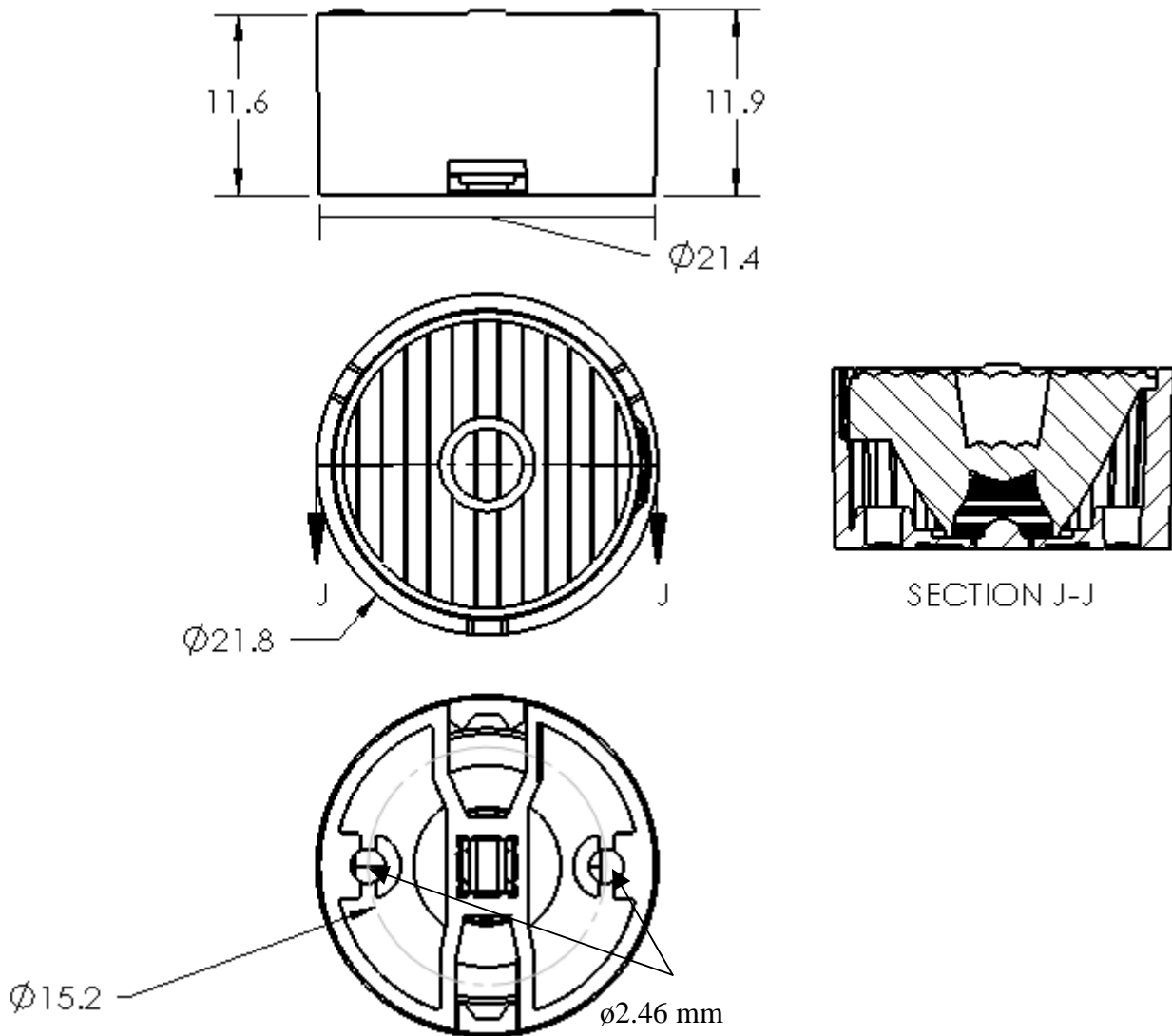

Figure 5. Overall dimensions of FCP-1-XPE1-HRF series lens assemblies



Ordering part numbers

FCP- _1-XPE1- _____

0R: Lens alone (no holder)
 HRF: Lens with black PC holder

Caution: If using lens alone (with no holder), lens alignment and spacing must be set by the user (see Figure 3).

N: Narrow beam
 M: Medium beam
 W: Wide beam
 E: Elliptical beam

Caution: The orientation of the elliptical beam lens is controlled by the lens holder and the LED orientation (see Figures 3 and 4).

Part Number Examples:

FCP-M1-XPE1-0R = medium beam lens without lens holder.

FCP-E1-XPE1-HRF = lens assembly - elliptical beam lens heat-staked into lens holder.

Published by Fraen Corporation.

All data contained in this document is the property of Fraen Corporation and may change without notice.

Rev	Date	Author	Description
01	06 October 2009	C. Jones	7 pages of text and data added. XP-G LED added.
00	16 September 2008	C. Jones	Initial Release.

X-ON Electronics

Largest Supplier of Electrical and Electronic Components

Click to view similar products for IMUs - Inertial Measurement Units category:

Click to view products by Fraen manufacturer:

Other Similar products are found below :

[LSM6DSLUSTR](#) [ADIS16507-1/PCBZ](#) [ADIS16507-2/PCBZ](#) [FCP-E1-XPE1-HRF](#) [MTi-10-2A8G4](#) [ADIS16477-2BMLZ](#) [MTi-20-2A8G4](#)
[ADIS16497-3BMLZ](#) [MTi-30-2A8G4](#) [ADIS16475-2BMLZ](#) [ICM-20649](#) [ICM-20948](#) [ICM-30670](#) [ADIS16497-1BMLZ](#) [ICM-20789](#) [ICM-](#)
[20602](#) [ICM-20601](#) [IMU381ZA-200](#) [IMU383ZA-400](#) [MTLT305D](#) [OpenIMU300RI](#) [OpenIMU300ZI](#) [OpenIMU330BI](#) [4464](#) [4480](#) [4485](#) [4502](#)
[4517](#) [ADIS16364BMLZ](#) [ADIS16365BMLZ](#) [ADIS16445BMLZ](#) [ADIS16465-3BMLZ](#) [ADIS16467-1BMLZ](#) [ADIS16467-2BMLZ](#)
[ADIS16467-3BMLZ](#) [ADIS16470AMLZ](#) [ADIS16475-3BMLZ](#) [ADIS16477-3BMLZ](#) [ADIS16495-1BMLZ](#) [ADIS16495-2BMLZ](#) [ADIS16497-](#)
[2BMLZ](#) [ADIS16507-3BMLZ](#) [ADIS16505-1BMLZ](#) [SHUTTLE BOARD BNO055](#) [BHI160](#) [BHI160B](#) [BMF055](#) [SEN0374](#) [TARS-HCASS](#)
[MM8003](#)