



## FCT3 Series Tri-Lens for Cree XLamp® 7090 XR and XR-E LEDs

- High efficiency
- 3 beams available
- MR-16 size tri-lens

The FCT3 tri-lens offers low-profile lenses specifically designed for the XLamp® 7090XR and XR-E LEDs <sup>(1)</sup> from Cree.

A software-optimized aspheric profile enables the generation of three different beam output patterns: narrow, medium, and wide beams.

The high collection efficiency reaches 85% of the total flux emitted by the LEDs.

Lens holders are black polycarbonate, and provide the proper alignment between the LEDs and the lenses, and set the correct distance between the lens and LED.

The lens holder can either be heat-staked or mounted with screw to the PCB, to provide a secure assembly.

Typical applications are:

- MR-16 LED lamps
- Architectural lighting
- General illumination
- Street lights

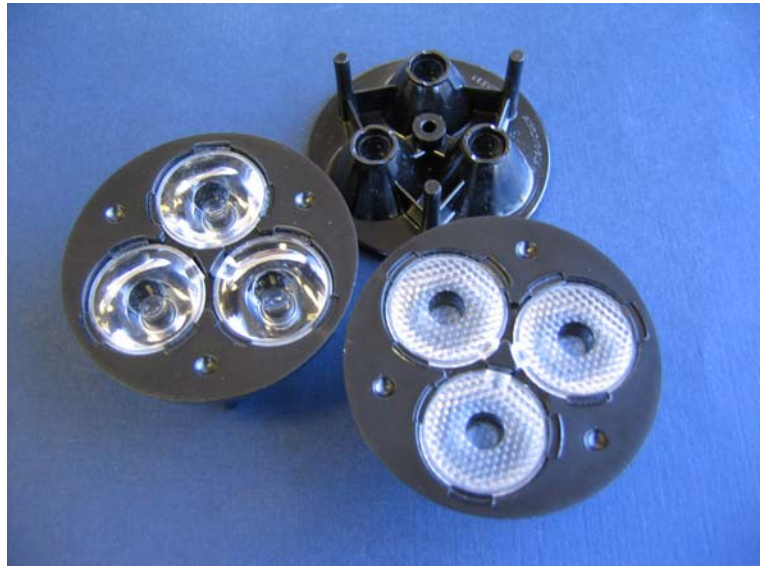

Cree® XLamp is a trademark of Cree, Inc. For technical information about these LEDs please refer to the Cree® XLamp datasheet or visit <http://www.cree.com/products/xlamp.asp> or [http://www.cree.com/products/xlamp7090\\_xre.asp](http://www.cree.com/products/xlamp7090_xre.asp)

### FRAEN CORPORATION

80 Newcrossing Road  
Reading, MA 01867  
Phone: 781.205.5300  
Fax: 781.942.2426  
[optics@fraen.com](mailto:optics@fraen.com)

### FRAEN S.r.l.

Via Stelvio, 12  
20019 Settimo M. (MI) – Italy  
Phone: +39-02-35.456.1  
Fax: +39-02-335.456.239  
[info@fraen.com](mailto:info@fraen.com)

Website: [www.fraensrl.com](http://www.fraensrl.com)

*For ordering information, please contact:*

NAFTA Countries	<b>ARROW</b> Telephone: 1-888-9LIGHT1 email: <a href="mailto:lightingsolutions@arrow.com">lightingsolutions@arrow.com</a>
European Countries	Please contact Fraen S.r.l. for distributor's information Email: <a href="mailto:info@fraen.com">info@fraen.com</a>



## General Characteristics

---

Lens Material	Optical Grade PMMA
Holder Material	PC, black color
Operating Temperature range	-40deg C / + 80 deg C
Storage Temperature range	-40deg C / + 80 deg C

Average transmittance in visible spectrum (400 – 700nm) >90%, as measured using 3mm thick Optical Grade PMMA.

*Please note that flow lines and weld lines on the external surfaces of the lenses are acceptable if the optical performance of the lens is within the specification described in the section "OPTICAL CHARACTERISTICS"*

### **IMPORTANT NOTE – Lenses handling and cleaning:**

- *Handling: Always use gloves to handle lenses and/or handle the lenses only by the flange. Never touch the outside surfaces of the lenses with fingers; finger oils and contamination will absorb or refract light.*
- *Cleaning: Clean lenses only if necessary. Use only soap and water to clean the surfaces and lenses. Never expose the lenses to solvents such as alcohol, as it will damage the plastic.*

## Scope

---

This datasheet provides information about the three FCT3 series tri-lenses with a screw tower (column) on the holder:

- FCT3-N2-XR79-HRLC
- FCT3-M2-XR79-HRLC
- FCT3-W2-XR79-HRLC

and the three FCT3 series tri-lenses without a screw tower on the holder:

- FCT3-N2-XR79-HRLN
- FCT3-M2-XR79-HRLN
- FCT3-W2-XR79-HRLN



## Optical Characteristics – Beam Angle (degrees, full angle)

Lens Part Number	Output Beam	Cool White ○	Warm White ○	Blue ●	Green ●	Red ●
FCT3-N2-XR79-HRLC	Narrow	8	8	12	12	12
FCT3-M2-XR79-HRLC	Medium	21	20	22	22	22
FCT3-W2-XR79-HRLC	Wide	29	28	28	28	28

(1) The typical divergence varies with LED color due to different chip size and chip position tolerance. The typical total divergence is the full angle measured where the luminous intensity is half of the peak value.

## Optical Characteristics – On-Axis Intensity (candela/lumen)

Lens Part Number	Output Beam	Cool White ○	Warm White ○	Blue ●	Green ●	Red ●
FCT3-N2-XR79-HRLC	Narrow	27	27	18	18	19
FCT3-M2-XR79-HRLC	Medium	4.1	4.1	2.9	2.9	3.3
FCT3-W2-XR79-HRLC	Wide	2.4	2.4	1.9	1.9	2.4

- (2) To calculate the on-axis intensity, multiply the on-axis efficiency of the lens (cd/lm) by the total flux of the Cree XLamp 7090® XR and XR-E LED used. See “Illumination Calculations” below. For more detail on flux binning please check the Cree LED datasheet at <http://www.cree.com/products/xlamp.asp>
- (3) Luminous intensity depends on the flux binning and tolerances of the LEDs. Please refer to the Cree XLamp datasheet for more details on flux binning and mechanical tolerances.
- (4) Typical illuminance measured in lux per lumen (E) with typical Cree 7090 XR-E LED. To estimate the illuminance in lux, multiply the typical illuminance E by the flux in lumen of the LED used. See “Illumination Calculations” below.

Please see the next page for illumination calculations.



## Illumination Calculations

To calculate peak candela: Find the central spot “on-axis intensity” value in the table above, then multiply this value by the lumens output from your LED (refer to the Cree LED datasheet <http://www.cree.com/products/pdf/XLamp7090XR-E.pdf> or <http://www.cree.com/products/pdf/XLamp7090XR.pdf> for nominal lumens values). Or for a more accurate calculation, refer to the intensity binning tables [http://www.cree.com/products/xlamp\\_docs.asp](http://www.cree.com/products/xlamp_docs.asp) .

### Example calculations:

If the Fraen narrow beam tri-lens FCT3-N2-XR79-HRLC is used on 3 cool white Cree XR-E LEDs at 350 mA, the typical luminous flux of the LED is 80 lumens:

The calculation is: (27 candela/lumen) x (80 lumens) = 2160 candela peak on-axis. For three 80 lumen LEDs and a tri-lens: 2160 x 3 = 6480 candela peak on-axis.

1 candela at 1-meter distance produces 1 Lux. This means the peak intensity from this tri-lens at 1 meter will be 6480 lux. The intensity decreases as a function of the distance squared, so at 2 meters the peak intensity will be  $6480 / (2^2) = 1620$  lux. At 3 meters distance, the peak intensity will be  $6480 / (3^2) = 720$  lux.

The beam angle specified in the table above is 8 degrees full beam-width measured at half-peak. This means at 4 degrees off-axis (half of 8 degrees), the intensity should be half of 6480 candela, or 3240 candelas.

## Mechanical Characteristics

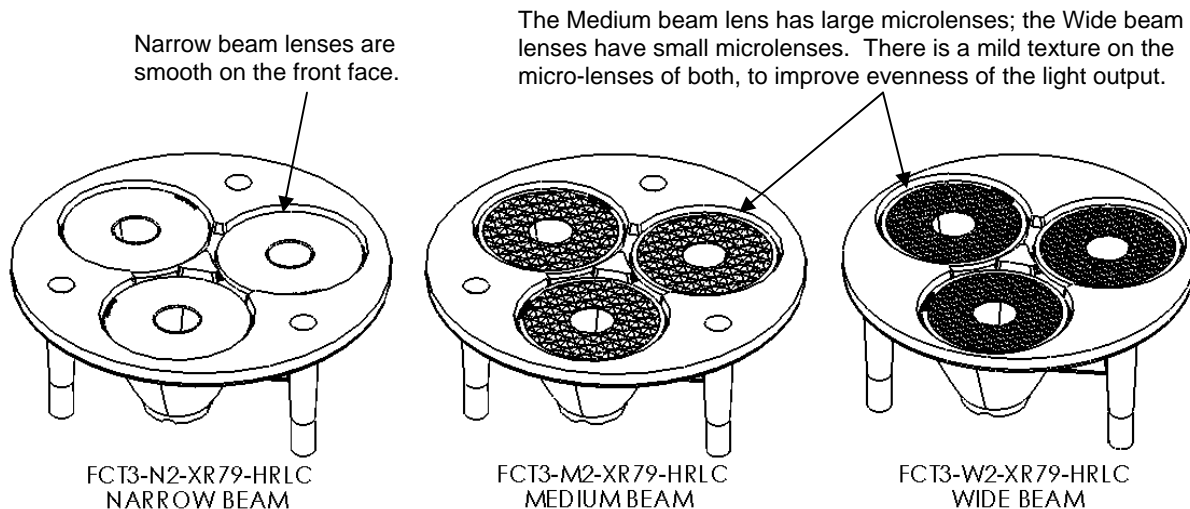
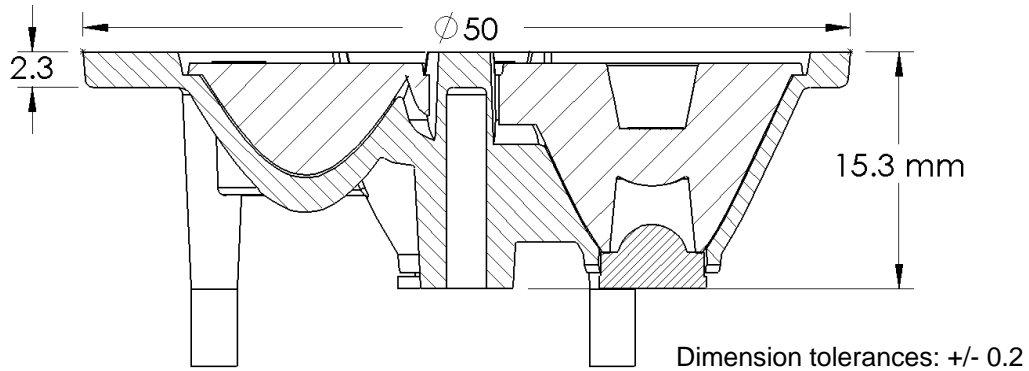

Figure 1: The tri-lens assemblies can be identified by the front face surfaces of the lenses.

The FCT3 series tri-lenses are available only assembled to a holder. The holder provides the correct alignment (concentricity, height, and alignment) of the lens to the LED.



NOTE: The dimension “15.3mm” represents the distance from the top of the lens holder (excluding heat stake marks) to the bottom of the Cree LEDs. For the tri-lens assemblies with part number suffix –HRLC, the screw column is designed to touch the circuit board, and there is a hole 2.6 mm diameter x ~12 mm deep to accept a self-threading screw. The tri-lens assemblies with part number suffix –HRLN have a shortened screw column height (only 11mm) to provide clearance for circuit components or hardware, if a screw mounting is not employed.

Figure 2: X-section view shows the lens touches the Cree XR/XR-E LED, and the holder aligns the lens to the LED.

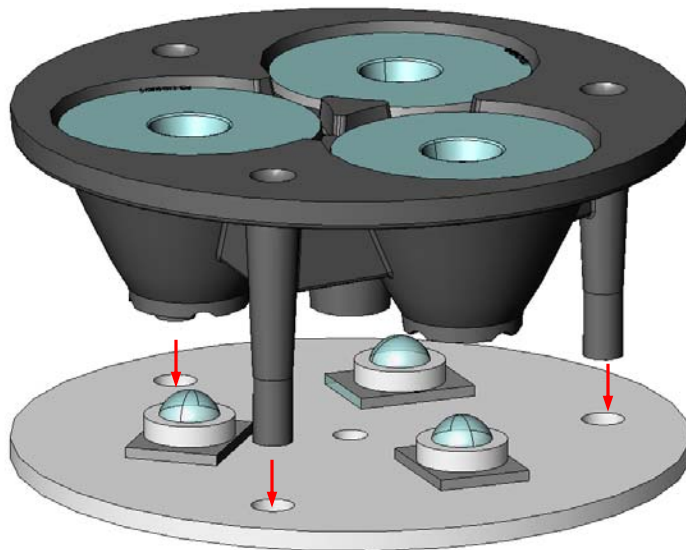

Figure 3: The 3 legs on the tri-lens require clearance holes in the circuit board. The holder has a ring feature around each lens, to align the holder to the LEDs.

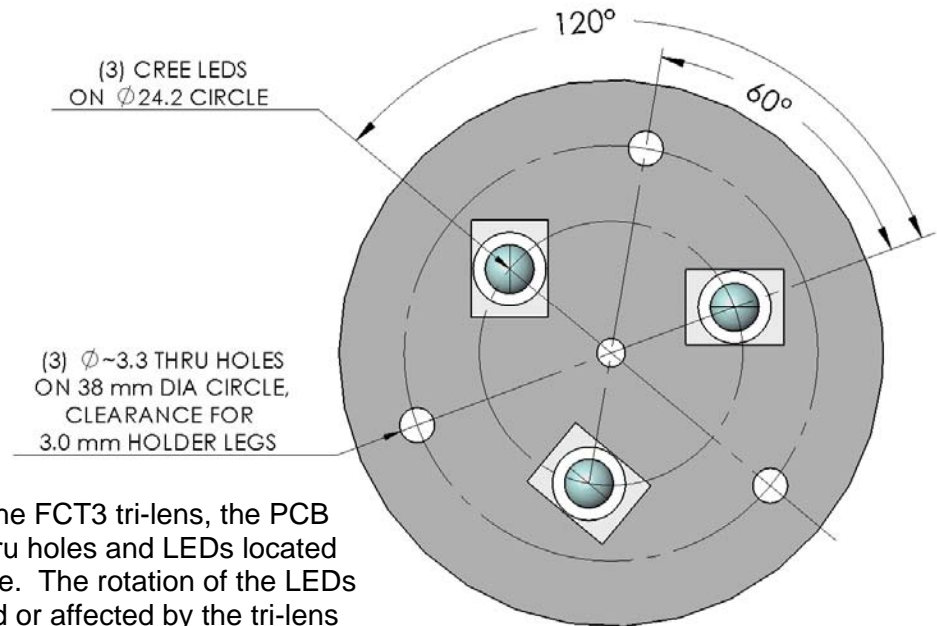

Figure 4: For best fit to the FCT3 tri-lens, the PCB should have thru holes and LEDs located as shown above. The rotation of the LEDs is not controlled or affected by the tri-lens holder, and can be decided by the user.

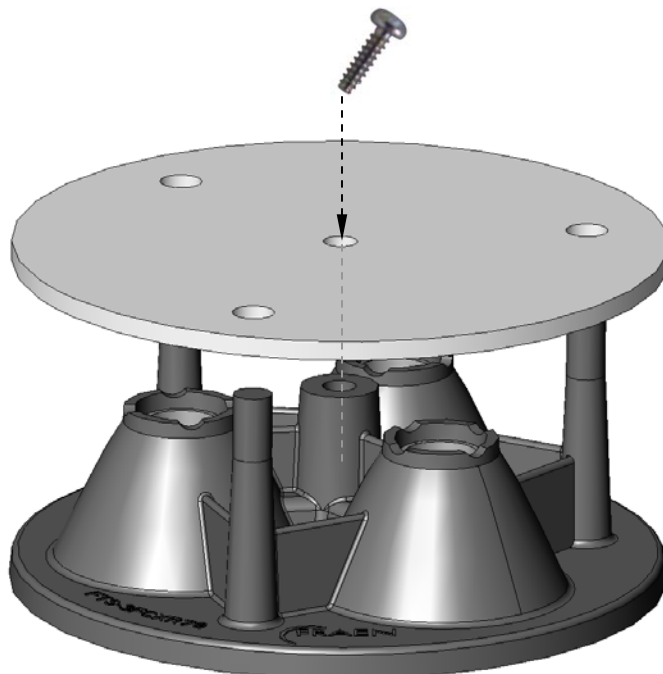

Figure 5: A thread-forming or thread-rolling screw (size: #4-24) can be used to secure the circuit board to the Fraen tri-lens assembly (use tri-lens assemblies with p/n suffix -HRLC). Alternatively, the 3 legs on the holder can be heat staked or glued on the back of the circuit board. For general information about heat staking, see Fraen Application Note: [http://www.fraensrl.com/images/FRN\\_FHSLenses\\_HeatStake.pdf](http://www.fraensrl.com/images/FRN_FHSLenses_HeatStake.pdf)



## Ordering part numbers

---

FCT3-\_\_-XR79-HRL\_\_

C: holder has screw column  
N: no screw column  
(See Figure 1 and "Note")

N2: Narrow beam  
M2: Medium beam  
W2: Wide beam

*Published by Fraen Corporation.  
All data contained in this document is the property of Fraen Corporation and may change without notice.*

Rev	Date	Author	Description
01	18-April-2008	C. Jones	Added Figure 4
00	25-March-2008	C. Jones	Initial Release

## X-ON Electronics

Largest Supplier of Electrical and Electronic Components

*Click to view similar products for IMUs - Inertial Measurement Units category:*

*Click to view products by Fraen manufacturer:*

Other Similar products are found below :

[LSM6DSLUSTR](#) [ADIS16507-1/PCBZ](#) [ADIS16507-2/PCBZ](#) [FCP-E1-XPE1-HRF](#) [MTi-10-2A8G4](#) [ADIS16477-2BMLZ](#) [MTi-20-2A8G4](#)  
[ADIS16497-3BMLZ](#) [MTi-30-2A8G4](#) [ADIS16475-2BMLZ](#) [ICM-20649](#) [ICM-20948](#) [ICM-30670](#) [ADIS16497-1BMLZ](#) [ICM-20789](#) [ICM-](#)  
[20602](#) [ICM-20601](#) [IMU381ZA-200](#) [IMU383ZA-400](#) [MTLT305D](#) [OpenIMU300RI](#) [OpenIMU300ZI](#) [OpenIMU330BI](#) [4464](#) [4480](#) [4485](#) [4502](#)  
[4517](#) [ADIS16364BMLZ](#) [ADIS16365BMLZ](#) [ADIS16445BMLZ](#) [ADIS16465-3BMLZ](#) [ADIS16467-1BMLZ](#) [ADIS16467-2BMLZ](#)  
[ADIS16467-3BMLZ](#) [ADIS16470AMLZ](#) [ADIS16475-3BMLZ](#) [ADIS16477-3BMLZ](#) [ADIS16495-1BMLZ](#) [ADIS16495-2BMLZ](#) [ADIS16497-](#)  
[2BMLZ](#) [ADIS16507-3BMLZ](#) [ADIS16505-1BMLZ](#) [SHUTTLE BOARD BNO055](#) [BHI160](#) [BHI160B](#) [BMF055](#) [SEN0374](#) [TARS-HCASS](#)  
[MM8003](#)