



FNP Lens series for Nichia NS6x083T LEDs

- High efficiency
- 4 beams available
- Easy assembly

The FNP lens offers low-profile lenses specifically designed for the NS6x083T Power LEDs from Nichia Corporation.

A software-optimized aspheric profile enables the generation of several different beam output patterns: narrow, medium, elliptical, and wide beams.

The high collection efficiency reaches 85% of the total flux emitted by the LEDs.

Lens holders are available in black PC, and provide the proper alignment between the LEDs and the lenses, and set the correct distance between the lens and LED.

The lens holder can be glued and/or screwed to the PCB to provide a secure assembly.

Typical applications are:

- Reading lamps
- Signs
- Architectural Lighting
- Street Lights



For technical information about Nichia NS6x083T LEDs please refer to the Nichia Power LEDs datasheet web-link:

<http://www.nichia.com/product/led-smd-powerled.html>

FRAEN CORPORATION

80 Newcrossing Road
Reading, MA 01867
Phone: 781.205.5300
Fax: 781.942.2426

optics@fraen.com

FRAEN S.r.l.

Via Stelvio, 12
20019 Settimo M. (MI) – Italy
Phone: +39-02-35.456.1
Fax: +39-02-335.456.239

info@fraen.com

Website: www.fraensrl.com

For ordering information, please contact:

NAFTA Countries	ARROW Telephone: 1-888-9LIGHT1 email: lightingsolutions@arrow.com
European Countries	Please contact Fraen S.r.l. for distributor's information Email: info@fraen.com



General Characteristics

Lens Material	Optical Grade PMMA
Holder Material	PC, black color
Operating Temperature range	-40deg C / + 80 deg C
Storage Temperature range	-40deg C / + 80 deg C

Average transmittance in visible spectrum (400 – 700nm) >90%, as measured using 3mm thick Optical Grade PMMA.

Please note that flow lines and weld lines on the external surfaces of the lenses are acceptable if the optical performance of the lens is within the specification described in the section "OPTICAL CHARACTERISTICS"

IMPORTANT NOTE – Lenses handling and cleaning:

- *Handling: Always use gloves to handle lenses and/or handle the lenses only by the flange. Never touch the outside surfaces of the lenses with fingers; finger oils and contamination will absorb or refract light.*
- *Cleaning: Clean lenses only if necessary. Use only soap and water to clean the surfaces and lenses. Never expose the lenses to solvents such as alcohol, as it will damage the plastic.*

Scope

This datasheet provides information about the FNP series lenses:



- FNP-N1-N083-0R
- FNP-M1-N083-0R
- FNP-W1-N083-0R
- FNP-E1-N083-0R

and lens assemblies:

- FNP-N1-N083-HRF
- FNP-M1-N083-HRF
- FNP-W1-N083-HRF
- FNP-E1-N083-HRF





Optical Characteristics – Beam Angle (degrees, full-angle half-maximum)

Lens Part Number	Beam Output	Cool White 	Warm White 
FNP-N1-N083-0R	Narrow beam	10	10
FNP-M1-N083-0R	Medium beam	27	24
FNP-W1-N083-0R	Wide beam	40	36
FNP-E1-N083-0R	Elliptical beam	13 x 42	13 x 38

- (1) The typical divergence varies with LED color due to different chip size and chip position tolerance. The typical total divergence is the full angle measured where the luminous intensity is half of the peak value.

Optical Characteristics – On-Axis Intensity (candela/lumen)

Lens Part Number	Beam Output	Cool White 	Warm White 
FNP-N1-N083-0R	Narrow beam	10.6	12.1
FNP-M1-N083-0R	Medium beam	3.7	3.9
FNP-W1-N083-0R	Wide beam	1.9	1.9
FNP-E1-N083-0R	Elliptical beam	3.2	3.6

- (2) To calculate the on-axis intensity, multiply the on-axis efficiency of the lens (cd/lm) by the total flux of the Nichia NS6x083T Power LED used. See "Illumination Calculations" below. For more detail on flux ranking (binning) please check the NS6x083T Power LED datasheet at <http://www.nichia.com/product/led-smd-powerled.html>
- (3) Luminous intensity depends on the flux binning and tolerances of the LEDs. Please refer to the Nichia NS6x083T Power LED datasheet for more details on flux ranking and mechanical tolerances.
- (4) Typical illuminance measured in lux per lumen (E) with typical NS6x083T LEDs. To estimate the illuminance in lux, multiply the typical illuminance E by the flux in lumen of the LED used. See "Illumination Calculations" below.



Illumination Calculations

To calculate peak candela: Find the central spot “on-axis intensity” value in the table above, then multiply this value by the lumens output from your LED (refer to the Nichia NS6x083T LED datasheet (<http://www.nichia.com/product/led-smd-poweredled.html>) for nominal lumens values. OR for a more accurate calculation, refer to the intensity “ranking” (binning) tables on the datasheet for the specific LED.

Example calculations:

If the Fraen narrow beam lens FNP-N1-N083-0R is used on a cool white Nichia NS6W083 LED at 300 mA, the typical luminous flux of the LED is 60 lumens:

The calculation is: (10.6 candela/lumen) x (60 lumens) = 636 candela peak on-axis.

The beam angle specified in the table above is 10 degrees full beam-width measured at half-peak.

This means at 5 degrees off-axis (half of 10 degrees), the intensity should be half of 636 candela, or 318 candelas.

1 candela at 1-meter distance produces 1 Lux. This means the peak intensity at 1 meter will be 636 lux. The intensity decreases as a function of the distance squared, so at 2 meters the peak intensity will be $636 / (2^2) = 159$ lux. At 3 meters distance, the peak intensity will be $636 / (3^2) = 71$ lux.

Mechanical Characteristics

Figure 1. Identifying the lenses by their front views

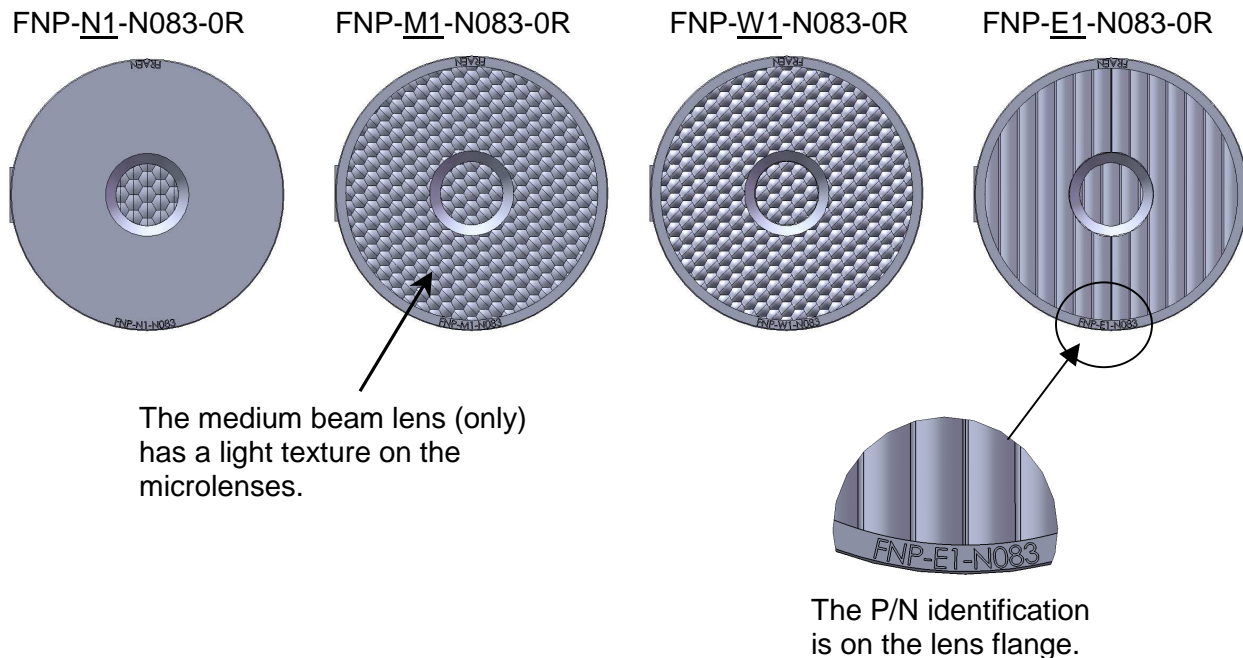



The FNP series lenses are available either assembled to a holder or without a holder. The holder provides the correct alignment (concentricity, height, and orientation) of the lens to the LED. Orientation control is important for the elliptical beam lens.

Figure 2. Correct vertical position of the FNP lens and NS6x083 LED

NOTE: If the FNP lens is used with no lens holder, the user must provide a mechanical method to set the correct position of the lens on the LED. For example, the lens flange can be located in the lamp housing to center the lens to the LED and establish 10.8 mm from the lens flange to the user's PC board. When the lens is positioned correctly, the bottom of the lens touches the LED.

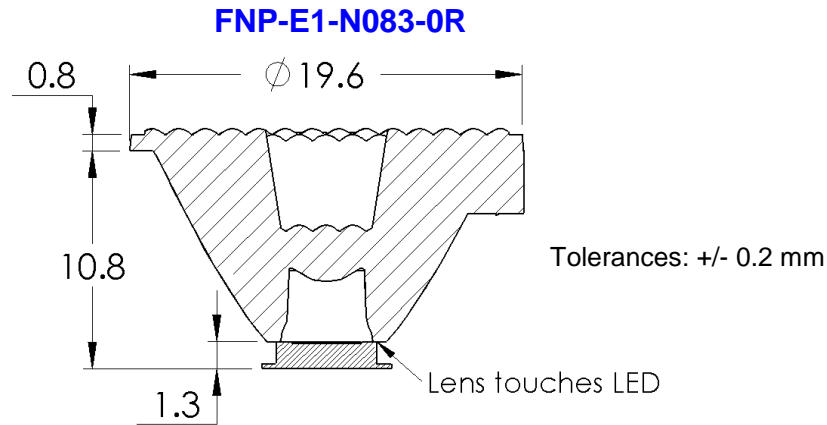
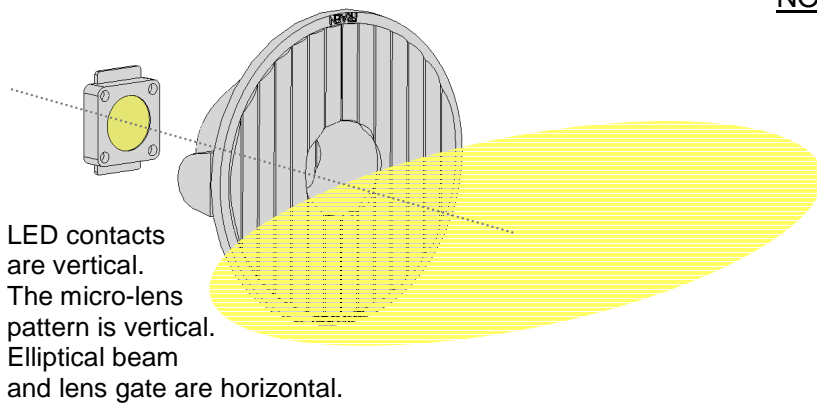

Figure 3. Elliptical beam orientation



NOTE: The elliptical beam lens produces a beam shape that is perpendicular to the microlens pattern on the output face of the lens. The lens holder is designed to align the elliptical pattern with the square shape of the Nichia LED and contacts orientation. It is important to consider the orientation of the LEDs and the desired elliptical beam orientation when designing the printed circuit board layout.

For example, to produce a horizontal elliptical beam the lens needs to be orientated such that the micro-lenses are positioned vertically. The elliptical beam lens assembly (with holder) will only fit the Nichia LED in this orientation (with elliptical beam perpendicular to the orientation of the LED contacts). The LED orientation on the PC board should be coordinated with the beam orientation.

Figure 4. Installation of lens assembly onto Nichia NS6x083 LED

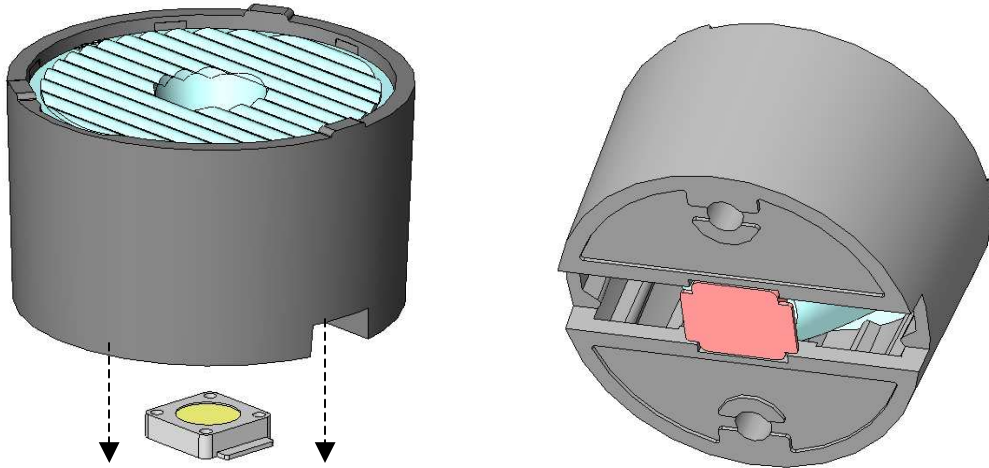

The FNP-E2-N083-HRF (and N1, M1 and W1) lens assemblies will fit onto the Nichia NS6x083 LED at only 2 orientations: 0 degrees and 180 degrees. The bottom of this –HRF lens holder has a square shape to control lens orientation (important for “E1” elliptical beam lens application). After installation, the bottom of the holder should be at the same datum/plane as the bottom of the Nichia LED.

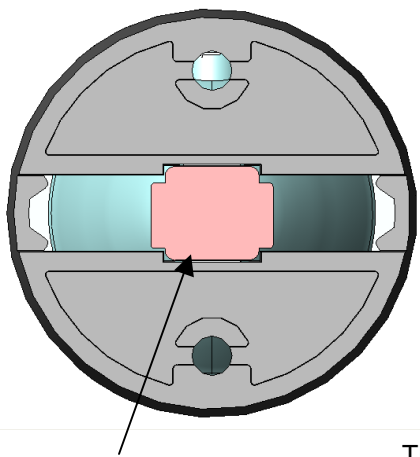

The LED package will fit into the square hole in the lens holder. This will align the lens to the LED.

Recessed areas for glue thickness and migration.

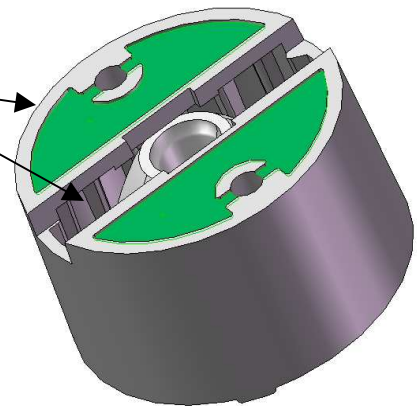

The lens assembly can be secured to the PC board by using glue or silicone RTV. To avoid glue on the lens and LED, apply it along the outside diameter edge, or apply a very thin film on areas shown above in green.

CAUTION: Do not use “instant” glue (containing cyanoacrylates). Always test the glue on a sample assembly and check the results and performance 24 hours later. Some adhesives produce fumes that will damage the surfaces of the plastic lens, lens holder, or LED.

Figure 5. Overall dimensions of FNP- 1-N083-HRF series lens assemblies

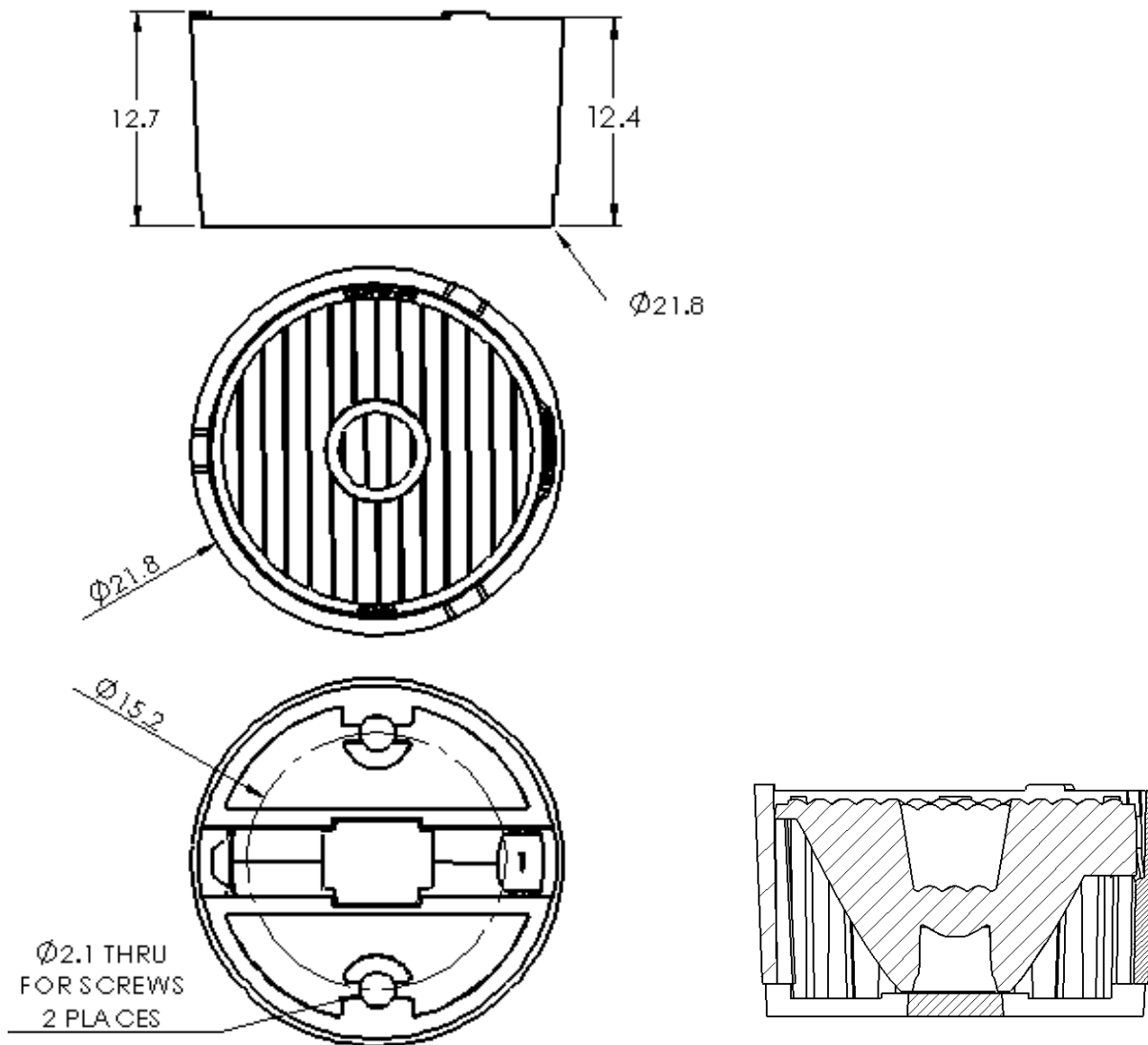



Ordering part numbers

FNP- _1-N083- ____

OR: Lens alone (no holder)
 HRF: Lens with black PC holder

Caution: If using lens alone (with no holder), lens alignment and spacing must be set by the user (see Figure 3).

N: Narrow beam
 M: Medium beam
 W: Wide beam
 E: Elliptical beam

Caution: The orientation of the elliptical beam lens is controlled by the lens holder and the LED orientation (see Figures 3 and 4).

Part Number Examples:

FNP-M1-N083-OR = medium beam lens without lens holder.

FNP-E1-N083-HRF = lens assembly - elliptical beam lens heat-staked into lens holder.

Published by Fraen Corporation.

All data contained in this document is the property of Fraen Corporation and may change without notice.

Rev	Date	Author	Description
00	04 September 2007	C. Jones	Initial Release.
01	09 January 2008	C. Jones	Lens holder option (-HRF) added.

X-ON Electronics

Largest Supplier of Electrical and Electronic Components

Click to view similar products for [Thermostats](#) category:

Click to view products by [Fraen](#) manufacturer:

Other Similar products are found below :

[66F060-0099](#) [66F060-0396](#) [66L085-0477](#) [67F080-0356](#) [67L060-0368](#) [67L080-0038](#) [77877-00](#) [ASP200-22](#) [22636-00](#) [2450 00210626](#) [2450 00880010](#) [2450RC 79080002](#) [2455R--01000844](#) [2455R 80580176](#) [2455R 80820955](#) [2455R 81610172](#) [2455R--90820376](#) [2455RC-00980620](#) [2455RCG81170352](#) [2455RM03090005](#) [2455RM 80820736](#) [2455RM-90980499](#) [2455RP-91000430](#) [2455RP-91000433](#) [2455RP-91000436](#) [2455RP-91000442](#) [300004530001](#) [300100140436](#) [300100630004](#) [3001 00830006](#) [2450G 83950014](#) [2450RC-90820307](#) [2455R--00030829](#) [2455R--01000140](#) [2455R 80820813](#) [2455R 80820815](#) [2455R 81000478](#) [2455R 86890009](#) [2455R--99130436](#) [2455RBV00290011](#) [2455RC-01000545](#) [2455RM 80820767](#) [PN14-6R](#) [300000460015](#) [300005510124](#) [300100240048](#) [310000011390](#) [310000030602](#) [310000031798](#) [310000560067](#)