

1.2 A 15 V H-Bridge motor driver IC

The 17510 is a monolithic H-Bridge designed to be used in portable electronic applications such as digital and SLR cameras to control small DC motors.

The 17510 can operate efficiently with supply voltages as low as 2.0 V to as high as 15 V. Its low $R_{DS(on)}$ H-Bridge output MOSFETs (0.45 Ω typical) can provide continuous motor drive currents of 1.2 A and handle peak currents up to 3.8 A. It is easily interfaced to low-cost MCUs via parallel 5.0 V compatible logic. The device can be pulse width modulated (PWMed) at up to 200 kHz.

This device contains an integrated charge pump and level shifter (for gate drive voltages), integrated shoot-through current protection (cross-conduction suppression logic and timing), and undervoltage detection and shutdown circuitry.

The 17510 has four operating modes: Forward, Reverse, Brake, and Tri-stated (high-impedance). This device is powered by SMARTMOS technology.

Features

- 2.0 V to 15 V continuous operation
- Output current 1.2 A (DC), 3.8 A (peak)
- 450 m Ω $R_{DS(on)}$ H-Bridge MOSFETs
- 5.0 V TTL-/CMOS-compatible inputs
- PWM frequencies up to 200 kHz
- Undervoltage shutdown
- Cross-conduction suppression

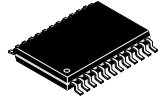
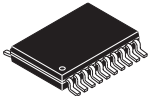
17510	
H-BRIDGE MOTOR DRIVER	
 EJ Suffix (Pb-Free) 98ASH70455A 24-LEAD TSSOP	 EJ Suffix (Pb-Free) 98ASA00887D 20-pin TSSOP with exposed pad

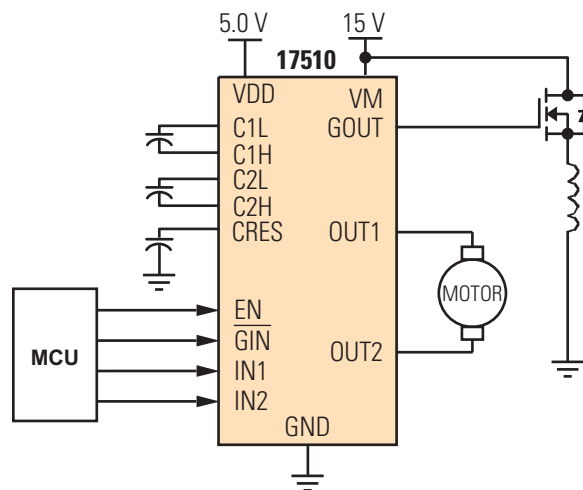

Figure 1. 17510 simplified application diagram

1 Orderable parts

Table 1. Orderable part variations ⁽¹⁾

Part number	Temperature (T _A)	Package
MPC17510AEJ	-30 °C to 65 °C	20 TSSOP (exposed pad)
MPC17510EJ ⁽²⁾		24 TSSOPW

Notes

1. To order parts in Tape & Reel, add the R2 suffix to the part number.
2. Not recommended for new designs.

2 Internal block diagram

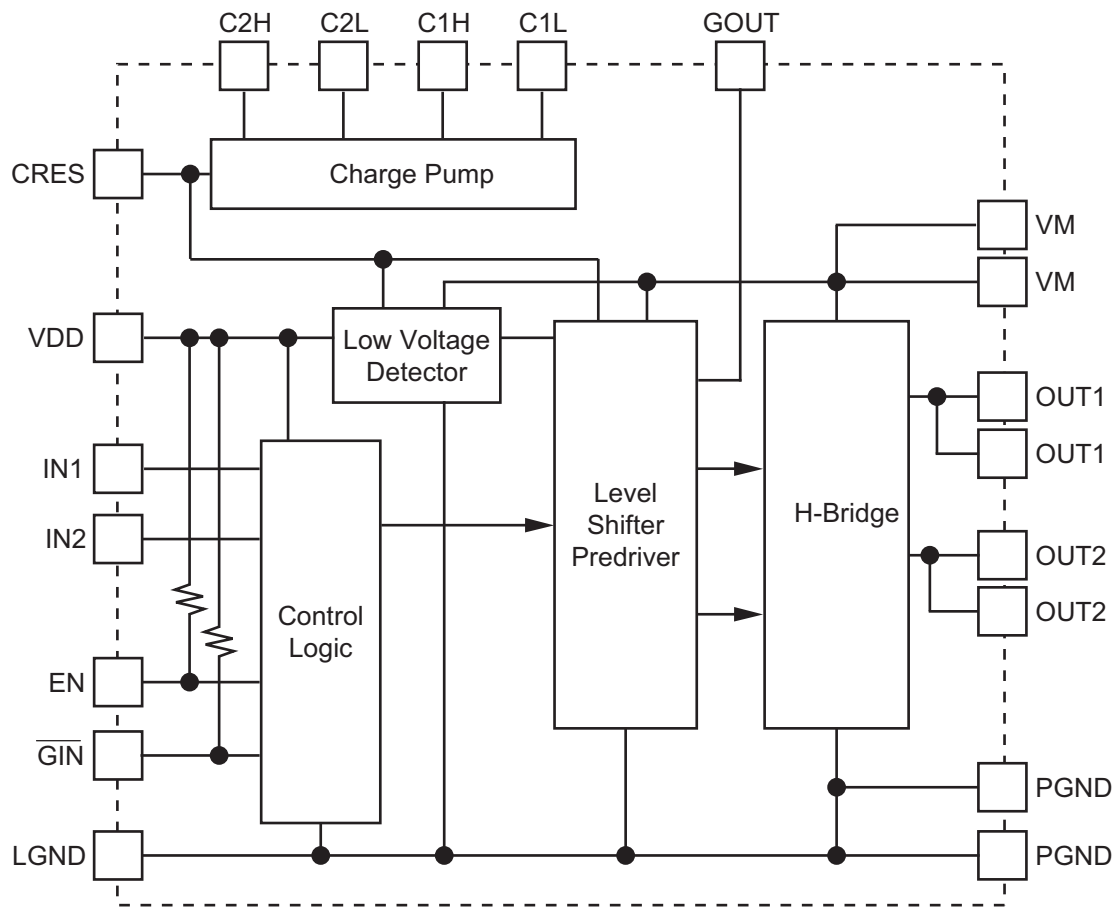

Figure 2. 17510 simplified internal block diagram

3 Pin connections

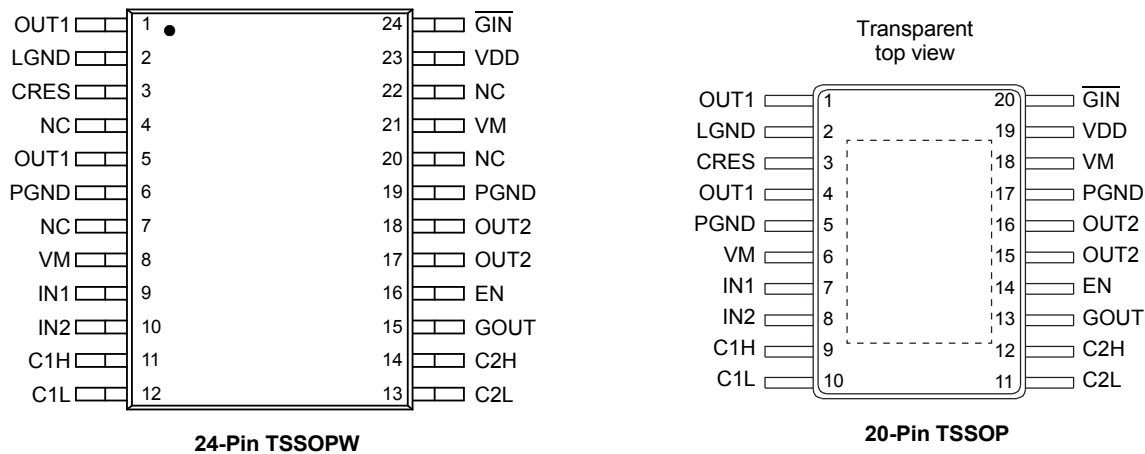

Figure 3. 17510 pin connections

3.1 Pin definitions

A functional description of each pin can be found in the Functional Pin Description section beginning on [page 9](#).

Table 2. 17510 pin definitions

Pin number 24-Pin TSSOPW	Pin number 20-Pin TSSOP	Pin Name	Formal Name	Definition
1, 5	1,4	OUT1	Output 1	Driver output 1 pins
2	2	LGND	Logic Ground	Logic ground
3	3	CRES	Charge Pump Output Capacitor Connection	Charge pump reservoir capacitor pin
4, 7, 20, 22	—	NC	No Connect	No connection to these pins
17, 18	15, 16	OUT2	Output 2	Driver output 2 pins
6, 19	5, 17	PGND	Power Ground	Power ground
8, 21	6, 18	VM	Motor Drive Power Supply	Motor power supply voltage input pins
9	7	IN1	Input Control 1	Control signal input 1 pin
10	8	IN2	Input Control 2	Control signal input 2 pin
11	9	C1H	Charge Pump 1H	Charge pump bucket capacitor 1 (positive pole)
12	10	C1L	Charge Pump 1L	Charge pump bucket capacitor 1 (negative pole)
13	11	C2L	Charge Pump 2L	Charge pump bucket capacitor 2 (negative pole)
14	12	C2H	Charge Pump 2H	Charge pump bucket capacitor 2 (positive pole)
15	13	GOUT	Gate Driver Output	Output gate driver signal to external MOSFET switch
16	14	EN	Enable Control	Enable control signal input pin
23	19	VDD	Logic Supply	Control circuit power supply pin
24	20	GIN	Gate Driver Input	LOW = True control signal for GOUT pin

4 Electrical characteristics

Table 3. Maximum ratings

All voltages are with respect to ground unless otherwise noted. Exceeding these ratings may cause a malfunction or permanent damage to the device.

Symbol	Ratings	Value	Unit	Notes
V_M	Motor Supply Voltage	-0.5 to 16	V	
V_{CRES}	Charge Pump Output Voltage	-0.5 to 13	V	(3)
V_{DD}	Logic Supply Voltage	-0.5 to 16	V	
V_{IN}	Signal Input Voltage (EN, IN1, IN2, \overline{GIN})	-0.5 to $V_{DD}+0.5$	V	
I_O I_{OPK}	Driver Output Current • Continuous • Peak	1.2 3.8	A	(4)
V_{ESD1} V_{ESD2}	ESD Voltage • Human Body Model • Machine Model	± 1900 ± 130	V	(5)
T_{STG}	Storage Temperature	-65 to 150	°C	
T_J	Operating Junction Temperature	-30 to 150	°C	
T_A	Operating Ambient Temperature	-30 to 65	°C	
P_D	Power Dissipation	1.0	W	(6)
$R_{\theta JA}$	Thermal Resistance	120	°C/W	
T_{SOLDER}	Soldering Temperature	260	°C	(7)

Notes

3. When supplied externally, connect via 3.0 k Ω resistor.
4. $T_A = 25$ °C, 10 ms pulse at 200 ms interval.
5. ESD1 testing is performed in accordance with the Human Body Model ($C_{ZAP} = 100$ pF, $R_{ZAP} = 1500$ Ω), ESD2 testing is performed in accordance with the Machine Model ($C_{ZAP} = 200$ pF, $R_{ZAP} = 0$ Ω).
6. $T_A = 25$ °C, $R_{\theta JA} = 120$ °C/W, 37 mm x 50 mm Cu area (1.6 mm FR-4 PCB).
7. Soldering temperature limit is for 10 seconds maximum duration. Not designed for immersion soldering. Exceeding these limits may cause malfunction or permanent damage to the device.

4.1 Static electrical characteristics

Table 4. Static electrical characteristics

Characteristics noted under conditions $T_A = 25\text{ }^\circ\text{C}$, $V_M = 15\text{ V}$, $V_{DD} = 5.0\text{ V}$, $GND = 0\text{ V}$, unless otherwise noted. Typical values noted reflect the approximate parameter means at $T_A = 25\text{ }^\circ\text{C}$ under nominal conditions, unless otherwise noted.

Symbol	Characteristic	Min.	Typ.	Max.	Unit	Notes
Power						
V_M	Motor Supply Voltage	2.0	–	15	V	
V_{DD}	Logic Supply Voltage	4.0	–	5.5	V	
C1, C2, C3	Capacitor for Charge Pump	0.001	–	0.1	μF	
I_{VMSTBY} $I_{VDDSTBY}$	Standby Power Supply Current • Motor Supply Standby Current • Logic Supply Standby Current	–	–	1.0	μA	(8)
I_{VDD}	Logic Supply Current	–	3.3	4.0	mA	(9)
V_{DDDET} V_{MDET}	Low Voltage Detection Circuit • Detection Voltage (V_{DD}) • Detection Voltage (V_M)	1.5 4.0	2.5 5.0	3.5 6.0	V	(10)
$R_{DS(on)}$	Driver Output ON Resistance • $V_M = 2.0\text{ V}, 8.0\text{ V}, 15\text{ V}$	–	0.45	0.55	W	(11)
Gate drive						
V_{CRES}	Gate Drive Voltage • No Current Load	12	13	13.5	V	(12)
$V_{CRESLOAD}$	Gate Drive Ability (Internally Supplied) • $I_{CRES} = -1.0\text{ mA}$	10	11.2	–	V	
$V_{GOUTHIGH}$ $V_{GOUTLOW}$	Gate Drive Output • $I_{OUT} = -50\text{ }\mu\text{A}$ • $I_{IN} = 50\text{ }\mu\text{A}$	$V_{CRES} - 0.5$ LGND	$V_{CRES} - 0.1$ LGND + 0.1	V_{CRES} LGND + 0.5	V	
Control logic						
V_{IN}	Logic Input Voltage (EN, IN1, IN2, \overline{GIN})	0.0	–	V_{DD}	V	
V_{IH} V_{IL} I_{IH} I_{IL} I_{IL}	Logic Input Function ($4.0\text{ V} < V_{DD} < 5.5\text{ V}$) • High Level Input Voltage • Low Level Input Voltage • High Level Input Current • Low Level Input Current • EN/ \overline{GIN} Pin	$V_{DD} \times 0.7$ – – –1.0 –200	– – – – –50	– $V_{DD} \times 0.3$ 1.0 – –	V V μA μA μA	

Notes

8. Excluding pull-up resistor current, including current of gate-drive circuit.
9. $f_{IN} = 100\text{ kHz}$.
10. Detection voltage is defined as when the output becomes high-impedance after V_{DD} drops below the detection threshold. When the gate voltage V_{CRES} is applied from an external source, $V_{CRES} = 7.5\text{ V}$.
11. $I_O = 1.2\text{ A}$ source + sink.
12. Input logic signal not present.

4.2 Dynamic electrical characteristics

Table 5. Dynamic electrical characteristics

Characteristics noted under conditions $T_A = 25\text{ }^\circ\text{C}$, $V_M = 15\text{ V}$, $V_{DD} = 5.0\text{ V}$, $GND = 0\text{ V}$ unless otherwise noted. Typical values noted reflect the approximate parameter means at $T_A = 25\text{ }^\circ\text{C}$ under nominal conditions unless otherwise noted.

Symbol	Characteristic	Min.	Typ.	Max.	Unit	Notes
Input (EN, IN1, IN2, GIN)						
f_{IN}	Pulse Input Frequency	–	–	200	kHz	
t_R	Input Pulse Rise Time	–	–	1.0 ⁽¹⁴⁾	μs	(13)
t_F	Input Pulse Fall Time	–	–	1.0 ⁽¹⁴⁾	μs	(15)
Output						
t_{PZH} t_{PLH} t_{PHL}	Propagation Delay Time • Turn-ON Time • Turn-ON Time • Turn-OFF Time	–	0.3 1.2 0.5	1.0 2.0 1.0	μs	
t_{TON} t_{TOFF}	GOUT Output Delay Time • Turn-ON Time • Turn-OFF Time	–	–	10 10	μs	(16)
f_{OSC} $t_{VCRESON}$	Charge Pump Circuit • Oscillator Frequency • Rise Time	100	200 0.1	400 1.0	kHz ms	(17)
t_{VDDDET}	Low-voltage Detection Time	–	–	10	ms	

Notes

13. Time is defined between 10% and 90%.
14. That is, the input waveform slope must be steeper than this.
15. Time is defined between 90% and 10%.
16. Load is 500 pF.
17. Time to charge C_{RES} to 11 V after application of V_{DD} .

4.3 Timing diagrams

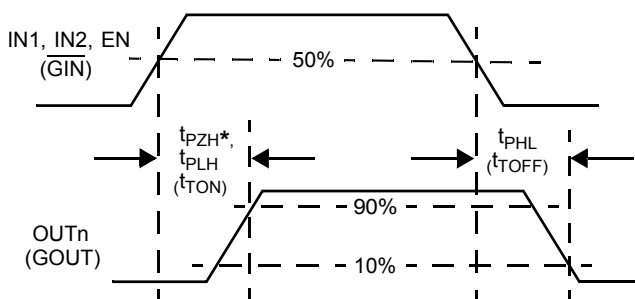

* The last state is "Z".

Figure 4. t_{PLH} , t_{PHL} , and t_{PZH} timing

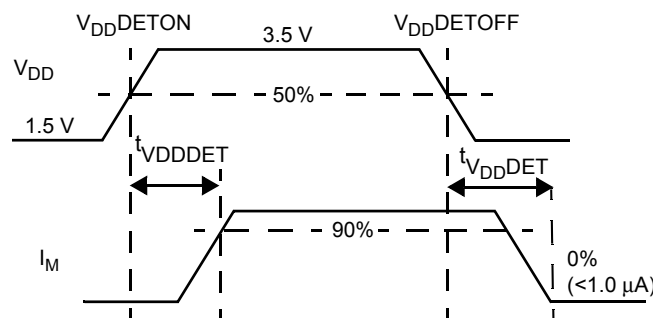

Figure 5. Low-voltage detection timing

Table 6. Truth table

INPUT				OUTPUT		
EN	IN1	IN2	GIN	OUT1	OUT2	GOUT
H	L	L	X	Z	Z	X
H	H	L	X	H	L	X
H	L	H	X	L	H	X
H	H	H	X	L	L	X
L	X	X	X	L	L	L
H	X	X	L	X	X	H
H	X	X	H	X	X	L

H = High.

L = Low.

Z = High-impedance.

X = Don't care.

The GIN pin and EN pin are pulled up to V_{DD} with internal resistance.

5 Functional description

5.1 Introduction

The 17510 is a monolithic H-Bridge power IC applicable to small DC motors used in portable electronics. The 17510 can operate efficiently with supply voltages as low as 2.0 V to as high as 15 V, and it can provide continuous motor drive currents of 1.2 A while handling peak currents up to 3.8 A. It is easily interfaced to low-cost MCUs via parallel 5.0 V-compatible logic. The device can be pulse width modulated (PWM-ed) at up to 200 kHz. The 17510 has four operating modes: Forward, Reverse, Brake, and Tri-stated (High-impedance).

Basic protection and operational features (direction, dynamic braking, PWM control of speed and torque, main power supply undervoltage detection and shutdown, logic power supply undervoltage detection and shutdown), in addition to the 1.0 A rms output current capability, make the 17510 a very attractive, cost-effective solution for controlling a broad range of small DC motors. In addition, a pair of 17510 devices can be used to control bipolar stepper motors. The 17510 can also be used to excite transformer primary windings with a switched square wave to produce secondary winding AC currents.

As shown in [Figure 2, 17510 simplified internal block diagram](#), page 3, the 17510 is a monolithic H-Bridge with built-in charge pump circuitry. For a DC motor to run, the input conditions need to be set as follows: ENable input logic HIGH, one INput logic LOW, and the other INput logic HIGH (to define output polarity). The 17510 can execute dynamic braking by setting both IN1 and IN2 logic HIGH, causing both low-side MOSFETs in the output H-Bridge to turn ON. Dynamic braking can also be implemented by taking the ENable logic LOW. The output of the H-Bridge can be set to an open-circuit high-impedance (Z) condition by taking both IN1 and IN2 logic LOW. (refer to [Table 6, Truth table](#), page 8).

The 17510 outputs are capable of providing a continuous DC load current of up to 1.2 A. An internal charge pump supports PWM frequencies to 200 kHz. The EN pin also controls the charge pump, turning it off when EN = LOW, thus allowing the 17510 to be placed in a power-conserving sleep mode.

5.2 Functional pin description

5.2.1 Output 1 and output2 (OUT1, OUT2)

The OUT1 and OUT2 pins provide the connection to the internal power MOSFET H-Bridge of the IC. A typical load connected between these pins would be a small DC motor. These outputs will connect to either VM or PGND, depending on the states of the control inputs (refer to [Table 6, Truth table](#), page 8).

5.2.2 Power ground and logic ground (PGND, LGND)

The power and logic ground pins (PGND and LGND) should be connected together with a very low-impedance connection.

5.2.3 Charge pump reservoir capacitor (CRES)

The CRES pin provides the connection for the external reservoir capacitor (output of the charge pump). Alternatively this pin can also be used as an input to supply gate-drive voltage from an external source via a series current-limiting resistor. The voltage at the CRES pin will be approximately three times the V_{DD} voltage, as the internal charge pump utilizes a voltage tripler circuit. The V_{CRES} voltage is used by the IC to supply gate drive for the internal power MOSFET H-Bridge.

5.2.4 Motor supply voltage input (VM)

The VM pins carry the main supply voltage and current into the power sections of the IC. This supply then becomes controlled and/or modulated by the IC as it delivers the power to the load attached between OUT1 and OUT2. All VM pins must be connected together on the printed circuit board with as short as possible traces offering as low impedance as possible between pins.

VM has an undervoltage threshold. If the supply voltage drops below the undervoltage threshold, the output power stage switches to a tri-state condition. When the supply voltage returns to a level that is above the threshold, the power stage automatically resumes normal operation according to the established condition of the input pins.

5.2.5 Control signal input and enable control signal input (IN1, IN2, EN)

The IN1, IN2, and EN pins are input control pins used to control the outputs. These pins are 5.0 V CMOS-compatible inputs with hysteresis. The IN1, IN2, and EN work together to control OUT1 and OUT2 (refer to [Table 6, Truth table](#)).

5.2.6 Gate driver input ($\overline{\text{GIN}}$)

The $\overline{\text{GIN}}$ input controls the GOUT pin. When $\overline{\text{GIN}}$ is set logic LOW, GOUT supplies a level-shifted high side gate drive signal to an external MOSFET. When $\overline{\text{GIN}}$ is set logic HIGH, GOUT is set to GND potential.

5.2.7 Charge pump bucket capacitor (C1L, C1H, C2L, C2H)

These two pairs of pins, the C1L and C1H and the C2L and C2H, connect to the external bucket capacitors required by the internal charge pump. The typical value for the bucket capacitors is 0.1 μF .

5.2.8 Gate driver output (GOUT)

The GOUT output pin provides a level-shifted, high side gate drive signal to an external MOSFET with C_{ISS} up to 500 pF.

5.2.9 Control circuit power supply (VDD)

The VDD pin carries the 5.0 V supply voltage and current into the logic sections of the IC. VDD has an undervoltage threshold. If the supply voltage drops below the undervoltage threshold, the output power stage switches to a tri-state condition. When the supply voltage returns to a level that is above the threshold, the power stage automatically resumes normal operation according to the established condition of the input pins.

6 Typical applications

Figure 6 shows a typical application for the 17510.

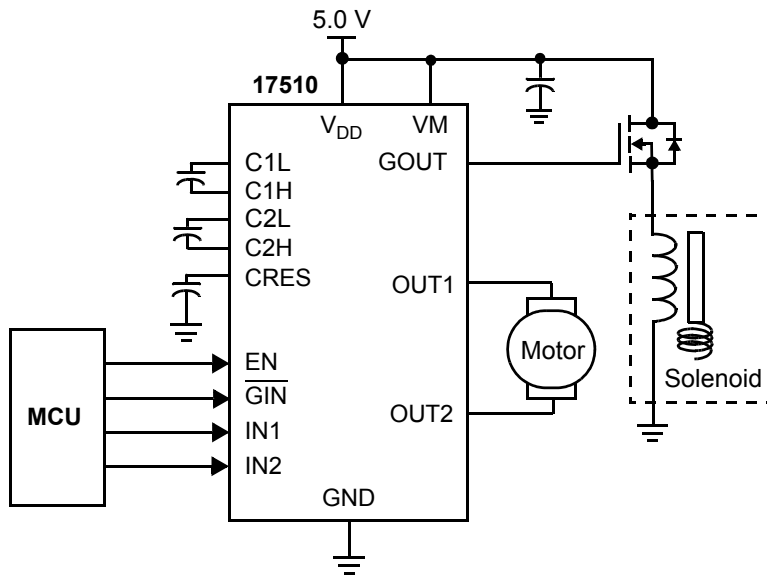

Figure 6. 17510 typical application diagram

6.1 CEMF snubbing techniques

Care must be taken to protect the IC from potentially damaging CEMF spikes induced when commutating currents in inductive loads. Typical practice is to provide snubbing of voltage transients by placing a capacitor or zener at the supply pin (VM) (see Figure 7).

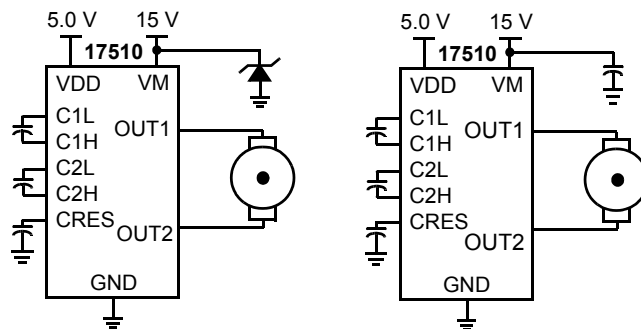
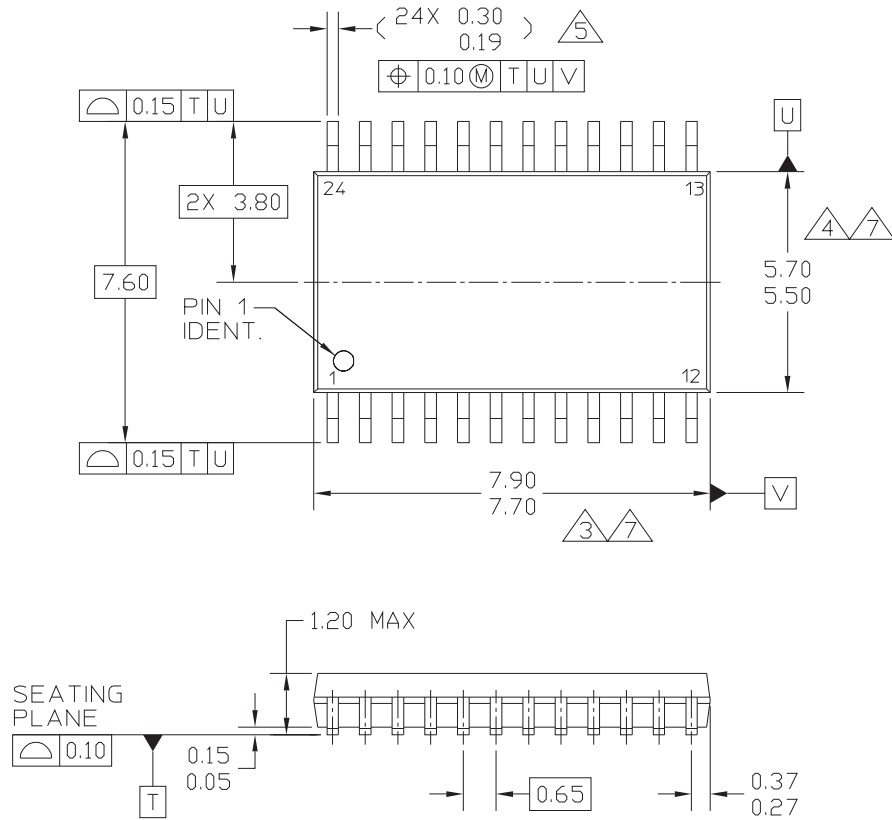

Figure 7. CEMF snubbing techniques

7 Packaging

7.1 Package dimensions

For the most current package revision, visit www.nxp.com and perform a keyword search using the “98A” listed below.



© NXP SEMICONDUCTORS N.V. ALL RIGHTS RESERVED	MECHANICAL OUTLINE	PRINT VERSION NOT TO SCALE
TITLE: 24 LD TSSOP, WIDE BODY	DOCUMENT NO: 98ASH70455A	REV: C
	STANDARD: NON-JEDEC	
	SOT1771-1	02 MAR 2016

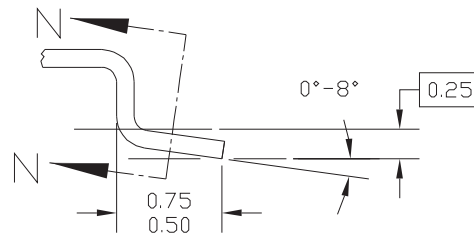
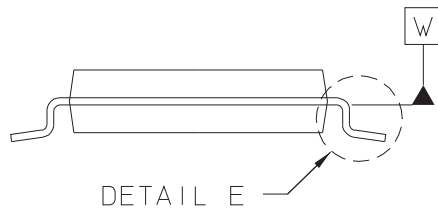

DETAIL E

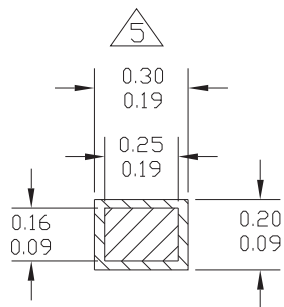

SECTION N-N

© NXP SEMICONDUCTORS N.V. ALL RIGHTS RESERVED	MECHANICAL OUTLINE	PRINT VERSION NOT TO SCALE
TITLE: 24 LD TSSOP, WIDE BODY	DOCUMENT NO: 98ASH70455A	REV: C
	STANDARD: NON-JEDEC	
	SOT1771-1	02 MAR 2016



NOTES:

1. CONTROLLING DIMENSION: MILLIMETER
2. DIMENSIONS AND TOLERANCES PER ASME Y14.5M-1994.
3. DIMENSION DOES NOT INCLUDE MOLD FLASH, PROTRUSIONS OR GATE BURRS. MOLD FLASH OR GATE BURRS SHALL NOT EXCEED 0.15 PER SIDE.
4. DIMENSION DOES NOT INCLUDE INTERLEAD FLASH OR PROTRUSION. INTERLEAD FLASH OR PROTRUSION SHALL NOT EXCEED 0.25 PER SIDE.
5. DIMENSION DOES NOT INCLUDE DAMBAR PROTRUSION. ALLOWABLE DAMBAR PROTRUSION SHALL BE 0.08 TOTAL IN EXCESS OF THE DIMENSION AT MAXIMUM MATERIAL CONDITION.
6. TERMINAL NUMBERS ARE SHOWN FOR REFERENCE ONLY.
7. DIMENSIONS ARE TO BE DETERMINED AT DATUM PLANE -W-.

© NXP SEMICONDUCTORS N.V. ALL RIGHTS RESERVED	MECHANICAL OUTLINE	PRINT VERSION NOT TO SCALE
TITLE: 24 LD TSSOP, WIDE BODY	DOCUMENT NO: 98ASH70455A	REV: C
	STANDARD: NON-JEDEC	
	SOT1771-1	02 MAR 2016

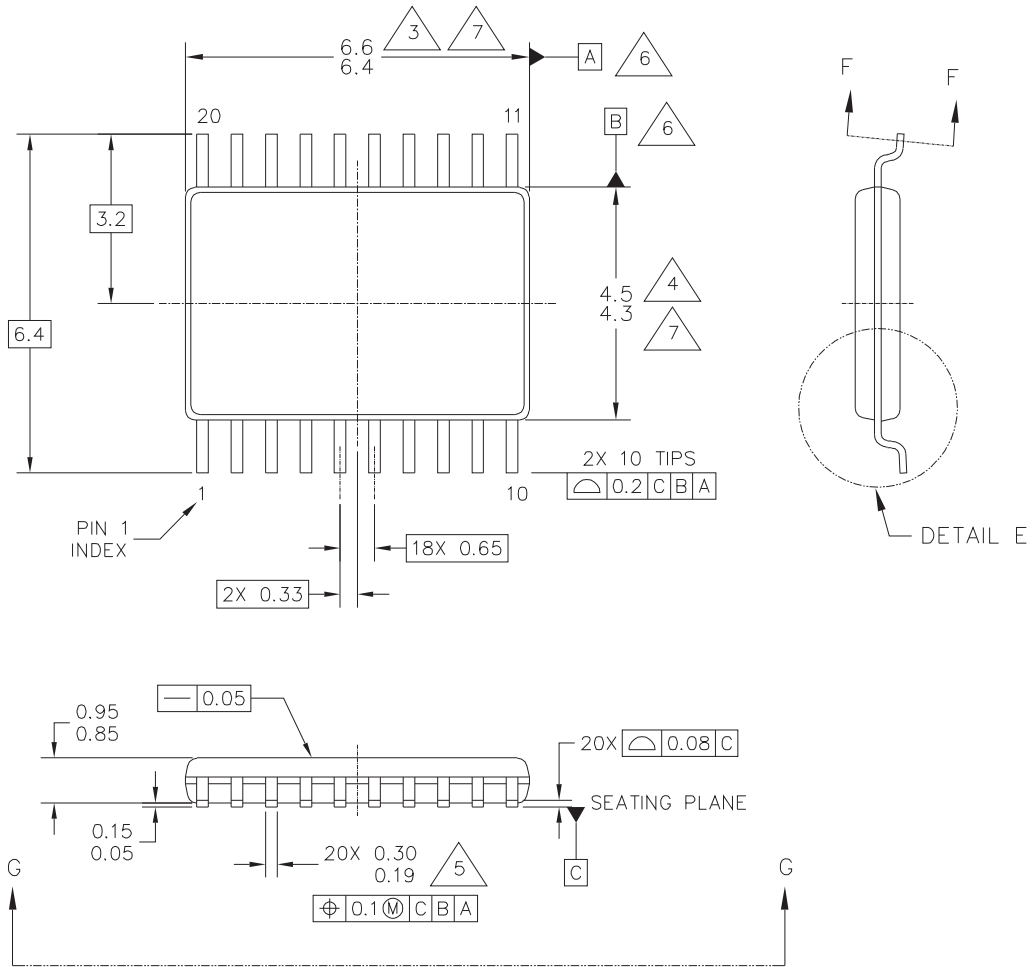

© NXP SEMICONDUCTORS N.V. ALL RIGHTS RESERVED	MECHANICAL OUTLINE	PRINT VERSION NOT TO SCALE
TITLE: TSSOP, 6.5 X 4.4 X 0.95 PKG, 0.65 PITCH, 20 TERMINAL	DOCUMENT NO: 98ASA00887D	REV: D
	STANDARD: NON-JEDEC	
	SOT527-2	24 MAR 2016

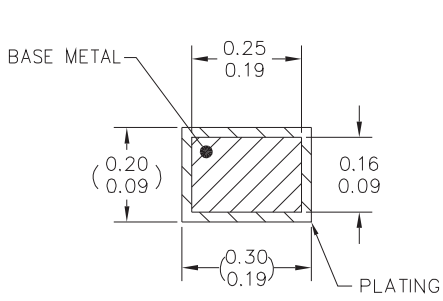

SECTION F-F

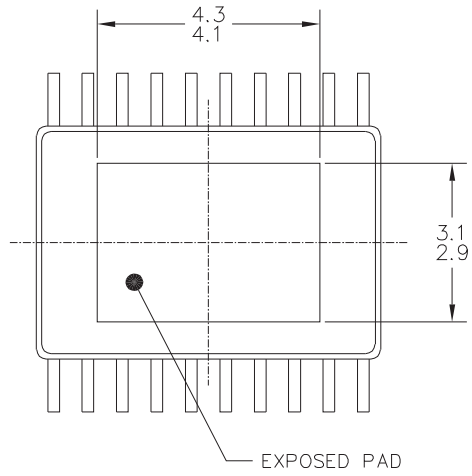

VIEW G-G

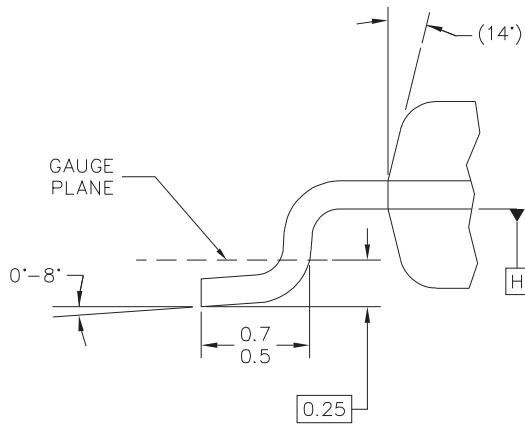

DETAIL E

© NXP SEMICONDUCTORS N.V. ALL RIGHTS RESERVED	MECHANICAL OUTLINE	PRINT VERSION NOT TO SCALE	
TITLE: TSSOP, 6.5 X 4.4 X 0.95 PKG, 0.65 PITCH, 20 TERMINAL		DOCUMENT NO: 98ASA00887D	REV: D
		STANDARD: NON-JEDEC	
		SOT527-2	24 MAR 2016

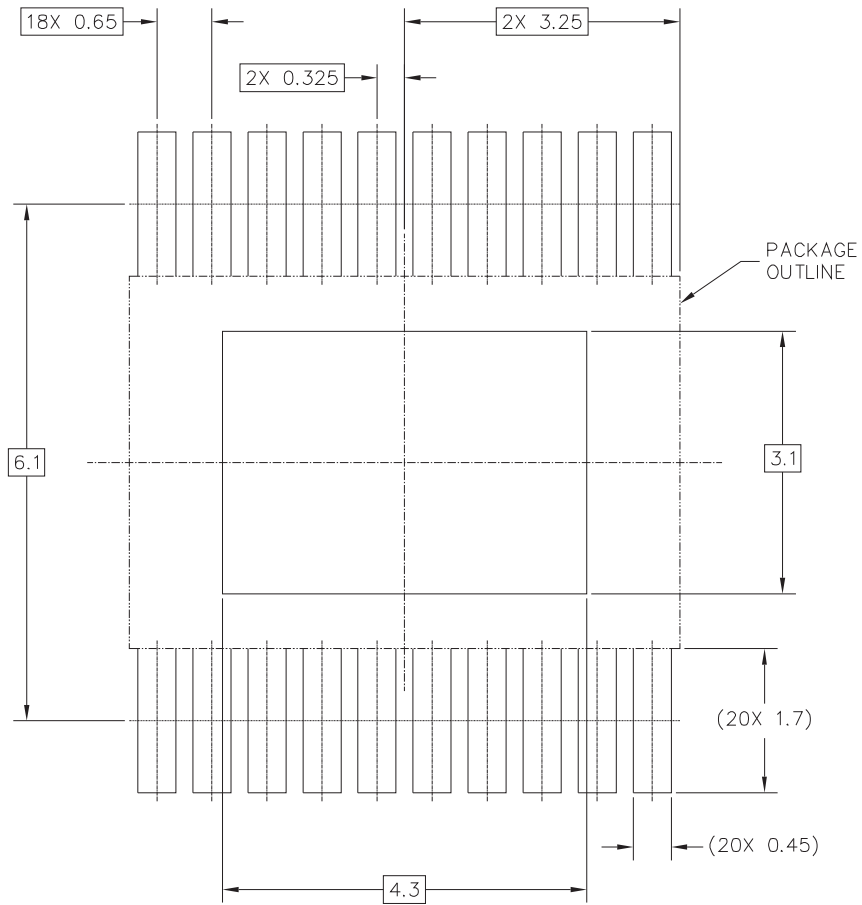

LAND PATTERN

THIS SHEET SERVES ONLY AS A GUIDELINE TO HELP DEVELOP A USER SPECIFIC SOLUTION. DEVELOPMENT EFFORT WILL STILL BE REQUIRED BY END USERS TO OPTIMIZE PCB MOUNTING PROCESSES AND BOARD DESIGN IN ORDER TO MEET INDIVIDUAL / SPECIFIC REQUIREMENTS.

© NXP SEMICONDUCTORS N.V. ALL RIGHTS RESERVED	MECHANICAL OUTLINE	PRINT VERSION NOT TO SCALE	
TITLE: TSSOP, 6.5 X 4.4 X 0.95 PKG, 0.65 PITCH, 20 TERMINAL		DOCUMENT NO: 98ASA00887D	REV: D
		STANDARD: NON-JEDEC	
		SDT527-2	24 MAR 2016



NOTES:

1. DIMENSIONS AND TOLERANCING PER ASME Y14.5M-1994.
2. DIMENSIONS ARE IN MILLIMETERS.
3. DIMENSION DOES NOT INCLUDE MOLD PROTRUSION. ALLOWABLE MOLD PROTRUSION IS 0.15 PER SIDE.
4. DIMENSION DOES NOT INCLUDE INTERLEAD FLASH OR MOLD PROTRUSION. INTERLEAD FLASH OR PROTRUSION SHALL NOT EXCEED 0.25 PER SIDE.
5. DIMENSION DOES NOT INCLUDE DAMBAR PROTRUSION. ALLOWABLE DAMBAR PROTRUSION SHALL NOT CAUSE THE LEAD WIDTH TO EXCEED THE MAXIMUM DIMENSION BY MORE THAN 0.08 MM. DAMBAR CANNOT BE LOCATED ON THE LOWER RADIUS OR THE FOOT. MINIMUM SPACE BETWEEN PROTRUSION AND ADJACENT LEAD OR PROTRUSION 0.07 MM.
6. DATUMS A AND B TO BE DETERMINED AT DATUM PLANE H.
7. DIMENSIONS TO BE DETERMINED AT SEATING PLANE C.

© NXP SEMICONDUCTORS N.V. ALL RIGHTS RESERVED	MECHANICAL OUTLINE	PRINT VERSION NOT TO SCALE
TITLE: TSSOP, 6.5 X 4.4 X 0.95 PKG, 0.65 PITCH, 20 TERMINAL	DOCUMENT NO: 98ASA00887D	REV: D
	STANDARD: NON-JEDEC	
	SOT527-2	24 MAR 2016

8 Revision history

Revision	Date	Description of changes
2.0	7/2006	<ul style="list-style-type: none">• Implemented a Revision History page.• Converted to Freescale format, and updated to the prevailing form and style• Added EJ Pb-FREE package
3.0	1/2007	<ul style="list-style-type: none">• Corrected symbol in Table 3, Driver Output ON Resistance from "W" to "Ω"
4.0	11/2013	<ul style="list-style-type: none">• Corrected pin names to match throughout the document• Corrected minor errors in format. No change in technical content• Moved data sheet to Technical Data status
5.0	7/2015	<ul style="list-style-type: none">• Added 98ASA00887D package information and updated tables where applicable• Added MPC17510AEJ to the ordering information• Updated as per PCN # 16724
	8/2015	<ul style="list-style-type: none">• Corrected the 98A package information for 20-pin TSSOP
6.0	10/2015	<ul style="list-style-type: none">• Added EP notation for TSSOP package• Fixed notations for TSSOP in Orderable parts and Pin connections• Updated Packaging 98A drawing for TSSOP• Removed MPC17510MTB parts from the data sheet. No longer manufactured.
	7/2016	<ul style="list-style-type: none">• Updated to NXP document form and style

How to Reach Us:**Home Page:**[NXP.com](http://www.nxp.com)**Web Support:**<http://www.nxp.com/support>

Information in this document is provided solely to enable system and software implementers to use NXP products. There are no expressed or implied copyright licenses granted hereunder to design or fabricate any integrated circuits based on the information in this document. NXP reserves the right to make changes without further notice to any products herein.

NXP makes no warranty, representation, or guarantee regarding the suitability of its products for any particular purpose, nor does NXP assume any liability arising out of the application or use of any product or circuit, and specifically disclaims any and all liability, including without limitation, consequential or incidental damages. "Typical" parameters that may be provided in NXP data sheets and/or specifications can and do vary in different applications, and actual performance may vary over time. All operating parameters, including "typicals," must be validated for each customer application by the customer's technical experts. NXP does not convey any license under its patent rights nor the rights of others. NXP sells products pursuant to standard terms and conditions of sale, which can be found at the following address:

<http://www.nxp.com/terms-of-use.html>.

NXP, the NXP logo, Freescale, the Freescale logo and SMARTMOS are trademarks of NXP B.V. All other product or service names are the property of their respective owners. All rights reserved.

© 2016 NXP B.V.

Document Number: MPC17510
Rev. 6.0
7/2016



X-ON Electronics

Largest Supplier of Electrical and Electronic Components

Click to view similar products for [Motor/Motion/Ignition Controllers & Drivers](#) category:

Click to view products by [Freescale](#) manufacturer:

Other Similar products are found below :

[LV8133JA-ZH](#) [LV8169MUTBG](#) [LV8774Q-AH](#) [LV8860PV-TLM-H](#) [MC33931EKR2](#) [FSB50250UTD](#) [FSB50550TB2](#) [FSBF15CH60BTH](#)
[FSBS10CH60T](#) [MP6507GR-P](#) [MP6508GF](#) [MSVCPM2-63-12](#) [MSVGW45-14-2](#) [MSVGW54-14-5](#) [NTE7043](#) [CAT3211MUTAG](#) [LA6245P-CL-TLM-E](#) [LA6245P-TLM-E](#) [LA6565VR-TLM-E](#) [LB11650-E](#) [LB1694N-E](#) [LB1837M-TLM-E](#) [LB1845DAZ-XE](#) [LC898111AXB-MH](#)
[LC898300XA-MH](#) [SS30-TE-L-E](#) [STK531-345A-E](#) [STK581U3A0D-E](#) [STK58AUNP0D-E](#) [STK621-068C-E](#) [STK621-140C](#) [STK621-728S-E](#)
[STK625-728-E](#) [STK672-400B-E](#) [STK672-432AN-E](#) [STK672-432BN-E](#) [STK672-440AN-E](#) [STK672-442AN-E](#) [AMIS30621AUA](#)
[FSB50550ASE](#) [26700](#) [LV8161MUTAG](#) [LV8281VR-TLM-H](#) [LV8702V-TLM-H](#) [LV8734VZ-TLM-H](#) [LV8773Z-E](#) [LV8807QA-MH](#)
[MC33932EK](#) [MCP8024T-H/MP](#) [TND027MP-AZ](#)