

PowerPC 603e RISC Microprocessor Family: PID7t-603e Hardware Specifications

The PowerPC™ 603e microprocessor is an implementation of the PowerPC family of reduced instruction set computing (RISC) microprocessors. In this document, the term ‘603e’ is used as an abbreviation for the PowerPC 603e microprocessor. The PowerPC 603e microprocessors are available from Freescale as MPC603e.

The 603e is implemented in several semiconductor fabrication processes. Different processes may require different supply voltages and may have other electrical differences but will have the same functionality. As a technical designator to distinguish between 603e implementations in various processes, a prefix composed of the processor version register (PVR) value and a process identifier (PID) is assigned to the various implementations as shown in [Table 1](#).

This document describes the pertinent physical characteristics of the PID7t-603e from Freescale. For functional characteristics of the 603e, refer to the *PowerPC 603e RISC Microprocessor User’s Manual*.

To locate any published errata or updates for this document, refer to the website at www.freescale.com.

Contents

1. Overview	2
2. Features	3
3. General Parameters	4
4. Electrical and Thermal Characteristics	4
5. Pin Assignments	14
6. Pinout Listings	15
7. Package Descriptions	17
8. System Design Information	20
9. Ordering Information	29
10. Revision History	30

Table 1. PowerPC 603e Microprocessors from Freescale

Technical Designator	Process	Core Voltage (V)	I/O Voltage (V)	5-Volt Tolerant	Part Number
PID6-603e	0.5 μ m CMOS, 4LM	3.3	3.3	Yes	MPC603E
PID7v-603e	0.35 μ m CMOS, 5LM	2.5	3.3	Yes	XPC603P (end-of-life)
PID7t-603e	0.29 μ m CMOS, 5LM	2.5	3.3	Yes	MPC603R

1 Overview

The 603e is a low-power implementation of the PowerPC microprocessor family of RISC microprocessors. The 603e implements the 32-bit portion of the PowerPC architecture specification that provides 32-bit effective addresses, integer data types of 8, 16, and 32 bits, and floating-point data types of 32 and 64 bits. For 64-bit PowerPC microprocessors, the PowerPC architecture provides 64-bit integer data types, 64-bit addressing, and other features required to complete the 64-bit architecture.

The 603e provides four software controllable power-saving modes. Three of the modes (the nap, doze, and sleep) are static in nature, and progressively reduce the amount of power dissipated by the processor. The fourth is a dynamic power management mode that causes the functional units in the 603e to automatically enter a low-power mode when the functional units are idle without affecting operational performance, software execution, or any external hardware.

The 603e is a superscalar processor capable of issuing and retiring as many as three instructions per clock. Instructions can execute out of order for increased performance; however, the 603e makes completion appear sequential.

The 603e integrates five execution units—an integer unit (IU), a floating-point unit (FPU), a branch processing unit (BPU), a load/store unit (LSU), and a system register unit (SRU). The ability to execute five instructions in parallel and the use of simple instructions with rapid execution times yield high efficiency and throughput for 603e-based systems. Most integer instructions execute in one clock cycle. The FPU is pipelined, so a single-precision multiply-add instruction can be issued every clock cycle.

The 603e provides independent on-chip, 16-Kbyte, four-way set-associative, physically addressed caches for instructions and data and on-chip instruction and data memory management units (MMUs). The MMUs contain 64-entry, two-way, set-associative data and instruction translation lookaside buffers (DTLB and ITLB) that provide support for demand-paged virtual memory address translation and variable-sized block translation. The TLBs and caches use a least-recently used (LRU) replacement algorithm. The 603e also supports block address translation through the use of two independent instruction and data block address translation (IBAT and DBAT) arrays of four entries each. Effective addresses are compared simultaneously with all four entries in the BAT array during block translation. In accordance with the PowerPC architecture, if an effective address hits in both the TLB and BAT array, the BAT translation takes priority.

The 603e has a selectable 32- or 64-bit data bus and a 32-bit address bus. The 603e interface protocol allows multiple masters to compete for system resources through a central external arbiter. The 603e provides a three-state coherency protocol that supports the exclusive, modified, and invalid cache states. This protocol is a compatible subset of the MESI (modified/exclusive/shared/invalid) four-state protocol

and operates coherently in systems that contain four-state caches. The 603e supports single-beat and burst data transfers for memory accesses, and supports memory-mapped I/O.

The 603e uses an advanced, 2.5/3.3-V CMOS process technology and maintains full interface compatibility with TTL devices. The PID7t-603e is offered in both PBGA and CBGA packages. The CBGA package supports speed bins of 200, 266, and 300 MHz. The PBGA package is a pin-compatible drop in replacement for the CBGA; however, this package only supports speeds up to 200 MHz.

2 Features

This section summarizes features of the 603e's implementation of the PowerPC architecture. Major features of the 603e are as follows:

- High-performance, superscalar microprocessor
 - As many as three instructions issued and retired per clock
 - As many as five instructions in execution per clock
 - Single-cycle execution for most instructions
 - Pipelined FPU for all single-precision and most double-precision operations
- Five independent execution units and two register files
 - BPU featuring static branch prediction
 - A 32-bit IU
 - Fully IEEE 754-compliant FPU for both single- and double-precision operations
 - LSU for data transfer between data cache and GPRs and FPRs
 - SRU that executes condition register (CR), special-purpose register (SPR) instructions, and integer add/compare instructions
 - 32 GPRs for integer operands
 - 32 FPRs for single- or double-precision operands
- High instruction and data throughput
 - Zero-cycle branch capability (branch folding)
 - Programmable static branch prediction on unresolved conditional branches
 - Instruction fetch unit capable of fetching two instructions per clock from the instruction cache
 - A six-entry instruction queue that provides lookahead capability
 - Independent pipelines with feed-forwarding that reduces data dependencies in hardware
 - 16-Kbyte data cache—four-way, set-associative physically addressed; LRU replacement algorithm
 - 16-Kbyte instruction cache—four-way, set-associative physically addressed; LRU replacement algorithm
 - Cache write-back or write-through operation programmable on a per page or per block basis
 - BPU that performs CR lookahead operations
 - Address translation facilities for 4-Kbyte page size, variable block size, and 256-Mbyte segment size

- A 64-entry two-way, set-associative ITLB
- A 64-entry two-way, set-associative DTLB
- Four-entry data and instruction BAT arrays providing 128-Kbyte to 256-Mbyte blocks
- Software table search operations and updates supported through fast trap mechanism
- 52-bit virtual and 32-bit physical address
- Facilities for enhanced system performance
 - A 32- or 64-bit split-transaction external data bus with burst transfers
 - Support for one-level address pipelining and out-of-order bus transactions
- Integrated power management
 - Low-power 2.5/3.3-volt design
 - Internal processor/bus clock multiplier that provides 2:1, 2.5:1, 3:1, 3.5:1, 4:1, 4.5:1, 5:1, 5.5:1, and 6:1 ratios
 - Three power-saving modes: doze, nap, and sleep
 - Automatic dynamic power reduction when internal functional units are idle
- In-system testability and debugging features through JTAG boundary-scan capability

3 General Parameters

The following list provides a summary of the general parameters of the PID7t-603e:

Technology	0.29 μ m CMOS, five-layer metal
Die size	5.65 mm x 7.7 mm (44 mm ²)
Transistor count	2.6 million
Logic design	Fully-static
Package	255 ceramic ball grid array (CBGA) or 225 thin map plastic ball grid array (PBGA)
Core power supply	2.5 \pm 5% V dc
I/O power supply	3.3 \pm 5% V dc

4 Electrical and Thermal Characteristics

This section provides the AC and DC electrical specifications and thermal characteristics for the PID7t-603e.

4.1 DC Electrical Characteristics

The tables in this section describe the PID7t-603e DC electrical characteristics. This table provides the absolute maximum ratings.

Table 2. Absolute Maximum Ratings

Characteristic	Symbol	Value	Unit
Core supply voltage	V_{dd}	-0.3 to 2.75	V
PLL supply voltage	AV_{dd}	-0.3 to 2.75	V
I/O supply voltage	OV_{dd}	-0.3 to 3.6	V
Input voltage	V_{in}	-0.3 to 5.5	V
Storage temperature range	T_{stg}	-55 to 150	°C

Note:

- Functional and tested operating conditions are given in [Table 3](#). Absolute maximum ratings are stress ratings only, and functional operation at the maximums is not guaranteed. Stresses beyond those listed may affect device reliability or cause permanent damage to the device.
- Caution:** V_{in} must not exceed OV_{dd} by more than 2.5 V at any time, including during power-on reset.
- Caution:** OV_{dd} must not exceed V_{dd}/AV_{dd} by more than 1.2 V at any time, including during power-on reset.
- Caution:** V_{dd}/AV_{dd} must not exceed OV_{dd} by more than 0.4 V at any time, including during power-on reset.

This table provides the recommended operating conditions for the PID7t-603e.

Table 3. Recommended Operating Conditions

Characteristic	Symbol	Value	Unit
Core supply voltage	V_{dd}	2.375 to 2.625	V
PLL supply voltage	AV_{dd}	2.375 to 2.625	V
I/O supply voltage	OV_{dd}	3.135 to 3.465	V
Input voltage	V_{in}	GND to 5.5	V
Die-junction temperature	T_j	0 to 105	°C

Note: These are the recommended and tested operating conditions. Proper device operation outside of these conditions is not guaranteed.

This table provides the package thermal characteristics for the PID7t-603e.

Table 4. Package Thermal Characteristics

Characteristic	Symbol	Value CBGA	Value PBGA	Rating
Package die junction-to-case thermal resistance (typical)	θ_{JC}	0.095	8.0	°C/W
Package die junction-to-ball thermal resistance (typical)	θ_{JB}	3.5	13	°C/W

Note: For more about thermal management, see [Section 8, "System Design Information."](#)

Electrical and Thermal Characteristics

This table provides the DC electrical characteristics for the PID7t-603e.

Table 5. DC Electrical Specifications

$V_{dd} = AV_{dd} = 2.5 \pm 5\% V$ dc, $OV_{dd} = 3.3 \pm 5\% V$ dc, $GND = 0 V$ dc, $0 \leq T_j \leq 105^\circ C$

Characteristic	Symbol	Min	Max	Unit	Note
Input high voltage (all inputs except SYSCLK)	V_{IH}	2.0	5.5	V	—
Input low voltage (all inputs except SYSCLK)	V_{IL}	GND	0.8	V	—
SYSCLK input high voltage	CV_{IH}	2.4	5.5	V	—
SYSCLK input low voltage	CV_{IL}	GND	0.4	V	—
Input leakage current, $V_{in} = 3.465 V$	I_{in}	—	30	μA	1, 2
$V_{in} = 5.5 V$	I_{in}	—	300	μA	1, 2
Hi-Z (off-state) leakage current, $V_{in} = 3.465 V$	I_{TSI}	—	30	μA	1, 2
$V_{in} = 5.5 V$	I_{TSI}	—	300	μA	1, 2
Output high voltage, $I_{OH} = -7 mA$	V_{OH}	2.4	—	V	—
Output low voltage, $I_{OL} = 7 mA$	V_{OL}	—	0.4	V	—
Capacitance, $V_{in} = 0 V$, $f = 1 MHz$ (excludes \overline{TS} , \overline{ABB} , \overline{DBB} , and \overline{ARTRY})	C_{in}	—	10.0	pF	3
Capacitance, $V_{in} = 0 V$, $f = 1 MHz$ (for \overline{TS} , \overline{ABB} , \overline{DBB} , and \overline{ARTRY})	C_{in}	—	15.0	pF	3

Notes:

- Excludes test signals (LSSD_MODE, L1_TSTCLK, L2_TSTCLK, and JTAG signals).
- The leakage is measured for nominal OV_{dd} and V_{dd} or both OV_{dd} and V_{dd} must vary in the same direction (for example, both OV_{dd} and V_{dd} vary by either +5% or -5%).
- Capacitance is periodically sampled rather than 100% tested.

This table provides the power consumption for the PID7t-603e.

Table 6. Power Consumption

	Processor (CPU) Frequency							Unit
	100 MHz	133 MHz	166 MHz	200 MHz	233 MHz	266 MHz	300 MHz	
Full-On Mode (DPM Enabled)								
Typical	1.1	1.6	2.1	2.5	3.0	3.5	4.0	W
Maximum	1.6	2.4	3.2	4.0	4.6	5.3	6.0	W
Doze Mode								
Typical	0.55	0.7	0.9	1.1	1.3	1.5	1.8	W
Nap Mode								
Typical	50	60	75	85	100	120	130	mW
Sleep Mode								
Typical	45	50	55	65	75	90	100	mW
Sleep Mode—PLL Disabled								

Table 6. Power Consumption (continued)

	Processor (CPU) Frequency							Unit
	100 MHz	133 MHz	166 MHz	200 MHz	233 MHz	266 MHz	300 MHz	
Typical	40	40	40	40	40	40	40	mW
Sleep Mode—PLL and SYSCLK Disabled								
Typical	15	15	15	15	15	15	15	mW
Maximum	25	25	25	25	25	80	100	mW

Note:

1. These values apply for all valid PLL_CFG[0–3] settings and do not include output driver power (OV_{dd}) or analog supply power (AV_{dd}). OV_{dd} power is system dependent but is typically $\leq 10\%$ of V_{dd} . Worst-case $AV_{dd} = 15$ mW.
2. Typical power is an average value measured at $V_{dd} = AV_{dd} = 2.5$ V, $OV_{dd} = 3.3$ V, in a system executing typical applications and benchmark sequences.
3. Maximum power is measured at 2.625 V using a worst-case instruction mix.

4.2 AC Electrical Characteristics

This section provides the AC electrical characteristics for the PID7t-603e. These specifications are for 200, 266, and 300 MHz processor speed grades. The processor core frequency is determined by the bus (SYSCLK) frequency and the settings of the PLL_CFG[0–3] signals. All timings are specified relative to the rising edge of SYSCLK. PLL_CFG signals should be set prior to power up and not altered afterwards.

4.2.1 Clock AC Specifications

This table provides the clock AC timing specifications as defined in Figure 1. After fabrication, parts are sorted by maximum processor core frequency as shown in Section 4.2.1, “Clock AC Specifications,” and tested for conformance to the AC specifications for that frequency. Parts are sold by maximum processor core frequency; see Section 9, “Ordering Information.”

Table 7. Clock AC Timing Specifications

$V_{dd} = AV_{dd} = 2.5 \pm 5\%$ V dc, $OV_{dd} = 3.3 \pm 5\%$ V dc, GND = 0 V dc, $0 \leq T_j \leq 105$ °C

Num	Characteristic	200 MHz PBGA		200 MHz CBGA		266 MHz CBGA		300 MHz CBGA		Unit	Note
		Min	Max	Min	Max	Min	Max	Min	Max		
	Processor frequency	100	200	80	200	150	266	180	300	MHz	1, 6
	VCO frequency	300	400	300	400	300	532	360	600	MHz	1
	SYSCLK frequency	25	66.67	25	66.67	25	75	33.3	75	MHz	1
1	SYSCLK cycle time	13.3	40	13.3	40	13.3	40	13.3	30	ns	
2, 3	SYSCLK rise and fall time	—	2.0	—	2.0	—	2.0	—	2.0	ns	2
4	SYSCLK duty cycle measured at 1.4 V	40.0	60.0	40.0	60.0	40.0	60.0	40.0	60.0	%	3

Table 7. Clock AC Timing Specifications (continued)

$V_{dd} = AV_{dd} = 2.5 \pm 5\% \text{ V dc}$, $OV_{dd} = 3.3 \pm 5\% \text{ V dc}$, $GND = 0 \text{ V dc}$, $0 \leq T_j \leq 105 \text{ }^\circ\text{C}$

Num	Characteristic	200 MHz PBGA		200 MHz CBGA		266 MHz CBGA		300 MHz CBGA		Unit	Note
		Min	Max	Min	Max	Min	Max	Min	Max		
	SYSCLK jitter	—	±150	—	±150	—	±150	—	±150	ps	4
	PID7t internal PLL-relock time	—	100	—	100	—	100	—	100	µs	3, 5

Note:

- Caution:** The SYSCLK frequency and PLL_CFG[0–3] settings must be chosen such that the resulting SYSCLK (bus) frequency, CPU (core) frequency, and PLL (VCO) frequency do not exceed their respective maximum or minimum operating frequencies. Refer to the PLL_CFG[0–3] signal description in [Section 8, “System Design Information,”](#) for valid PLL_CFG[0–3] settings.
- Rise and fall times for the SYSCLK input are measured from 0.4 V to 2.4 V.
- Timing is guaranteed by design and characterization, and is not tested.
- Cycle-to-cycle jitter, and is guaranteed by design. The total input jitter (short term and long term combined) must be under ±150 ps to guarantee the input/output timing of [Section 4.2.2, “Input AC Specifications,”](#) and [Section 4.2.3, “Output AC Specifications.”](#)
- Relock timing is guaranteed by design and characterization, and is not tested. PLL-relock time is the maximum time required for PLL lock after a stable V_{dd} , OV_{dd} , AV_{dd} , and SYSCLK are reached during the power-on reset sequence. This specification also applies when the PLL has been disabled and subsequently re-enabled during sleep mode. Also note that HRESET must be held asserted for a minimum of 255 bus clocks after the PLL-relock time (100 µs) during the power-on reset sequence.
- Operation below 150 MHz is supported only by PLL_CFG[0–3] = 0b0101. Refer to [Section 8.1, “PLL Configuration”](#) for additional information.

This figure provides the SYSCLK input timing diagram.

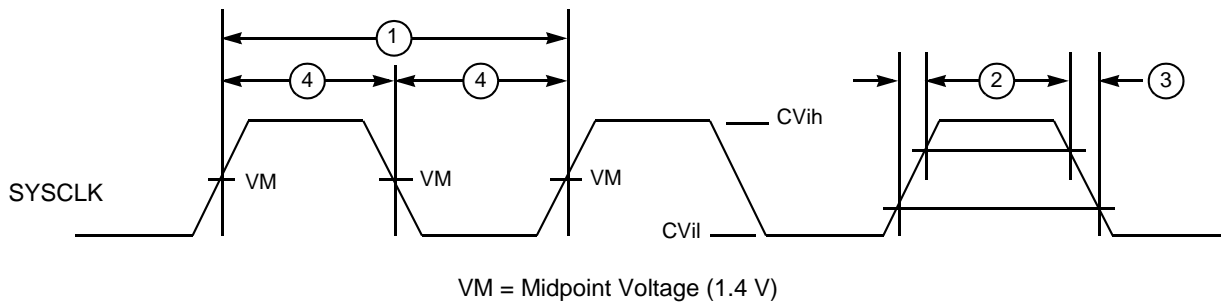

Figure 1. SYSCLK Input Timing Diagram

4.2.2 Input AC Specifications

This table provides the input AC timing specifications for the PID7t-603e as defined in [Figure 2](#) and [Figure 3](#).

Table 8. Input AC Timing Specifications¹
 $V_{dd} = AV_{dd} = 2.5 \pm 5\% \text{ V dc}$, $OV_{dd} = 3.3 \pm 5\% \text{ V dc}$, $GND = 0 \text{ V dc}$, $0 \leq T_j \leq 105^\circ \text{ C}$

Num	Characteristic	200, 266, 300 MHz		Unit	Notes
		Min	Max		
10a	Address/data/transfer attribute inputs valid to SYSCLK (input setup)	2.5	—	ns	2
10b	All other inputs valid to SYSCLK (input setup)	3.5	—	ns	3
10c	Mode select inputs valid to $\overline{\text{HRESET}}$ (input setup) (for $\overline{\text{DRTRY}}$, $\overline{\text{QACK}}$ and $\overline{\text{TLBISYNC}}$)	8	—	t_{sysclk}	4, 5, 6, 7
11a	SYSCLK to address/data/transfer attribute inputs invalid (input hold)	1.0	—	ns	2
11b	SYSCLK to all other inputs invalid (input hold)	1.0	—	ns	3
11c	$\overline{\text{HRESET}}$ to mode select inputs invalid (input hold) (for $\overline{\text{DRTRY}}$, $\overline{\text{QACK}}$, and $\overline{\text{TLBISYNC}}$)	0	—	ns	4, 6, 7

Note:

- Input specifications are measured from the TTL level (0.8 or 2.0 V) of the signal in question to the 1.4 V of the rising edge of the input SYSCLK. Input and output timings are measured at the pin.
- Address/data/transfer attribute input signals are composed of the following— $A[0-31]$, $AP[0-3]$, $TT[0-4]$, $TC[0-1]$, $\overline{\text{TBST}}$, $\text{TSIZ}[0-2]$, $\overline{\text{GBL}}$, $\text{DH}[0-31]$, $\text{DL}[0-31]$, $\text{DP}[0-7]$.
- All other input signals are composed of the following— $\overline{\text{TS}}$, $\overline{\text{ABB}}$, $\overline{\text{DBB}}$, $\overline{\text{ARTRY}}$, $\overline{\text{BG}}$, $\overline{\text{AACK}}$, $\overline{\text{DBG}}$, $\overline{\text{DBWO}}$, $\overline{\text{TA}}$, $\overline{\text{DRTRY}}$, $\overline{\text{TEA}}$, $\overline{\text{DBDIS}}$, $\overline{\text{HRESET}}$, $\overline{\text{SRESET}}$, $\overline{\text{INT}}$, $\overline{\text{SMI}}$, $\overline{\text{MCP}}$, $\overline{\text{TBEN}}$, $\overline{\text{QACK}}$, $\overline{\text{TLBISYNC}}$.
- The setup and hold time is with respect to the rising edge of $\overline{\text{HRESET}}$ (see Figure 3).
- t_{sysclk} is the period of the external clock (SYSCLK) in nanoseconds (ns). The numbers given in the table must be multiplied by the period of SYSCLK to compute the actual time duration (in nanoseconds) of the parameter in question.
- These values are guaranteed by design, and are not tested.
- This specification is for configuration mode only. Also note that $\overline{\text{HRESET}}$ must be held asserted for a minimum of 255 bus clocks after the PLL-relock time during the power-on reset sequence.

This figure provides the input timing diagram for the PID7t-603e.

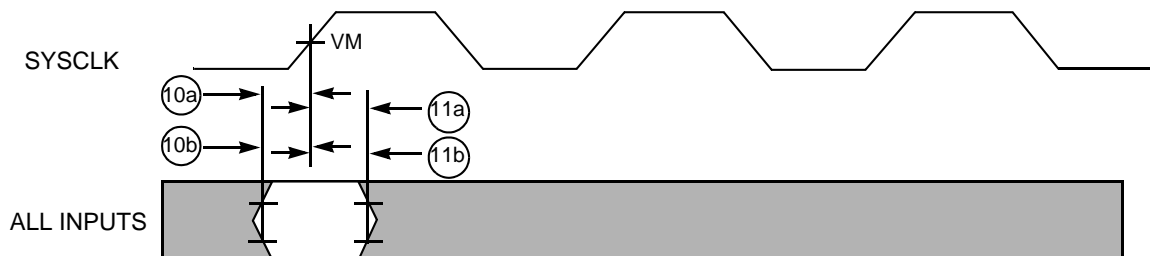

VM = Midpoint Voltage (1.4 V)

Figure 2. Input Timing Diagram

This figure provides the mode select input timing diagram for the PID7t-603e.

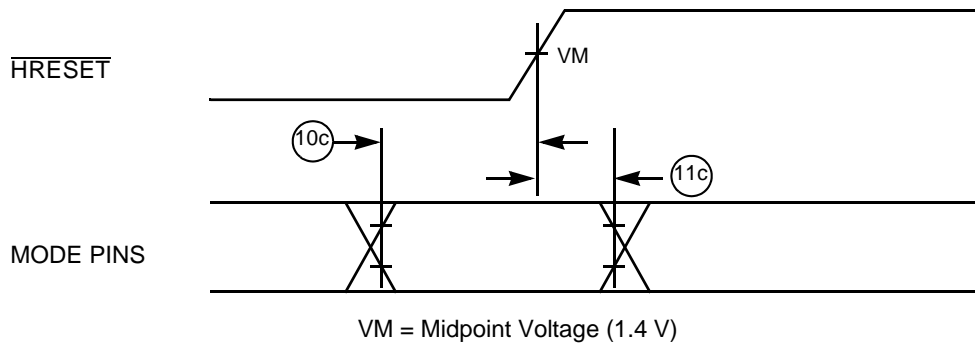

Figure 3. Mode Select Input Timing Diagram

4.2.3 Output AC Specifications

This table provides the output AC timing specifications for the PID7t-603e as defined in Figure 4.

Table 9. Output AC Timing Specifications¹

$V_{dd} = AV_{dd} = 2.5 \pm 5\% V$ dc, $OV_{dd} = 3.3 \pm 5\%$, $GND = 0 V$ dc, $0 \leq T_j \leq 105^\circ C$, $C_L = 50 pF$ (unless otherwise noted)

Num	Characteristic	200, 266, 300 MHz		Unit	Note
		Min	Max		
12	SYSCLK to output driven (output enable time)	1.0	—	ns	—
13a	SYSCLK to output valid (5.5 V to 0.8 V— \overline{TS} , \overline{ABB} , \overline{ARTRY} , \overline{DBB})	—	9.0	ns	3
13b	SYSCLK to output valid (\overline{TS} , \overline{ABB} , \overline{ARTRY} , \overline{DBB})	—	8.0	ns	5
14a	SYSCLK to output valid (5.5 V to 0.8 V—all except \overline{TS} , \overline{ABB} , \overline{ARTRY} , \overline{DBB})	—	11.0	ns	3
14b	SYSCLK to output valid (all except \overline{TS} , \overline{ABB} , \overline{ARTRY} , \overline{DBB})	—	9.0	ns	5
15	SYSCLK to output invalid (output hold)	1.0	—	ns	2
16	SYSCLK to output high impedance (all except \overline{ARTRY} , \overline{ABB} , \overline{DBB})	—	8.0	ns	—
17	SYSCLK to \overline{ABB} , \overline{DBB} , high impedance after precharge	—	1.0	t_{sysclk}	4, 6
18	SYSCLK to \overline{ARTRY} high impedance before precharge	—	7.5	ns	—
19	SYSCLK to \overline{ARTRY} precharge enable	$0.2 * t_{sysclk} + 1.0$	—	ns	2, 4, 7
20	Maximum delay to \overline{ARTRY} precharge	—	1.0	t_{sysclk}	4, 7
21	SYSCLK to \overline{ARTRY} high impedance after precharge	—	2.0	t_{sysclk}	5, 7

Table 9. Output AC Timing Specifications¹ (continued)

$V_{dd} = AV_{dd} = 2.5 \pm 5\% \text{ V dc}$, $OV_{dd} = 3.3 \pm 5\%$, $GND = 0 \text{ V dc}$, $0 \leq T_j \leq 105 \text{ }^\circ\text{C}$, $C_L = 50 \text{ pF}$ (unless otherwise noted)

Num	Characteristic	200, 266, 300 MHz		Unit	Note
		Min	Max		

Note:

1. All output specifications are measured from the 1.4 V of the rising edge of SYSCLK to the TTL level (0.8 V or 2.0 V) of the signal in question. Both input and output timings are measured at the pin (see Figure 4).
2. This minimum parameter assumes $C_L = 0 \text{ pF}$.
3. SYSCLK to output valid (5.5 V to 0.8 V) includes the extra delay associated with discharging the external voltage from 5.5 V to 0.8 V instead of from V_{dd} to 0.8 V (5-V CMOS levels instead of 3.3-V CMOS levels).
4. t_{sysclk} is the period of the external bus clock (SYSCLK) in nanoseconds (ns). The numbers given in the table must be multiplied by the period of SYSCLK to compute the actual time duration (in nanoseconds) of the parameter in question.
5. Output signal transitions from \overline{GND} to 2.0 V or V_{dd} to 0.8 V.
6. Nominal precharge width for \overline{ABB} and \overline{DBB} is $0.5 t_{\text{sysclk}}$.
7. Nominal precharge width for \overline{ARTRY} is $1.0 t_{\text{sysclk}}$.

This figure provides the output timing diagram for the PID7t-603e.

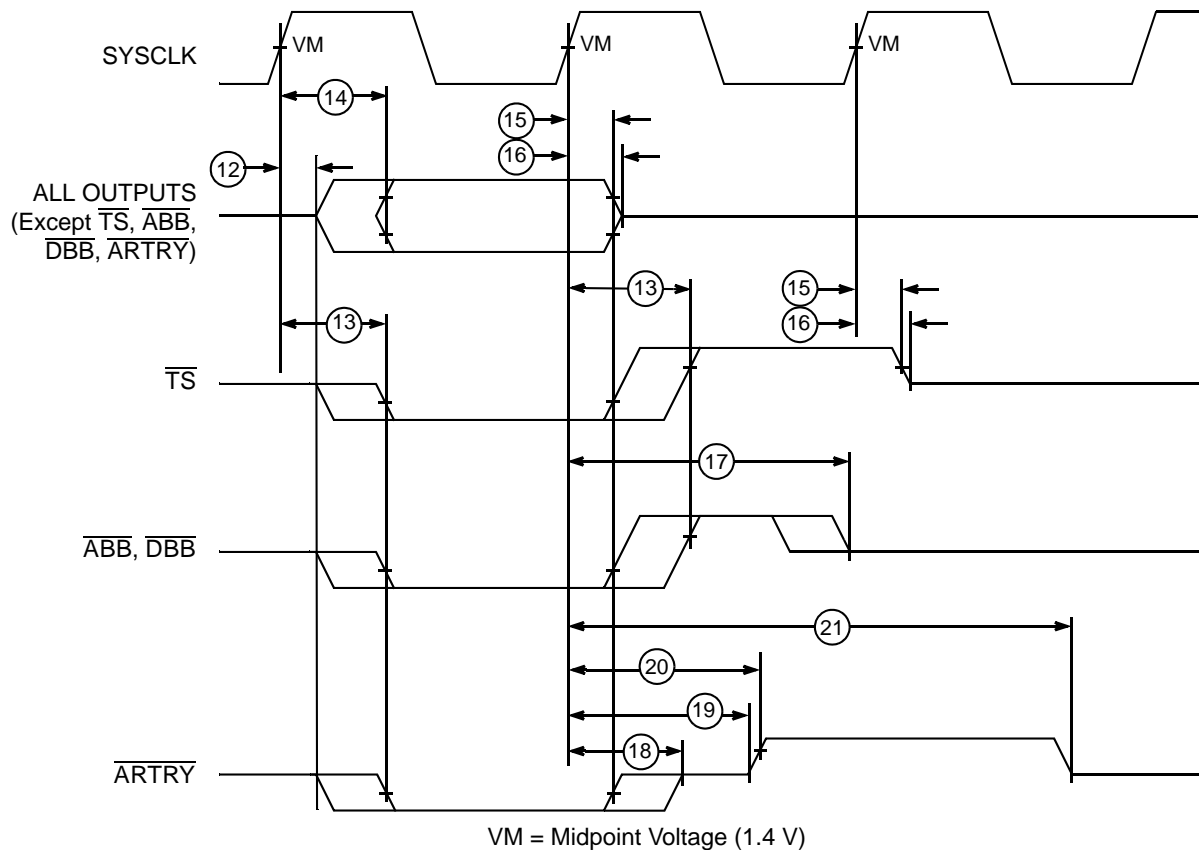

Figure 4. Output Timing Diagram

4.3 JTAG AC Timing Specifications

This table provides the JTAG AC timing specifications as defined in Figure 5–Figure 8.

Table 10. JTAG AC Timing Specifications

$V_{dd} = AV_{dd} = 2.5 \pm 5\% \text{ V dc}$, $OV_{dd} = 3.3 \pm 5\%$, $GND = 0 \text{ V dc}$, $0 \leq T_j \leq 105^\circ \text{ C}$, $C_L = 50 \text{ pF}$

Num	Characteristic	Min	Max	Unit	Note
	TCK frequency of operation	0	16	MHz	—
1	TCK cycle time	62.5	—	ns	—
2	TCK clock pulse width measured at 1.4 V	25	—	ns	—
3	TCK rise and fall times	0	3	ns	—
4	$\overline{\text{TRST}}$ setup time to TCK rising edge	13	—	ns	1
5	$\overline{\text{TRST}}$ assert time	40	—	ns	—
6	Boundary scan input data setup time	6	—	ns	2
7	Boundary scan input data hold time	27	—	ns	2
8	TCK to output data valid	4	25	ns	3
9	TCK to output high impedance	3	24	ns	3
10	TMS, TDI data setup time	0	—	ns	—
11	TMS, TDI data hold time	25	—	ns	—
12	TCK to TDO data valid	4	24	ns	—
13	TCK to TDO high impedance	3	15	ns	—

Note:

1. $\overline{\text{TRST}}$ is an asynchronous signal. The setup time is for test purposes only.
2. Non-test signal input timing with respect to TCK.
3. Non-test signal output timing with respect to TCK.

This figure provides the JTAG clock input timing diagram.

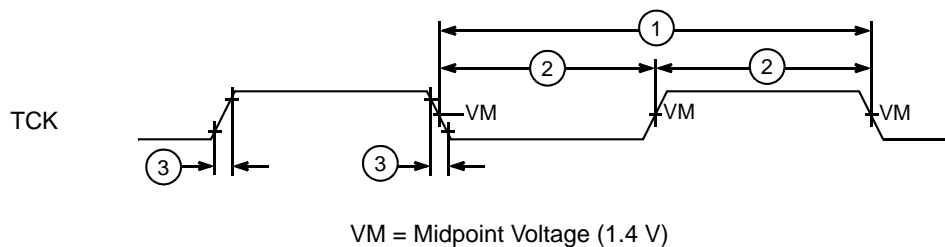

Figure 5. JTAG Clock Input Timing Diagram

This figure provides the $\overline{\text{TRST}}$ timing diagram.

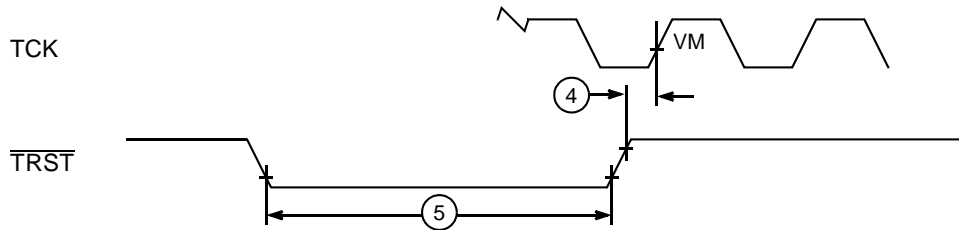

Figure 6. $\overline{\text{TRST}}$ Timing Diagram

This figure provides the boundary-scan timing diagram.

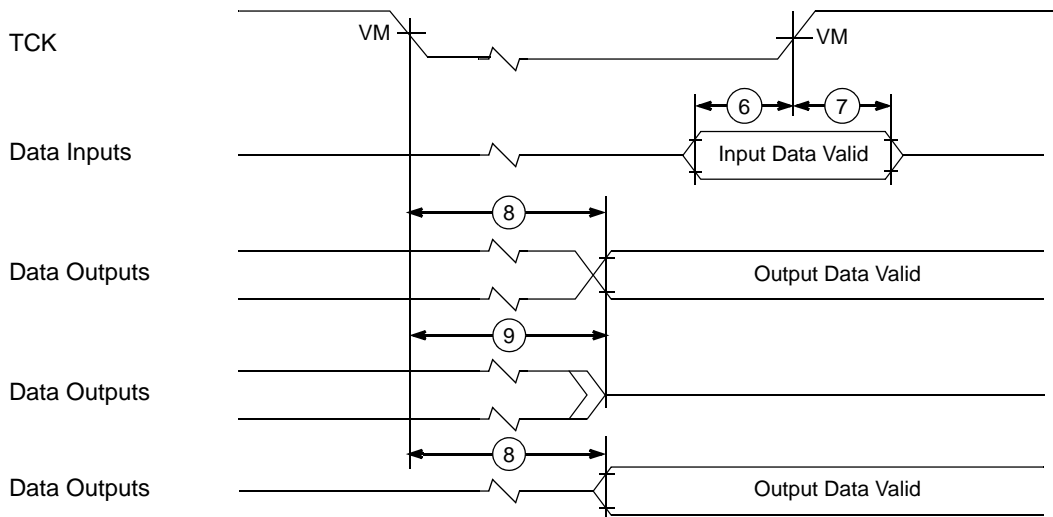

Figure 7. Boundary-Scan Timing Diagram

This figure provides the test access port timing diagram.

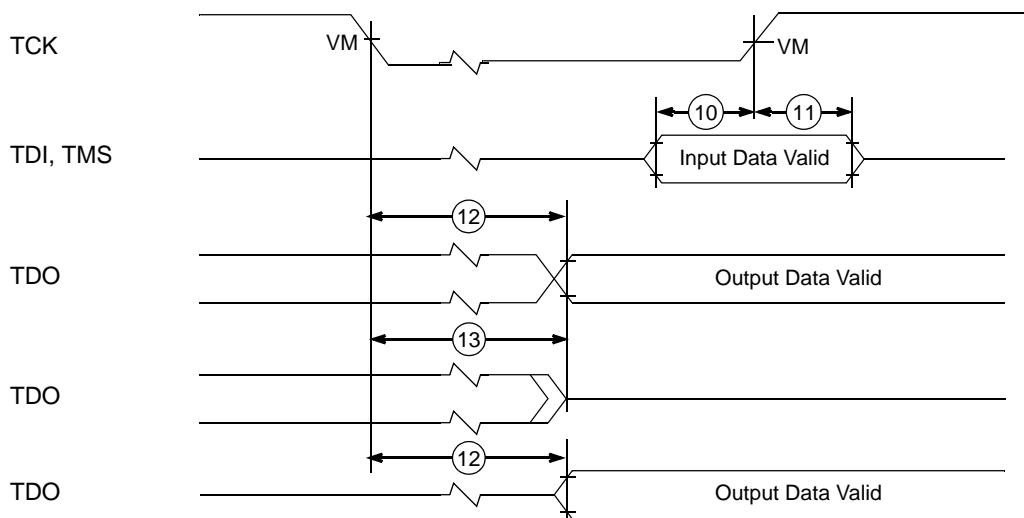
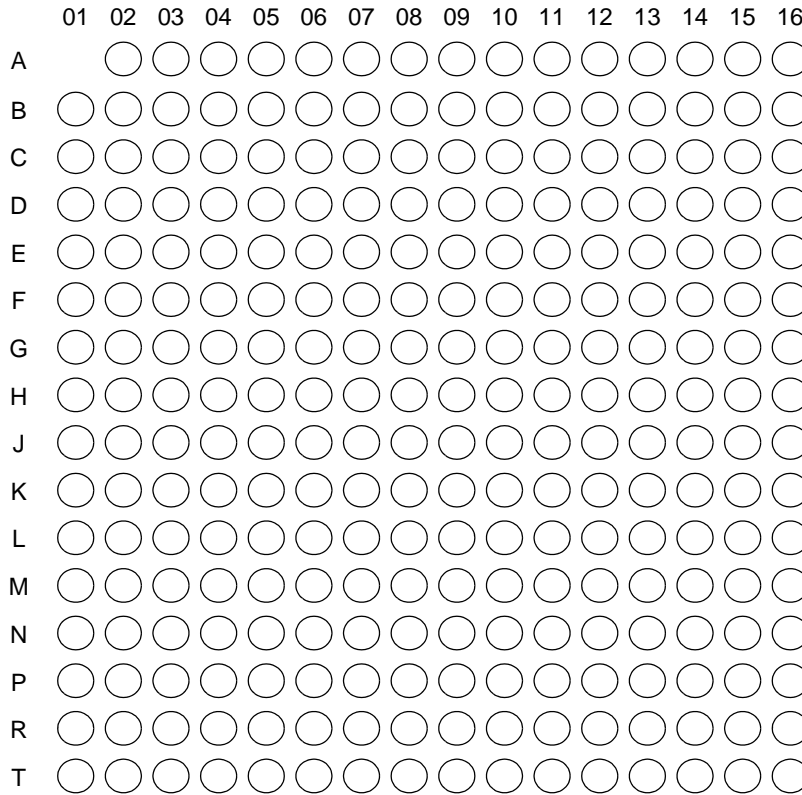

Figure 8. Test Access Port Timing Diagram

5 Pin Assignments

Part A of [Figure 9](#) shows the pinout of the CBGA package as viewed from the top surface. Part B shows the side profile of the CBGA package to indicate the direction of the top surface view. The PBGA package has an identical pinout. Part C shows the side profile of the PBGA package to indicate the direction of the top surface view.

Part A



Not to Scale

Part B

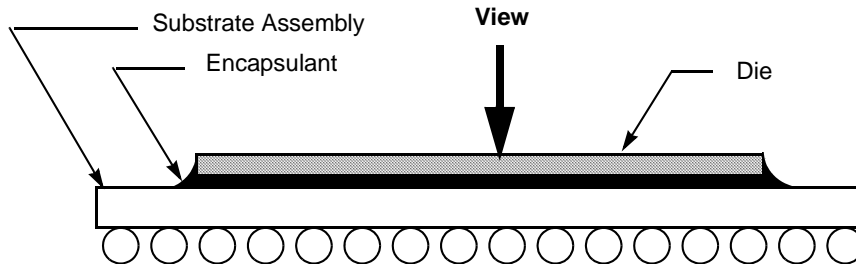

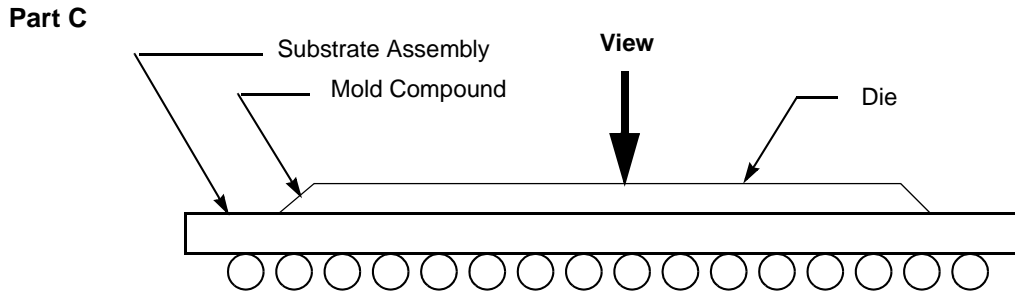

Figure 9. Pinout of the CBGA and PBGA Packages as Viewed from the Top Surface

6 Pinout Listings

This table provides the pinout listing for the 603e CBGA and PBGA packages.

Table 11. Pinout Listing for the 255-Pin CBGA and PBGA Packages

Signal Name	Pin Number	Active	I/O
A[0–31]	C16, E04, D13, F02, D14, G01, D15, E02, D16, D04, E13, G02, E15, H01, E16, H02, F13, J01, F14, J02, F15, H03, F16, F04, G13, K01, G15, K02, H16, M01, J15, P01	High	I/O
AACK	L02	Low	I
ABB	K04	Low	I/O
AP[0–3]	C01, B04, B03, B02	High	I/O
APE	A04	Low	O
ARTRY	J04	Low	I/O
AV _{DD}	A10	—	—
BG	L01	Low	I
BR	B06	Low	O
CI	E01	Low	O
CKSTP_IN	D08	Low	I
CKSTP_OUT	A06	Low	O
CLK_OUT	D07	—	O
CSE[0–1]	B01, B05	High	O
DBB	J14	Low	I/O
DBG	N01	Low	I
DBDIS	H15	Low	I
DBWO	G04	Low	I
DH[0–31]	P14, T16, R15, T15, R13, R12, P11, N11, R11, T12, T11, R10, P09, N09, T10, R09, T09, P08, N08, R08, T08, N07, R07, T07, P06, N06, R06, T06, R05, N05, T05, T04	High	I/O
DL[0–31]	K13, K15, K16, L16, L15, L13, L14, M16, M15, M13, N16, N15, N13, N14, P16, P15, R16, R14, T14, N10, P13, N12, T13, P03, N03, N04, R03, T01, T02, P04, T03, R04	High	I/O

Table 11. Pinout Listing for the 255-Pin CBGA and PBGA Packages (continued)

Signal Name	Pin Number	Active	I/O
DP[0–7]	M02, L03, N02, L04, R01, P02, M04, R02	High	I/O
DPE	A05	Low	O
DRTRY	G16	Low	I
GBL	F01	Low	I/O
GND	C05, C12, E03, E06, E08, E09, E11, E14, F05, F07, F10, F12, G06, G08, G09, G11, H05, H07, H10, H12, J05, J07, J10, J12, K06, K08, K09, K11, L05, L07, L10, L12, M03, M06, M08, M09, M11, M14, P05, P12	—	—
HRESET	A07	Low	I
INT	B15	Low	I
L1_TSTCLK ¹	D11	—	I
L2_TSTCLK ¹	D12	—	I
LSSD_MODE ¹	B10	Low	I
MCP	C13	Low	I
NC (No-Connect)	B07, B08, C03, C06, C08, D05, D06, H04, J16	—	—
OV _{DD}	C07, E05, E07, E10, E12, G03, G05, G12, G14, K03, K05, K12, K14, M05, M07, M10, M12, P07, P10	—	—
PLL_CFG[0–3]	A08, B09, A09, D09	High	I
QACK	D03	Low	I
QREQ	J03	Low	O
RSRV	D01	Low	O
SMI	A16	Low	I
SRESET	B14	Low	I
SYSCLK	C09	—	I
TA	H14	Low	I
TBEN	C02	High	I
TBST	A14	Low	I/O
TC[0–1]	A02, A03	High	O
TCK	C11	—	I
TDI	A11	High	I
TDO	A12	High	O
TEA	H13	Low	I
TLBISYNC	C04	Low	I
TMS	B11	High	I
TRST	C10	Low	I

Table 11. Pinout Listing for the 255-Pin CBGA and PBGA Packages (continued)

Signal Name	Pin Number	Active	I/O
TS	J13	Low	I/O
TSIZ[0–2]	A13, D10, B12	High	O
TT[0–4]	B13, A15, B16, C14, C15	High	I/O
WT	D02	Low	O
V_{DD}^2	F06, F08, F09, F11, G07, G10, H06, H08, H09, H11, J06, J08, J09, J11, K07, K10, L06, L08, L09, L11	—	—
VOLTDGND ³	F03	Low	O

Note:

1. These are test signals for factory use only and must be pulled up to OV_{dd} for normal machine operation.
2. OV_{dd} inputs supply power to the I/O drivers and V_{dd} inputs supply power to the processor core.
3. NC (no-connect) in the PID6-603e; internally tied to GND in the PID7v-603e and PID7t-603e CBGA and PBGA package to indicate to the power supply that a low-voltage processor is present.

7 Package Descriptions

The following sections provide the CBGA and PBGA package parameters and the mechanical dimensions for the 603e.

7.1 CBGA Package Description

The following sections provide the package parameters and mechanical dimensions for the CBGA package.

7.1.1 Package Parameters

The package parameters are as provided in the following list. The package type is 21 mm x 21 mm, 255-lead ceramic ball grid array (CBGA).

Package outline	21 mm x 21 mm
Interconnects	255
Pitch	1.27 mm (50 mil)
Package height	Minimum: 2.45 mm Maximum: 3.00 mm
Ball diameter	0.89 mm (35 mil)
Maximum heat sink force	10 lbs

7.1.2 Mechanical Dimensions of the CBGA Package

This figure provides the mechanical dimensions and bottom surface nomenclature of the CBGA package.

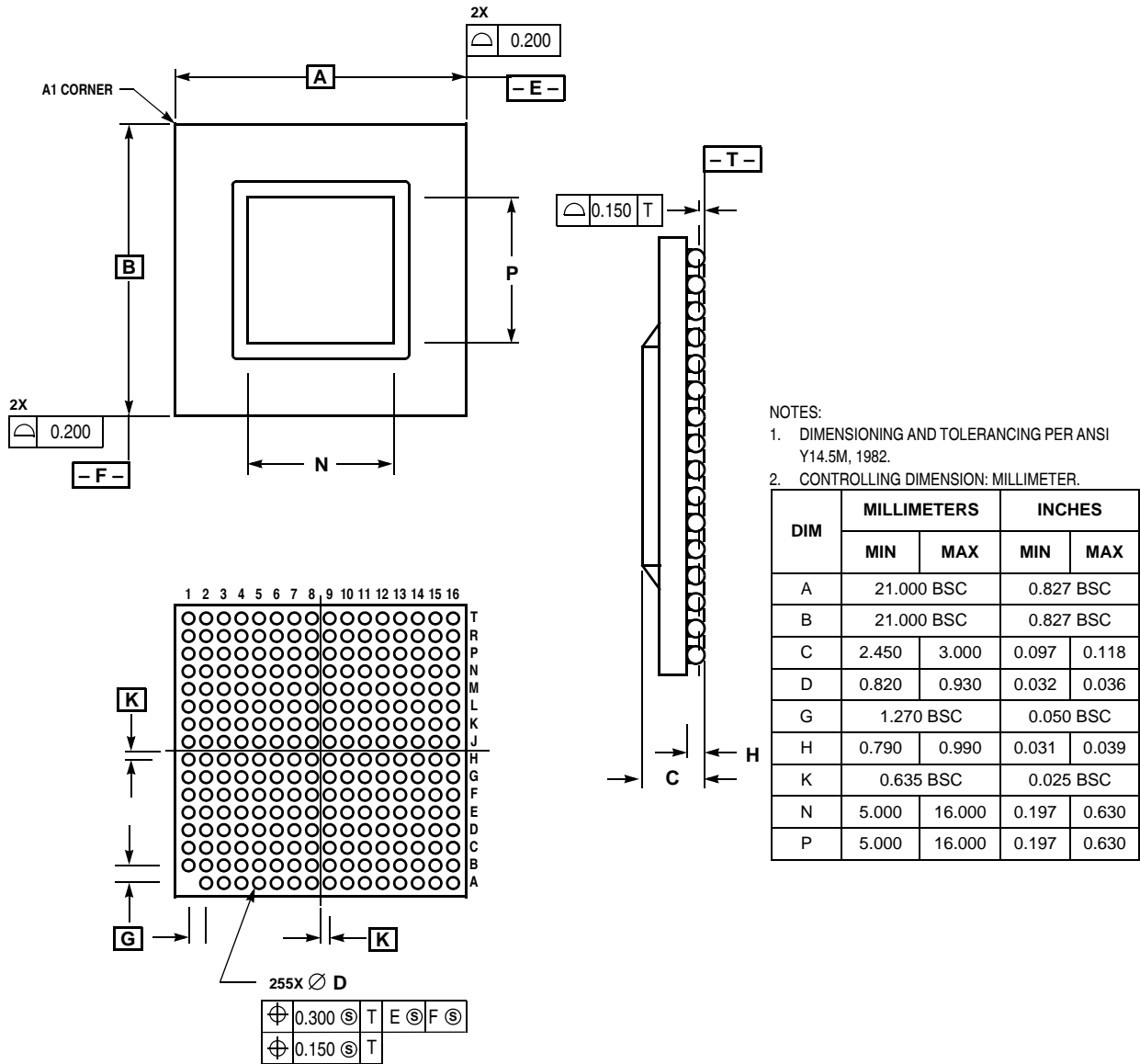

Figure 10. Mechanical Dimensions and Bottom Surface Nomenclature of the CBGA Package

7.2 PBGA Package Description

The following sections provide the package parameters and mechanical dimensions.

7.2.1 Package Parameters

The package type is 23 mm x 23 mm, 255-lead plastic ball grid array (PBGA).

Package outline 23 mm x 23 mm

Interconnects	255
Pitch	1.27 mm (50 mil)
Package height	Minimum: 2.1 mm; Maximum: 2.6 mm
Ball diameter	0.76 mm (30 mil)
Maximum heat sink force	5 lbs

7.2.2 Mechanical Dimensions of the PBGA Package

This figure shows the non-JEDEC package mechanical dimensions and bottom surface nomenclature.

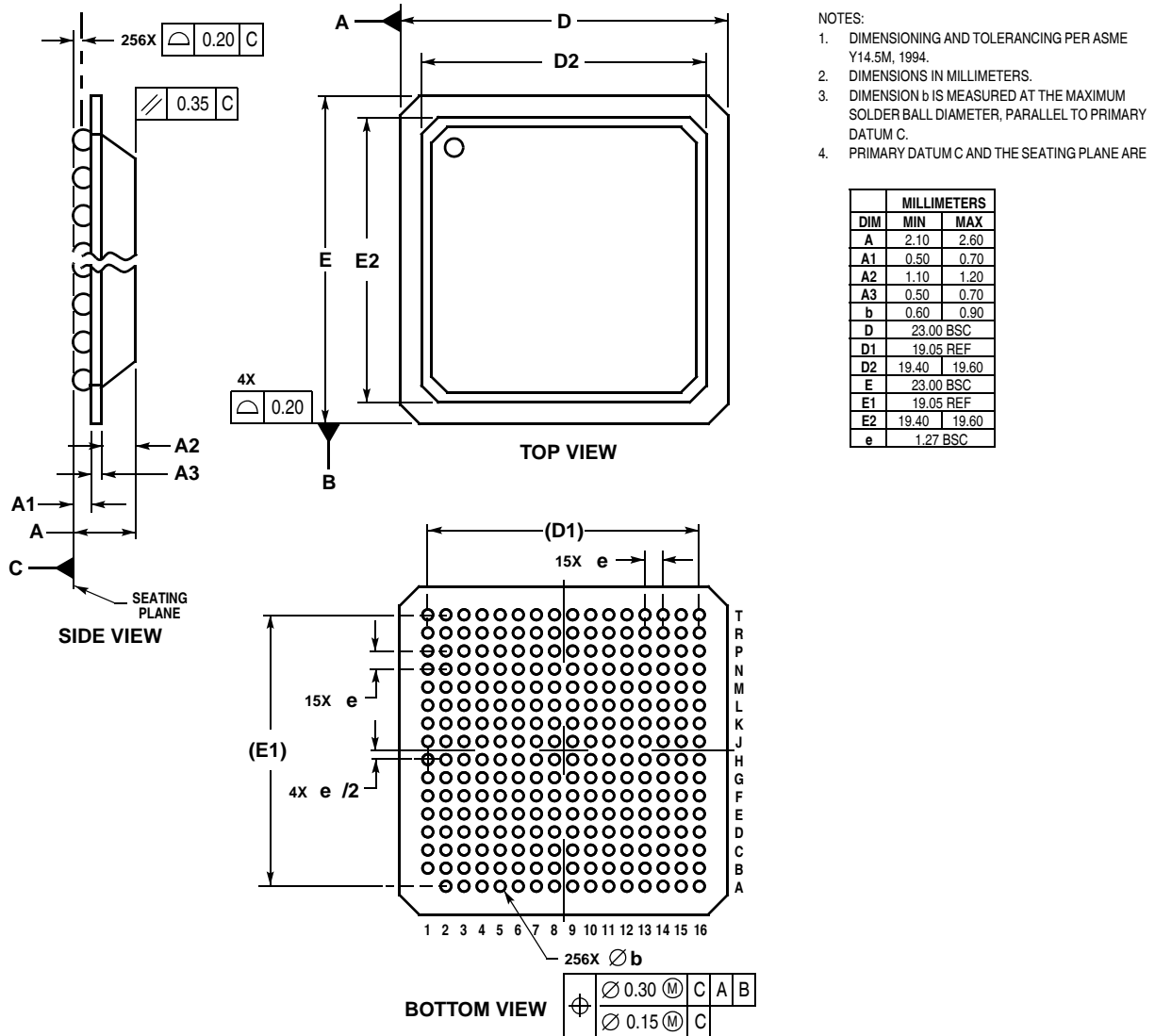
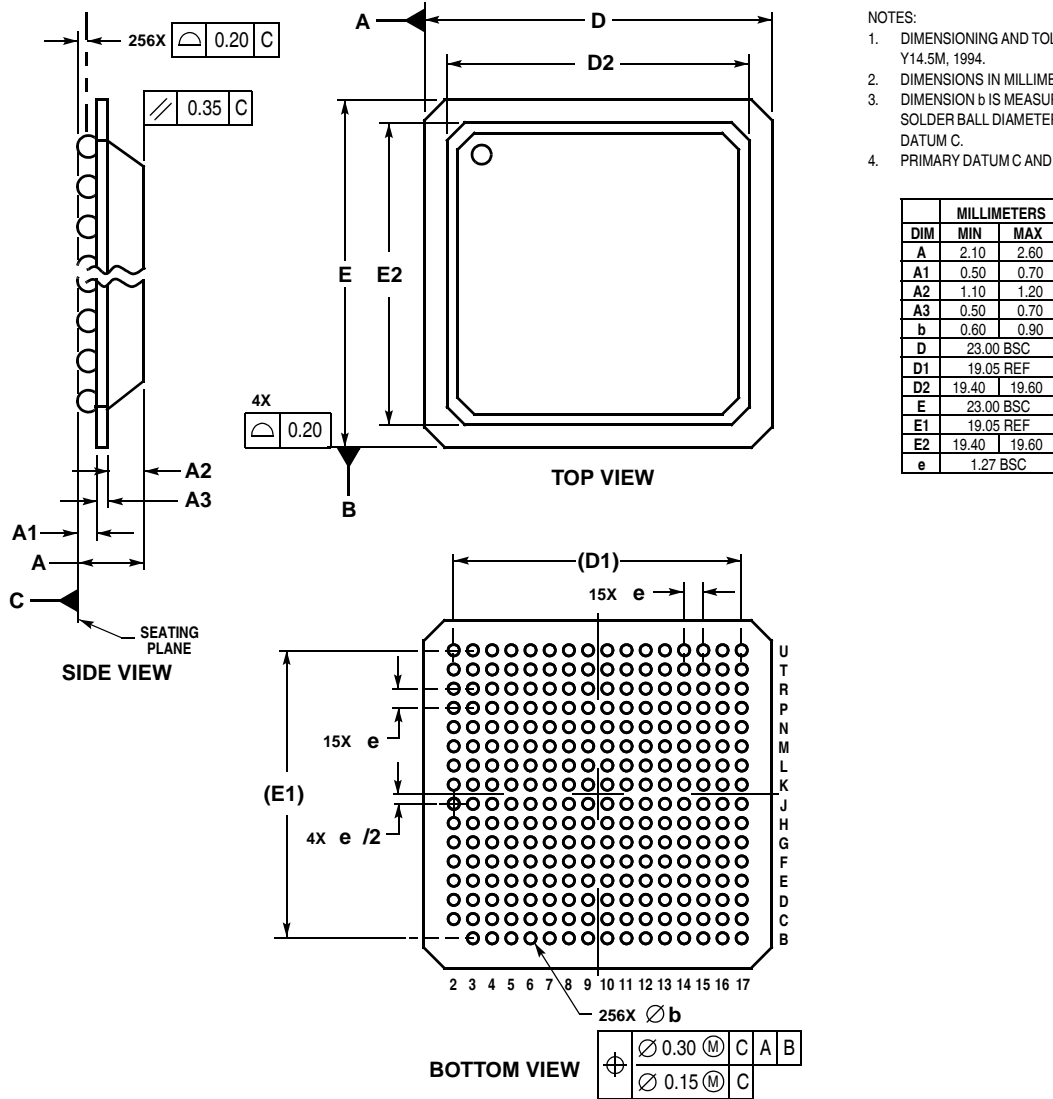

Figure 11. Package Dimensions for the Plastic Ball Grid Array (PBGA)—non-JEDEC Standard

Note that Table 11 lists the pinout to this non-JEDEC standard in order to be consistent with the CBGA pinout. This figure shows the JEDEC package dimensions of the PBGA package.



CASE 1167-01

Figure 12. Package Dimensions for the Plastic Ball Grid Array (PBGA)—JEDEC Standard

Note that the pin numberings shown in Figure 12 do not match Table 11; the pinout of the non-JEDEC standard package (and the CBGA pinout) is shown in Figure 11. Note that Figure 11 should be used in conjunction with Table 11 for the complete pinout description.

8 System Design Information

This section provides electrical and thermal design recommendations for successful application of 603e.

8.1 PLL Configuration

The 603e PLL is configured by the PLL_CFG[0–3] signals. For a given SYSCLK (bus) frequency, the PLL configuration signals set the internal CPU and VCO frequency of operation. The PLL configuration for the PID7t-603e is shown in this table for nominal frequencies.

Table 12. PLL Configuration

PLL_CFG[0:3]	CPU Frequency in MHz (VCO Frequency in MHz)								
	Bus-to-Core Multiplier	Core-to-VCO Multiplier	Bus 25 MHz	Bus 33.33 MHz	Bus 40 MHz	Bus 50 MHz	Bus 60 MHz	Bus 66.67 MHz	Bus 75 MHz
0100	2x	2x	—	—	—	—	—	—	150 (300)
0101	2x	4x	—	—	80 ⁴ (320)	100 (400)	120 (480)	133 (532)	150 (600)
0110	2.5x	2x	—	—	—	—	150 (300)	166 (333)	187 (375)
1000	3x	2x	—	—	—	150 (300)	180 (360)	200 (400)	225 (450)
1110	3.5x	2x	—	—	—	175 (350)	210 (420)	233 (466)	263 (525)
1010	4x	2x	—	—	160 (320)	200 (400)	240 (480)	267 (533)	300 (600)
0111	4.5x	2x	—	150 (300)	180 (360)	225 (450)	270 (540)	300 (600)	—
1011	5x	2x	—	166 (333)	200 (400)	250 (500)	300 (600)	—	—
1001	5.5x	2x	—	183 (366)	220 (440)	275 (550)	—	—	—
1101	6x	2x	150 (300)	200 (400)	240 (480)	300 (600)	—	—	—
0011	PLL bypass								
1111	Clock off								

Note:

- Some PLL configurations may select bus, CPU, or VCO frequencies which are not supported; see [Section 4.2.1, “Clock AC Specifications,”](#) for valid SYSCLK and VCO frequencies.
- In PLL-bypass mode, the SYSCLK input signal clocks the internal processor directly, the PLL is disabled, and the bus mode is set for 1:1 mode operation. This mode is intended for factory use only.
Note: The AC timing specifications given in this document do not apply in PLL-bypass mode.
- In clock-off mode, no clocking occurs inside the 603e regardless of the SYSCLK input.
- 80 MHz operation is not supported for the PBGA package (see [Table 7](#)).

8.2 PLL Power Supply Filtering

The AV_{dd} power signal is provided on the 603e to provide power to the clock generation phase-locked loop. To ensure stability of the internal clock, the power supplied to the AV_{dd} input signal should be filtered

using a circuit similar to the one shown in Figure 13. The circuit should be placed as close as possible to the AV_{dd} pin to ensure it filters out as much noise as possible. The 0.1 μF capacitor should be closest to the AV_{dd} pin, followed by the 10 μF capacitor, and finally the 10 Ω resistor to V_{dd}. These traces should be kept short and direct.

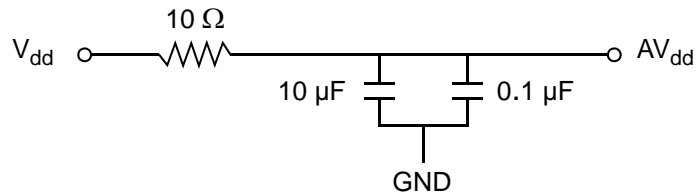

Figure 13. PLL Power Supply Filter Circuit

8.3 Decoupling Recommendations

Due to the 603e's dynamic power management feature, large address, data buses, and high-operating frequencies, it can generate transient power surges and high-frequency noise in its power supply, especially while driving large capacitive loads. This noise must be prevented from reaching other components in the 603e system. It requires a clean, tightly regulated source of power. Therefore, it is recommended that the system designer places at least one decoupling capacitor at each V_{dd} and OV_{dd} pin of the 603e. It is also recommended that these decoupling capacitors receive their power from separate V_{dd}, OV_{dd}, and GND power planes in the PCB, utilizing short traces to minimize inductance.

These capacitors should vary in value from 220 pF to 10 μF to provide both high- and low-frequency filtering, and should be placed as close as possible to their associated V_{dd} or OV_{dd} pin. Suggested values for the V_{dd} pins are: 220 pF (ceramic), 0.01 μF (ceramic), and 0.1 μF (ceramic). Suggested values for the OV_{dd} pins are: 0.01 μF (ceramic), 0.1 μF (ceramic), and 10 μF (tantalum). Only SMT capacitors should be used to minimize lead inductance.

In addition, it is recommended that there be several bulk storage capacitors distributed around the PCB, feeding the V_{dd} and OV_{dd} planes, to enable quick recharging of the smaller chip capacitors. These bulk capacitors should also have a low ESR (equivalent series resistance) rating to ensure the quick response time necessary. They should also be connected to the power and ground planes through two vias to minimize inductance. Suggested bulk capacitors—100 μF (AVX TPS tantalum) or 330 μF (AVX TPS tantalum).

8.4 Connection Recommendations

To ensure reliable operation, it is highly recommended to connect unused inputs to an appropriate signal level. Unused active low inputs should be tied to V_{dd}. Unused active high inputs should be connected to GND. All NC (no-connect) signals must remain unconnected. Power and ground connections must be made to all external V_{dd}, OV_{dd}, and GND pins of the 603e.

8.5 Pull-up Resistor Requirements

The 603e requires high-resistive (weak: 10 K Ω) pull-up resistors on several control signals of the bus interface to maintain the control signals in the negated state after they have been actively negated and released by the 603e or other bus master. These signals are: \overline{TS} , \overline{ABB} , \overline{DBB} , and \overline{ARTRY} .

In addition, the 603e has three open-drain style outputs that require pull-up resistors (weak or stronger: 4.7 K Ω –10 K Ω) if they are used by the system. These signals are: \overline{APE} , \overline{DPE} , and $\overline{CKSTP_OUT}$.

During inactive periods on the bus, the address and transfer attributes on the bus are not driven by any master and may float in the high-impedance state for relatively long periods of time. Since the 603e must continually monitor these signals for snooping, this float condition may cause excessive power draw by the input receivers on the 603e. It is recommended that these signals be pulled up through weak (10 K Ω) pull-up resistors or restored in some manner by the system. The snooped address and transfer attribute inputs are—A[0–31], AP[0–3], TT[0–4], \overline{TBST} , and \overline{GBL} .

The data bus input receivers are normally turned off when no read operation is in progress and do not require pull-up resistors on the data bus.

8.6 Thermal Management Information

This section provides thermal management information for the CBGA and PBGA packages for air-cooled applications. Proper thermal control design is primarily dependent upon the system-level design—the heat sink, airflow and thermal interface material.

This figure shows the upper and lower limits of the die junction-to-ambient thermal resistance for both package styles. The lower limit is shown for the case of a densely populated PCB with high thermal loading of adjacent and neighboring components.

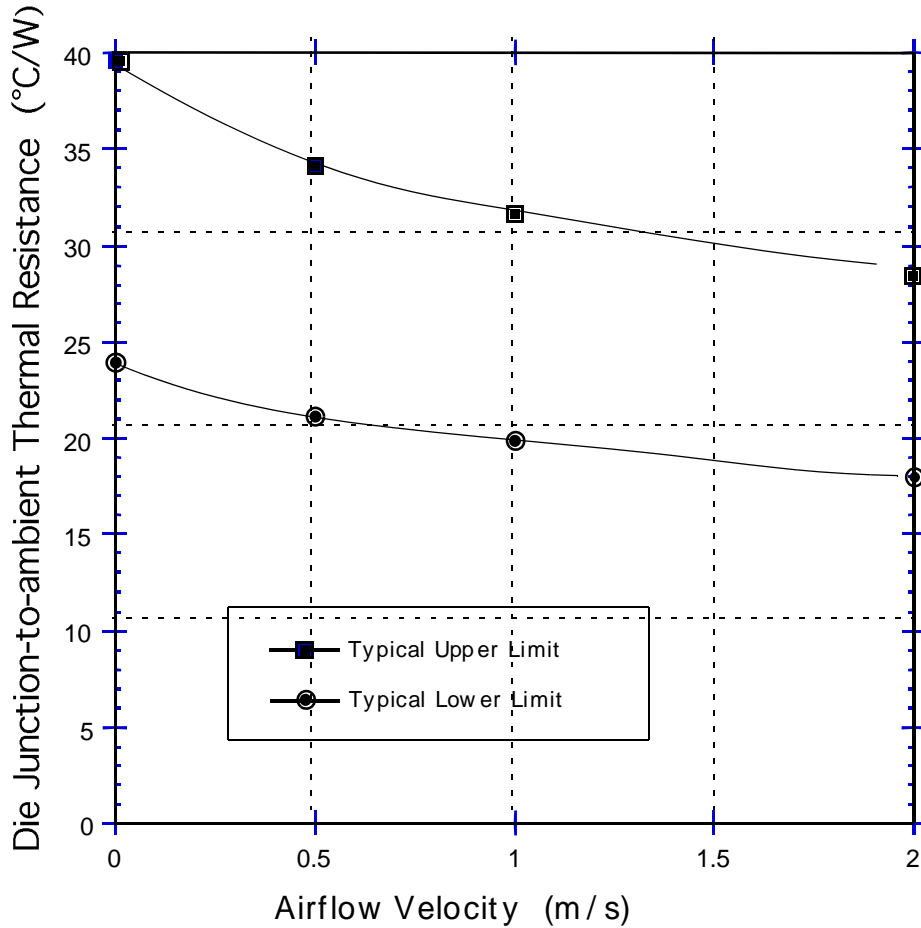

Figure 14. Typical Die Junction-to-Ambient Thermal Resistance (21 mm CBGA and 23 mm WB-PBGA)

To reduce the die-junction temperature, heat sinks may be attached to the package by several methods—adhesive, spring clip to holes in the printed-circuit board or package, and mounting clip and screw assembly (both CBGA and PBGA packages); see [Figure 15](#).

CAUTION

While choosing a heat sink attachment method, any attachment mechanism should not degrade the package structural integrity and/or the package-to-board interconnect reliability. For additional general information, see this paper—*Investigation of Heat Sink Attach Methodologies and the Effects on Package Structural Integrity and Interconnect Reliability*.

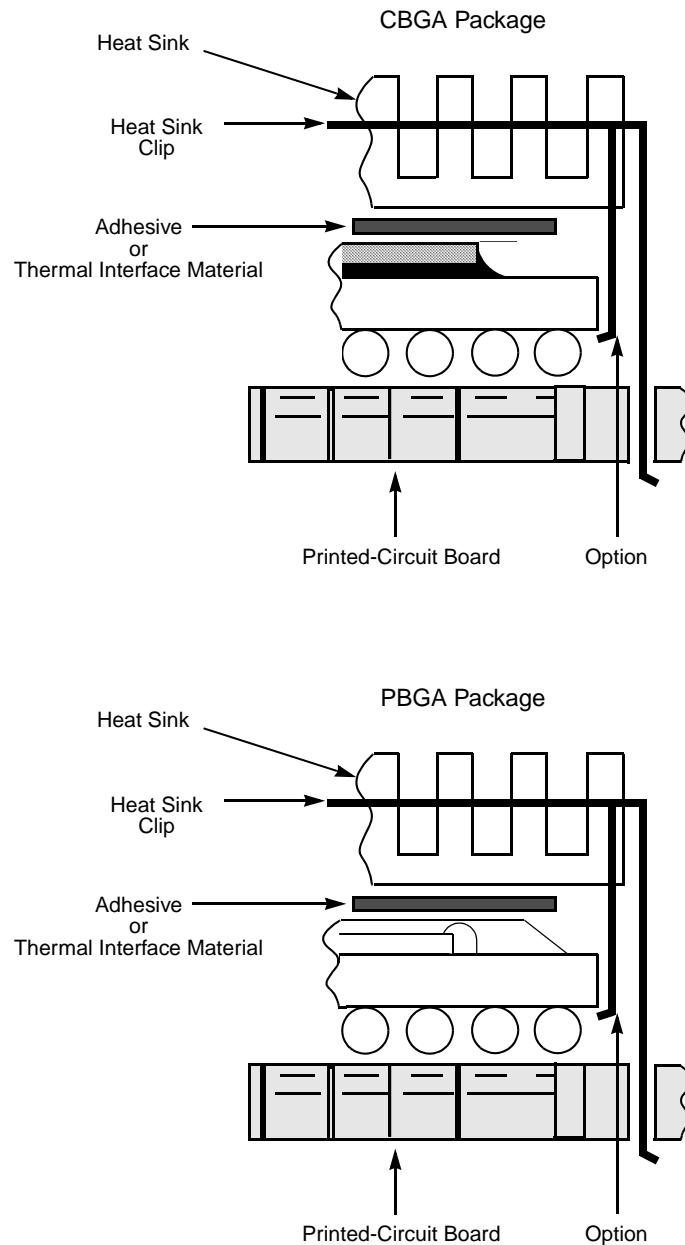

Figure 15. Package Exploded Cross-Sectional View with Heat Sink

The board designer can choose between several types of commercially available heat sinks to place on the 603e. Ultimately, the final selection of an appropriate heat sink depends on many factors, such as thermal performance at a given air velocity, spatial volume, mass, attachment method, assembly, and cost.

8.6.1 Internal Package Conduction Resistance

For this packaging technology, the intrinsic thermal conduction resistance (as shown in [Table 3](#)) versus the external thermal resistance paths are shown in this figure for a package with an attached heat sink mounted to a PCB.

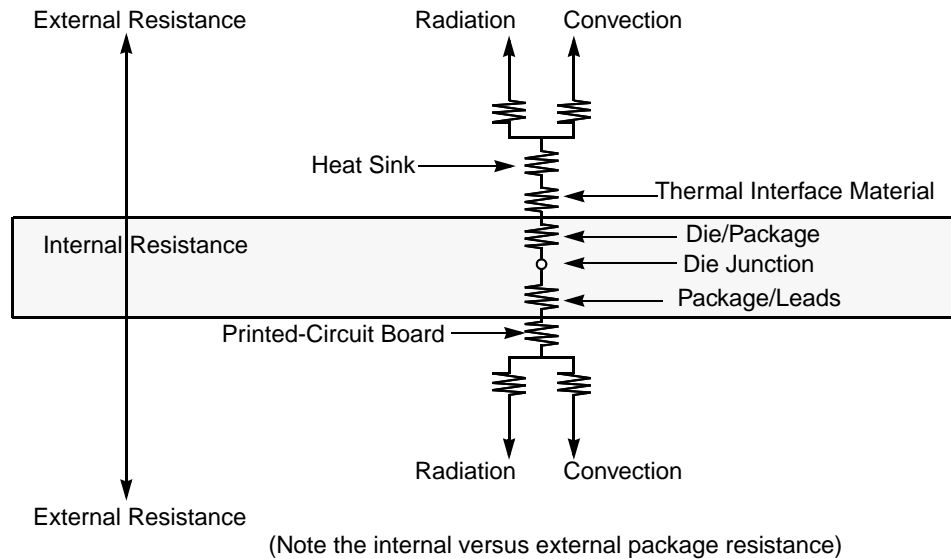

Figure 16. Package with Heat Sink Mounted to a Printed-Circuit Board

8.6.2 Thermal Interface Materials

A thermal interface material is recommended at the package lid-to-heat sink interface to minimize the thermal contact resistance. For those applications where the heat sink is attached by spring clip mechanism, as shown in [Figure 17](#). The thermal performance of three thin-sheet thermal-interface materials (silicone, graphite/oil, fluoroether oil), a bare joint, and a joint with thermal grease as a function of contact pressure. As shown, the performance of these thermal interface materials improves with increasing contact pressure. The use of thermal grease significantly reduces the interface thermal resistance. That is, the bare joint results in a thermal resistance approximately seven times greater than the thermal grease joint. Therefore, the synthetic grease offers the best thermal performance, considering the low-interface pressure. Of course, the selection of any thermal interface material depends on many factors—thermal performance requirements, manufacturability, service temperature, dielectric properties, cost, etc.

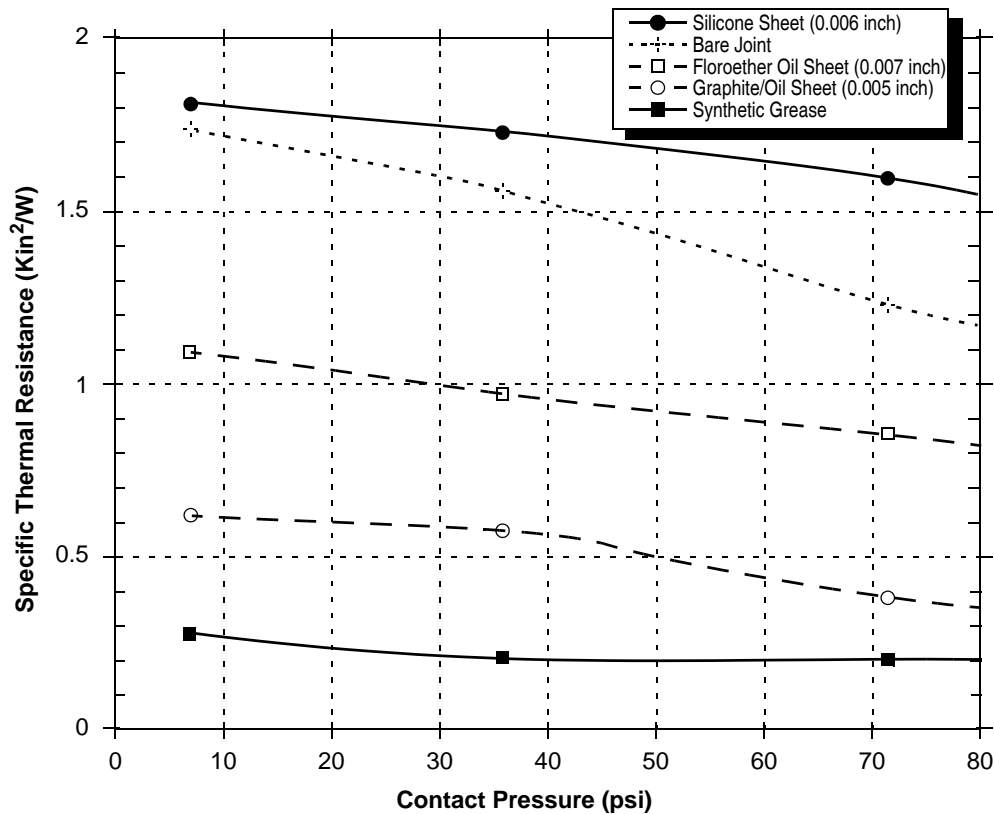

Figure 17. Thermal Performance of Select Thermal Interface Material

The board designer can choose between several types of thermal interface. Heat sink adhesive materials should be selected based upon high conductivity, yet adequate mechanical strength to meet equipment shock/vibration requirements.

8.6.3 Heat Sink Selection Example

For preliminary heat sink sizing, the die-junction temperature can be expressed as follows:

$$T_j = T_a + T_r + (\theta_{jc} + \theta_{int} + \theta_{sa}) * P_d \quad \text{Eqn. 1}$$

where:

T_j is the die-junction temperature

T_a is the inlet cabinet ambient temperature

T_r is the air temperature rise within the computer cabinet

θ_{jc} is the die junction-to-case thermal resistance

θ_{int} is the adhesive or interface material thermal resistance

θ_{sa} is the heat sink base-to-ambient thermal resistance

P_d is the power dissipated by the device

During operation the die-junction temperatures (T_j) should be maintained less than the value specified in Table 3. The temperature of the air cooling the component greatly depends upon the ambient inlet air temperature and the air temperature rise within the electronic cabinet. An electronic cabinet inlet-air temperature (T_a) may range from 30 to 40 °C. The air temperature rise within a cabinet (T_r) may be in the range of 5 to 10 °C. The thermal resistance of the thermal interface material (θ_{int}) is typically about 1 °C/W. Assuming a T_a of 30 °C, a T_r of 5 °C a CBGA package $\theta_{jc} = 0.095$, and a power consumption (P_d) of 3.0 Watts, the following expression for T_j is obtained:

Die-junction temperature: $T_j = 30\text{ °C} + 5\text{ °C} + (0.095\text{ °C/W} + 1.0\text{ °C/W} + R_{sa}) * 3.0\text{ W}$. For example, the heat sink-to-ambient thermal resistance (R_{sa}) versus airflow velocity is shown in this figure.

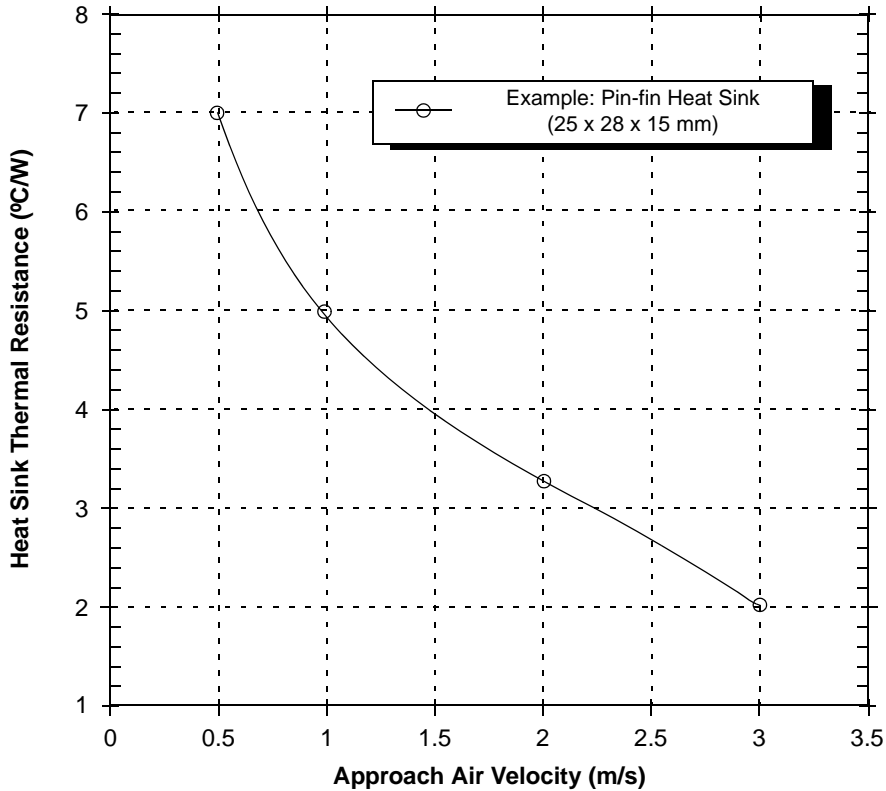

Figure 18. Example of Heat Sink-to-Ambient Thermal Resistance Versus Airflow Velocity

Assuming an air velocity of 0.5 m/s, we have an effective R_{sa} of 7 °C/W, thus

$$T_j = 30\text{ °C} + 5\text{ °C} + (0.095\text{ °C/W} + 1.0\text{ °C/W} + 7\text{ °C/W}) * 3.0\text{ W}, \tag{Eqn. 2}$$

resulting in a die-junction temperature of approximately 60 °C which is well within the maximum operating temperature of the component.

For a PBGA package, and assuming a T_a of 30 °C, a T_r of 5 °C a PBGA package $\theta_{jc} = 8$, and a power consumption (P_d) of 3.0 Watts, the following expression for die-junction temperature, T_j , is obtained as:

$$T_j = 30\text{ °C} + 5\text{ °C} + (8\text{ °C/W} + 1.0\text{ °C/W} + R_{sa}) * 3.0\text{ W} \tag{Eqn. 3}$$

Assuming an air velocity of 0.5 m/s, we have an effective R_{sa} of 7 °C/W, thus

$$T_j = 30^{\circ}\text{C} + 5^{\circ}\text{C} + (8^{\circ}\text{C/W} + 1.0^{\circ}\text{C/W} + 7^{\circ}\text{C/W}) * 3.0\text{ W}, \quad \text{Eqn. 4}$$

resulting in a die-junction temperature of approximately 83 °C that is well within the maximum operating temperature of the component. Commercially available heat sinks have different heat sink-to-ambient thermal resistances, and may or may not need air flow.

Though the die junction-to-ambient and the heat sink-to-ambient thermal resistances are a common figure-of-merit used for comparing the thermal performance of various microelectronic packaging technologies, one should exercise caution when only using this metric in determining thermal management because no single parameter can adequately describe three-dimensional heat flow. The final die-junction operating temperature is not only a function of the component-level thermal resistance, but the system-level design and its operating conditions. In addition to the component's power consumption, a number of factors affect the final operating die-junction temperature—airflow, board population (local heat flux of adjacent components), heat sink efficiency, heat sink attach, heat sink placement, next-level interconnect technology, system air temperature rise, altitude, etc.

Due to the complexity and the many variations of system-level boundary conditions for today's microelectronic equipment, the combined effects of the heat transfer mechanisms (radiation, convection, and conduction) may vary widely. For these reasons, we recommend using conjugate heat transfer models for the board, as well as, system-level designs. To expedite system-level thermal analysis, several “compact” thermal-package models are available within FLOTHERM®. These are available upon request.

9 Ordering Information

This figure provides the part numbering nomenclature for the PID7t-603e. Note that the individual part numbers correspond to a maximum processor core frequency. For available frequencies, contact your local Freescale sales office.

In addition to the processor frequency, the part numbering scheme also consists of a part modifier and application modifier. The part modifier indicates any enhancement(s) in the part from the original design. The application modifier may specify special bus frequencies or application conditions. Each part number also contains a revision code. This refers to the die mask revision number and is specified in the part numbering scheme for identification purposes only.

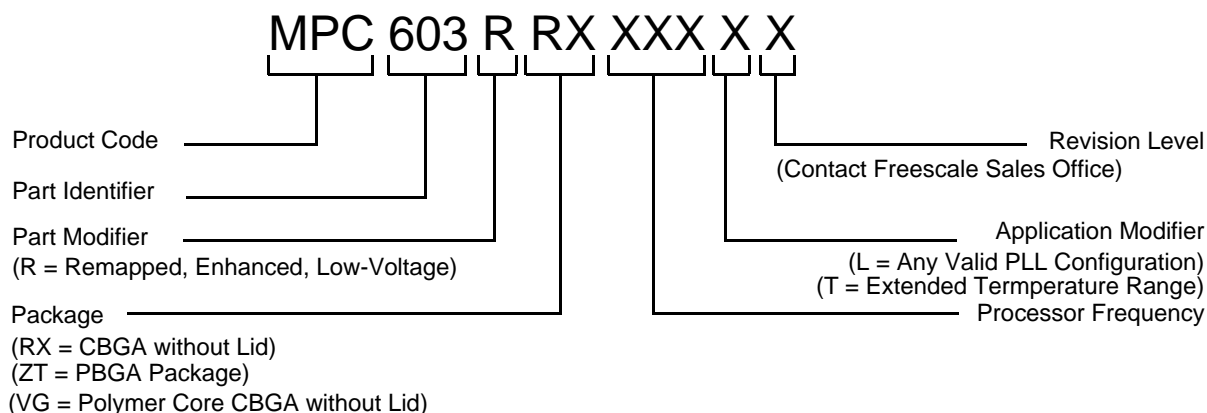

Figure 19. Part Number Key

10 Revision History

This table summarizes revision history for this document.

Table 13. Document Revision History

Rev. Number	Date	Substantive Change(s)
5	9/2011	<ul style="list-style-type: none">• Updated to new Freescale template.• Added package info, VG = Polymer Core CBGA without Lid on Figure 19.• Deleted thermal heat sink and thermal interface vendor details from 8.6/-23 and 8.6.2/-26.

How to Reach Us:

Home Page:

www.freescale.com

email:

support@freescale.com

USA/Europe or Locations Not Listed:

Freescale Semiconductor
Technical Information Center, CH370
1300 N. Alma School Road
Chandler, Arizona 85224
1-800-521-6274
480-768-2130
support@freescale.com

Europe, Middle East, and Africa:

Freescale Halbleiter Deutschland GmbH
Technical Information Center
Schatzbogen 7
81829 Muenchen, Germany
+44 1296 380 456 (English)
+46 8 52200080 (English)
+49 89 92103 559 (German)
+33 1 69 35 48 48 (French)
support@freescale.com

Japan:

Freescale Semiconductor Japan Ltd.
Headquarters
ARCO Tower 15F
1-8-1, Shimo-Meguro, Meguro-ku
Tokyo 153-0064, Japan
0120 191014
+81 3 5437 9125
support.japan@freescale.com

Asia/Pacific:

Freescale Semiconductor Hong Kong Ltd.
Technical Information Center
2 Dai King Street
Tai Po Industrial Estate,
Tai Po, N.T., Hong Kong
+800 2666 8080
support.asia@freescale.com

For Literature Requests Only:

Freescale Semiconductor
Literature Distribution Center
P.O. Box 5405
Denver, Colorado 80217
1-800-441-2447
303-675-2140
Fax: 303-675-2150
LDCForFreescaleSemiconductor
@hibbertgroup.com

Information in this document is provided solely to enable system and software implementers to use Freescale Semiconductor products. There are no express or implied copyright licenses granted hereunder to design or fabricate any integrated circuits or integrated circuits based on the information in this document.

Freescale Semiconductor reserves the right to make changes without further notice to any products herein. Freescale Semiconductor makes no warranty, representation or guarantee regarding the suitability of its products for any particular purpose, nor does Freescale Semiconductor assume any liability arising out of the application or use of any product or circuit, and specifically disclaims any and all liability, including without limitation consequential or incidental damages. "Typical" parameters which may be provided in Freescale Semiconductor data sheets and/or specifications can and do vary in different applications and actual performance may vary over time. All operating parameters, including "Typicals" must be validated for each customer application by customer's technical experts. Freescale Semiconductor does not convey any license under its patent rights nor the rights of others. Freescale Semiconductor products are not designed, intended, or authorized for use as components in systems intended for surgical implant into the body, or other applications intended to support or sustain life, or for any other application in which the failure of the Freescale Semiconductor product could create a situation where personal injury or death may occur. Should Buyer purchase or use Freescale Semiconductor products for any such unintended or unauthorized application, Buyer shall indemnify and hold Freescale Semiconductor and its officers, employees, subsidiaries, affiliates, and distributors harmless against all claims, costs, damages, and expenses, and reasonable attorney fees arising out of, directly or indirectly, any claim of personal injury or death associated with such unintended or unauthorized use, even if such claim alleges that Freescale Semiconductor was negligent regarding the design or manufacture of the part.

Freescale, the Freescale logo, CodeWarrior, PowerQUICC, and StarCore are trademarks of Freescale Semiconductor, Inc. Reg. U.S. Pat. & Tm. Off. QUICC Engine is a trademark of Freescale Semiconductor, Inc. All other product or service names are the property of their respective owners. The Power Architecture and Power.org word marks and the Power and Power.org logos and related marks are trademarks and service marks licensed by Power.org.
© 2011 Freescale Semiconductor, Inc.

Document Number: MPC603E7TEC
Rev. 5
09/2011



X-ON Electronics

Largest Supplier of Electrical and Electronic Components

Click to view similar products for [Microprocessors - MPU category](#):

Click to view products by [Freescale manufacturer](#):

Other Similar products are found below :

[MC68302EH20C](#) [MC7457RX1000LC](#) [MC7457RX1267LC](#) [MC7457VG1267LC](#) [A2C00010998 A](#) [A2C52004004](#) [R5F117BCGNA#20](#)
[R5F52106BDLA#U0](#) [R5S72690W266BG#U0](#) [ADJ3400IAA5DOE](#) [MPC8245TVV266D](#) [MPC8245TZU300D](#) [MPC8260ACVVMHBB](#)
[MPC8323ECVRAFDCA](#) [MPC8323VRADDC](#) [MPC8536ECVJAVLA](#) [BOXNUC5PGYH0AJ](#) [20-668-0024](#) [P1010NSN5DFB](#)
[P2010NSN2MHC](#) [P2020NXE2HHC](#) [P5020NSE7QMB](#) [P5020NSE7TNB](#) [P5020NSE7VNB](#) [LS1020ASN7KQB](#) [LS1020AXN7HNB](#)
[LS1020AXN7KQB](#) [A2C00010729 A](#) [A2C00039344](#) [T1022NSE7MQB](#) [T1022NXN7PQB](#) [T1023NSE7MQA](#) [T1024NXE7PQA](#)
[T1042NSE7MQB](#) [T1042NSN7MQB](#) [T1042NXN7WQB](#) [T2080NSE8TTB](#) [T2080NSN8PTB](#) [T2080NXE8TTB](#) [T2081NXN8TTB](#)
[R5F101AFASP#V0](#) [MC68302CEH20C](#) [TS68040MF33A](#) [MPC8260ACVVMIBB](#) [MPC8280CZUUPEA](#) [MPC8313ECVRAFFC](#)
[MPC8313ECVRAGDC](#) [MPC8313EVRADDC](#) [MPC8313EVRAFFC](#) [MPC8313VRADDC](#)