

## MPC823 AC Electrical Specifications

This document contains detailed information on power considerations, DC/AC electrical characteristics, and AC timing specifications for the MPC823.



**Note:** Visit our website at [www.freescale.com](http://www.freescale.com) if you are using a frequency other than 25, 40, or 50MHz. Our website contains a spreadsheet that you can use to calculate the timing for your specific system frequency.

This device contains circuitry protecting against damage from high-static voltage or electrical fields. However, it is advised that precautions be taken to avoid application of any voltages higher than the maximum-rated voltages to this high-impedance circuit. Reliability of operation is enhanced if unused inputs are tied to an appropriate logic voltage level (either GND or  $V_{CC}$ ).

**MAXIMUM RATINGS (GND = 0V)**

RATING	SYMBOL	VALUE	UNIT
Supply Voltage	VDDH	-0.3 to 4.0	V
	VDD	-0.3 to 4.0	V
	KAPWR	-0.3 to 4.0	V
	VDDSYN	-0.3 to 4.0	V
Input Voltage (JTAG and GPIO)	VIN	-0.3 to 5.8	V
Input Voltage (All other pins)	VIN	-0.3 to 3.3	V
Operating Temperature	T <sub>A</sub>	0 to 70° or -40° to 85°	°C
Storage Temperature Range	T <sub>STG</sub>	-55 to +150	°C
NOTES: 1. Functional operating conditions are given in <b>DC Electrical Characteristics (VCC = 3.0 - 3.6 V)</b> . Absolute maximum ratings are stress ratings only, and functional operation at the maxima is not guaranteed. Stress beyond those listed may affect device reliability or cause permanent damage to the device. 2. <b>CAUTION:</b> The JTAG and GPIO input voltages cannot be more than 2.5 V greater than supply voltage, this restriction applies also on “power-on” as well as on normal operation. 3. 5 Volt friendly inputs are inputs that tolerate 5 volts for JTAG and GPIO pins. 4. If you are using Mask Revision Base #F98S (Revision 0), all pins except EXTAL and CLK4IN are 5V tolerant inputs.			

**THERMAL CHARACTERISTICS**

CHARACTERISTIC	SYMBOL	VALUE	UNIT
Thermal Resistance for BGA	$\theta_{Jc}$	~30	°C/W

## POWER CONSIDERATIONS

The average chip-junction temperature,  $T_J$ , in °C can be obtained from

$$T_J = T_A + (P_D \cdot q_{JA}) \quad (1)$$

where

- $T_A$  = Ambient Temperature, °C
- $q_{JA}$  = Package Thermal Resistance, Junction to Ambient, °C/W
- $P_D$  =  $P_{INT} + P_{I/O}$
- $P_{INT}$  =  $I_{DD} \times V_{DD}$ , Watts—Chip Internal Power
- $P_{I/O}$  = Power Dissipation on Input and Output Pins—User Determined

For most applications  $P_{I/O} < 0.3 \cdot P_{INT}$  and can be neglected. If  $P_{I/O}$  is neglected, an approximate relationship between  $P_D$  and  $T_J$  is:

$$P_D = K \prod (T_J + 273^\circ\text{C}) \quad (2)$$

Solving equations (1) and (2) for K gives

$$K = \frac{P_D \cdot (T_A + 273^\circ\text{C}) + q_{JA} \cdot P_D^2}{(T_J + 273^\circ\text{C})} \quad (3)$$

where K is a constant pertaining to the particular part. K can be determined from equation (3) by measuring  $P_D$  (at equilibrium) for a known  $T_J$ . Using this value of K, the values of  $P_D$  and  $T_J$  can be obtained by solving equations (1) and (2) iteratively for any value of  $T_A$ .

## Layout Practices

Each  $V_{CC}$  pin on the MPC823 should be provided with a low-impedance path to the board's supply. Each GND pin should be provided with a low-impedance path to ground. The power supply pins drive distinct groups of logic on chip. The  $V_{CC}$  power supply should be bypassed to ground using at least four 0.1  $\mu\text{F}$  bypass capacitors located as close as possible to the four sides of the package. The capacitor leads and associated printed circuit traces connecting to chip  $V_{CC}$  and GND should be kept to less than half an inch per capacitor lead. A four-layer board that employs two inner layers as  $V_{CC}$  and GND planes should be used.

All output pins on the MPC823 have fast rise and fall times. Printed circuit (PC) trace interconnection length should be minimized in order to minimize undershoot and reflections caused by these fast output switching times. This recommendation particularly applies to the address and data busses. Maximum PC trace lengths of six inches are recommended. Capacitance calculations should consider all device loads as well as parasitic capacitances due to the PC traces. Attention to proper PCB layout and bypassing becomes especially critical in systems with higher capacitive loads because these loads create higher transient currents in the  $V_{CC}$  and GND circuits. Pull up all unused inputs or signals that will be inputs during reset. Special care should be taken to minimize the noise levels on the PLL supply pins.



DC ELECTRICAL CHARACTERISTICS ( $V_{CC} = 3.0 - 3.6 V$ )

CHARACTERISTIC	SYMBOL	MIN	MAX	UNIT
Input High Voltage (for JTAG and GPIO)	$V_{IH}$	2.0	5.5	V
Input High Voltage (all other pins)	$V_{IH}$	2.0	3.6	V
Input Low Voltage	$V_{IL}$	GND	0.8	V
EXTAL and EXTCLK Input High Voltage	$V_{IHC}$	$0.7*(V_{CC})$	$V_{CC}+0.3$	V
Input Leakage Current, $V_{IN} = 5.5 V$	$I_{IN}$	—	$\pm 10$	$\mu A$
Hi-z (Off State) Leakage Current, $V_{IN} = 3.5V$	$I_{OZ}$	—	$\pm 10$	$\mu A$
Signal Low Input Current, $V_{IL} = 0.8 V$	$I_L$		$\pm 10$	$\mu A$
Signal High Input Current, $V_{IH} = 2.0 V$	$I_H$		$\pm 10$	$\mu A$
Output High Voltage, $I_{OH} = -2.0 mA$ , $V_{DDH} = 3.0V$ Except XTAL, XFC, and Open-Drain Pins	$V_{OH}$	2.4	—	V
Output Low Voltage $I_{OL} = 2.0 mA$ CLKOUT $I_{OL} = 3.2 mA$ A[6:31], TSIZ0/REG, TSIZ1, D[0:31], DP[0:3]/IRQ[3:6], RD/WR, BURST, RSV/IRQ2, IP_B[0:1]/IWP[0:1]/VFLS[0:1], IP_B2/IOIS16_B/AT2, IP_B3/IWP2/VF2, IP_B4/LWP0/VF0, IP_B5/LWP1/VF1, IP_B6/DSDI/AT0, IP_B7/PTR/AT3, USBRXD/PA15, RXD2/PA13, SMRXD2/L1TXDA/PA9, SMTXD2/L1RXDA/PA8, IRQ4/KR/SPKROUT, TIN1/L1RCLKA/BRGO1/CLK1/PA7, TIN3/TOUT1/CLK2/PA6, TIN2/L1TCLKA/BRGO2/CLK3/PA5, TIN4/TOUT2/CLK4/PA4, LCD_A/SPISEL/PB31, SPICLK/PB30, SPIMOSI/PB29, BRGO3/SPIMISO/PB28, BRGO1/I2CSDA/PB27, BRGO2/I2CSCL/PB26, SMTXD1/PB25, SMRXD1/PB24, SMSYN1/SDACK1/PB23, SMSYN2/SDACK2/PB22, LCD_B/L1ST1/PB19, L1ST2/RTS2/PB18, LCD_C/L1ST3/PB17, L1ST4/L1RQA/PB16, L1ST5/DREQ1/PC15, L1ST6/RTS2/DREQ2/PC14, L1ST7/PC13, L1ST8/L1RQA/PC12, USBRXP/PC11, USBRXN/TGATE1/PC10, CTS2/PC9, TGATE1/CD2/PC8, USBTXP/PC7, USBTXN/PC6, SDACK1/L1TSYNCA/PC5, L1RSYNCA/PC4, LD8/VD7/PD15, LD7/VD6/PD14, LD6/VD5/PD13, LD5/VD4/PD12, LD4/VD3/PD11, LD3/VD2/PD10, LD2/VD1/PD9, LD1/VD0/PD8, FRAME/VSYNCPD5, LCD_AC/LOE/BLANK/PD6, LD0/FIELD/PD7, LOAD/HSYNCPD4, SHIFT/CLK/PD3	$V_{OL}$	—	0.5	V
$I_{OL} = 5.3 mA$ BDIP/GPL_B5, BR, BG, FRZ/IRQ6, CS[0:5], CS6/CE1_B, CS7/CE2_B, WE0/BS_AB0/IORD, WE1/BS_AB1/IOWR, WE2/BS_AB2/PCOE, WE3/BS_AB3/PCWE, GPL_A0/GPL_B0, OE/GPL_A1/GPL_B1, GPL_A[2:3]/GPL_B[2:3]/CS[2:3], UPWAITA/GPL_A4/AS, UPWAITB/GPL_B4, GPL_A5, ALE_B/DSCK/AT1, OP2/MODCK1/STS, OP3/MODCK2/DSDO $I_{OL} = 7.0 mA$ USBOE/PA14, TXD2/PA12 $I_{OL} = 8.9 mA$ TS, TA, TEA, BI, BB, HRESET, SRESET				

NOTE: Input pin voltage specifications are  $V_{CC} = +4 V$  or  $5.8 V$ , whichever is less.  
AC timings are based on a  $50 pF$  load.  
If you are using Mask Revision Base #F98S, all pins except EXTAL and CLK4IN are 5V tolerant inputs.

Freescale Semiconductor, Inc.

AC ELECTRICAL CHARACTERISTICS

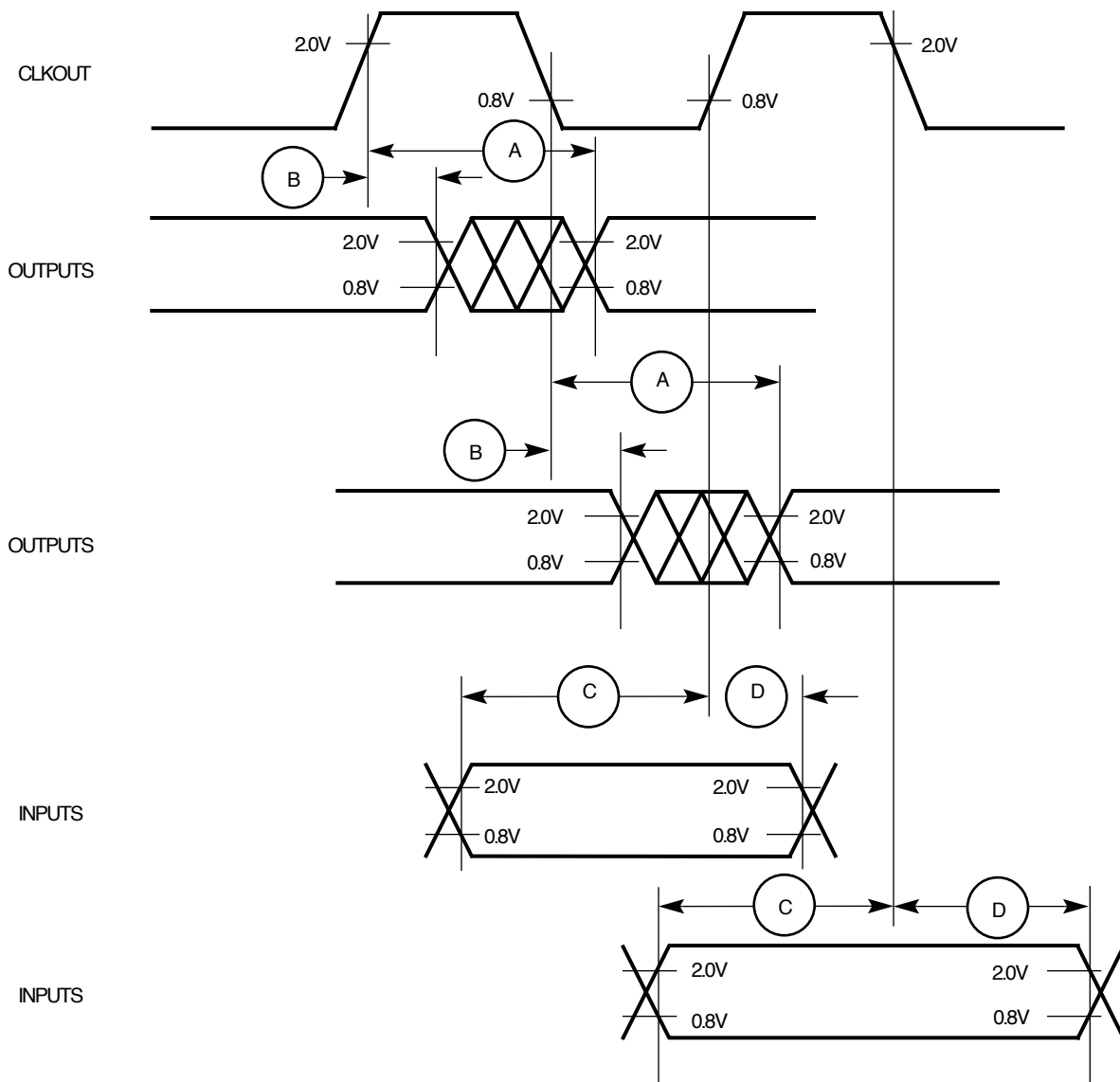

A=MAXIMUM OUTPUT DELAY SPECIFICATION	C=MINIMUM INPUT SETUP TIME SPECIFICATION
B=MINIMUM OUTPUT HOLD TIME	D=MINIMUM INPUT HOLD TIME SPECIFICATION



EXTERNAL BUS ELECTRICAL CHARACTERISTICS

Table 1. Bus Operation Timing

NUM	CHARACTERISTIC	25MHz		40MHz		50MHz		UNIT
		MIN	MAX	MIN	MAX	MIN	MAX	
B1	CLKOUT Period	40	—	25	—	20	—	ns
B1a	EXTCLK to CLKOUT Phase Skew (EXTCLK>15MHz and MF ≤ 2)	-0.9	0.9	-0.9	0.9	-0.9	0.9	ns
B1b	EXTCLK to CLKOUT Phase Skew (EXTCLK>10MHz and MF ≤ 10)	-2.3	2.3	-2.3	2.3	-2.3	2.3	ns
B1c	CLKOUT Phase Jitter (EXTCLK>15MHz and MF≤2)	-0.6	0.6	-0.6	0.6	-0.6	0.6	ns
B1d	CLKOUT Phase Jitter (EXTCLK>10MHz and MF≤10)	-2	2	-2	2	-2	2	ns
B1e	CLKOUT Frequency Jitter (MF<10)	—	0.5	—	0.5	—	0.5	%
B1f	CLKOUT Frequency Jitter (10<MF<500)	—	2	—	2	—	2	%
B1g	CLKOUT Frequency Jitter (MF>500)	—	3	—	3	—	3	%
B1h	Frequency Jitter on EXTCLK	—	0.5	—	0.5	—	0.5	%
B2	Clock Pulse Width Low	16	—	10	—	8	—	ns
B3	Clock Pulse Width High	16	—	10	—	8	—	ns
B4	CLKOUT Rise Time	—	4	—	4	—	4	ns
B5	CLKOUT Fall Time	—	4	—	4	—	4	ns
B6	N/A (Used on Interactive Spreadsheet)							
B7	CLKOUT to A(6:31), RD/WR, BURST, D(0:31), DP(0:3) Invalid	10	—	5	—	5	—	ns
B7a	CLKOUT to TSIZ(0:1), REG, RSV, AT(0:3), BDIP, PTR Invalid	10	—	5	—	5	—	ns
B7b	CLKOUT to BR, BG, FRZ, VFLS(0:1), VF(0:2), IWP(0:2), LWP(0:1), STS Invalid	10	—	5	—	5	—	ns
B8	CLKOUT to A(6:31), RD/WR, BURST, D(0:31), DP(0:3) Valid	10	19	5	13	5	12	ns
B8a	CLKOUT to TSIZ(0:1), REG, RSV, AT(0:3), BDIP, PTR Valid	10	19	5	13	5	12	ns
B8b	CLKOUT to BR, BG, VFLS(0:1), VF(0:2), IWP(0:2), FRZ, LWP(0:1), STS Valid	10	19	5	13	5	12	ns
B9	CLKOUT to A(6:31), RD/WR, BURST, D(0:31), DP(0:3), TSIZ(0:1), REG, RSV, AT(0:3), PTR Hi Z	10	19	5	13	5	12	ns
B10	N/A							
B11	CLKOUT to TS, BB Assertion	10	19	5	12.25	5	12.25	ns
B11a	CLKOUT to TA, BI Assertion (when driven by the Memory Controller or PCMCIA Interface)	2.5	11	2.5	9.25	2.5	9.25	ns
B12	CLKOUT to TS, BB Negation	10	19	5	13	5	12	ns
B12a	CLKOUT to TA, BI Negation (when driven by the Memory Controller or PCMCIA Interface)	2.5	11	2.5	11	2.5	11	ns
B13	CLKOUT to TS, BB Hi Z	10	24	5	21	5	19	ns

**Table 1. Bus Operation Timing (Continued)**

NUM	CHARACTERISTIC	25MHz		40MHz		50MHz		UNIT
		MIN	MAX	MIN	MAX	MIN	MAX	
B13a	CLKOUT to $\overline{TA}$ , $\overline{BI}$ Hi Z (When Driven by the Memory Controller or PCMCIA Interface)	2.5	15	2.5	15	2.5	16	ns
B14	CLKOUT to $\overline{TEA}$ Assertion	2.5	11	2.5	11	2.5	10	ns
B15	CLKOUT to $\overline{TEA}$ Hi Z	2.5	15	2.5	15	2.5	15	ns
B16	$\overline{TA}$ , $\overline{BI}$ Valid to CLKOUT (Setup Time)	9.75	—	9.75	—	9.75	—	ns
B16a	$\overline{TEA}$ , $\overline{KR}$ , $\overline{RETRY}$ Valid to CLKOUT (Setup Time)	11	—	10	—	10	—	ns
B16b	$\overline{BB}$ , $\overline{BG}$ , $\overline{BR}$ Valid to CLKOUT (Setup Time)	8.5	—	8.5	—	8.5	—	ns
B17	CLKOUT to $\overline{TA}$ , $\overline{TEA}$ , $\overline{BI}$ , $\overline{BB}$ , $\overline{BG}$ , $\overline{BR}$ Valid (Hold Time)	1	—	1	—	1	—	ns
B17a	CLKOUT to $\overline{KR}$ , $\overline{RETRY}$ Valid (Hold Time)	2	—	2	—	2	—	ns
B18	D(0:31), DP(0:3) Valid to CLKOUT Rising Edge (Setup Time)	6	—	6	—	6	—	ns
B19	CLKOUT Rising Edge to D(0:31), DP(0:3) Valid (Hold Time)	2	—	2	—	2	—	ns
B20	D(0:31), DP(0:3) Valid to CLKOUT Falling Edge (Setup Time)	4	—	4	—	4	—	ns
B21	CLKOUT Falling Edge to D(0:31), DP(0:3) Valid (Hold Time)	2	—	2	—	2	—	ns
B22	CLKOUT Rising Edge to $\overline{CS}$ Asserted -GPCM- ACS = 00	10	20	5	13	5	13	ns
B22a	CLKOUT Falling Edge to $\overline{CS}$ Asserted -GPCM- ACS = 10, TRLX = 0	—	10	—	8	—	8	ns
B22b	CLKOUT Falling Edge to $\overline{CS}$ Asserted -GPCM- ACS = 11, TRLX = 0, EBDF = 0	10	20	5	13	5	13	ns
B22c	CLKOUT Falling Edge to $\overline{CS}$ Asserted -GPCM- ACS = 11, TRLX = 0, EBDF = 1	14	25	7	16	7	16	ns
B23	CLKOUT Rising Edge to $\overline{CS}$ Negated -GPCM-Read Access - GPCM-Write Access, ACS=00, TRLX=0, CSNT=0	3	10	2	8	2	8	ns
B24	A(6:31) to $\overline{CS}$ Asserted -GPCM- ACS = 10, TRLX = 0	8	—	3	—	3	—	ns
B24a	A(6:31) to $\overline{CS}$ Asserted -GPCM- ACS = 11, TRLX = 0	18	—	8	—	8	—	ns
B25	CLKOUT Rising Edge to $\overline{OE}$ , $\overline{WE}$ (0:3) Asserted	—	11	—	9	—	9	ns
B26	CLKOUT Rising Edge to $\overline{OE}$ Negated	3	11	2	9	2	9	ns
B27	A(6:31) to $\overline{CS}$ Asserted -GPCM- ACS = 10, TRLX = 1	48	—	23	—	23	—	ns
B27a	A(6:31) to $\overline{CS}$ Asserted -GPCM- ACS = 11, TRLX = 1	58	—	28	—	28	—	ns
B28	CLKOUT Rising Edge to $\overline{WE}$ (0:3) Negated -GPCM-Write Access CSNT = '0'	—	11	—	9	—	9	ns
B28a	CLKOUT Falling Edge to $\overline{WE}$ (0:3) Negated -GPCM-Write Access TRLX = '0', CSNT = '1', EBDF=0	10	20	5	13	5	13	ns
B28b	CLKOUT Falling Edge to $\overline{CS}$ Negated -GPCM-Write Access TRLX = '0', CSNT = '1', ACS = '10' or ACS='11', EBDF = 0	—	20	—	13	—	13	ns



Table 1. Bus Operation Timing (Continued)

NUM	CHARACTERISTIC	25MHz		40MHz		50MHz		UNIT
		MIN	MAX	MIN	MAX	MIN	MAX	
B28c	CLKOUT Falling Edge to $\overline{WE}(0:3)$ Negated -GPCM-Write Access TRLX = '0', CSNT = '1', EBDF=1	14	25	7	16	7	16	ns
B28d	CLKOUT Falling Edge to $\overline{CS}$ Negated -GPCM-Write Access TRLX = '0', CSNT = '1', ACS = '10' or ACS='11', EBDF = 1	—	25	—	16	—	16	ns
B29	$\overline{WE}(0:3)$ Negated to D(0:31), DP(0:3) Hi Z -GPCM- Write Access, CSNT = '0'	8	—	3	—	3	—	ns
B29a	$\overline{WE}(0:3)$ Negated to D(0:31), DP(0:3) Hi Z -GPCM- Write Access, TRLX = '0', CSNT = '1', EBDF = 0	18	—	8	—	8	—	ns
B29b	$\overline{CS}$ Negated to D(0:31), DP(0:3) Hi Z -GPCM- Write Access, ACS = '00', TRLX = '0' & CSNT = '0'	8	—	3	—	3	—	ns
B29c	$\overline{CS}$ Negated to D(0:31), DP(0:3) Hi Z -GPCM- Write Access, TRLX = '0', CSNT = '1', ACS = '10' or ACS='11', EBDF = 0	18	—	8	—	8	—	ns
B29d	$\overline{WE}(0:3)$ Negated to D(0:31), DP(0:3) Hi Z -GPCM- Write Access, TRLX = '1', CSNT = '1', EBDF = 0	58	—	28	—	28	—	ns
B29e	$\overline{CS}$ Negated to D(0:31), DP(0:3) Hi Z -GPCM- Write Access, TRLX = '1', CSNT = '1', ACS = '10' or ACS='11', EBDF = 0	58	—	28	—	28	—	ns
B29f	$\overline{WE}(0:3)$ Negated to D(0:31), DP(0:3) Hi Z -GPCM- Write Access, TRLX = '0', CSNT = '1', EBDF = 1	12	—	5	—	5	—	ns
B29g	$\overline{CS}$ Negated to D(0:31), DP(0:3) Hi Z -GPCM- Write Access, TRLX = '0', CSNT = '1', ACS = '10' or ACS='11', EBDF = 1	12	—	5	—	5	—	ns
B29h	$\overline{WE}(0:3)$ Negated to D(0:31), DP(0:3) Hi Z -GPCM- Write Access, TRLX = '1', CSNT = '1', EBDF = 1	52	—	24	—	24	—	ns
B29i	$\overline{CS}$ Negated to D(0:31), DP(0:3) Hi Z -GPCM- Write Access, TRLX = '1', CSNT = '1', ACS = '10' or ACS='11', EBDF = 1	52	—	24	—	24	—	ns
B30	$\overline{CS}$ , $\overline{WE}(0:3)$ Negated to A(6:31) invalid -GPCM- Write Access.	8	—	3	—	3	—	
B30a	$\overline{WE}(0:3)$ Negated to A(6:31) Invalid -GPCM- Write Access, TRLX='0', CSNT = '1'. $\overline{CS}$ Negated to A(6:31) Invalid -GPCM- Write Access, TRLX='0', CSNT = '1', ACS = 10, ACS = '11', EBDF = 0	18	—	8	—	8	—	ns
B30b	$\overline{WE}(0:3)$ Negated to A(6:31) Invalid -GPCM- Write Access, TRLX='1', CSNT = '1'. $\overline{CS}$ Negated to A(6:31) Invalid -GPCM- Write Access, TRLX='1', CSNT = '1', ACS = 10, ACS = '11', EBDF = 0	58	—	28	—	28	—	ns
B30c	$\overline{WE}(0:3)$ Negated to A(6:31) Invalid -GPCM- Write Access, TRLX='0', CSNT = '1'. $\overline{CS}$ Negated to A(6:31) Invalid -GPCM- Write Access, TRLX='0', CSNT = '1', ACS = 10, ACS = '11', EBDF = 1	12	—	4	—	4	—	ns
B30d	$\overline{WE}(0:3)$ Negated to A(6:31) Invalid -GPCM- Write Access, TRLX='1', CSNT = '1'. $\overline{CS}$ Negated to A(6:31) Invalid -GPCM- Write Access, TRLX='1', CSNT = '1', ACS = 10, ACS = '11', EBDF = 1	52	—	24	—	24	—	ns
B31	CLKOUT Falling Edge to $\overline{CS}$ valid as requested by CST4 in the corresponding word of the UPM	1.5	10	1.5	8	1.5	8	ns



**Table 1. Bus Operation Timing (Continued)**

NUM	CHARACTERISTIC	25MHz		40MHz		50MHz		UNIT
		MIN	MAX	MIN	MAX	MIN	MAX	
B31a	CLKOUT Falling Edge to $\overline{CS}$ valid as requested by CST1 in the corresponding word of the UPM, EBDF = 0	10	20	5	13	5	13	ns
B31b	CLKOUT Rising Edge to $\overline{CS}$ valid as requested by CST2 in the corresponding word of the UPM	1.5	10	1.5	8	1.5	8	ns
B31c	CLKOUT Rising Edge to $\overline{CS}$ valid as requested by CST3 in the corresponding word of the UPM	10	20	5	13	5	13	ns
B31d	CLKOUT Falling Edge to $\overline{CS}$ valid as requested by CST1 in the corresponding word of the UPM, EBDF = 1	10	25	5	16	5	16	ns
B32	CLKOUT Falling Edge to $\overline{BS}$ valid as requested by BST4 in the corresponding word of the UPM	1.5	10	1.5	8	1.5	8	ns
B32a	CLKOUT Falling Edge to $\overline{BS}$ valid as requested by BST1 in the corresponding word of the UPM, EBDF = 0	10	20	5	13	5	13	ns
B32b	CLKOUT Rising Edge to $\overline{BS}$ valid as requested by BST2 in the corresponding word of the UPM	1.5	10	1.5	8	1.5	8	ns
B32c	CLKOUT Rising Edge to $\overline{BS}$ valid as requested by BST3 in the corresponding word of the UPM	10	20	5	13	5	13	ns
B32d	CLKOUT Falling Edge to $\overline{BS}$ valid as requested by BST1 in the corresponding word of the UPM, EBDF = 1	10	25	5	16	5	16	ns
B33	CLKOUT Falling Edge to $\overline{GPL}$ valid as requested by GxT4 in the corresponding word of the UPM	1.5	10	1.5	8	1.5	8	ns
B33a	CLKOUT Rising Edge to $\overline{GPL}$ valid as requested by GxT3 in the corresponding word of the UPM	10	20	5	13	5	13	ns
B34	A(6:31) and D(0:31) to $\overline{CS}$ valid as requested by CST4 in the corresponding word of the UPM	8	—	3	—	3	—	ns
B34a	A(6:31) and D(0:31) to $\overline{CS}$ valid as requested by CST1 in the corresponding word of the UPM	18	—	8	—	8	—	ns
B34b	A(6:31) and D(0:31) to $\overline{CS}$ valid as requested by CST2 in the corresponding word of the UPM	28	—	13	—	13	—	ns
B35	A(6:31) and D(0:31) to $\overline{BS}$ valid as requested by BST4 in the corresponding word of the UPM	8	—	3	—	3	—	ns
B35a	A(6:31) and D(0:31) to $\overline{BS}$ valid as requested by BST1 in the corresponding word of the UPM	18	—	8	—	8	—	ns
B35b	A(6:31) and D(0:31) to $\overline{BS}$ valid as requested by BST2 in the corresponding word of the UPM	28	—	13	—	13	—	ns
B36	A(6:31) and D(0:31) to $\overline{GPL}$ valid as requested by GxT4 in the corresponding word of the UPM	8	—	3	—	3	—	ns
B37	UPWAIT Valid to CLKOUT Falling Edge	6	—	6	—	6	—	ns
B38	CLKOUT Falling Edge to UPWAIT Valid	1	—	1	—	1	—	ns
B39	$\overline{AS}$ Valid to CLKOUT Rising Edge	9	—	7	—	7	—	ns

**Table 1. Bus Operation Timing (Continued)**

NUM	CHARACTERISTIC	25MHz		40MHz		50MHz		UNIT
		MIN	MAX	MIN	MAX	MIN	MAX	
B40	A(6:31), TSIZ(0:1), RD $\overline{WR}$ , $\overline{BURST}$ , Valid to CLKOUT Rising Edge	9	—	7	—	7	—	ns
B41	$\overline{TS}$ Valid to CLKOUT Rising Edge (Setup Time)	9	—	7	—	7	—	ns
B42	CLKOUT Rising Edge to $\overline{TS}$ Valid (Hold Time)	2	—	2	—	2	—	ns
B43	$\overline{AS}$ Negation to Memory Controller Signals Negation	—	13	—	13	—	13	ns

NOTES:

1. The timing for  $\overline{BR}$  output is relevant when the MPC823 is selected to work with the external bus arbiter. The timing for  $\overline{BG}$  output is relevant when the MPC823 is selected to work with the internal bus arbiter.
2. The setup times required for  $\overline{TA}$ ,  $\overline{TEA}$  and  $\overline{BI}$  are relevant only when they are supplied by an external device (and not when the memory controller or the PCMCIA interface drive them).
3. The timing required for  $\overline{BR}$  input is relevant when the MPC823 is selected to work with the internal bus arbiter. The timing for  $\overline{BG}$  input is relevant when the MPC823 is selected to work with the external bus arbiter.
4. The D(0:31) and DP(0:3) input timings B18 and B19 refer to the rising edge of the CLKOUT in which the  $\overline{TA}$  input signal is asserted.
5. The D(0:31) and DP(0:3) input timings B20 and B21 refer to the falling edge of the CLKOUT. This timing is valid only under control of the UPM in the memory controller.
6. The timing B30 refers to  $\overline{CS}$  when ACS = '00' and to  $\overline{WE}(0:3)$  when CSNT = '0'.
7. The signal UPWAIT is considered asynchronous to the CLKOUT and synchronized internally. The timings specified in B37 and B38 are specified to enable the freeze of the UPM output signals.
8. The  $\overline{AS}$  signal is considered asynchronous to the CLKOUT signal.

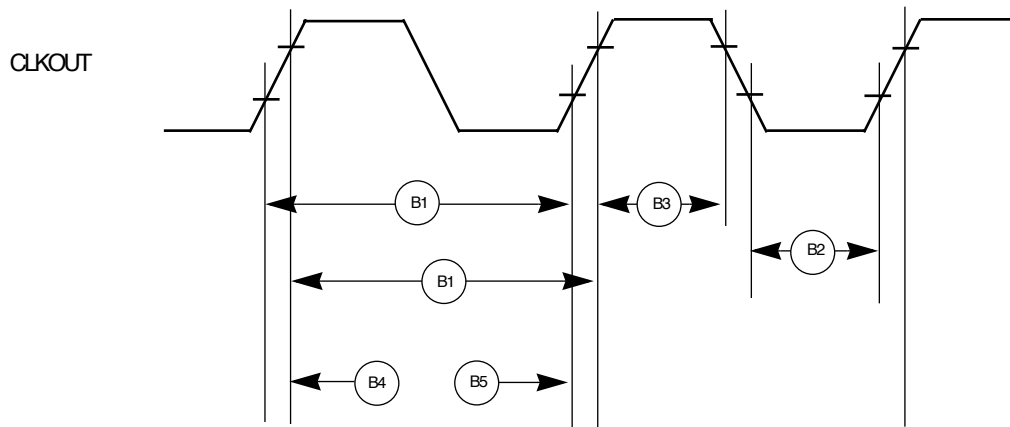

**Figure 1. External Clock Timing Diagram**

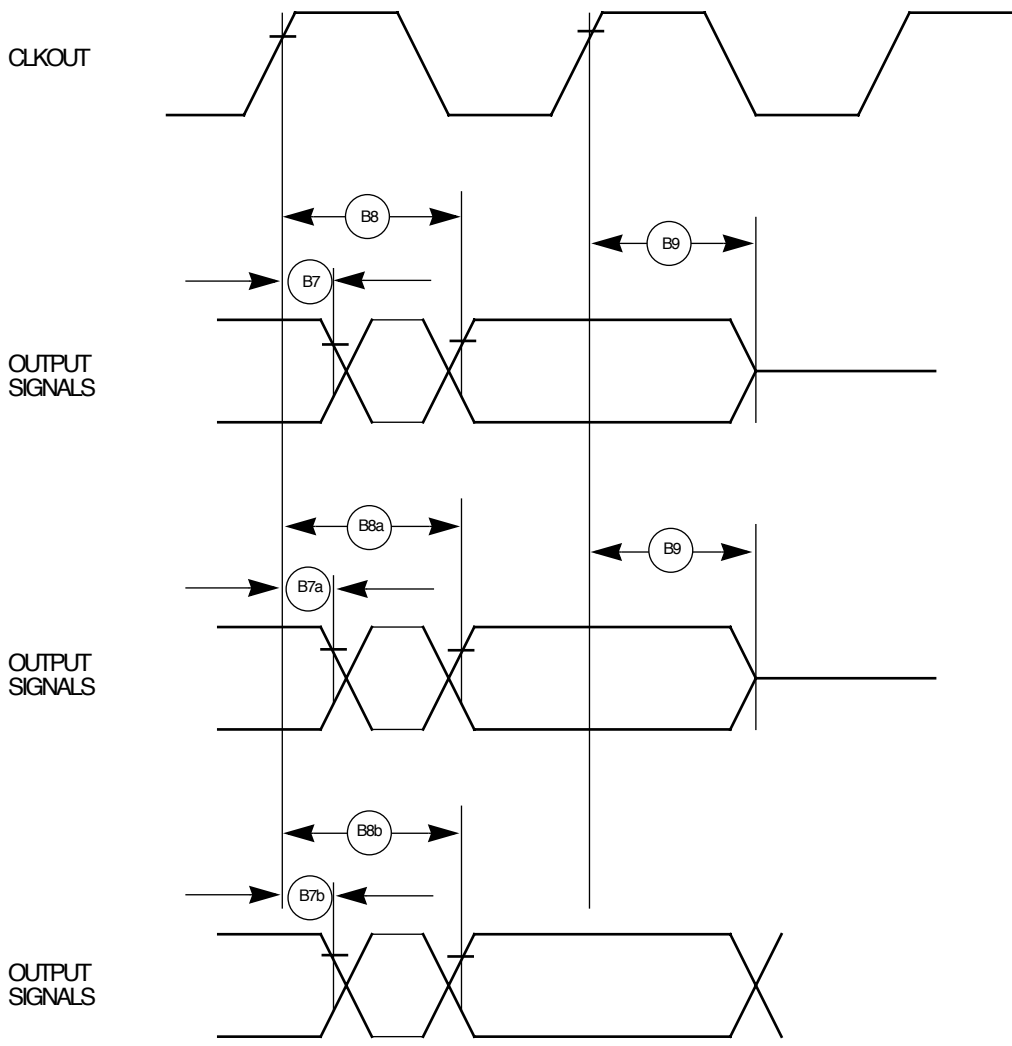
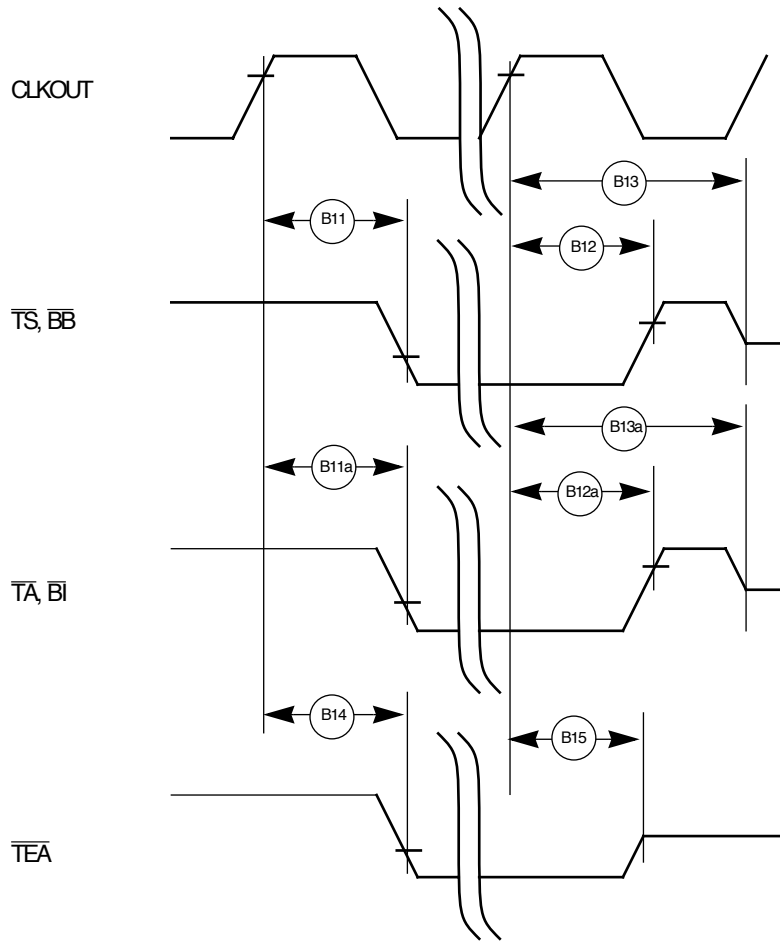

Figure 2. Synchronous Output Signals Timing Diagram



**Figure 3. Synchronous Active Pull-Up and Open-Drain Outputs Signals Timing Diagram**

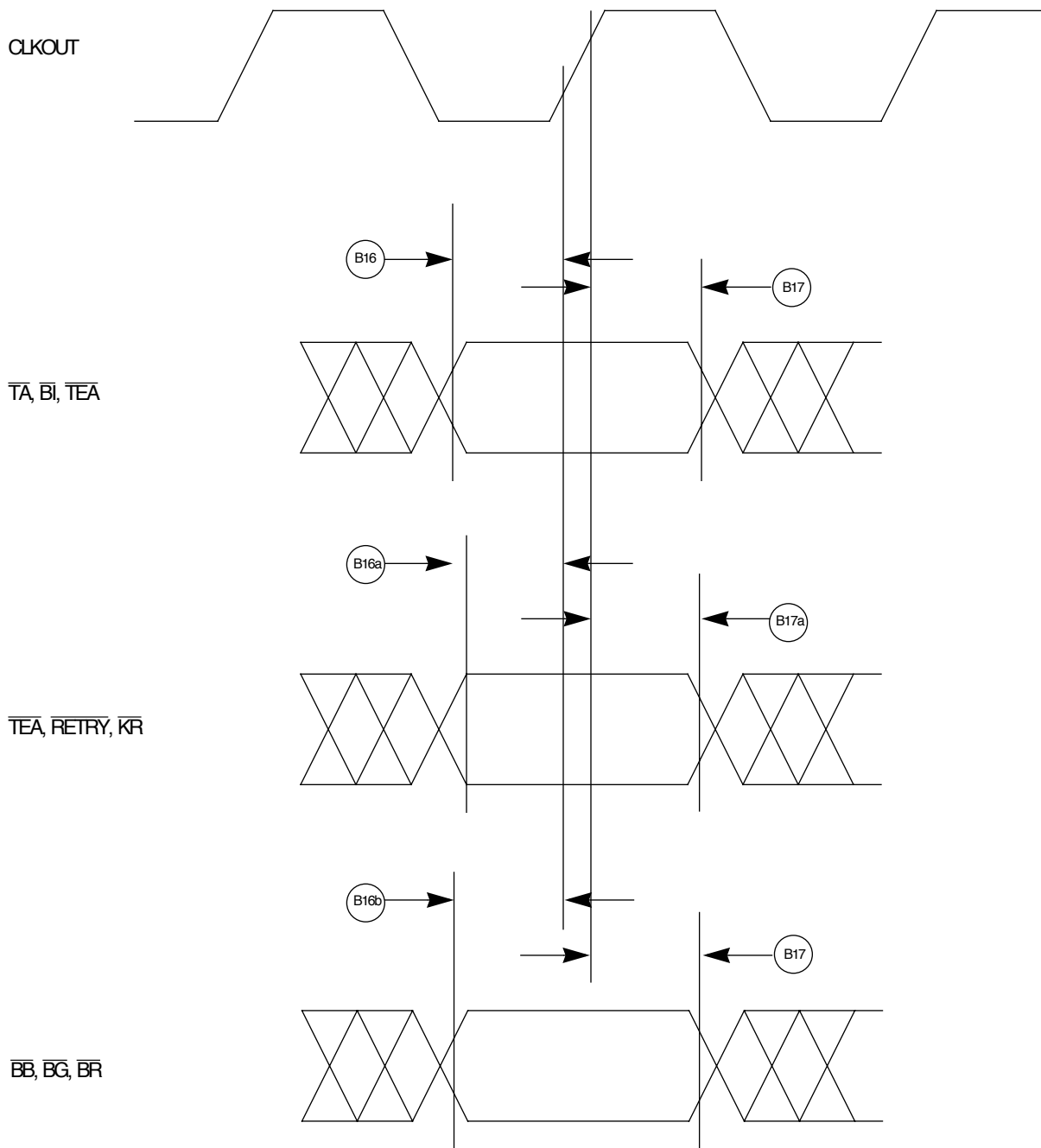
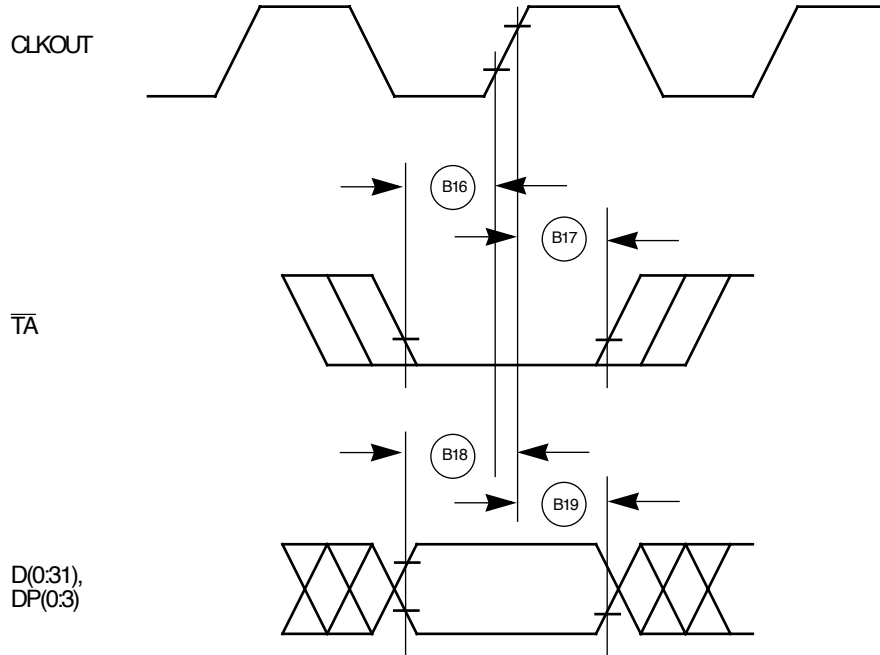
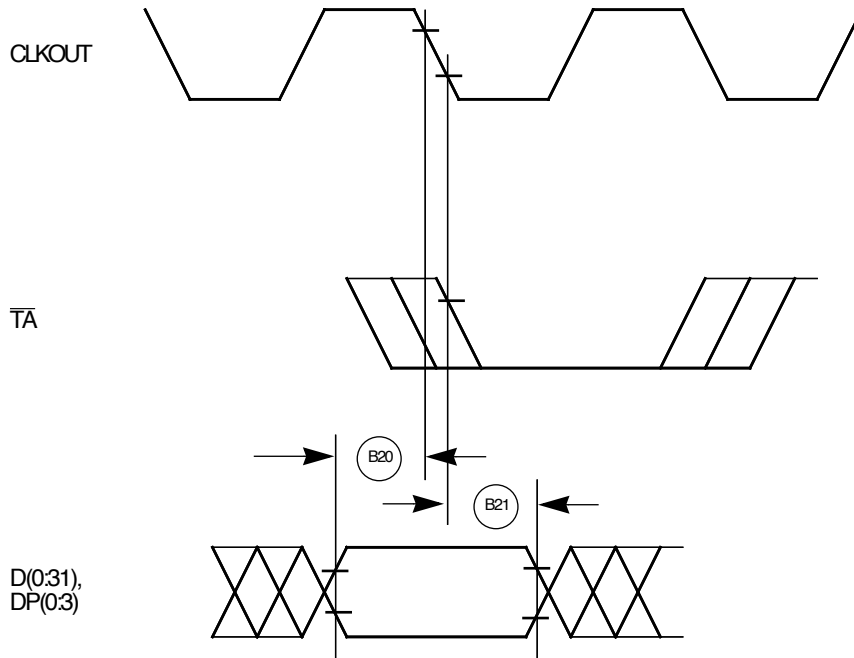

Figure 4. Synchronous Input Signals Timing Diagram



**Figure 5. Input Data In Normal Case Timing Diagram**



**Figure 6. Input Data When Controlled by the UPM Timing Diagram**

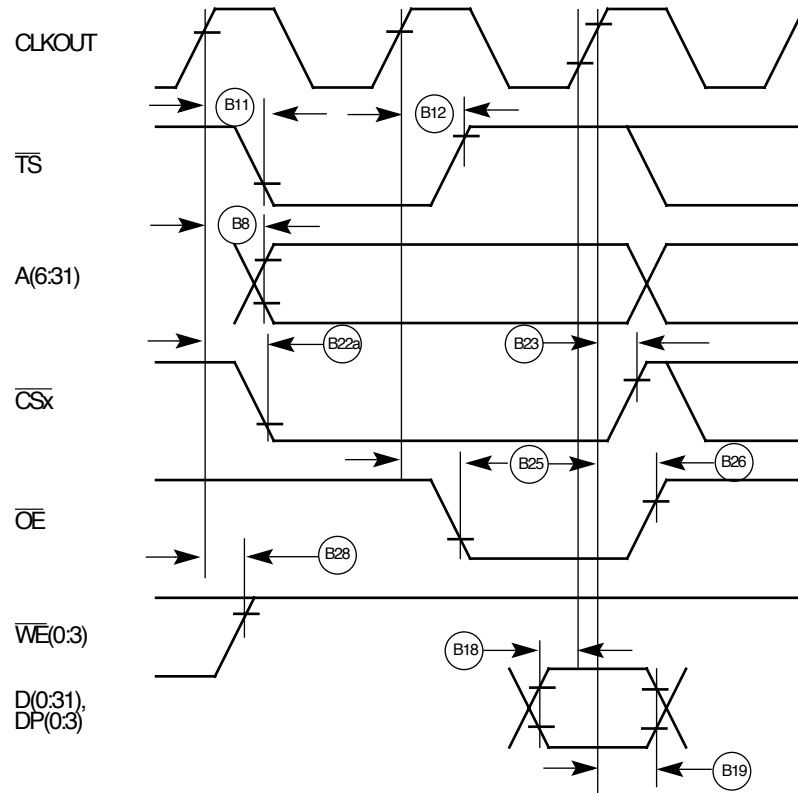

Figure 7. External Bus Read Timing Diagram (GPCM Controlled-ACS = '00')

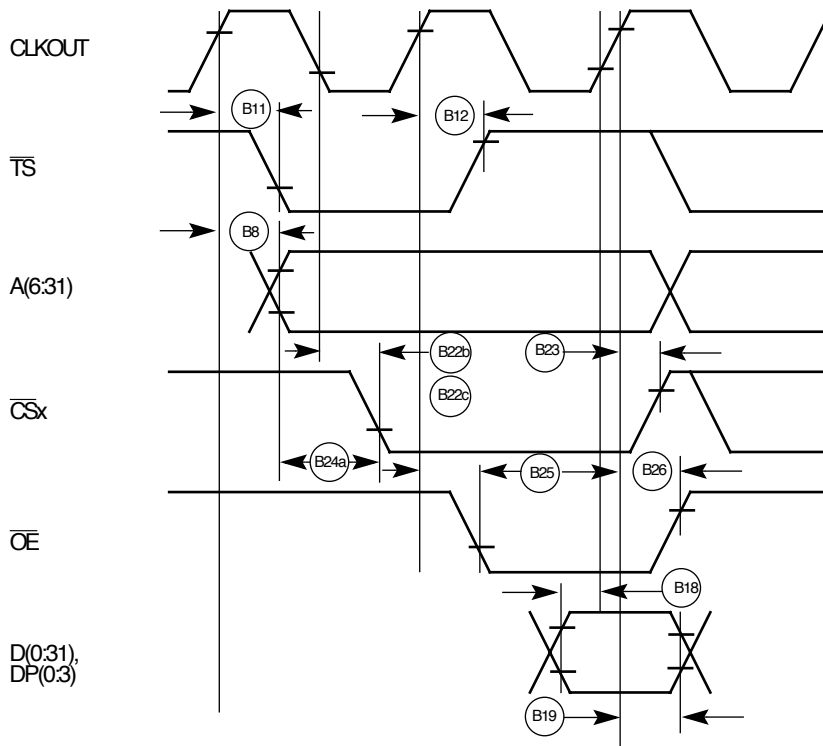
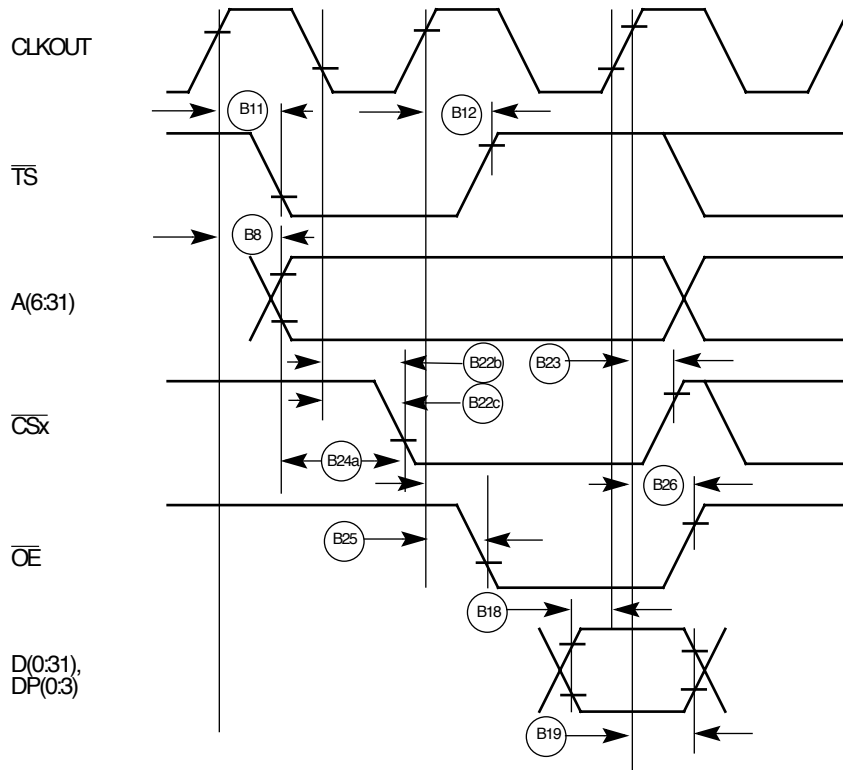
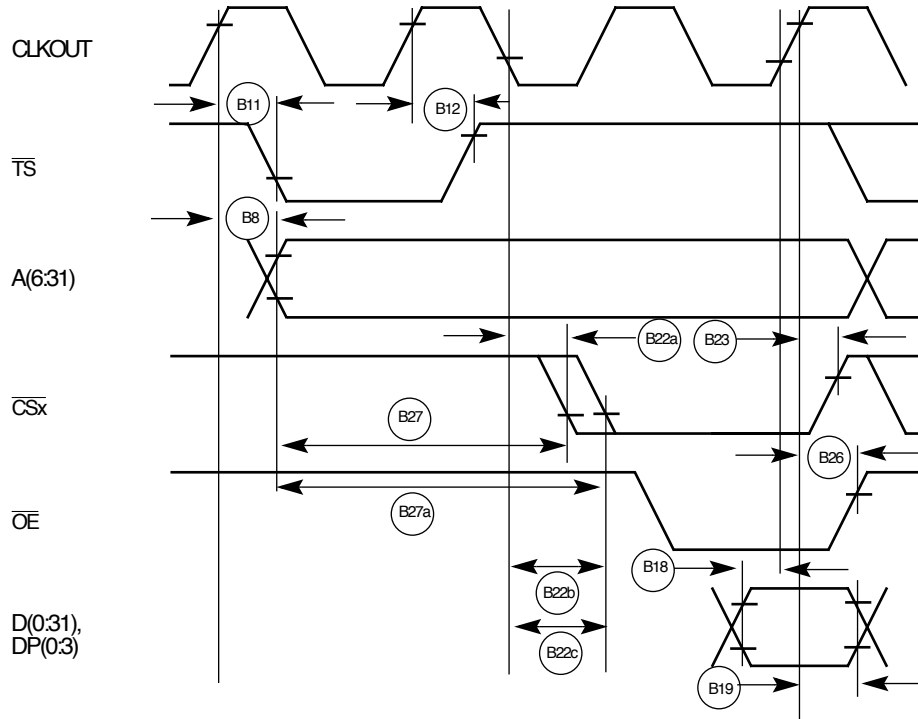

Figure 8. External Bus Read Timing Diagram (GPCM Controlled-TRLX = '0', ACS = '10')



**Figure 9. External Bus Read Timing Diagram  
(GPCM Controlled—TRLX = '0', ACS = '11')**





**Figure 10. External Bus Read Timing Diagram**  
 (GPCM Controlled—TRLX = '1', ACS = '10', ACS = '11')

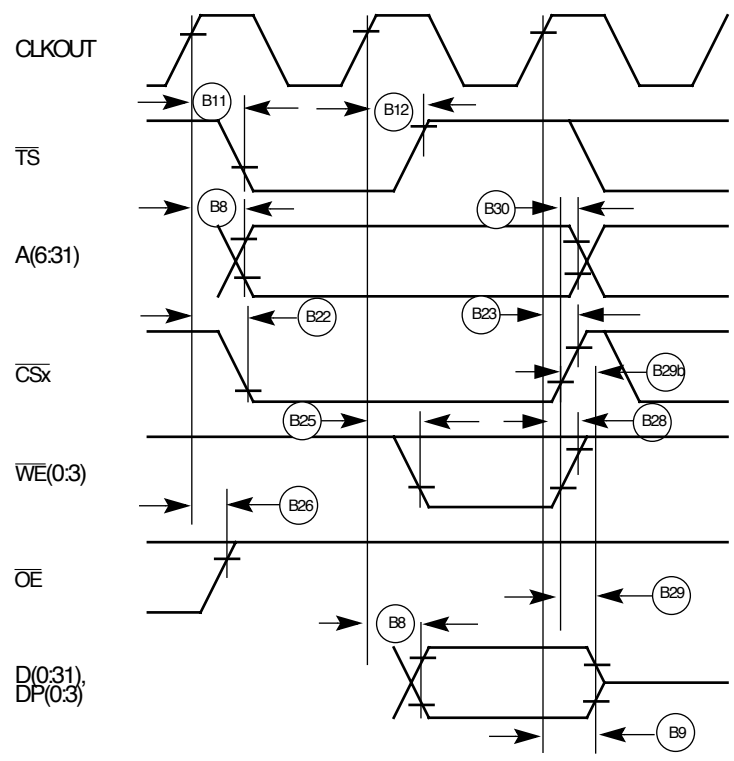

Figure 11. External Bus Write Timing Diagram (GPCM Controlled—TRLX = '0', CSNT = '0')

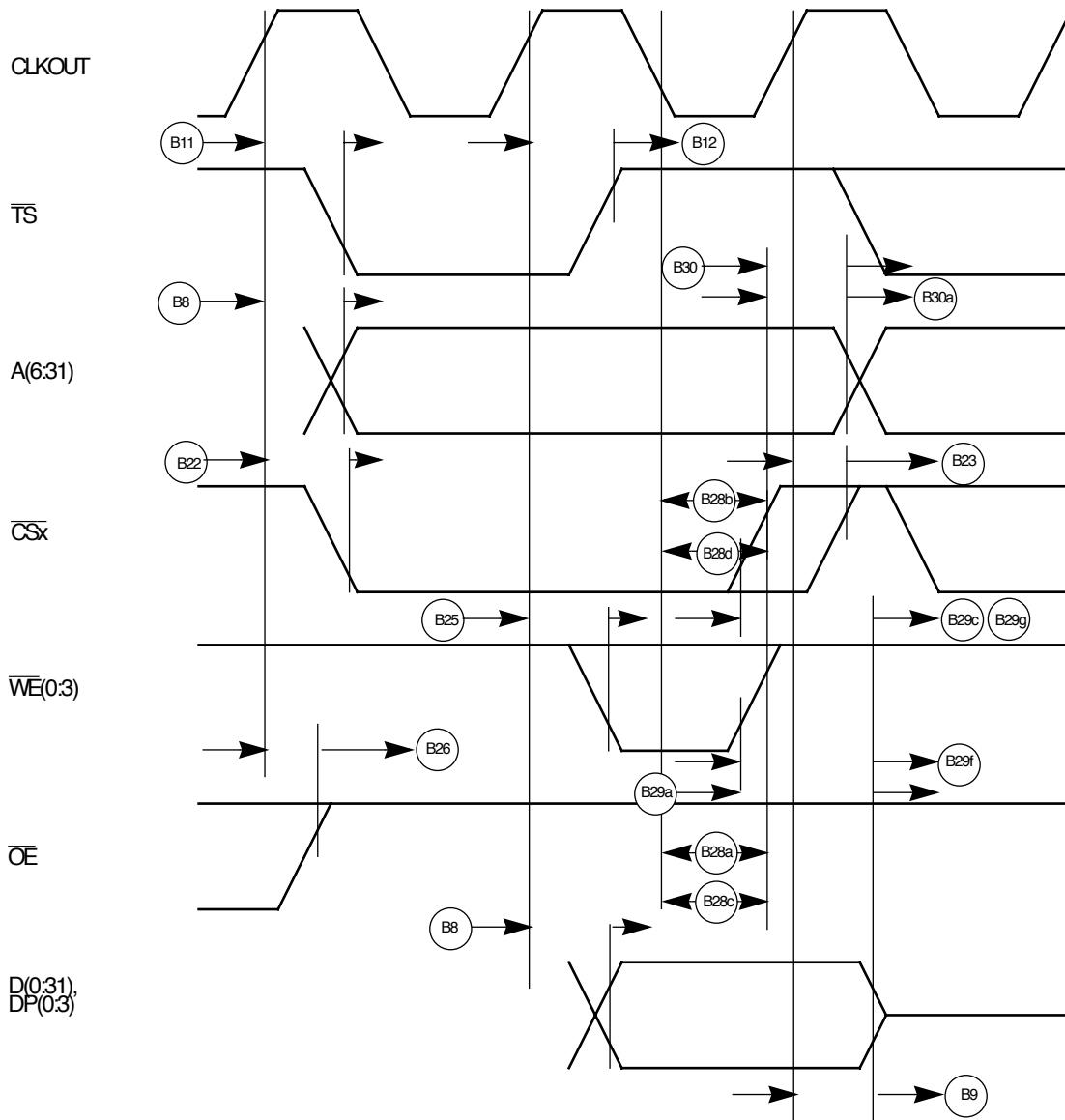

Figure 12. External Bus Write Timing Diagram  
(GPCM Controlled—TRLX = '0', CSNT = '1')

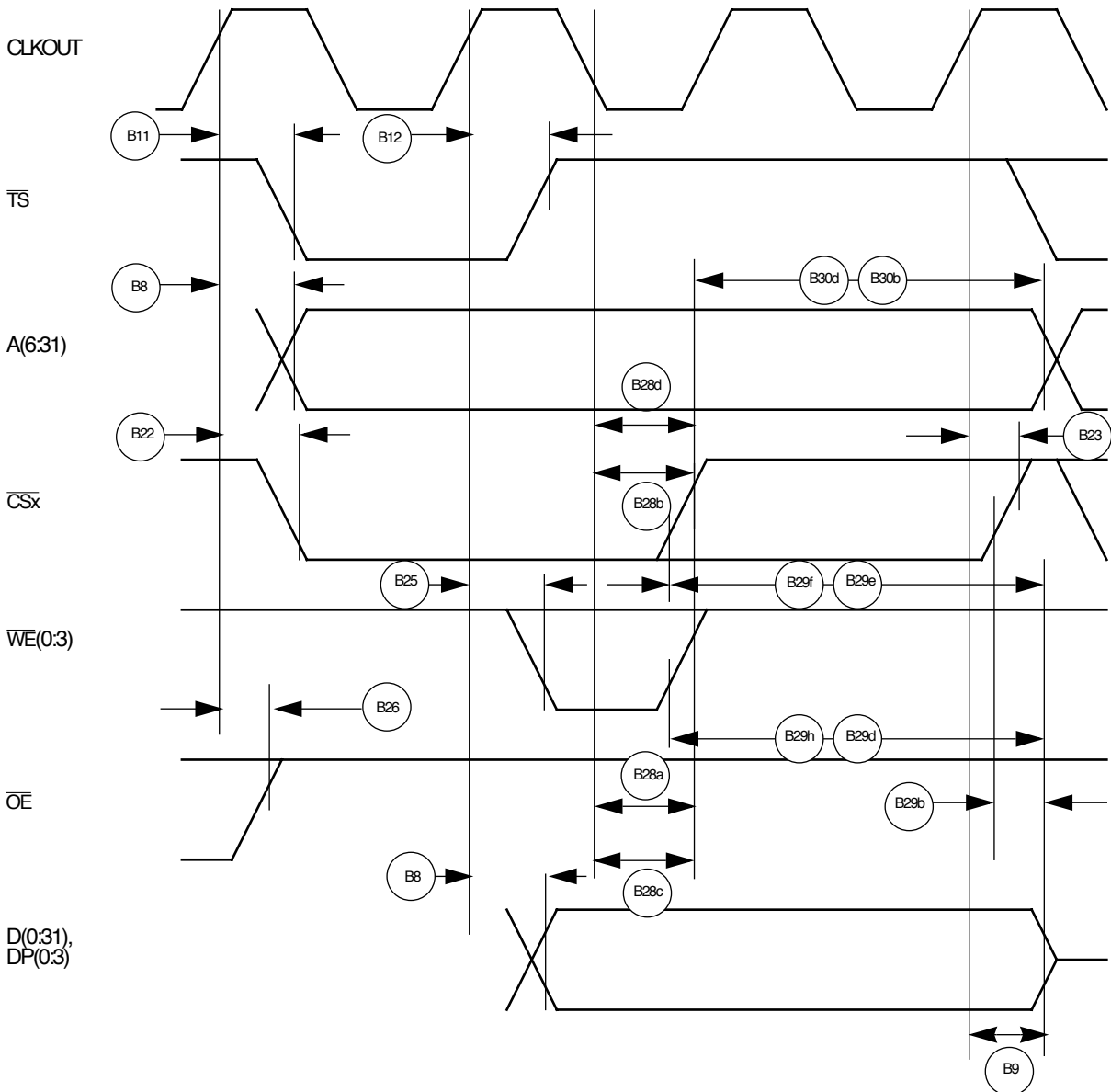

Figure 13. External Bus Write Timing Diagram  
(GPCM Controlled-TRLX = '1', CSNT = '1')

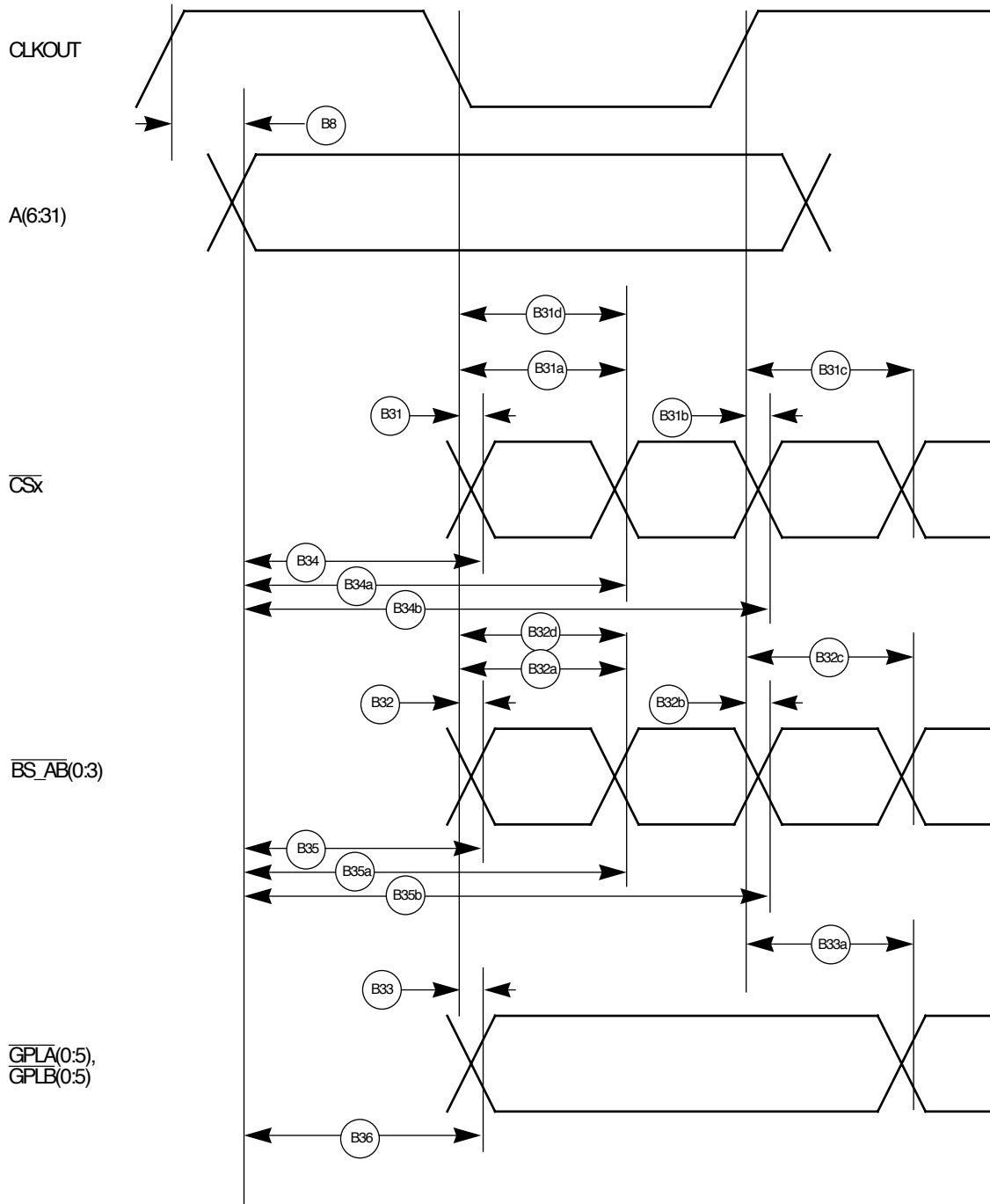

Figure 14. External Bus Timing Diagram (UPM-Controlled Signals)

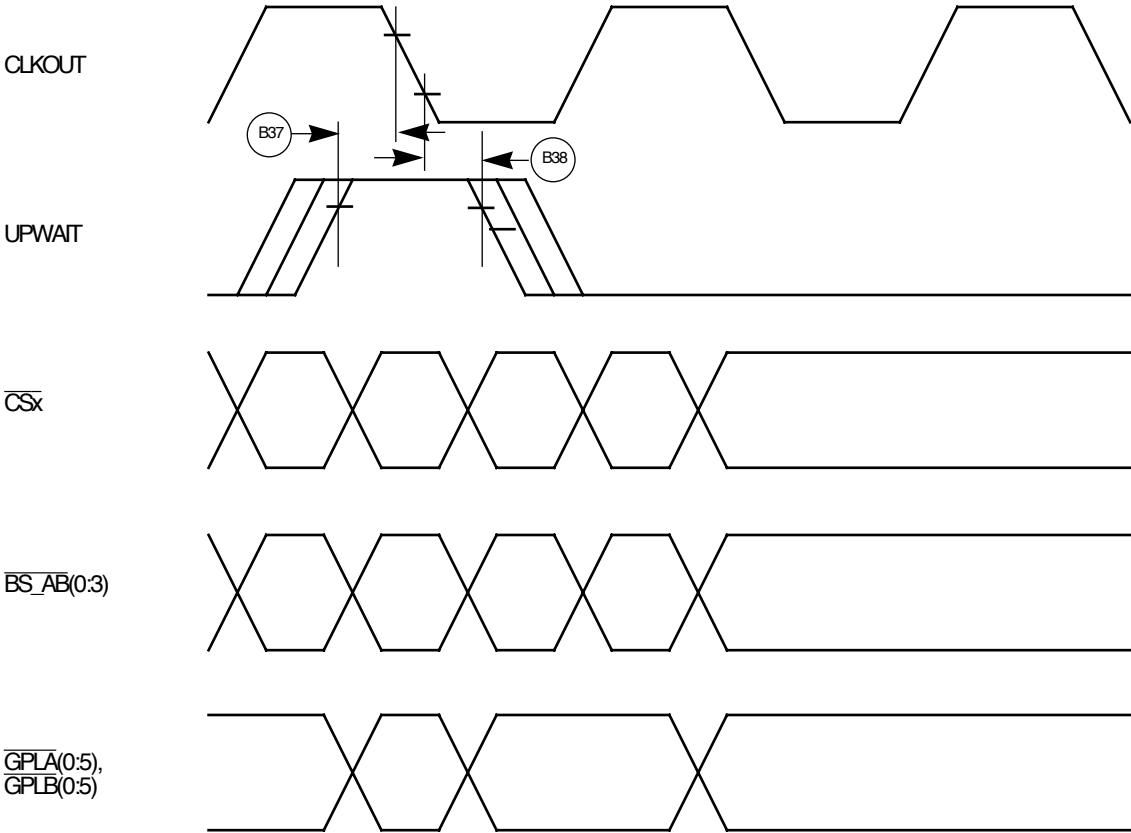
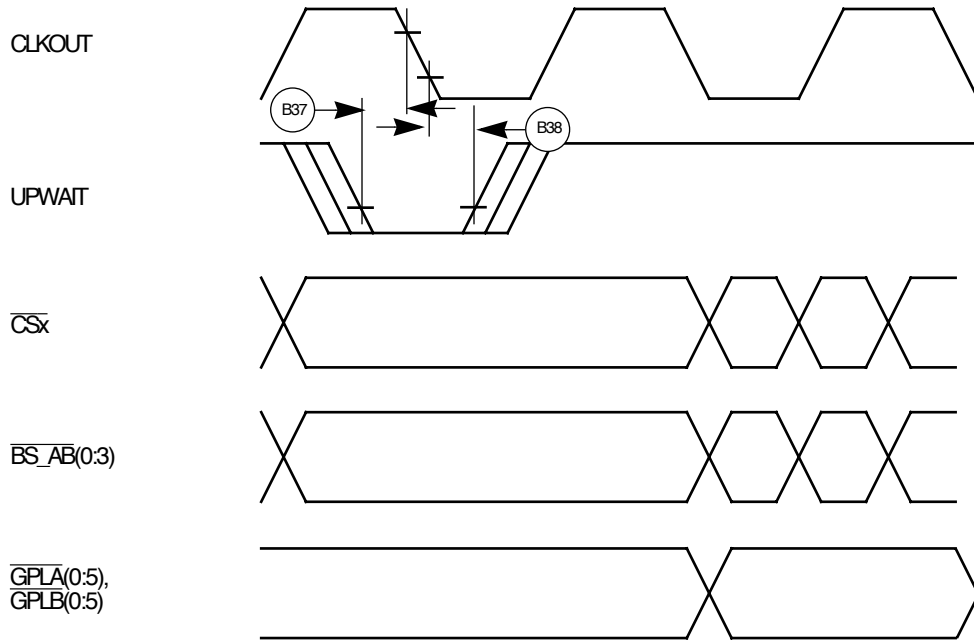
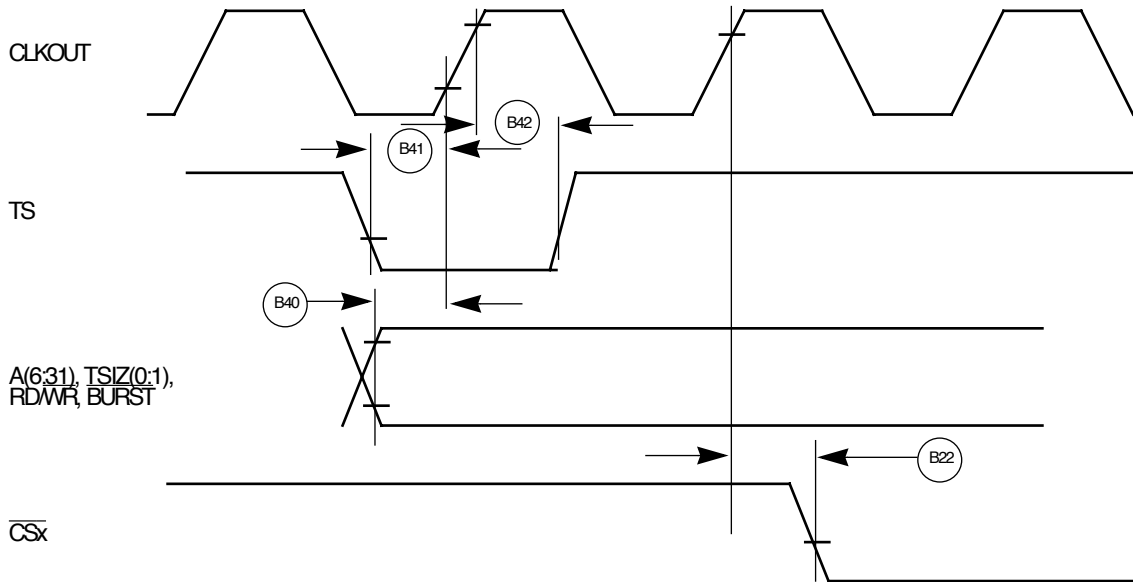

Figure 15. Asynchronous UPWAIT Asserted Detection in UPM Handled Cycles Timing Diagram



**Figure 16. Asynchronous UPWAIT Negated Detection in UPM Handled Cycles Timing Diagram**



**Figure 17. Synchronous External Master Access Timing Diagram (GPCM Handled—ACS = '00')**

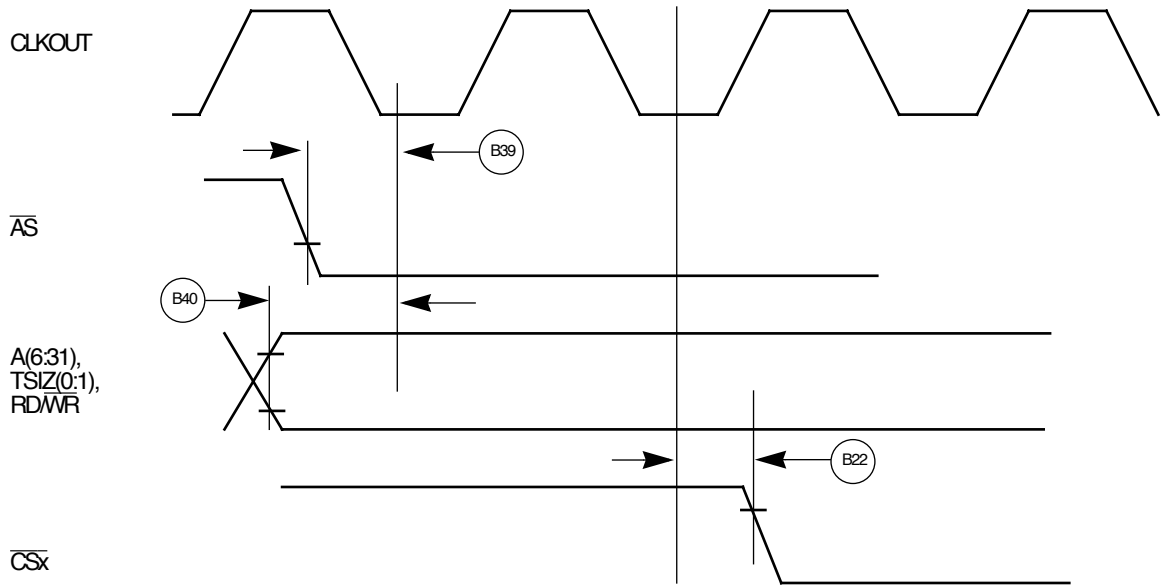

Figure 18. Asynchronous External Master Memory Access Timing Diagram (GPCM Controlled—ACS = '00')

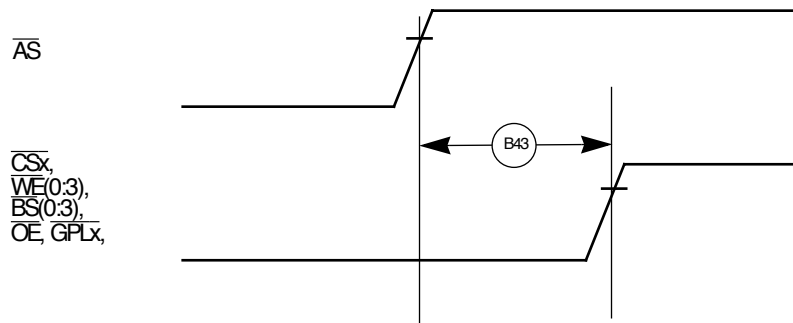

Figure 19. Asynchronous External Master Timing Diagram (Control Signals Negation Time)



Table 2. Interrupt Timing

NUM	CHARACTERISTIC	25MHZ		40MHZ		50MHZ		UNIT
		MIN	MAX	MIN	MAX	MIN	MAX	
I39	$\overline{IRQx}$ valid to CLKOUT rising edge (setup time)	6	—	6/6	—	6/6	—	ns
I40	$\overline{IRQx}$ hold time after CLKOUT	2	—	2/2	—	2/2	—	ns
I41	$\overline{IRQx}$ pulse width low	3	—	3/3	—	3/3	—	ns
I42	$\overline{IRQx}$ pulse width high	3	— </td <td>3/3</td> <td>—</td> <td>3/3</td> <td>—</td> <td>ns</td>	3/3	—	3/3	—	ns
I43	$\overline{IRQx}$ edge to edge time	160	—	80/80	—	80/80	—	ns

NOTES:

1. The timings I39 and I40 describe the testing conditions under which the  $\overline{IRQ}$  lines are tested when defined as level sensitive. The  $\overline{IRQ}$  lines are synchronized internally and do not have to be asserted or negated with reference to the CLKOUT.
2. The timings I41 and I42 are specified to allow the correct function of the  $\overline{IRQ}$  lines detection circuitry, and has no direct relation with the total system interrupt latency that the MPC823 can support.

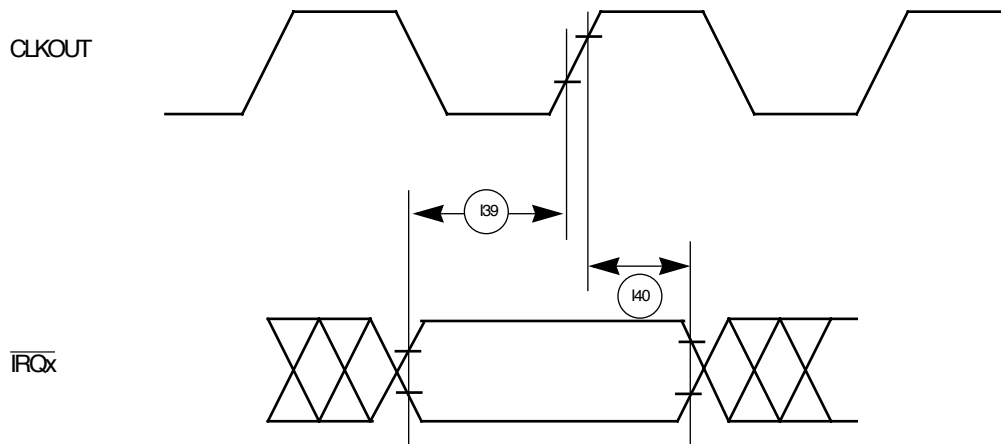
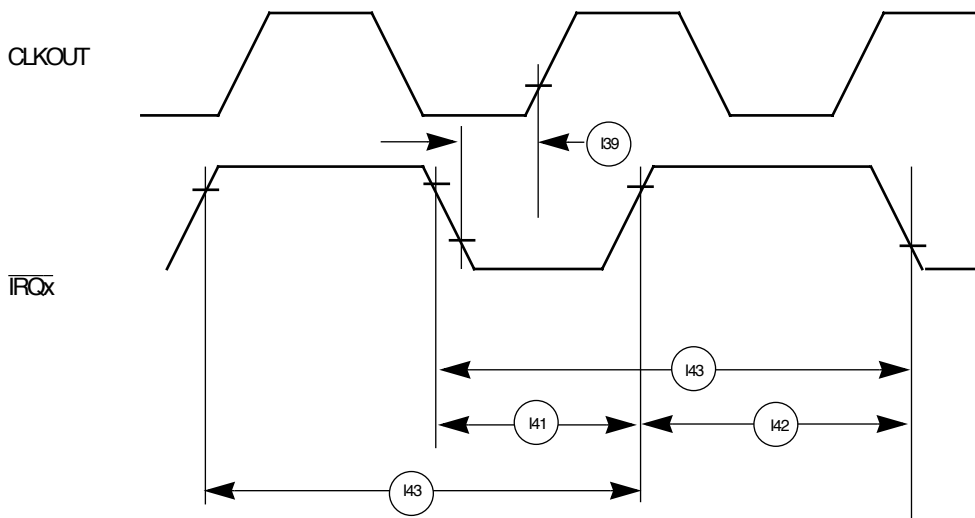

Figure 20. Interrupt Detection Timing Diagram for External Level-Sensitive Lines



**Figure 21. Interrupt Detection Timing Diagram for External Edge-Sensitive Lines**

**Table 3. PCMCIA Timing**

NUM	CHARACTERISTIC	25MHZ		40MHZ		50MHZ		UNIT
		MIN	MAX	MIN	MAX	MIN	MAX	
P44	A(6:31), $\overline{REG}$ valid to PCMCIA strobe asserted	28	—	13	—	13	—	ns
P45	A(6:31), $\overline{REG}$ valid to ALE negation	38	—	18	—	18	—	ns
P46	CLKOUT to $\overline{REG}$ valid	10	19	5	13	5	13	ns
P47	CLKOUT to $\overline{REG}$ invalid	11	—	6	—	6	—	ns
P48	CLKOUT to $\overline{CE1}$ , $\overline{CE2}$ asserted	10	19	5	13	5	13	ns
P49	CLKOUT to $\overline{CE1}$ , $\overline{CE2}$ negated	10	19	5	13	5	13	ns
P50	CLKOUT to $\overline{PCOE}$ , $\overline{IORD}$ , $\overline{PCWE}$ , $\overline{IOWR}$ assert time	—	12	—	11	—	11	ns
P51	CLKOUT to $\overline{PCOE}$ , $\overline{IORD}$ , $\overline{PCWE}$ , $\overline{IOWR}$ negate time	3	12	2	11	2	11	ns
P52	CLKOUT to ALE assert time	10	19	5	13	5	13	ns
P53	CLKOUT to ALE negate time	—	19	—	13	—	13	ns
P54	$\overline{PCWE}$ , $\overline{IOWR}$ negated to D(0:31) invalid	8	—	3	—	3	—	ns
P55	$\overline{WAIT\_B}$ valid to CLKOUT rising edge	8	—	8	—	8	—	ns
P56	CLKOUT rising edge to $\overline{WAIT\_B}$ invalid	2	—	2	—	2	—	ns

**NOTES:**

1. PSST = 1. Otherwise, add PSST times cycle time.
2. PSHT = 0. Otherwise, add PSHT times cycle time.
3. These synchronous timings define when the  $\overline{WAIT\_B}$  signal is detected in order to freeze (or relieve) the PCMCIA current cycle. The  $\overline{WAIT\_B}$  assertion will be effective only if it is detected two cycles before the PSL timer expiration.

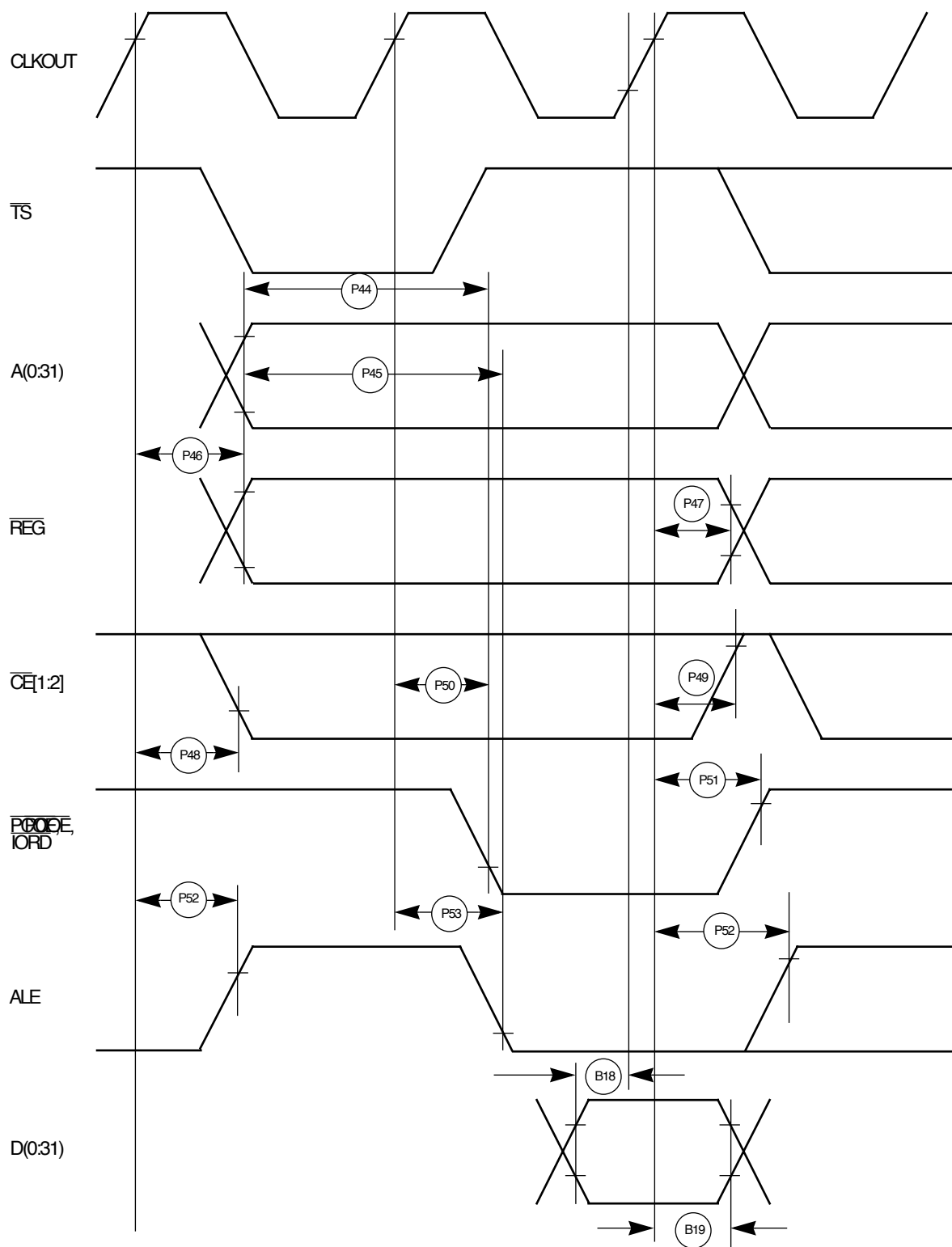

Figure 22. PCMCIA Access Cycles Timing Diagram (External Bus Read)

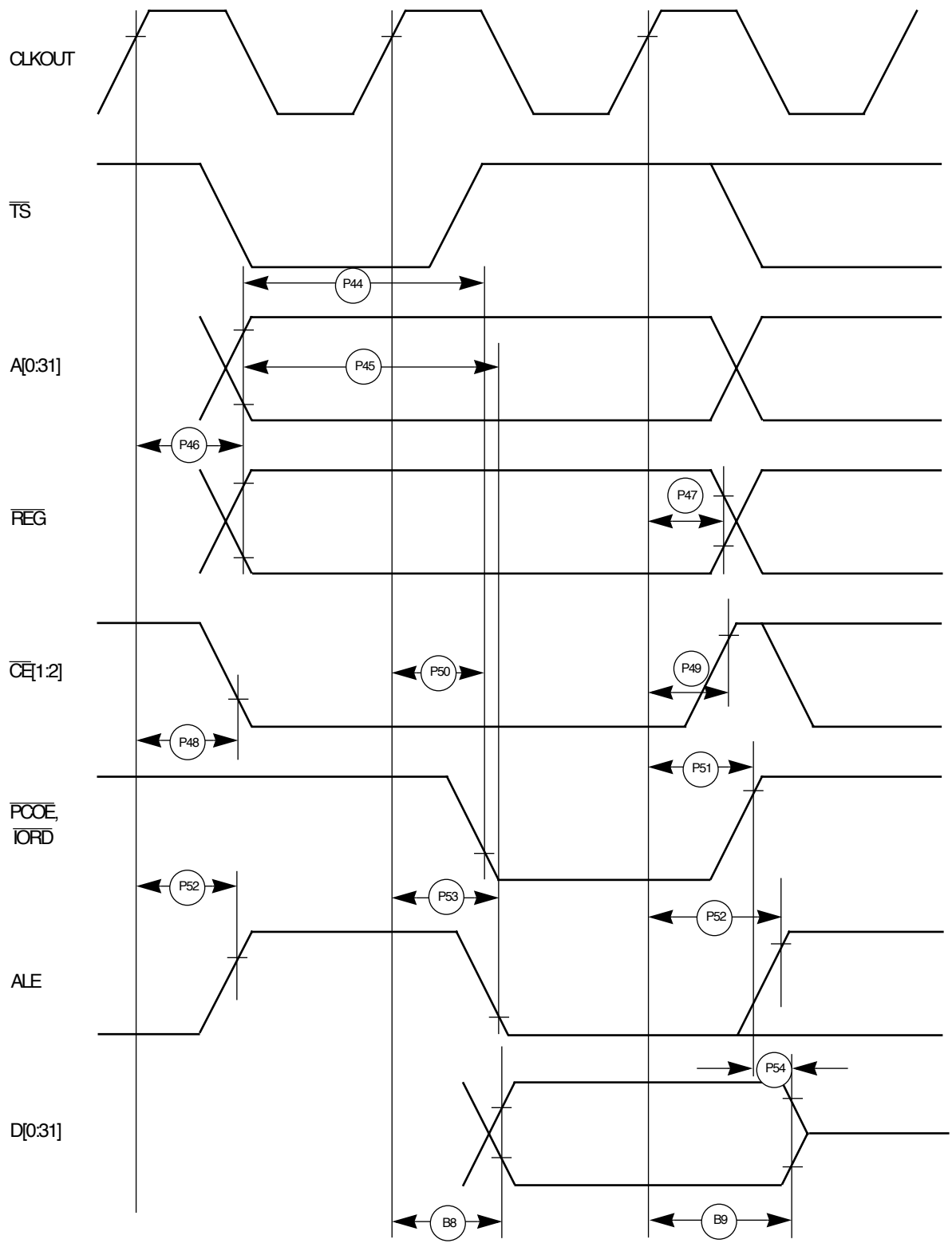
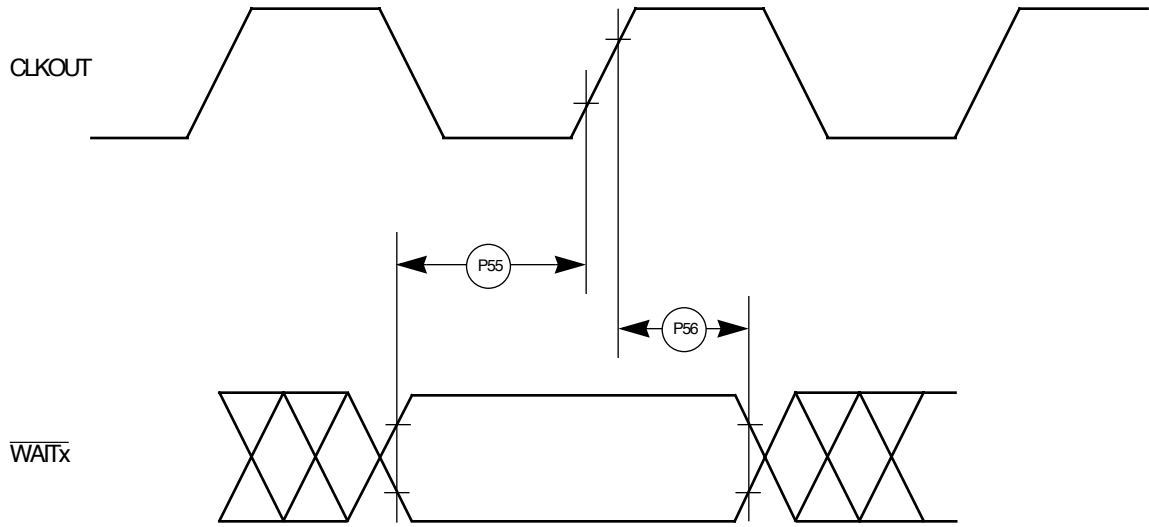
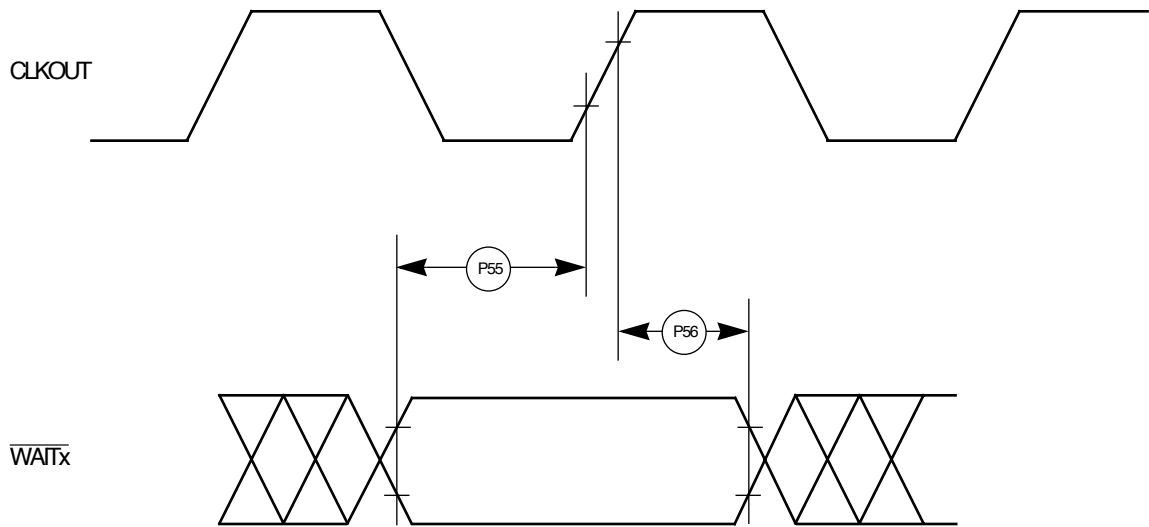

Figure 23. PCMCIA Access Cycles Timing Diagram (External Bus Write)



**Figure 24. PCMCIA Wait Signals Detection Timing Diagram**

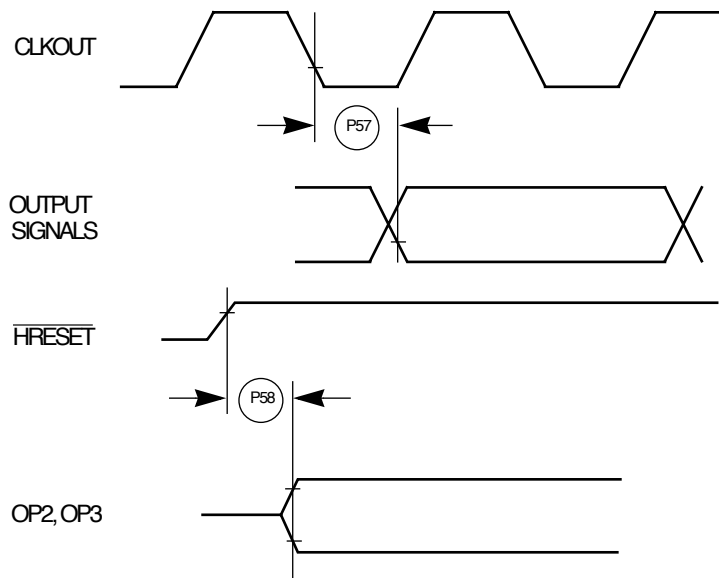

**Figure 25. PCMCIA Wait Signals Detection Timing Diagram**

**Table 4. PCMCIA Port Timing**

NUM	CHARACTERISTIC	25MHZ		40MHZ		50MHZ		UNIT
		MIN	MAX	MIN	MAX	MIN	MAX	
P57	CLKOUT to OPx Valid	—	25	—	19	—	19	ns
P58	HRESET negated to OPx drive	30	—	18	—	18	—	ns
P59	IP_Bx valid to CLKOUT Rising Edge	6	—	5	—	5	—	ns
P60	CLKOUT Rising Edge to IP_Bx invalid	2	—	1	—	1	—	ns

NOTE: \*OP2 and OP3 only.



**Figure 26. PCMCIA Output Port Timing Diagram**

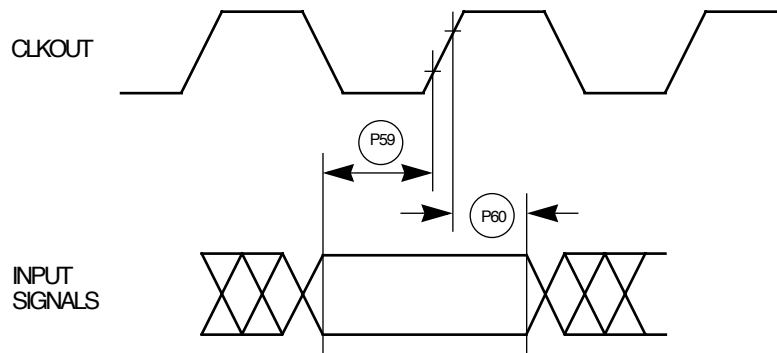

**Figure 27. PCMCIA Input Port Timing Diagram**

Table 5. Debug Port Timing

NUM	CHARACTERISTIC	25MHZ		40MHZ		50MHZ		UNIT
		MIN	MAX	MIN	MAX	MIN	MAX	
D61	DSCK cycle time	120	—	60	—	60	—	ns
D62	DSCK clock pulse width	50	—	25	—	25	—	ns
D63	DSCK rise and fall times	0	3	0	3	0	3	ns
D64	DSDI input data setup time	8	—	8	—	8	—	ns
D65	DSDI data hold time	5	—	5	—	5	—	ns
D66	DSCK low to DSDO data valid	0	15	0	15	0	15	ns
D67	DSCK low to DSDO invalid	0	2	0	2	0	2	ns

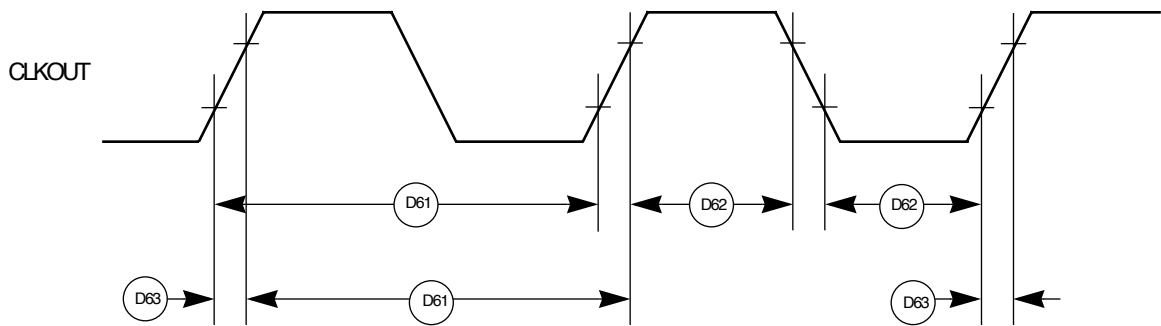

Figure 28. Debug Port Clock Input Timing Diagram



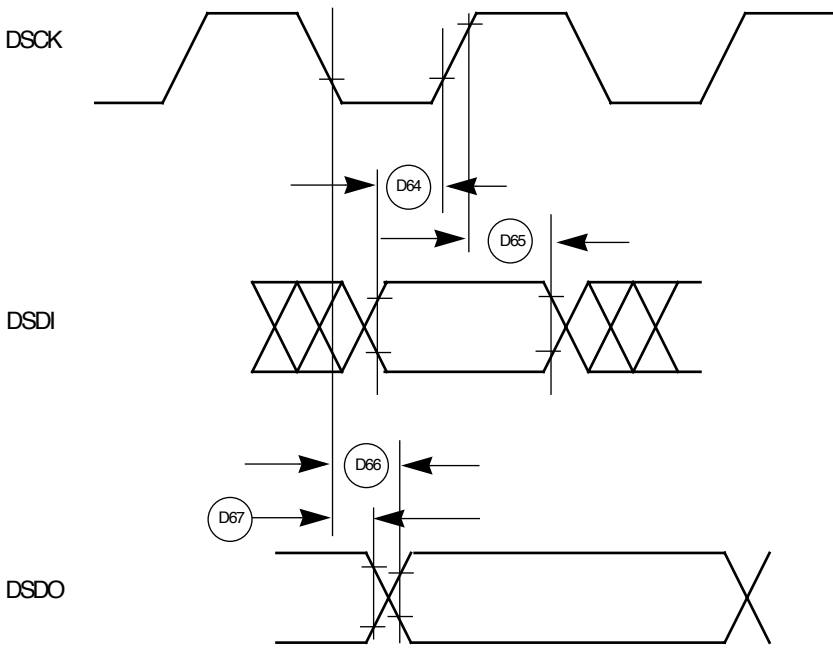

Figure 29. Debug Port Timing Diagram

**Table 6. Reset Timing**

NUM	CHARACTERISTIC	25MHZ		40MHZ		50MHZ		UNIT
		MIN	MAX	MIN	MAX	MIN	MAX	
R68	CLKOUT to $\overline{\text{HRESET}}$ high impedance	—	20	—	20	—	20	ns
R69	CLKOUT to $\overline{\text{SRESET}}$ high impedance	—	20	—	20	—	20	ns
R70	$\overline{\text{RSTCONF}}$ pulse width	680	—	425	—	340	—	ns
R71	N/A							
R72	Configuration data to $\overline{\text{HRESET}}$ rising edge setup time	650	—	425	—	350	—	ns
R73	Configuration data to $\overline{\text{RSTCONF}}$ rising edge setup time	650	—	425	—	350	—	ns
R74	Configuration data hold time after $\overline{\text{RSTCONF}}$ negation	0	—	0	—	0	—	ns
R75	Configuration data hold time after $\overline{\text{HRESET}}$ negation	0	—	0	—	0	—	ns
R76	$\overline{\text{HRESET}}$ and $\overline{\text{RSTCONF}}$ asserted to data out drive	—	25	—	25	—	25	ns
R77	$\overline{\text{RSTCONF}}$ negated to data out high impedance	—	25	—	25	—	25	ns
R78	CLKOUT of last rising edge before chip three-states $\overline{\text{HRESET}}$ to data out high impedance	—	25	—	25	—	25	ns
R79	DSDI and DSCK setup	120	—	75	—	60	—	ns
R80	DSDI and DSCK hold time	0	—	0	—	0	—	ns
R81	$\overline{\text{SRESET}}$ negated to CLKOUT rising edge for DSDI and DSCK sample	320	—	200	—	160	—	ns

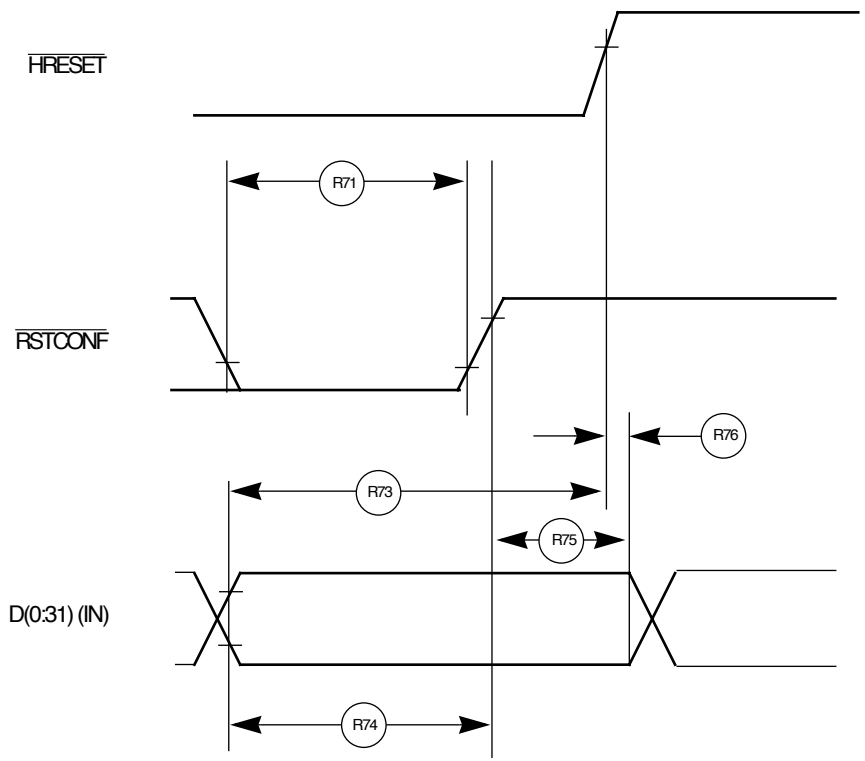

Figure 30. Reset Timing Diagram (Configuration from Data Bus)

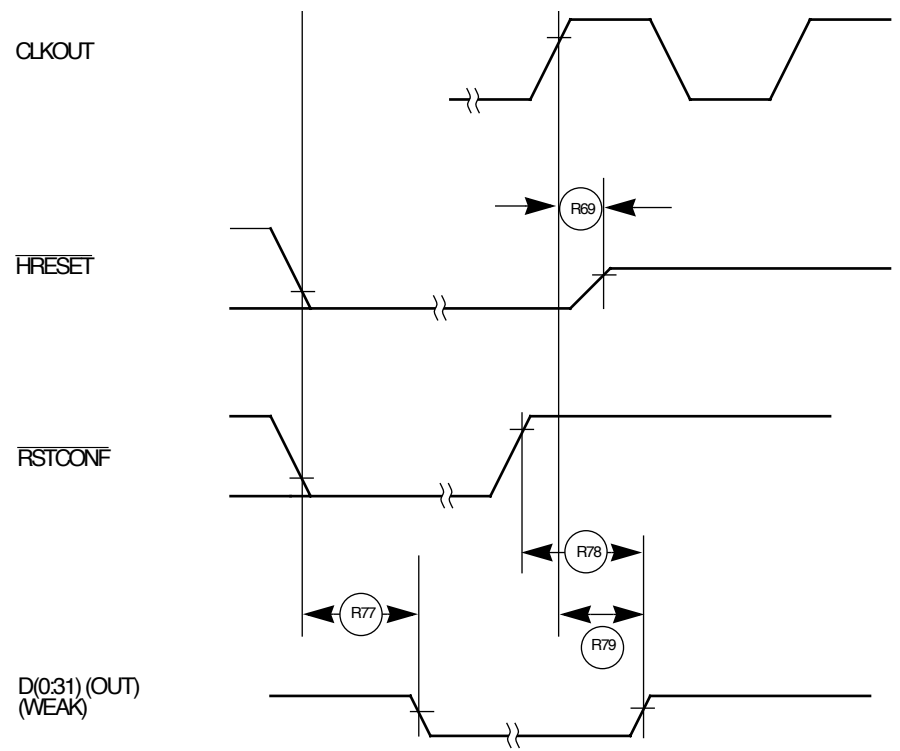

Figure 31. Reset Timing Diagram—MPC823 Data Bus Weak Drive During Configuration

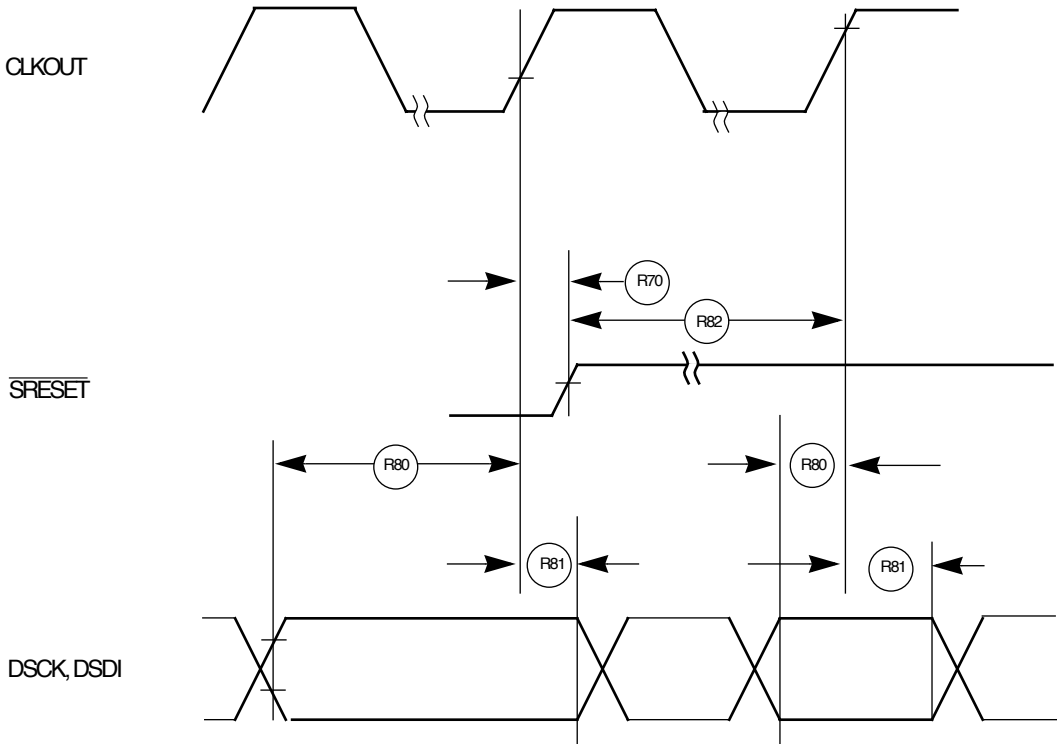

Figure 32. Reset Timing Diagram–Debug Port Configuration

Table 7. JTAG Timing

NUM	CHARACTERISTIC	25MHZ		40MHZ		50MHZ		UNIT
		MIN	MAX	MIN	MAX	MIN	MAX	
J82	TCK cycle time	100	—	100	—	100	—	ns
J83	TCK clock pulse width measured at 1.5V	40	—	40	—	40	—	ns
J84	TCK rise and fall times	0	10	0	10	0	10	ns
J85	TMS, TDI data setup time	5	—	5	—	5	—	ns
J86	TMS, TDI data hold time	25	—	25	—	25	—	ns
J87	TCK low to TDO data valid	—	27	—	27	—	27	ns
J88	TCK low to TDO data invalid	0	—	0	—	0	—	ns
J89	TCK low to TDO high impedance	—	20	—	20	—	20	ns
J90	$\overline{\text{TRST}}$ assert time	100	—	100	—	100	—	ns
J91	$\overline{\text{TRST}}$ setup time to TCK low	40	—	40	—	40	—	ns
J92	TCK falling edge to output valid	—	50	—	50	—	50	ns
J93	TCK falling edge to output valid out of high impedance	—	50	—	50	—	50	ns
J94	TCK falling edge to output high impedance	—	50	—	50	—	50	ns
J95	Boundary scan input valid to TCK rising edge	50	—	50	—	50	—	ns
J96	TCK rising edge to boundary scan input invalid	50	—	50	—	50	—	ns

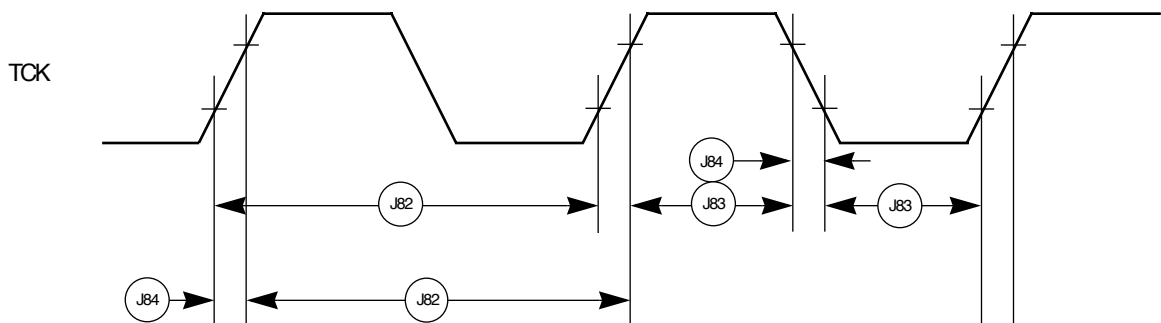

Figure 33. JTAG Test Clock Input Timing Diagram

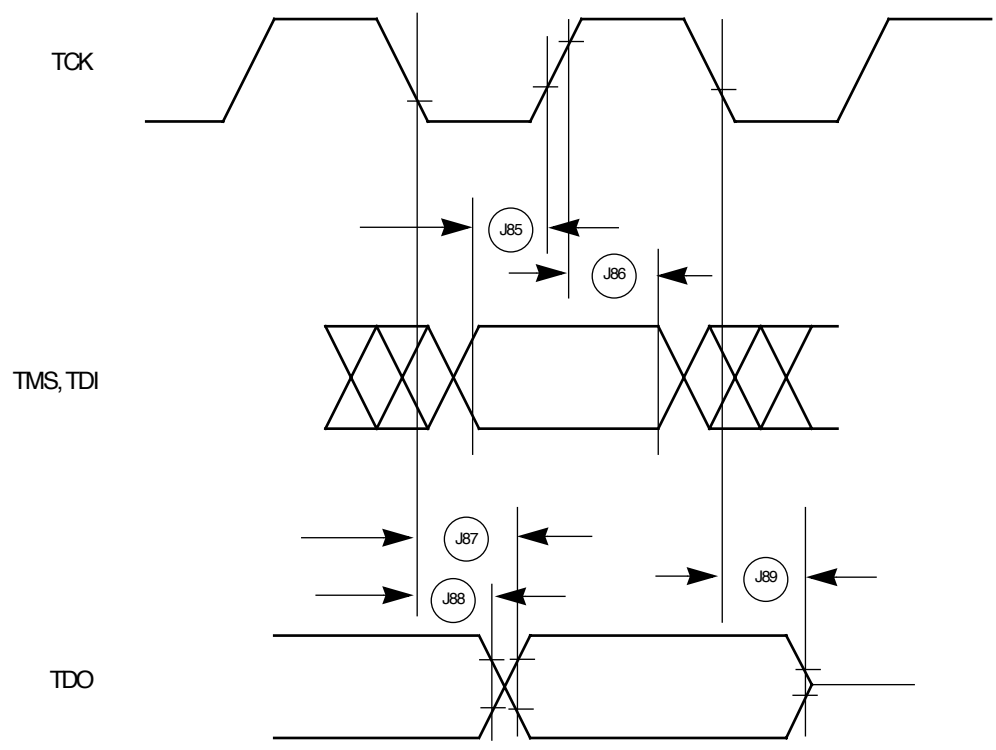

Figure 34. JTAG-Test Access Port Timing Diagram

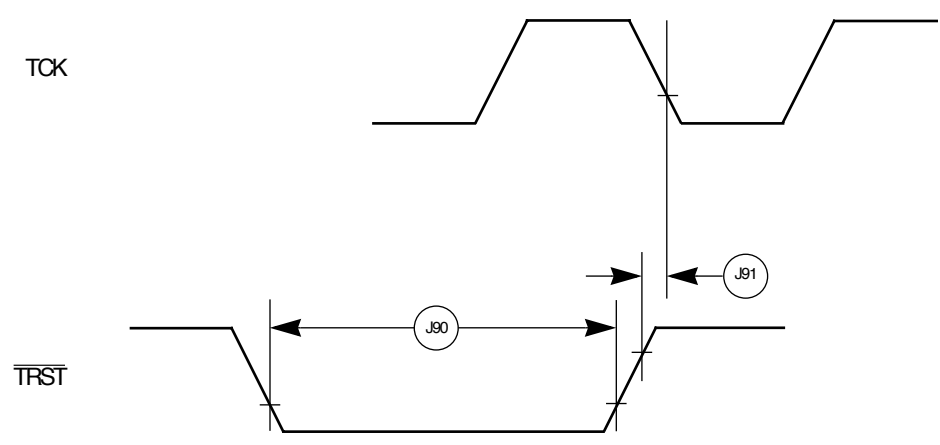

Figure 35. JTAG-TRST Timing Diagram

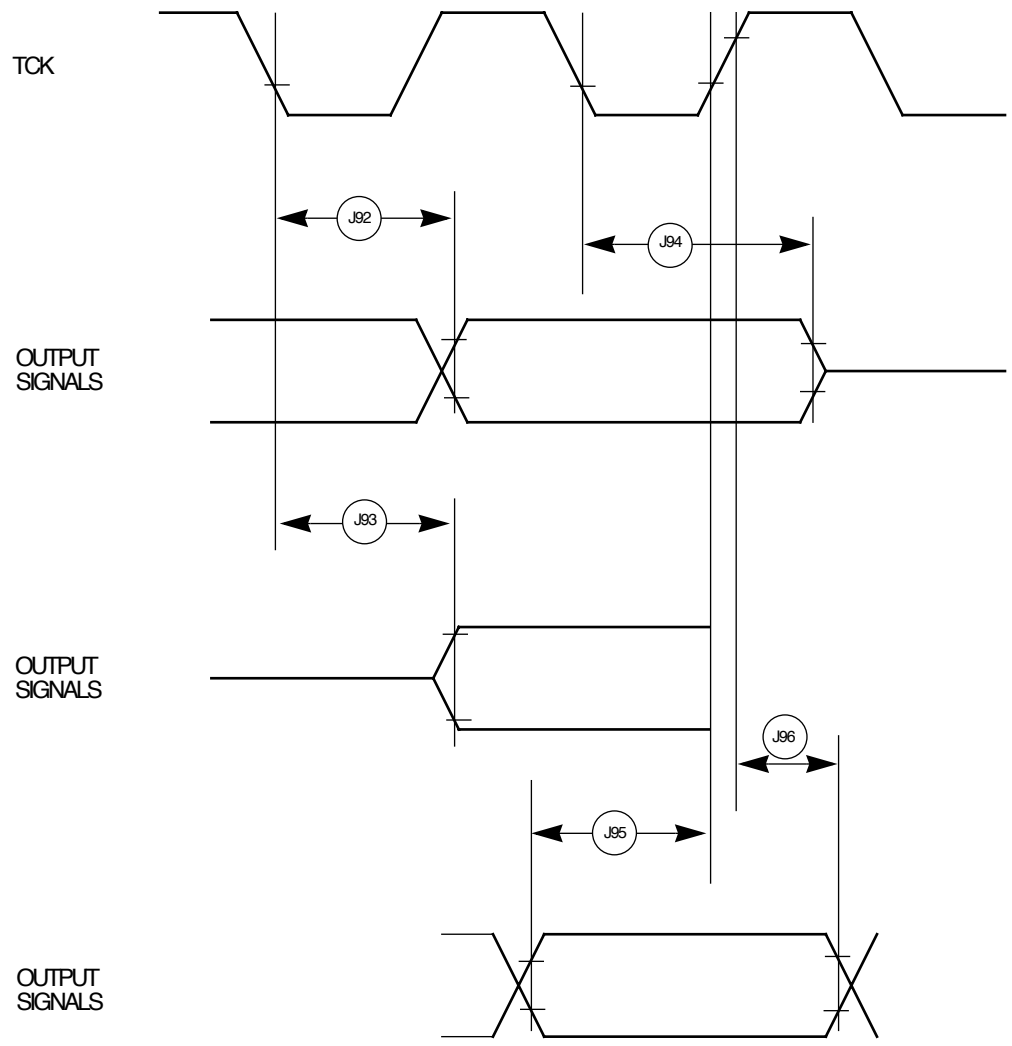
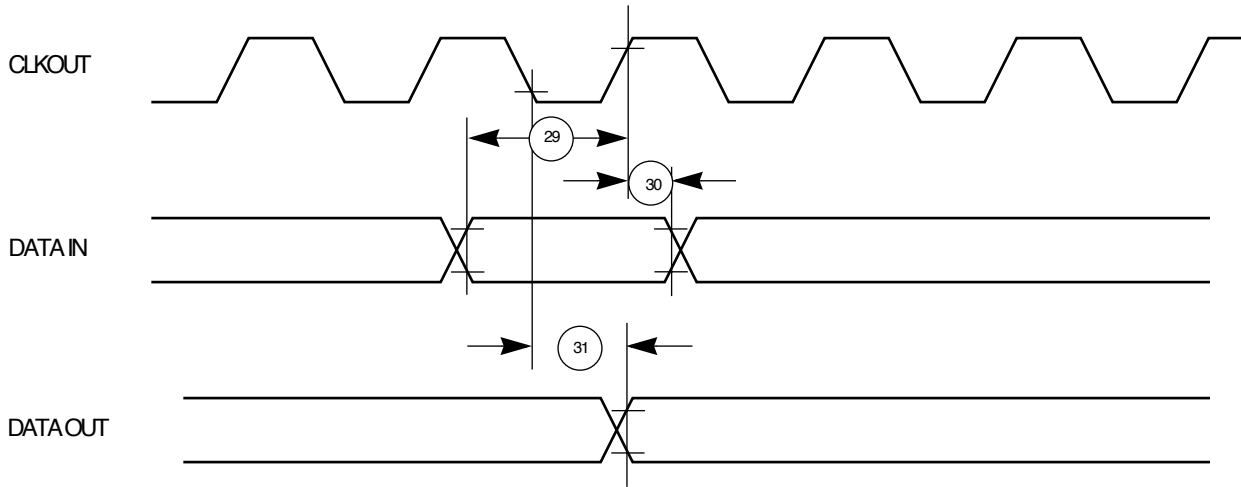

Figure 36. Boundary Scan (JTAG) Timing Diagram

**COMMUNICATION ELECTRICAL CHARACTERISTICS**

**Table 8. Parallel Input/Output Port Timing**

NUM	CHARACTERISTIC	25MHZ		40MHZ		50MHZ		UNIT
		MIN	MAX	MIN	MAX	MIN	MAX	
29	Data-in setup time to clock high	20	—	15	—	15	—	ns
30	Data-in hold time from clock high	10	—	7.5	—	7.5	—	ns
31	Clock high to data-out valid (CPU writes data, control, or direction)	—	25	—	25	—	25	ns



**Figure 37. Parallel Input/Output Data-In/Data-Out Timing Diagram**



Table 9. IDMA Timing

NUM	CHARACTERISTIC	25MHZ		40MHZ		50MHZ		UNIT
		MIN	MAX	MIN	MAX	MIN	MAX	
40	$\overline{DREQ}$ setup time to clock high	12	—	7	—	7	—	nsec
41	$\overline{DREQ}$ hold time from clock high	5	—	3	—	3	—	nsec
42	$\overline{SDACK}$ assertion delay from clock high	—	20	—	12	—	12	nsec
43	$\overline{SDACK}$ negation delay from clock low	—	20	—	12	—	12	nsec
44	$\overline{SDACK}$ negation delay from $\overline{TA}$ low	—	25	—	20	—	20	nsec
45	$\overline{SDACK}$ negation delay from clock high	—	20	—	15	—	15	nsec
46	$\overline{TA}$ assertion to falling edge of the clock setup time	12	—	7	—	7	—	nsec

NOTE: Applies to external  $\overline{TA}$ .

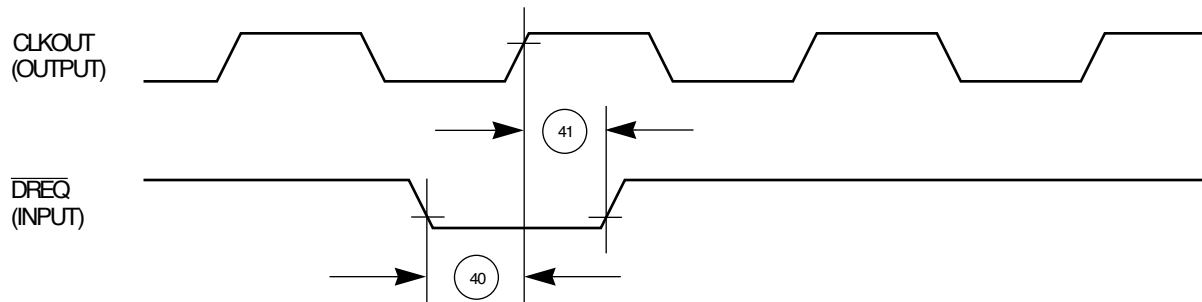

Figure 38. IDMA External Requests Timing Diagram

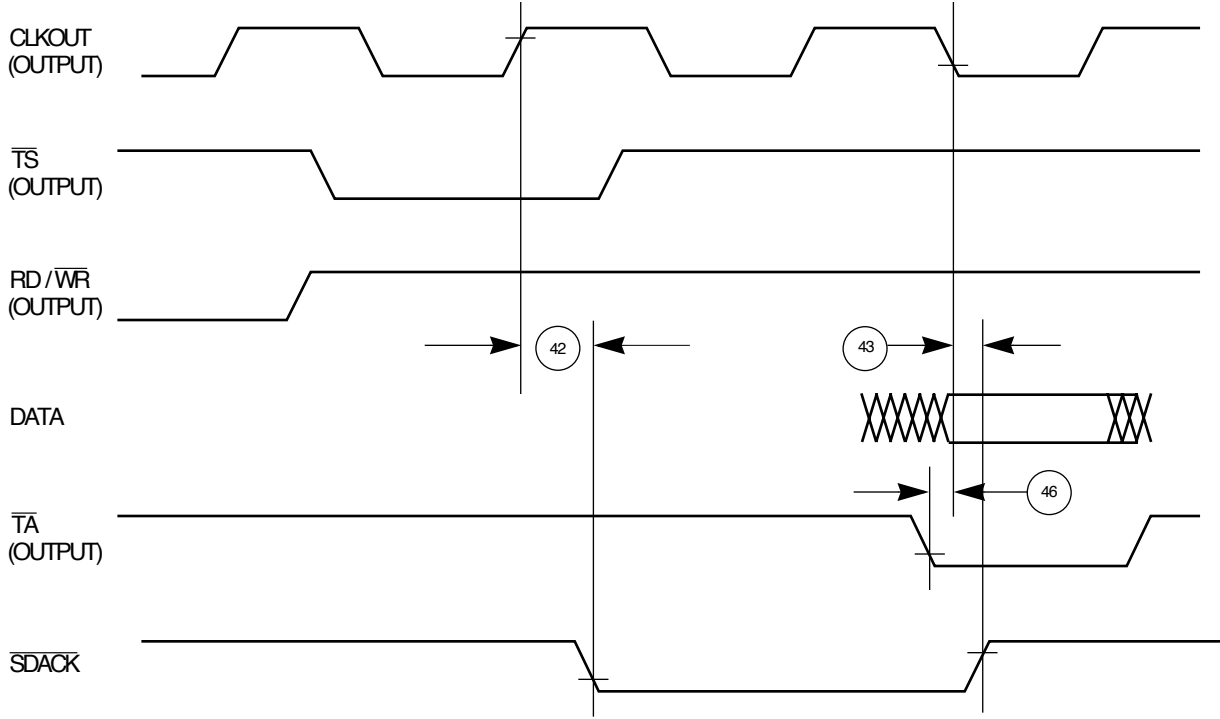

Figure 39.  $\overline{SDACK}$  Timing Diagram—Peripheral Write,  $\overline{TA}$  Sampled Low at the Falling Edge of the Clock

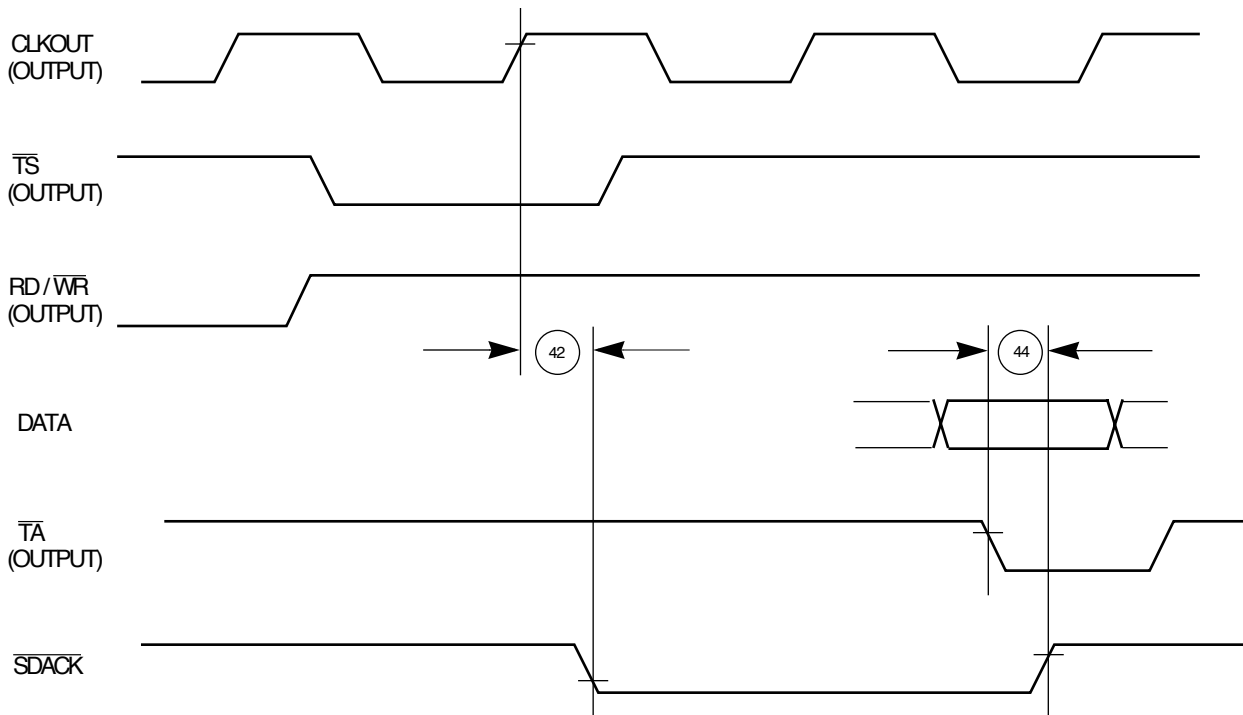

Figure 40.  $\overline{SDACK}$  Timing Diagram—Peripheral Write,  $\overline{TA}$  Sampled High at the Falling Edge of the Clock

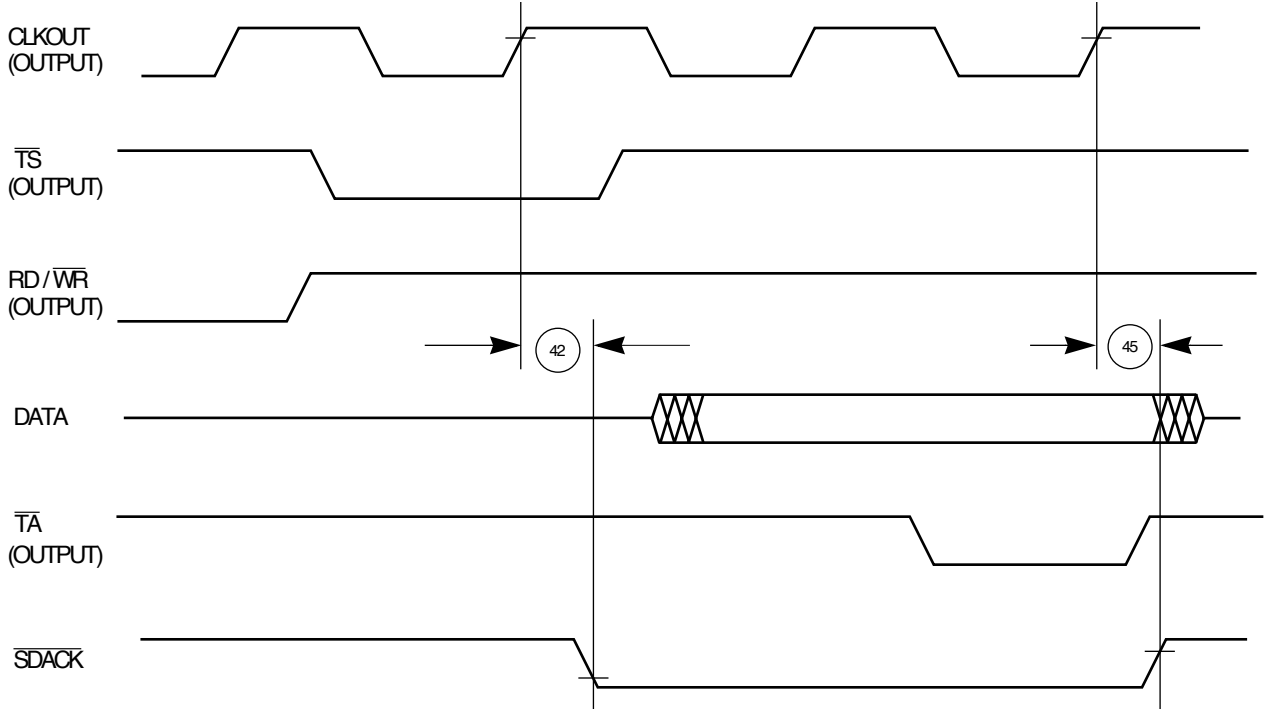
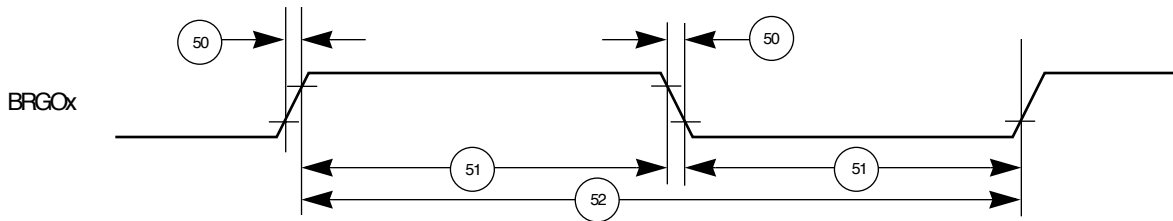

Figure 41.  $\overline{\text{SDACK}}$  Timing Diagram—Peripheral Read

**Table 10. Baud Rate Generator Timing**

NUM	CHARACTERISTIC	25MHZ		40MHZ		50MHZ		UNIT
		MIN	MAX	MIN	MAX	MIN	MAX	
50	BRGO rise and fall times	—	10	—	10	—	10	ns
51	BRGO duty cycle	40	60	40	60	40	60	%
52	BRGO cycle	40	—	40	—	40	—	ns



**Figure 42. Baud Rate Generator Timing Diagram**

**Table 11. General-Purpose Timers Timing**

NUM	CHARACTERISTIC	25MHZ		40MHZ		50MHZ		UNIT
		MIN	MAX	MIN	MAX	MIN	MAX	
61	TIN/ $\overline{\text{TGATE}}$ rise and fall times	12	10	7	10	7	10	ns
62	TIN/ $\overline{\text{TGATE}}$ low time	5	1	3	1	3	1	clk
63	TIN/ $\overline{\text{TGATE}}$ high time	—	20	—	12	—	12	clk
64	TIN/ $\overline{\text{TGATE}}$ cycle time	—	20	—	12	—	12	clk
65	CLKO low to $\overline{\text{TOU}}$ valid	—	25	—	20	—	20	ns

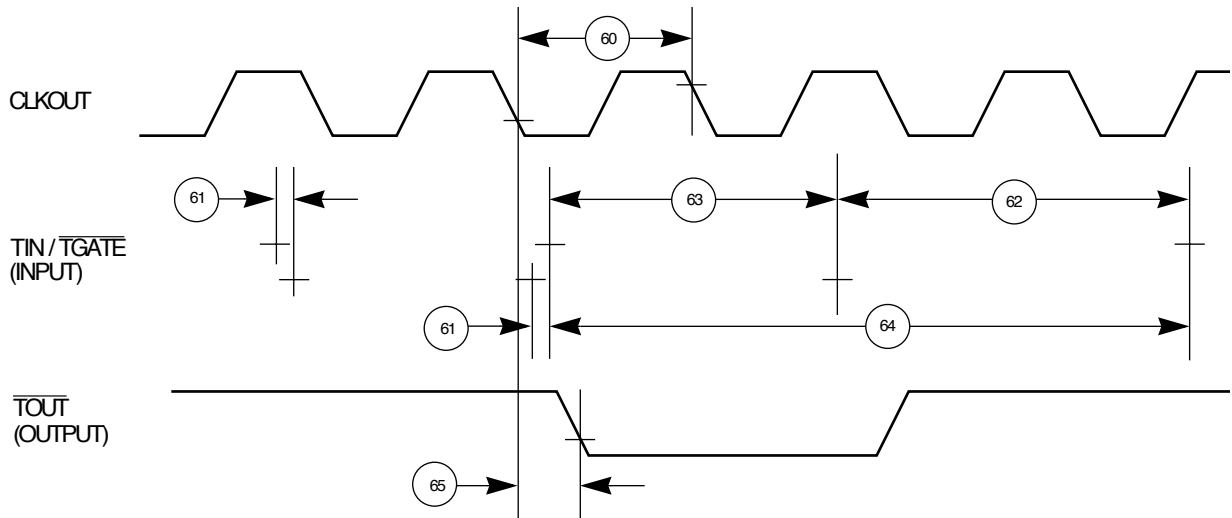

**Figure 43. General-Purpose Timers Timing Diagram**

**Table 12. Serial Interface Timing**

NUM	CHARACTERISTIC	25MHZ		40MHZ		50MHZ		UNIT
		MIN	MAX	MIN	MAX	MIN	MAX	
70	L1RCLK and L1TCLK frequency (DSC=0) <sup>1,3</sup>	—	10	—	10	—	10	MHz
71	L1RCLK and L1TCLK width low (DSC=0) <sup>3</sup>	P+10	—	P+10	—	P+10	—	ns
71a	L1RCLK and L1TCLK width high (DSC=0) <sup>2</sup>	P+10	—	P+10	—	P+10	—	ns
72	L1TXD, L1ST(1–8), L1RQ, L1CLKO rise and fall times	—	15	—	15	—	15	ns
73	L1RSYNC, L1TSYNC valid to L1CLK edge (SYNC setup time)	20	—	20	—	20	—	ns
74	L1CLK edge to L1RSYNC and L1TSYNC invalid (SYNC hold time)	35	—	35	—	35	—	ns
75	L1RSYNC and L1TSYNC rise and fall times	—	15	—	15	—	15	ns
76	L1RXD valid to L1CLK edge (L1RXD setup time)	42	—	42	—	42	—	ns
77	L1CLK edge to L1RXD invalid (L1RXD hold time)	35	—	35	—	35	—	ns
78	L1CLK edge to L1ST(1–8) valid	10	45	10	45	10	45	ns
78a	L1SYNC valid to L1ST(1–8) valid <sup>4</sup>	10	45	10	45	10	45	ns
79	L1CLK edge to L1ST(1–8) invalid	10	45	10	45	10	45	ns
80	L1CLK edge to L1TXD valid	10	65	10	65	10	65	ns
80a	L1TSYNC valid to L1TXD valid <sup>4</sup>	10	65	10	65	10	65	ns
81	L1CLK edge to L1TXD high impedance	0	42	0	42	0	42	ns
82	L1RCLK and L1TCLK frequency (DSC=1)	—	12.5	—	16	—	16	MHz
83	L1RCLK and L1TCLK width low (DSC=1)	P+10	—	P+10	—	P+10	—	ns
83a	L1RCLK and L1TCLK width high (DSC=1) <sup>2</sup>	P+10	—	P+10	—	P+10	—	ns
84	L1CLK edge to L1CLKO valid (DSC=1)	—	30	—	30	—	30	ns
85	L1RQ valid before falling edge of L1TSYNC <sup>3</sup>	1	—	1	—	1	—	L1TCLK
86	L1GR setup time <sup>3</sup>	42	—	42	—	42	—	ns
87	L1GR hold time <sup>3</sup>	42	—	42	—	42	—	ns
88	L1CLK edge to L1SYNC valid (FSD = 00, CNT = 0000, BYT = 0, DSC=0)	—	0	—	0	—	0	ns

**NOTES:**

1. The ratio SyncCLK/L1RCLK must be greater than 2.5/1.
2. Where P=1/CLKO1. For a 25MHz CLKO1 rate, P=40ns.
3. These electrical specifications are only valid for IDL mode.
4. The strobes and TXD2 on the first bit of the frame becomes valid after L1CLK edge or L1SYNC, whichever is later.

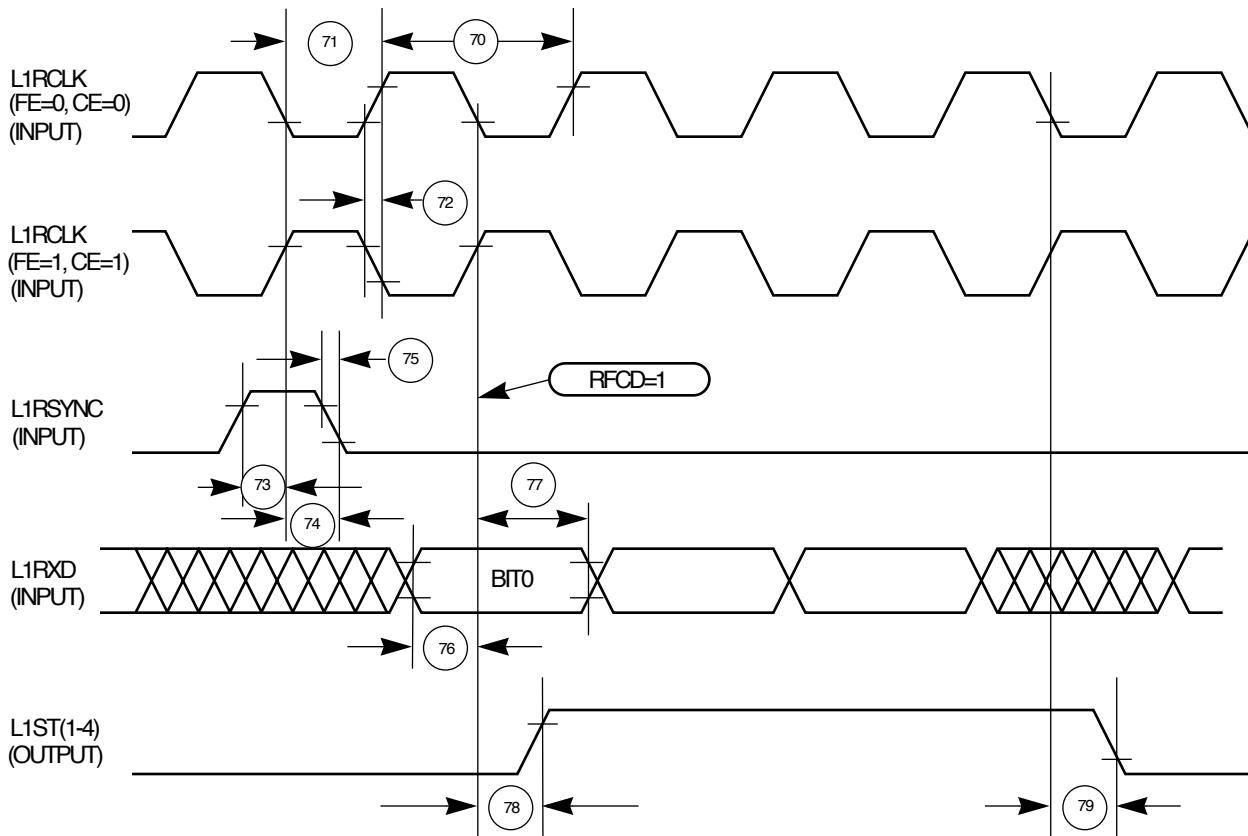

Figure 44. Serial Interface Receive Timing Diagram With Normal Clocking (DSC = 0)



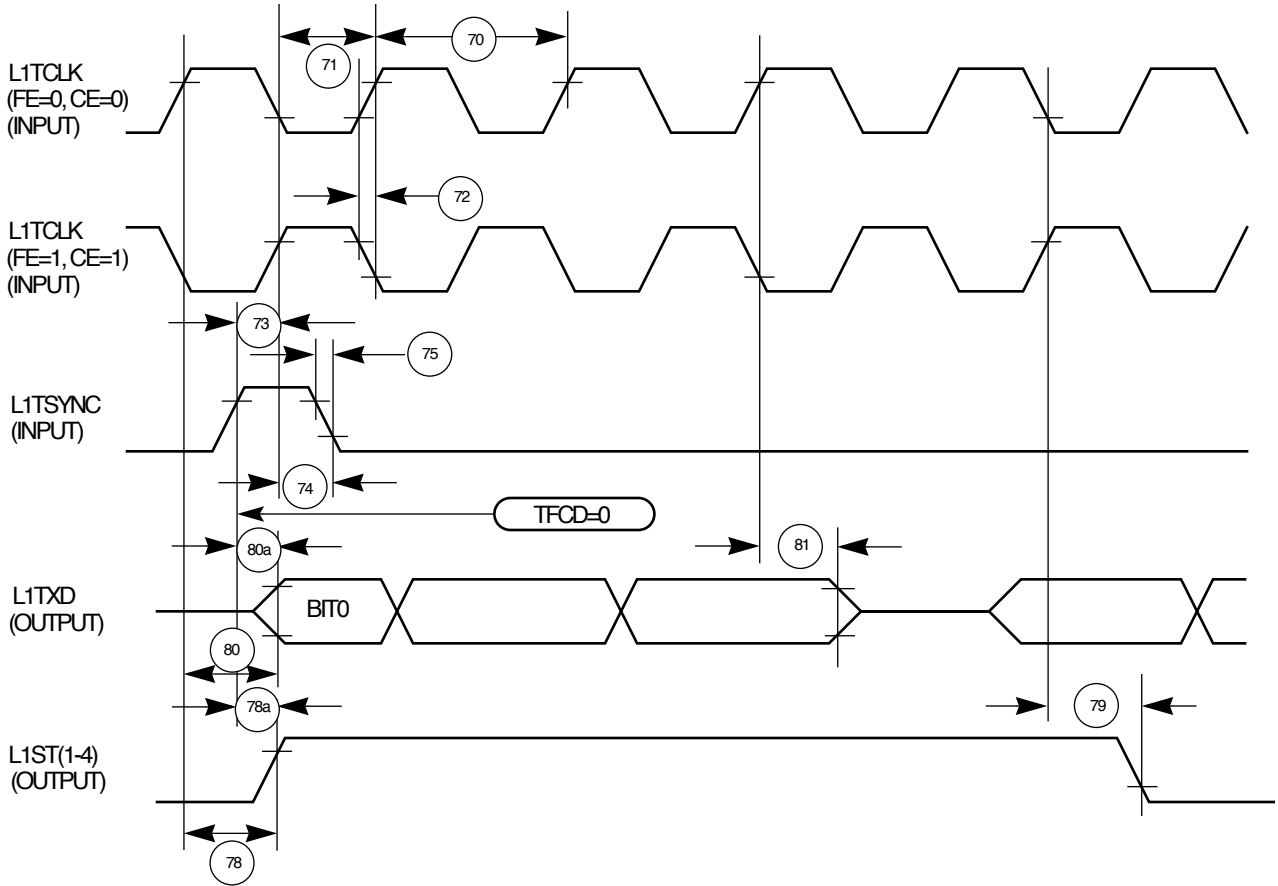

Figure 45. Serial Interface Transmit Timing Diagram

**Table 13. Serial Communication Controller in NMSI External Timing**

NUM	CHARACTERISTIC	25MHZ		40MHZ		50MHZ		UNIT
		MIN	MAX	MIN	MAX	MIN	MAX	
100	RCLK1 and TCLK1 width high <sup>1</sup>	CLKOUT F	—	CLKOUT F	—	CLKOUT F	—	MHz
101	RCLK1 and TCLK1 width low	CLKOUT +5ns	—	CLKOUT +5ns	—	CLKOUT +5ns	—	ns
102	RCLK1 and TCLK1 rise and fall times	—	15	—	15	—	15	ns
103	TXD2 active delay (from TCLK1 falling edge)	0	50	0	50	0	50	ns
104	$\overline{RTS1}$ active/inactive delay (from TCLK1 falling edge)	0	50	0	50	0	50	ns
105	$\overline{CTS1}$ setup time to TCLK1 rising edge	5	—	5	—	5	—	ns
106	RXD2 setup time to RCLK1 rising edge	5	—	5	—	5	—	ns
107	RXD2 hold time from RCLK1 rising edge <sup>2</sup>	5	—	5	—	5	—	ns
108	$\overline{CD1}$ setup time to RCLK1 rising edge	5	—	5	—	5	—	ns

**NOTES:**

1. The ratio SyncCLK/RCLK1 and SyncCLK/TCLK1 must be greater than or equal to 2.25/1.
2. Applies to  $\overline{CD}$  and  $\overline{CTS}$  hold time when they are used as external sync signals.

Table 14. Serial Communication Controller in NMSI Internal Timing

NUM	CHARACTERISTIC	25MHZ		40MHZ		50MHZ		UNIT
		MIN	MAX	MIN	MAX	MIN	MAX	
100	RCLK1 and TCLK1 frequency <sup>1</sup>	0	8.3	0	13	0	16	MHz
102	RCLK1 and TCLK1 rise and all times	—	—	—	—	—	—	ns
103	TXD2 active delay (from TCLK1 falling edge)	0	30	0	30	0	30	ns
104	$\overline{RTS1}$ active/inactive delay (from TCLK1 falling edge)	0	30	0	30	0	30	ns
105	$\overline{CTS1}$ setup time to TCLK1 rising edge	40	—	40	—	40	—	ns
106	RXD2 setup time to RCLK1 rising edge	40	—	40	—	40	—	ns
107	RXD2 hold time from RCLK1 rising edge <sup>2</sup>	0	—	0	—	0	—	ns
108	$\overline{CD1}$ setup time to RCLK1 rising edge	40	—	40	—	40	—	ns

NOTES:

1. The ratio SyncCLK/RCLK1 and SyncCLK/TCLK1 must be greater than or equal to 3/1.
2. Applies to  $\overline{CD}$  and  $\overline{CTS}$  hold time when they are used as external sync signals.

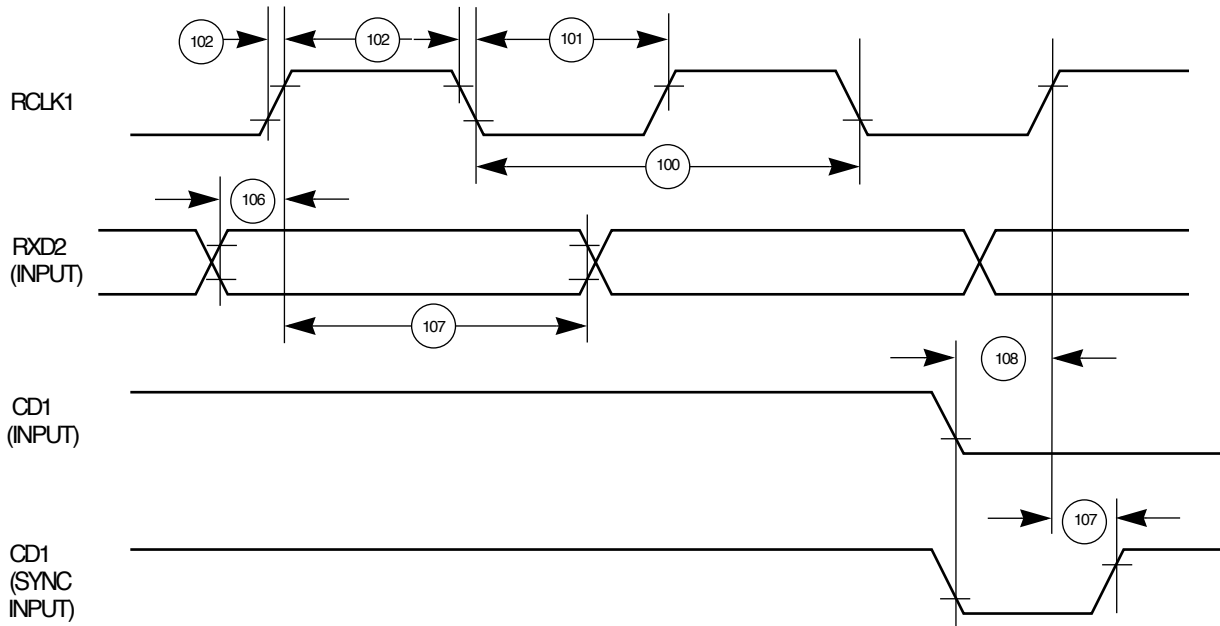
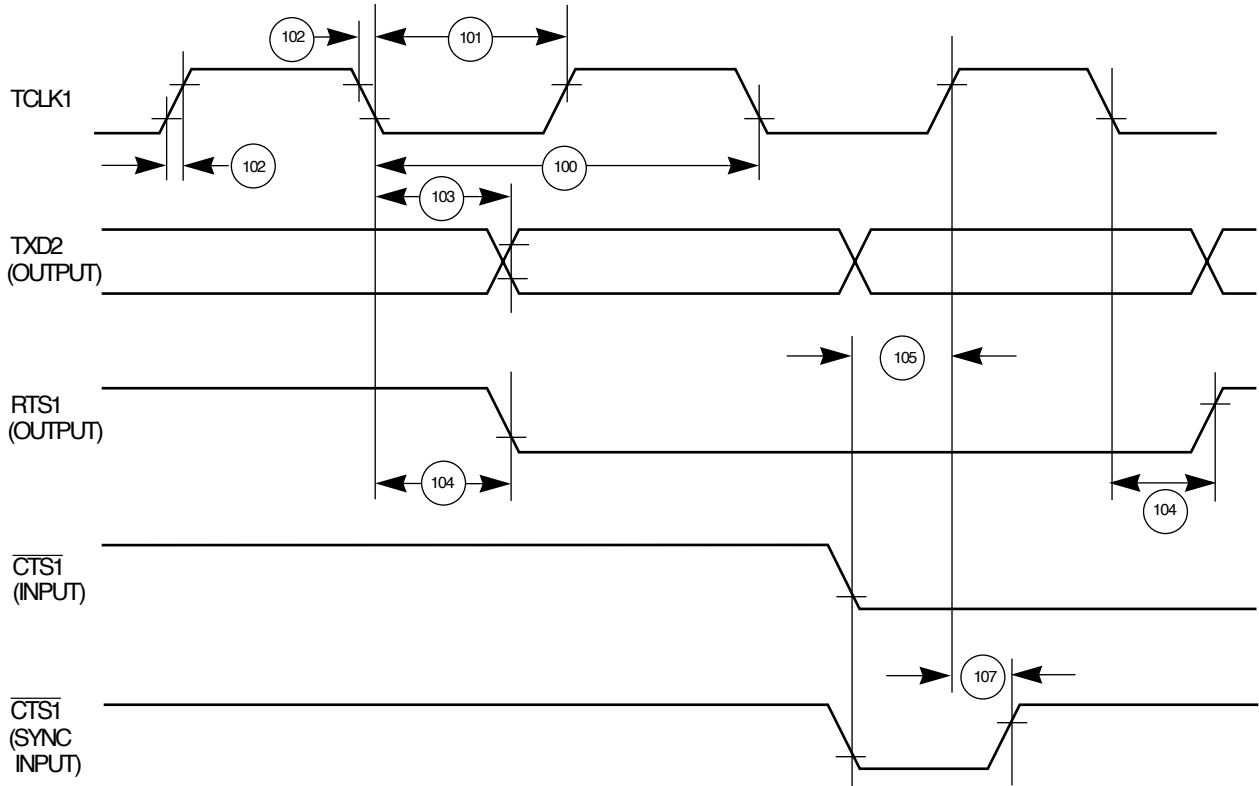

Figure 46. SCC NMSI Receive Timing Diagram



**Figure 47. SCC NMSI Transmit Timing Diagram**

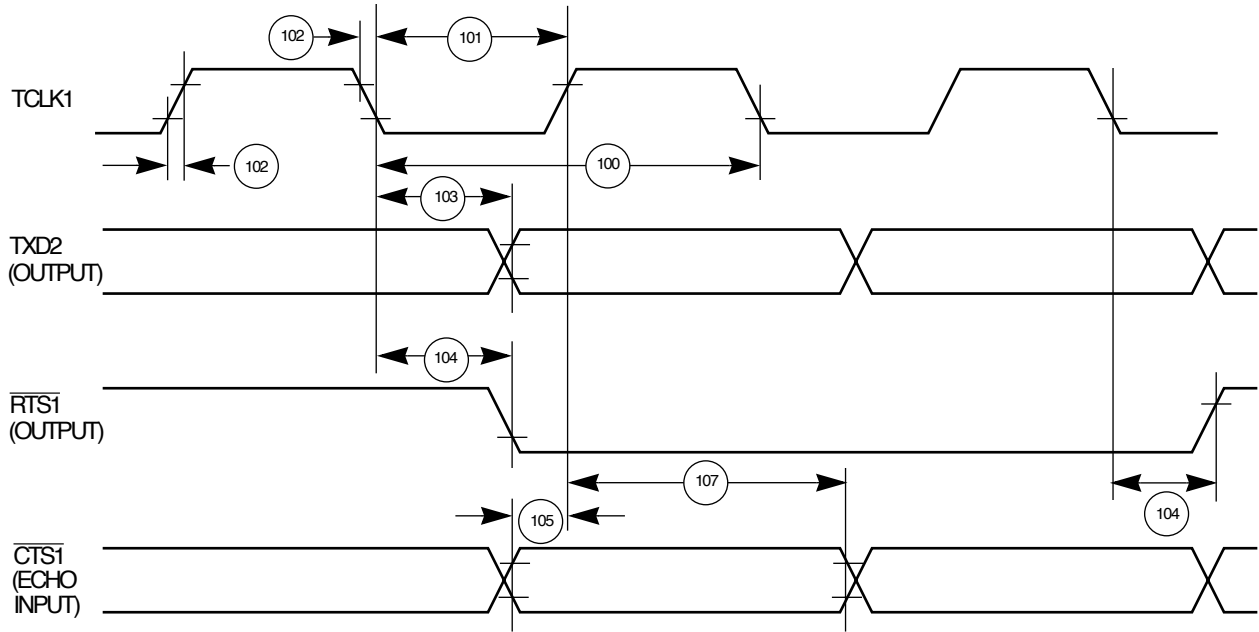

Figure 48. HDLC Bus Timing Diagram

**Table 15. Ethernet Timing**

NUM	CHARACTERISTIC	25MHZ		40MHZ		50MHZ		UNIT
		MIN	MAX	MIN	MAX	MIN	MAX	
120	CLSN (CTS2) width high	40	—	40	—	40	—	ns
121	RCLK1 rise and fall times	—	15	—	15	—	15	ns
122	RCLK1 width low	40	—	40	—	40	—	ns
123	RCLK1 clock period <sup>1</sup>	80	120	80	120	80	120	ns
124	RXD2 setup time	20	—	20	—	20	—	ns
125	RXD2 hold time	5	—	5	—	5	—	ns
126	RENA (CD2) active delay (from RCLK1 rising edge of the last data bit)	10	—	10	—	10	—	ns
127	RENA (CD2) width low	100	—	100	—	100	—	ns
128	TCLK1 rise and fall times	—	15	—	15	—	15	ns
129	TCLK1 width low	40	—	40	—	40	—	ns
130	TCLK1 clock period <sup>1</sup>	99	101	99	101	99	101	ns
131	TXD2 active delay (from TCLK1 rising edge)	10	50	10	50	10	50	ns
132	TXD2 inactive delay (from TCLK1 rising edge)	10	50	10	50	10	50	ns
133	TENA (RTS2) active delay (from TCLK1 rising edge)	10	50	10	50	10	50	ns
134	TENA (RTS2) inactive delay (from TCLK1 rising edge)	10	50	10	50	10	50	ns
135	N/A							
136	N/A							
137	N/A							
138	CLKx low to $\overline{SDACK}$ asserted <sup>2</sup>	—	20	—	20	—	20	ns
139	CLKx low to $\overline{SDACK}$ negated <sup>3</sup>	—	20	—	20	—	20	ns

**NOTES:**

1. The ratio SyncCLK/RCLK1 and SyncCLK/TCLK1 must be greater than or equal to 2/1.
2.  $\overline{SDACK}$  is asserted when the SDMA writes the incoming frame DA into memory.

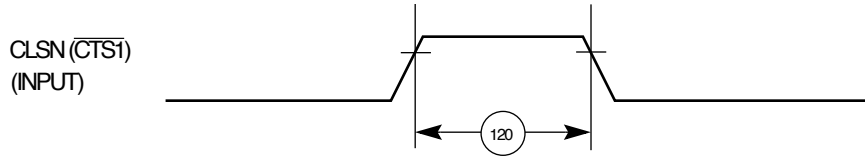

Figure 49. Ethernet Collision Timing Diagram

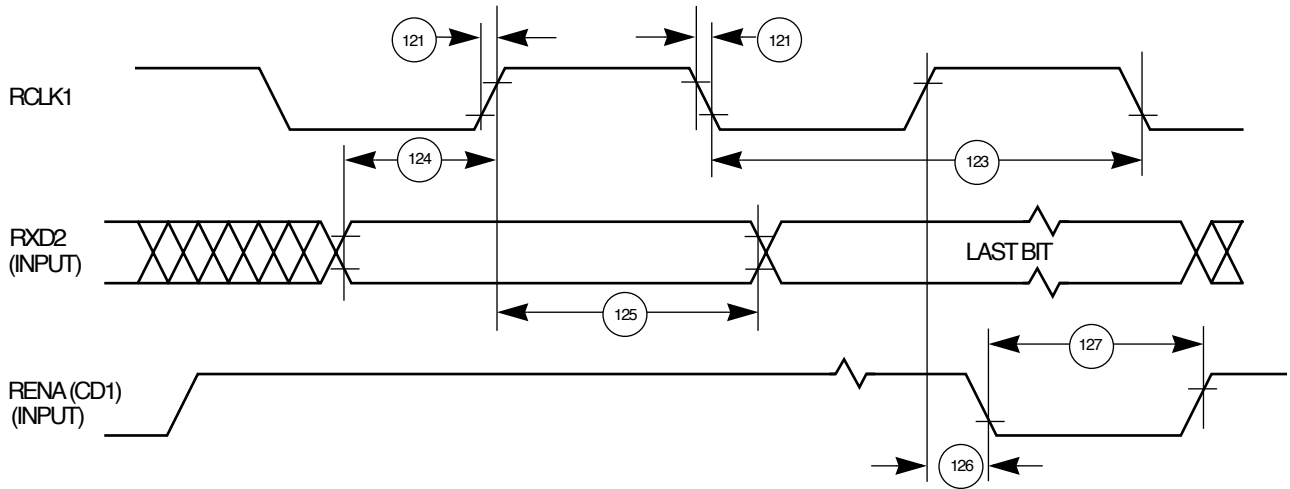
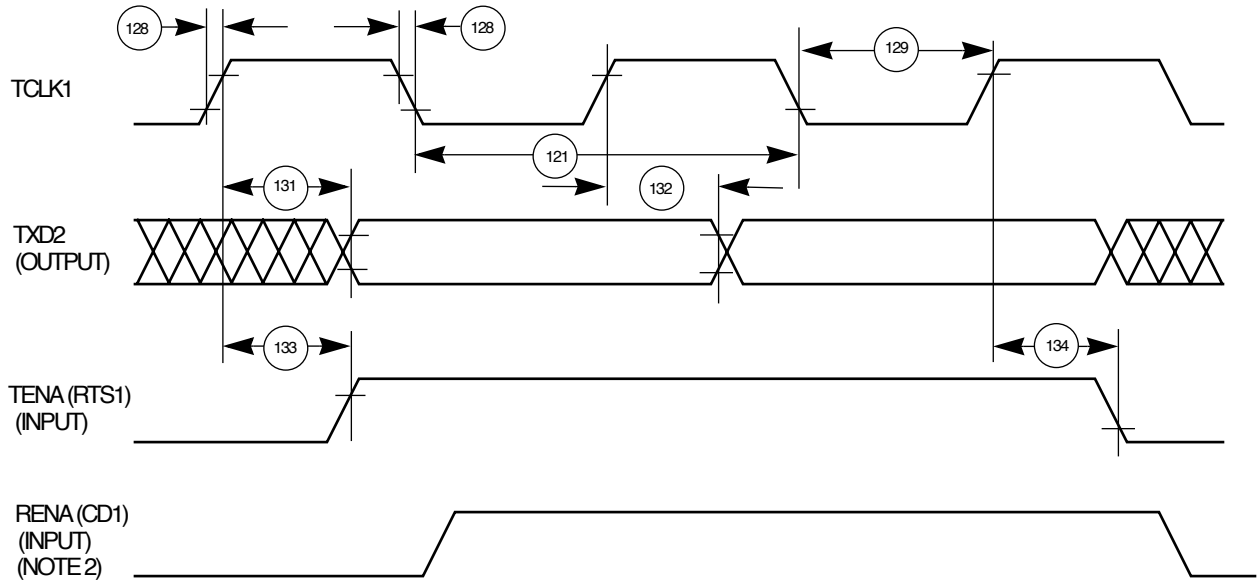

Figure 50. Ethernet Receive Timing Diagram



- NOTES: 1. TRANSMIT CLOCK INVERT (TCI) BIT IN THE GSMR IS SET.  
 2. IF RENA IS DEASSERTED BEFORE TENA, OR RENA IS NOT ASSERTED AT ALL DURING TRANSMIT, THEN THE CSL BIT IS SET IN THE BUFFER DESCRIPTOR AT THE END OF FRAME TRANSMISSION.

**Figure 51. Ethernet Transmit Timing Diagram**



Table 16. Serial Peripheral Interface Master Timing

NUM	CHARACTERISTIC	25MHZ		40MHZ		50MHZ		UNIT
		MIN	MAX	MIN	MAX	MIN	MAX	
160	Master cycle time	4	1,024	4	1,024	4	1,024	tcyc
161	Master clock (SCK) high or low time	2	512	2	512	2	512	tcyc
162	Master data setup time (inputs)	50	—	50	—	50	—	ns
163	Master data hold time (inputs)	0	—	0	—	0	—	ns
164	Master data valid (after SCK edge)	—	20	—	20	—	20	ns
165	Master data hold time (outputs)	0	—	0	—	0	—	ns
166	Rise time output	—	15	—	15	—	15	ns
167	Fall time output	—	15	—	15	—	15	ns

NOTE: The ratio SyncCLK/SMCLK must be greater than or equal to 2/1.

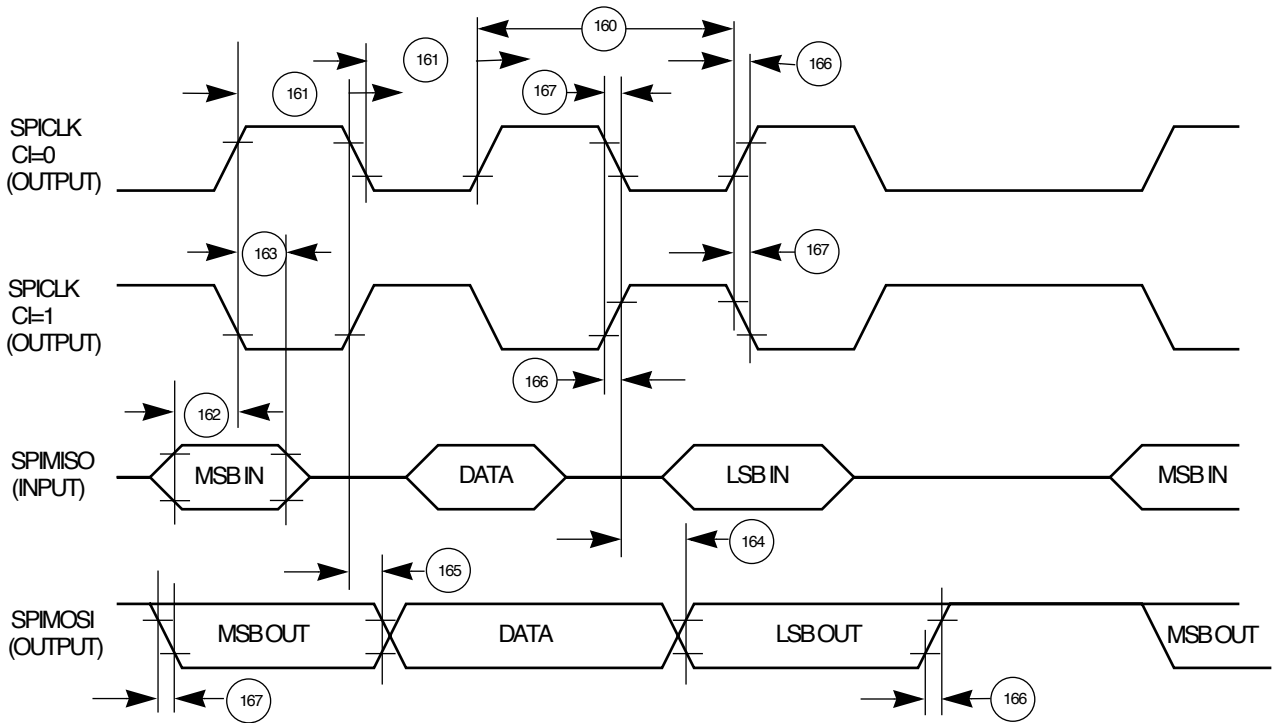

Figure 52. SPI Master (CP=0) Timing Diagram

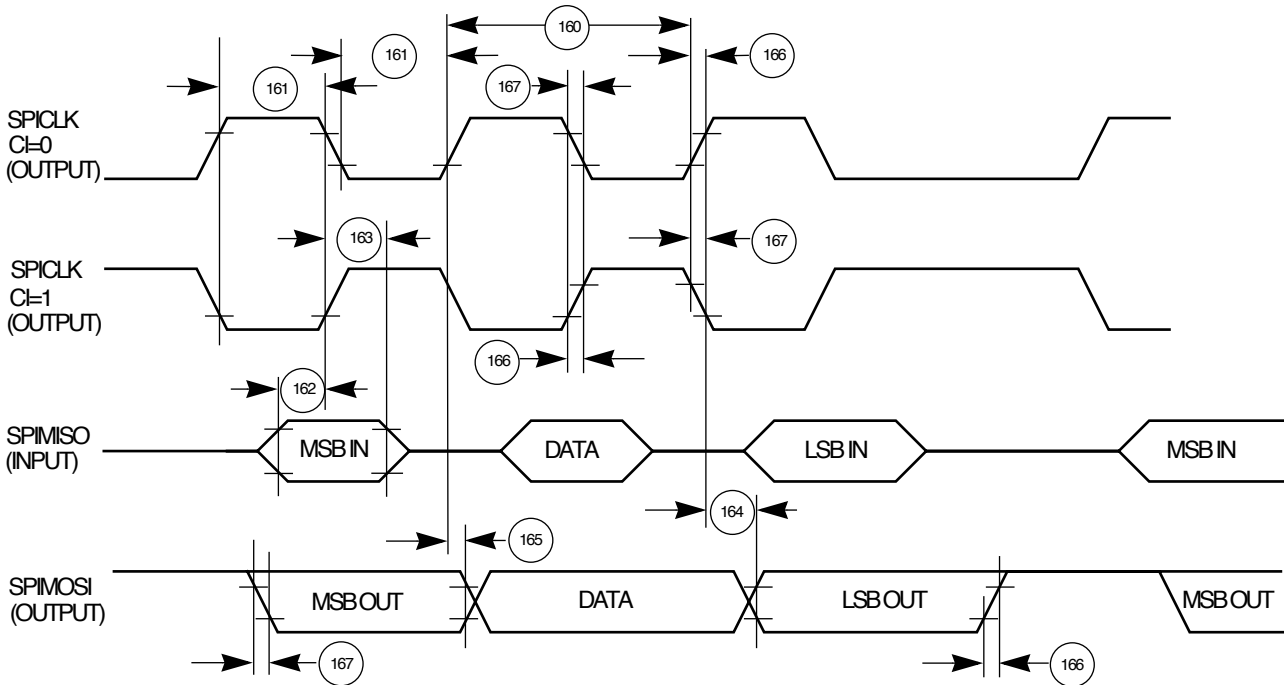

Figure 53. SPI Master (CP=1) Timing Diagram

**Table 17. Serial Peripheral Interface Slave Timing**

NUM	CHARACTERISTIC	25MHZ		40MHZ		50MHZ		UNIT
		MIN	MAX	MIN	MAX	MIN	MAX	
170	Slave cycle time	2	—	2	—	2	—	tcyc
171	Slave enable lead time	15	—	15	—	15	—	ns
172	Slave enable lag time	15	—	15	—	15	—	ns
173	Slave clock (SPICLK) high or low time	1	—	1	—	1	—	tcyc
174	Slave sequential transfer delay (does not require deselect)	1	—	1	—	1	—	tcyc
175	Slave data setup time (inputs)	20	—	20	—	20	—	ns
176	Slave data hold time (inputs)	20	—	20	—	20	—	ns
177	Slave access time	—	50	—	50	—	50	ns
178	Slave SPI MISO disable time	—	50	—	50	—	50	ns
179	Slave data valid (after SPICLK edge)	—	50	—	50	—	50	ns
180	Slave data hold time (outputs)	0	—	0	—	0	—	ns
181	Rise time (input)	—	15	—	15	—	15	ns
182	Fall time (input)	—	15	—	15	—	15	ns

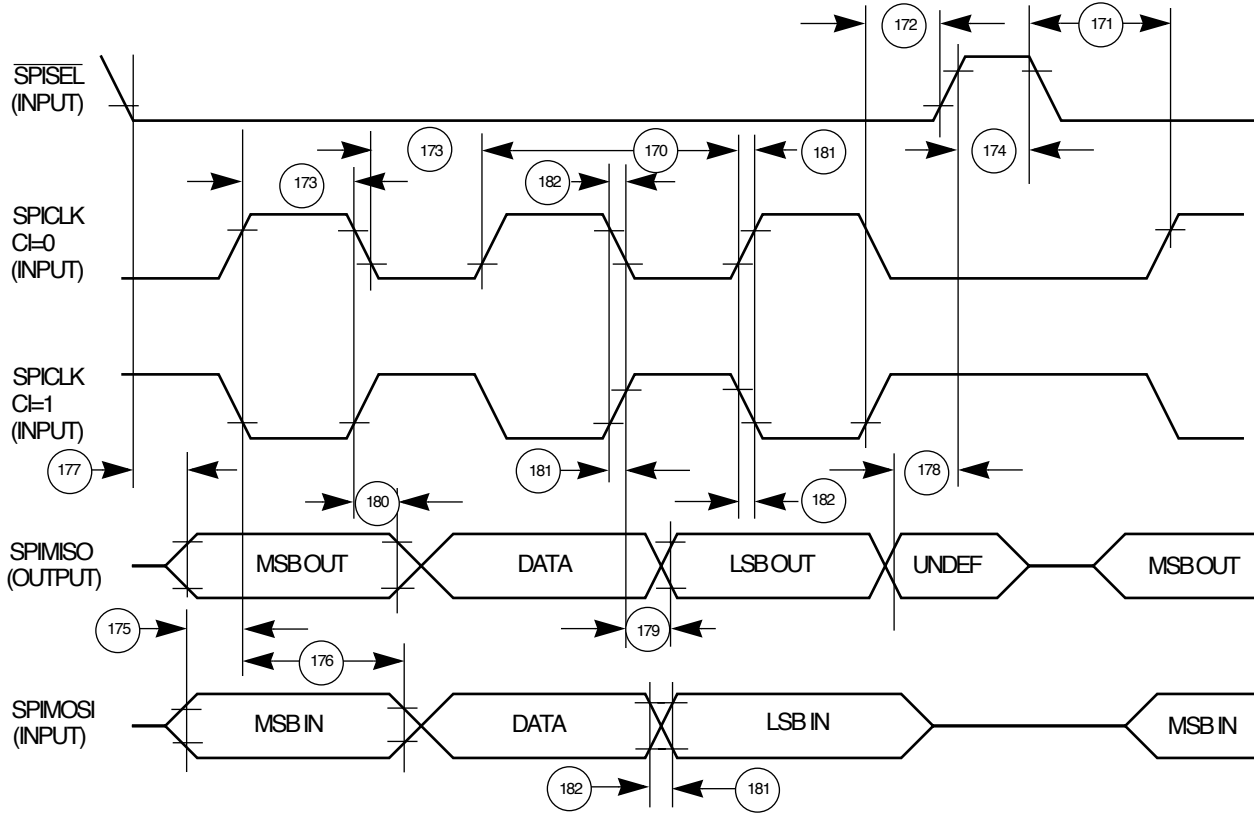

Figure 54. SPI Slave (CP=0) Timing Diagram

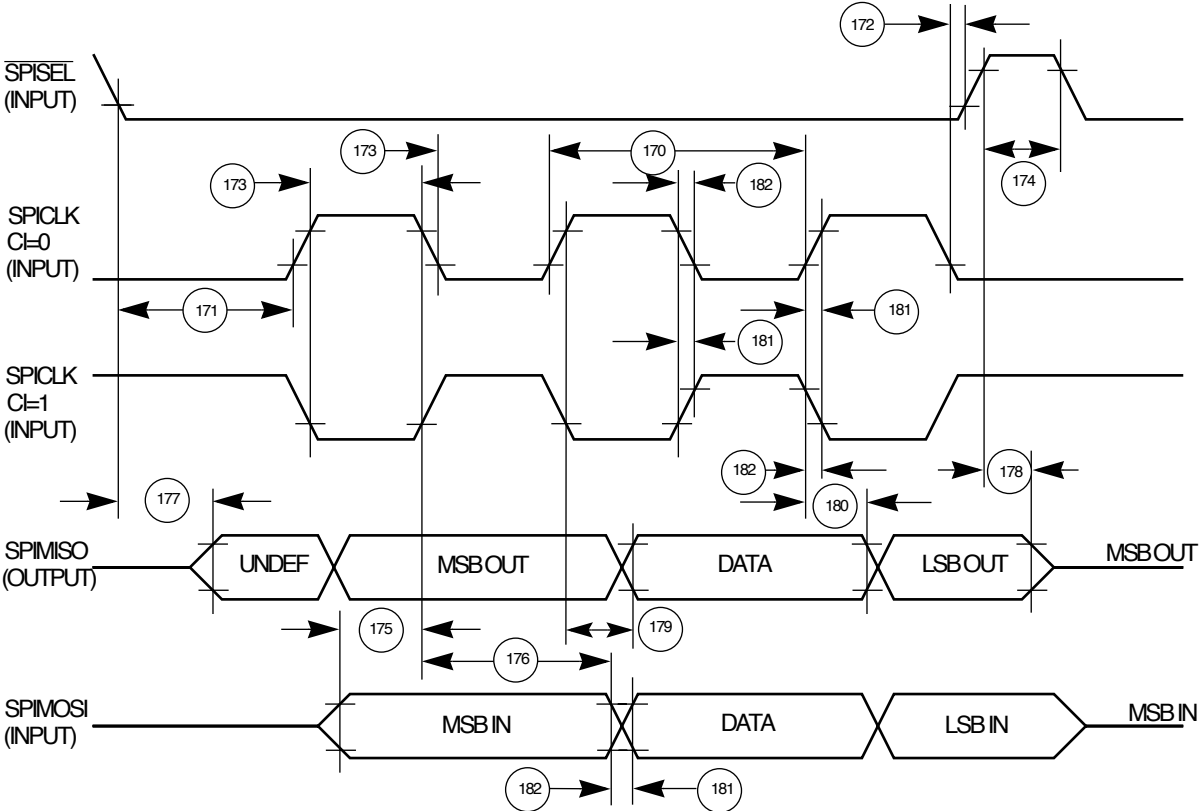

Figure 55. SPI Slave (CP=1) Timing Diagram

Freescale Semiconductor, Inc.

**Table 18. I<sup>2</sup>C Timing—SCL < 100 kHz**

NUM	CHARACTERISTIC	25MHZ		40MHZ		50MHZ		UNIT
		MIN	MAX	MIN	MAX	MIN	MAX	
200	SCL clock frequency (slave)	0	100	0	100	0	100	kHz
200	SCL clock frequency (master)	1.5	100	1.5	100	1.5	100	kHz
202	Bus free time between transmissions	4.7	—	4.7	—	4.7	—	μs
203	Low period of SCL	4.7	—	4.7	—	4.7	—	μs
204	High period of SCL	4.0	—	4.0	—	4.0	—	μs
205	Start condition setup time	4.7	—	4.7	—	4.7	—	μs
206	Start condition hold time	4.0	—	4.0	—	4.0	—	μs
207	Data hold time	0	—	0	—	0	—	μs
208	Data setup time	250	—	250	—	250	—	ns
209	SDL/SCL rise time	—	1	—	1	—	1	μs
210	SDL/SCL fall time	—	300	—	300	—	300	ns
211	STOP condition setup time	4.7	—	4.7	—	4.7	—	μs

NOTE: SCL frequency is given by  $SCL = BRGCLK\_frequency / ((BRG\ register + 3) * pre\_scaler * 2)$ .  
The ratio  $SyncClk / (BRGCLK / pre\_scaler)$  must be greater than or equal to 4/1.

**Table 19. I<sup>2</sup>C Timing—SCL > 100 kHz**

NUM	CHARACTERISTIC	MINIMUM	MAXIMUM	UNIT
200	SCL clock frequency (slave)	0	BRGCLK/48	Hz
200	SCL clock frequency (master)	BRGCLK/16512	BRGCLK/48	Hz
202	Bus free time between transmissions	$1 / (2.2 * fSCL)$	—	sec
203	Low period of SCL	$1 / (2.2 * fSCL)$	—	sec
204	High period of SCL	$1 / (2.2 * fSCL)$	—	sec
205	Start condition setup time	$1 / (2.2 * fSCL)$	—	sec
206	Start condition hold time	$1 / (2.2 * fSCL)$	—	sec
207	Data hold time	0	—	sec
208	Data setup time	$1 / (40 * fSCL)$	—	sec
209	SDL/SCL rise time	—	$1 / (10 * fSCL)$	sec
210	SDL/SCL fall time	—	$1 / (33 * fSCL)$	sec
211	Stop condition setup time	$1 / (2.2 * fSCL)$	—	sec

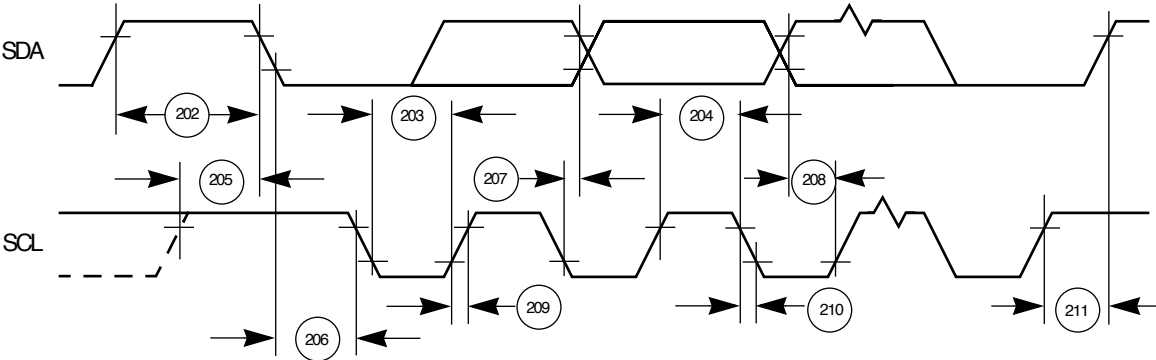
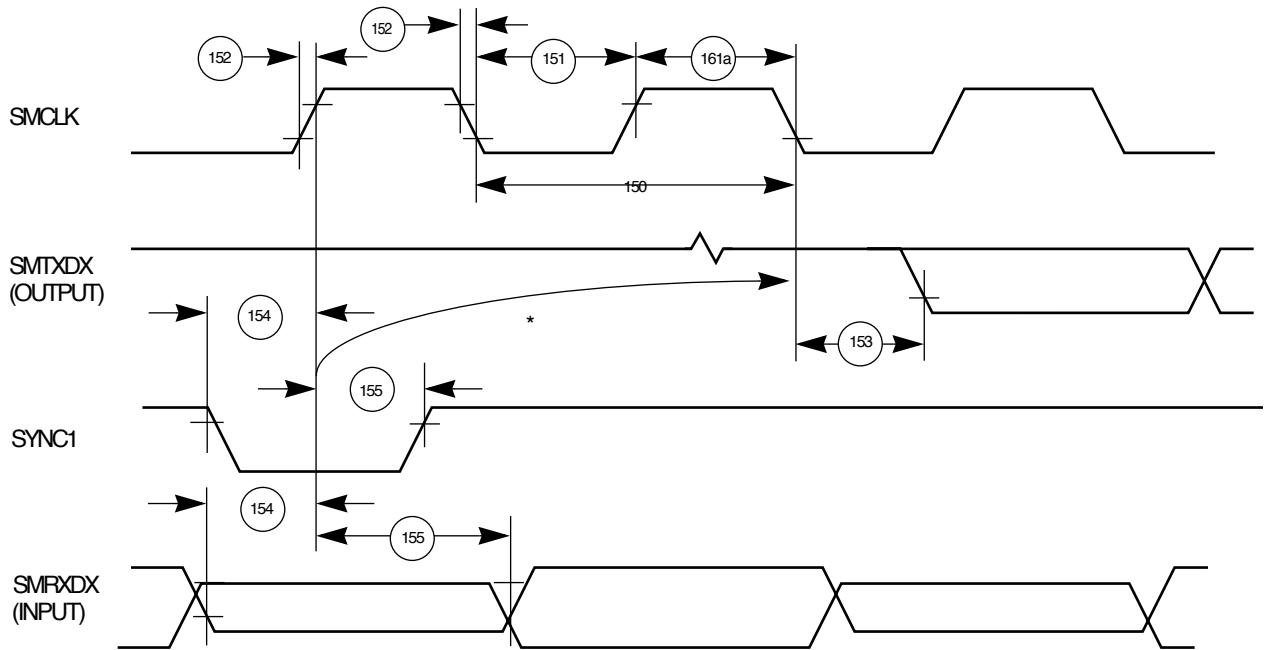

Figure 56. I<sup>2</sup>C Bus Timing Diagram

**Table 20. Serial Management Controller Timing**

NUM	CHARACTERISTIC	25MHZ		40MHZ		50MHZ		UNIT
		MIN	MAX	MIN	MAX	MIN	MAX	
150	CLK1 clock period	100	—	100	—	100	—	ns
151	CLK1 width low	50	—	50	—	50	—	ns
151A	CLK1 width high	50	—	50	—	50	—	ns
152	CLK1 rise and fall times	—	15	—	15	—	15	ns
153	SMTXDx active delay (from CLK1 falling edge)	10	50	10	50	10	50	ns
154	SMRXDx/SYNC1 setup time	20	—	20	—	20	—	ns
155	SMRXDx/SYNC1 hold time	5	—	5	—	5	—	ns

NOTE: The ratio SyncCLK/SMCLK must be greater than or equal to 2/1.



NOTE: \* THIS DELAY IS EQUAL TO AN INTEGER NUMBER OF "CHARACTER LENGTH" CLOCKS.

**Figure 57. SMC Transparent Timing Diagram**



**Table 21. LCD Controller Timing**

NUM	CHARACTERISTIC	25MHZ		40MHZ		50MHZ		UNIT
		MIN	MAX	MIN	MAX	MIN	MAX	
220	Shift clock cycle time	40	—	40	—	40	—	nsec
221	Shift clock high time	20	—	20	—	20	—	nsec
223	CLOCK/HSYNC/VSYNC/ $\overline{OE}$ rise and fall times	—	10	—	10	—	10	nsec
224	Data valid delay from shift clock high	—	15	—	15	—	15	nsec
225	VSYNC to HSYNC setup time <sup>1</sup>	5	—	5	—	5	—	T
226	VSYNC hold time	1	—	1	—	1	—	T
227	HSYNC pulse width	4	—	4	—	4	—	T
228	Time from clock falling edge to HSYNC rising edge	4.5	—	4.5	—	4.5	—	T
229	Time from HSYNC falling edge to clock rising edge <sup>2</sup>	4	—	4	—	4	—	T
230	AC active delay	—	25	—	25	—	25	nsec
231	VSYNC pulse width (TFT)	1	16	1	16	1	16	Line
232	HSYNC to $\overline{OE}$ delay <sup>3</sup>	4	—	4	—	4	—	T
233	$\overline{OE}$ to HSYNC delay	4	—	4	—	4	—	T
234	VSYNC to $\overline{OE}$ delay (TFT)	0	1,023	0	1,023	0	1,023	T
235	VSYNC/HSYNC/ $\overline{OE}$ active delay (TFT)	—	15	—	15	—	15	nsec
236	Wait between frames <sup>4</sup>	WBF	—	WBF	—	WBF	—	Line

**NOTES:**

1. T = shift clock cycle (220).
2. This number is given for wbl(wait between lines)  $\leq 2$ . For wbl=n {n>2} the timing will be (n+2)T.
3. This number is given for wbl(wait between lines)  $\leq 2$ . For wbl=n {n>2} the timing will be (n+2)T.
4. Wait Between Frames (WBF) is a programmable parameter.

T<sub>cyc</sub> is the cycle time of the LCD clock (shift clock). T<sub>delay</sub> is a circuit delay that is specified in the AC electrical specifications. 1–16 lines is a time period that can vary between one scan line and 16, depending on how the LCD controller is programmed in the VPW field of the LCVCR. 0–1,023 lines is a time period that can vary between 0 and 1,023 scan lines in the WBF field of the LCVCR.

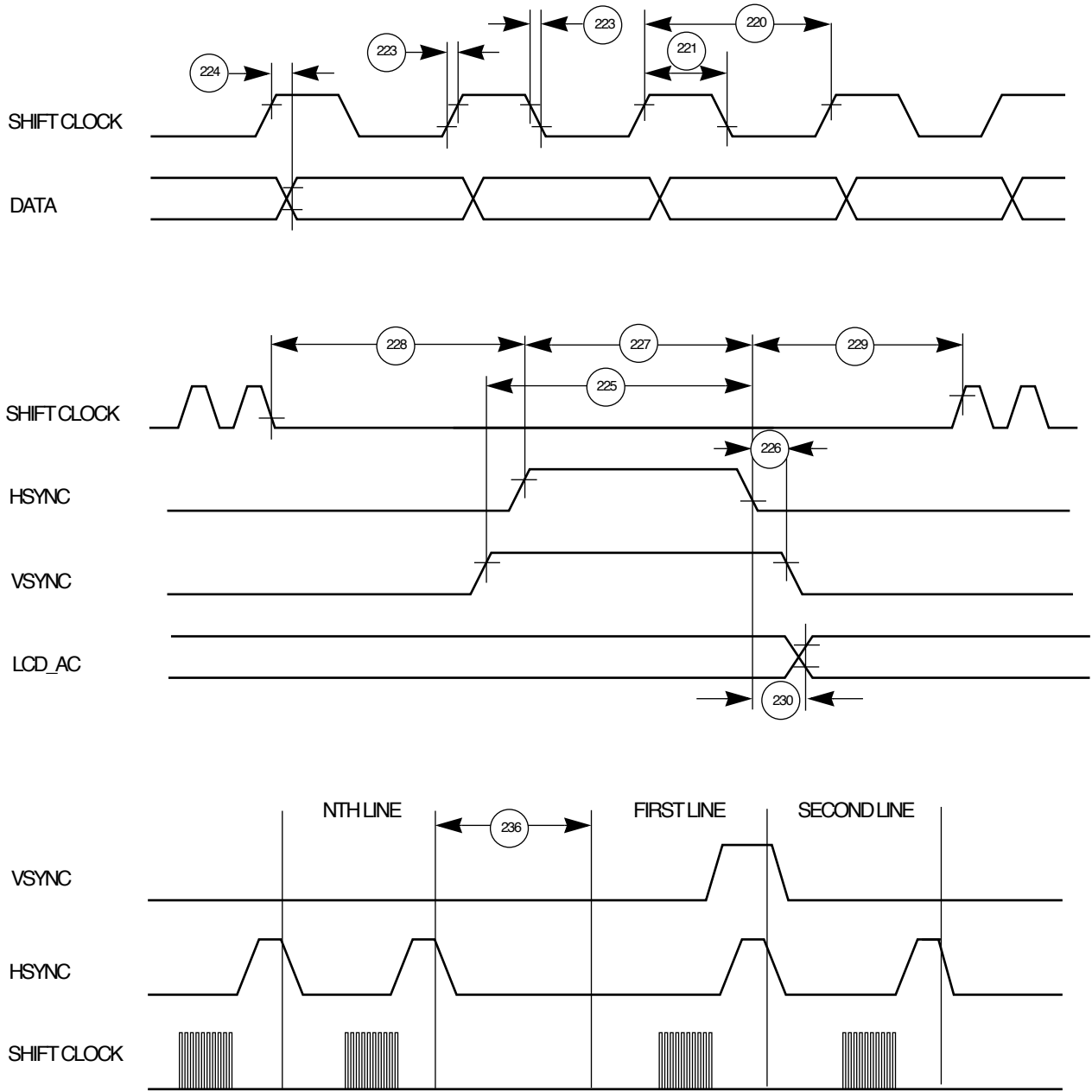

Figure 58. Passive Panel Timing Diagram

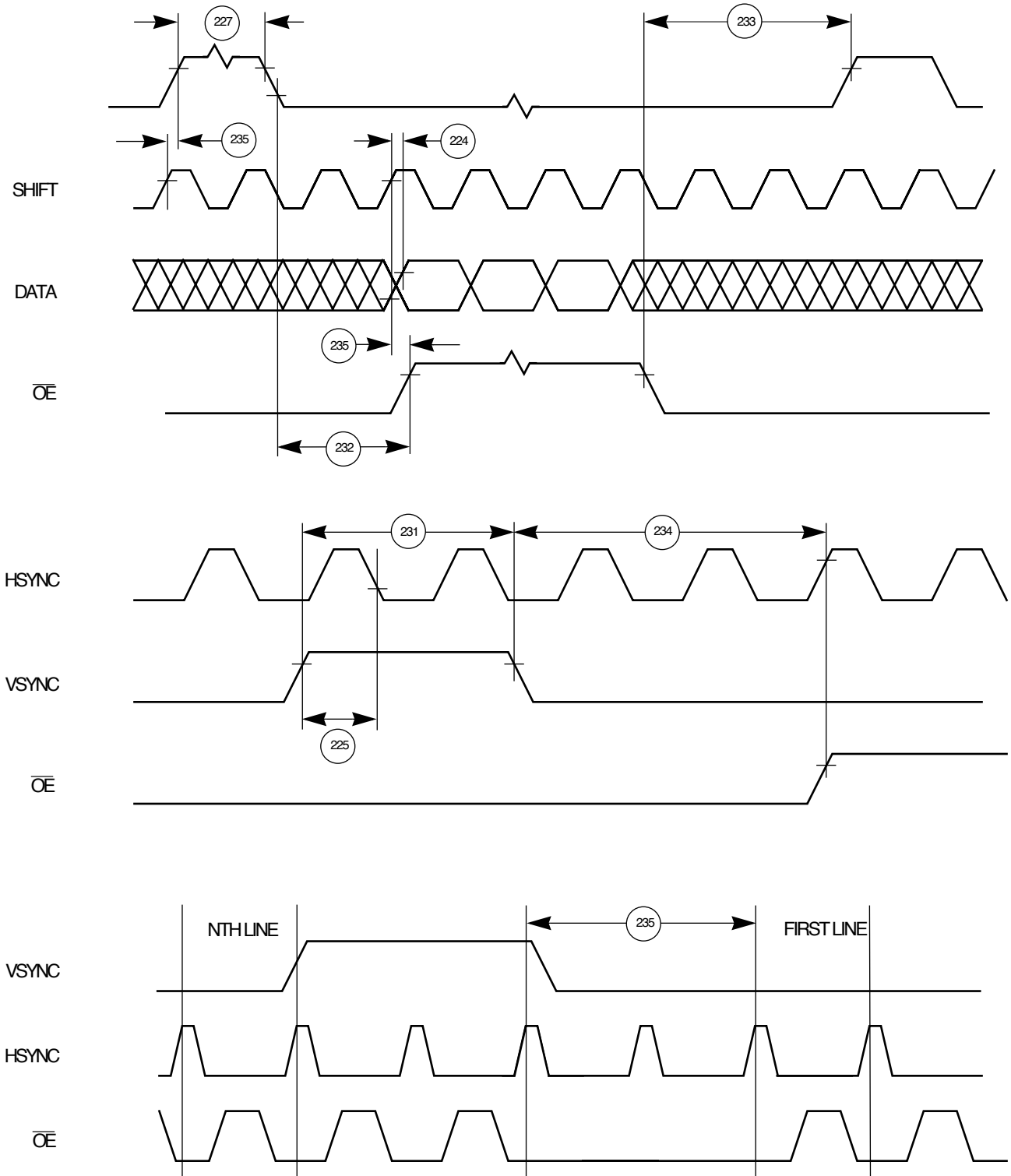
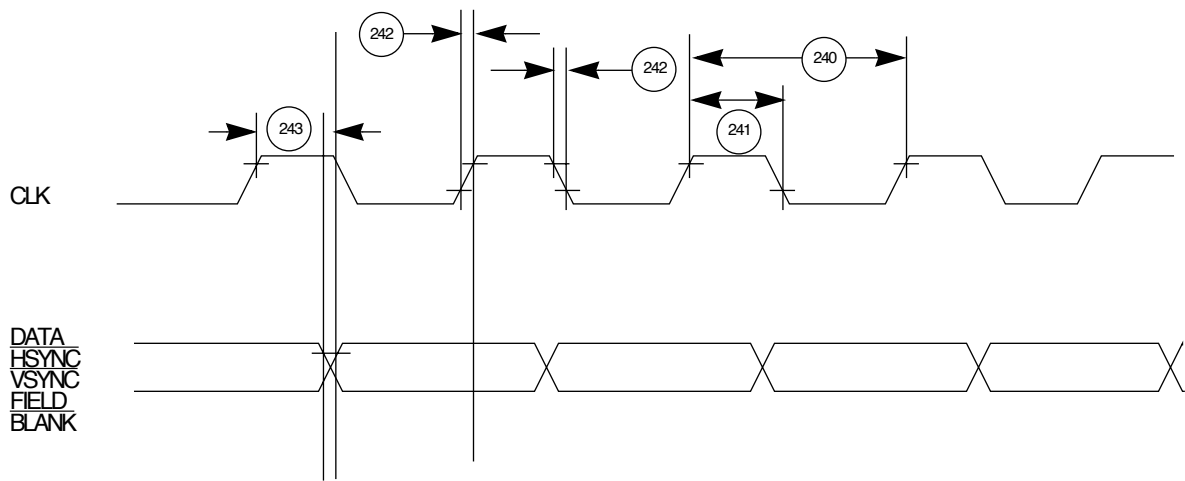

Figure 59. TFT Panel Timing Diagram

**Table 22. Video Controller Timing**

NUM	CHARACTERISTIC	25MHZ		40MHZ		50MHZ		UNIT
		MIN	MAX	MIN	MAX	MIN	MAX	
240	Clock cycle time	32	—	32	—	32	—	nsec
241	Clock high time	13	—	13	—	13	—	nsec
242	CLK/HSYNC/VSYNC/BLANK/FIELD rise and fall times	—	10	—	10	—	10	nsec
243	Clock high to data valid	10	25	10	25	10	25	nsec



**Figure 60. Video Controller Timing**





**Freescale Semiconductor, Inc.**

**Freescale Semiconductor, Inc.**

## X-ON Electronics

Largest Supplier of Electrical and Electronic Components

*Click to view similar products for [Microprocessors - MPU category](#):*

*Click to view products by [Freescale manufacturer](#):*

Other Similar products are found below :

[MC68302EH20C](#) [MC7457RX1000LC](#) [MC7457RX1267LC](#) [MC7457VG1267LC](#) [A2C00010998 A](#) [A2C52004004](#) [R5F117BCGNA#20](#)  
[R5F52106BDLA#U0](#) [ADJ3400IAA5DOE](#) [MPC8245TVV266D](#) [MPC8245TZU300D](#) [MPC8260ACVVMHBB](#) [MPC8323ECVRAFDCA](#)  
[MPC8536ECVJAVLA](#) [BOXNUC5PGYH0AJ](#) [20-668-0024](#) [P1010NSN5DFB](#) [P2010NSN2MHC](#) [P2020NXE2HHC](#) [P5020NSE7QMB](#)  
[P5020NSE7TNB](#) [P5020NSE7VNB](#) [LS1020ASN7KQB](#) [LS1020AXN7HNB](#) [LS1020AXN7KQB](#) [A2C00010729 A](#) [A2C00039344](#)  
[T1022NSE7MQB](#) [T1022NXN7PQB](#) [T1023NSE7MQA](#) [T1024NXE7PQA](#) [T1042NSE7MQB](#) [T1042NSN7MQB](#) [T1042NXN7WQB](#)  
[T2080NSE8TTB](#) [T2080NSN8PTB](#) [T2080NXE8TTB](#) [T2081NXN8TTB](#) [R5F101AFASP#V0](#) [MC68302CEH20C](#) [MPC8260ACVVMIBB](#)  
[MPC8280CZUUPEA](#) [MPC8313ECVRAFFC](#) [MPC8313ECVRAGDC](#) [MPC8313EVRADDC](#) [MPC8313EVRAFFC](#) [MPC8313VRADDC](#)  
[MPC8314CVRAGDA](#) [MPC8314VRAGDA](#) [MPC8315VRAGDA](#)