



QorIQ Multicore Processor Development

QorIQ P1010/P1014 Reference Design Board

Overview

The P1010RDB is a highly integrated reference design board that can help shorten your time to market. The reference design is aimed at low-cost networking applications (with or without trust architecture), wired and wireless access, as well as industrial and smart energy applications.

This cost-effective board is based on the QorIQ P1010 processor family and contains leading-edge external components to help you quickly design and implement your target application. The P1010RDB leverages the P1010 processor and supports both the full-featured P1010 as well as the more cost-efficient P1014 device.

P1010RDB System Block Diagram

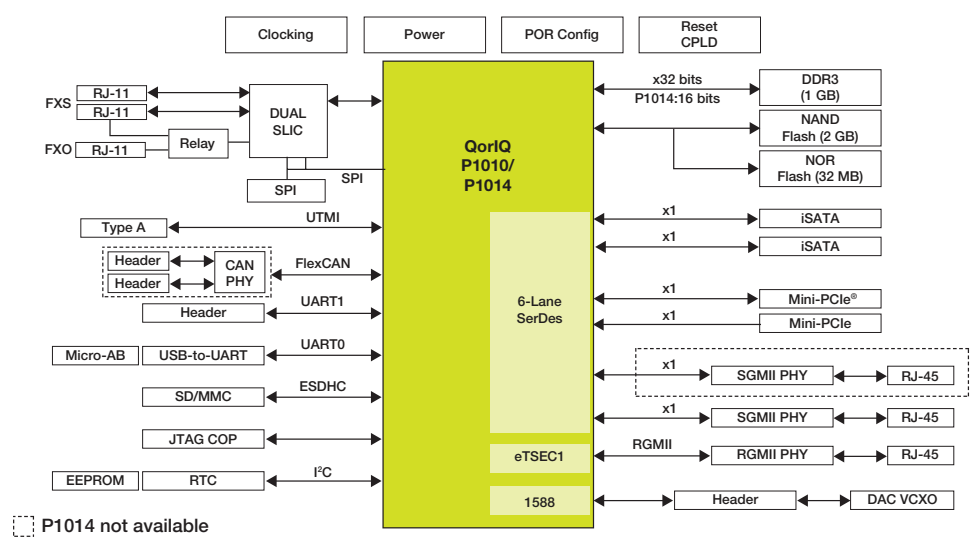

The P1010 processor family is based on the e500 core, built on Power Architecture® technology, which has a core frequency range of 533–1000 MHz, and supports a 32 KB instruction and L1 data cache and a 256 KB L2 cache. The P1010 also supports a complete trust architecture environment, CAN controllers for industrial applications, three Gigabit Ethernet controllers with IEEE® 1588 V2 support, USB 2.0 plus PHY, two PCI Express® 1.0a controllers, up to six SerDes interfaces, 16/32-bit DDR3 and DDR3L (16-bit mode supports ECC), SPI controller supporting booting from SPI, serial flash memory, SD/MMC card controller supporting booting from flash cards and an integrated security engine. The new P1010 family with built-in 45 nm process technology provides high integration for cost-efficient solutions and enables a trust platform (through trust architecture) for customers that want to preserve the hardware or software integrity of their platforms.

The P1010RDB platform features 1 GB of DDR3 SDRAM, 32 MB NOR flash and 32 MB NAND flash, and can boot securely from either NOR or NAND flash memory. Other boot options (i.e., SD/MMC, SPI) are also supported. The platform supports three Gigabit-capable ports via an SGMII or RGMII PHYs, as well as a single-port USB and associated PHY.

The P1010RDB also supports a PCI Express® add-in connector and a MiniPCI Express slot, as well as an SD/MMC card slot. These components, integrated with the P1010 family, provide an application-specific platform that can help you get a jump start on your next application design. In addition, the P1010RDB provides a simplified migration path for existing PowerQUICC or PowerQUICC Pro processor customers wishing to migrate to QorIQ multicore processors. Customers can migrate to the single-core P1014 processor as a stepping stone on their way to a full-featured P1010 processor.

Since the P1010 product is pin-compatible with the P1014, only one version of the board is available with options on the board support package to target either processor.

Along with the hardware support, the P1010RDB comes with a board support package (BSP) that includes both the U-boot and Linux® 2.6 operating system support. The platform is also available with third-party software applications. For a demonstration or for details of Freescale third-party applications for this platform, please contact your local Freescale sales office.

P1010RDB Board Features

Memory

- 1 GB DDR3 (8-bit x 4 chips), supports up to 8 GB on-board DDR3 SDRAM
- 32 MB (16-bit) NOR flash memory
- 32 MB SLC NAND flash memory
- 256 KB I²C EEPROM
- 128 MB SPI flash
- SD/MMC connector to interface with the SD memory card

PCI Express

- One standard PCI Express connector
- One mini PCI Express connector

SATA

- One internal SATA connected to 2.5" 160 G SATA 2 HDD
- One eSATA connector to rear panel

USB 2.0

- One USB 2.0 port connected via UTMI PHY to mini AB interface
- One USB 2.0 port directly connected to mini AB interface

Three 10/100/1000 Ports

- eTSEC 1 connected to RGMII PHY
- eTSEC 2 and 3 connected to SGMII PHY

Flex CAN

- Two connectors for field bus interface

UART

- DUART interface, terminated as RJ45 connectors

TDM

- Two FXS ports connected via an external SLIC to the TDM interface
- One FXO port connected via a relay to FXS for switchover to POTS

Others

- LEDs: Power (green), link (green), activities (yellow)
- JTAG for debugging
- IEEE 1588 V2 signals for test and measurement

Form Factor

- Mini ITX form factor



For more information, please visit freescale.com/QorIQ

Freescale, the Freescale logo, PowerQUICC and QorIQ are trademarks of Freescale Semiconductor, Inc., Reg. U.S. Pat. & Tm. Off. All other product or service names are the property of their respective owners. The Power Architecture and Power.org word marks and the Power and Power.org logos and related marks are trademarks and service marks licensed by Power.org. © 2011, 2013 Freescale Semiconductor, Inc.

Document Number: P1010RDBFS REV 1

X-ON Electronics

Largest Supplier of Electrical and Electronic Components

Click to view similar products for CPU - Central Processing Units category:

Click to view products by Freescale manufacturer:

Other Similar products are found below :

[AT80612003090AAS LBWJ](#) [B4860NSE7QUMD](#) [NPIXP2855AB-S-LA88](#) [IVPX7225-RTM-1](#) [96MPI5-2.9-6M10T](#) [2SC4646D-AN](#)
[SMBV1061LT1G](#) [2SC4646E-AN](#) [2SJ268-DL-E](#) [CP80617003981AHS LBTQ](#) [MATXM-CORE-411-HTSNK](#) [TEC0193BPF](#) [TND516SS-TL-E](#)
[BGSF 1717MN26 E6327](#) [D8086-2](#) [LF80538GF0282M-S-L8VY](#) [CM8063401293902S R1A4](#) [CM8063501521302S R1B8](#)
[CM8066201919901 SR2L0](#) [CM8066201928505 SR2HT](#) [CPH5855-TL-E](#) [CM8063501293200S R1A0](#) [AV8063801129600S R10F](#) [EMS36-02-](#)
[2H-MDT](#) [EMM04-MDT](#) [NG80386DX33](#) [NHIXP432AC](#) [NK80530MZ866256S-L7XH](#) [P1021NXE2HFB](#) [R0K5ML001SS00BR](#)
[LC87F2608A](#) [LC87FBK08A](#) [PRIXP425BC](#) [PRIXP423BB](#) [CM8066201921712S R2LF](#) [CM8064601467102S R152](#) [CM8063501375800S](#)
[R1AX](#) [CM8063501293506S R1A2](#) [CM8063401293802S R1A3](#) [CM8062107185405S R0KM](#) [LC87F0G08A](#) [CM8067702867061S R374](#) [PB-](#)
[8SMB](#) [COMX-300-HSP](#) [RTM-ATCA-7360](#) [96MPI7-3.4-8M11T](#) [CM8066002023801S R2J1](#) [96MPP-2.3-3M10T](#) [96MPI7-3.4-8M11T1](#)
[96MPXE-2.0-15M20T](#)