

Future Technology Devices International Limited Datasheet LC231X Development Module

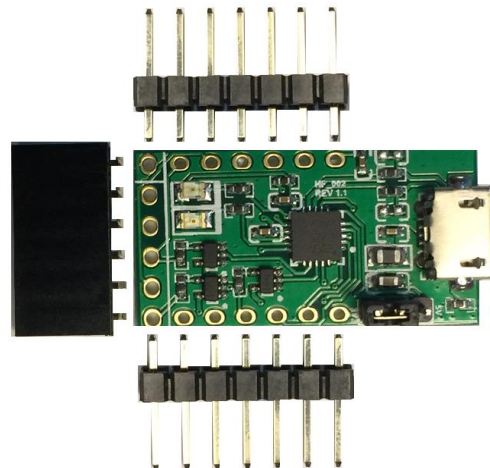

1 Introduction

The LC231X module is a low cost USB to UART bridge using FTDI's FT231X to transfer data at up to 3M Baud. Ideal for programming Arduino Pro, ESP modules etc.. It also provides the pinout which follows the industry standard FTDI TTL cable interface. The module provides the UART interface with full modem handshaking control too.

The LC231X IO interface also provides the option to output 5V power to external hardware. The interface IO levels may be set to either set to 3V3 or 5V by an on-board jumper with no soldering / de-soldering required. In 5V mode, outputs are rail to rail for maximum reliability.

The LC231X module provides 2 interface options. One is a 1X6 pin right angle socket header which follows the industry standard FTDI TTL cable interface for basic UART signals(RXD, TXD, RTS, CTS, Power and GND). The other is the full UART plus modem handshake control signals, mapped to two rows of 1x7 pin headers. Note the user cannot fit all connectors at the same time. The two header rows are spaced 0.5" apart along the sides of the board, which allows the module to plug into a solderless breadboard. Each module is supplied with one right angle socket and two 7pin headers included. The user can select which ones to fit.

Furthermore there are TX and RX LEDs to indicate data transmission on the UART signals.

1.1 Features

The LC231X module utilises the FT231X from FTDI. For a full list of the FT231X's features refer to the [FT231X](#) datasheet.

In addition, the LC231X has the following features:

- Small PCB size as 15.24mm X 28.19mm
- Configurable IO voltage interface
- USB 2.0 full speed
- Provides a full modem control interface
- Low supply current :10mA
- Supported baud rates: 300 bps to 3 Mbps
- Power output to external logic 5V/3V3
- Provides two I/O header options:
 - One 1X6 pin right angle socket header for standard FTDI TTL cable interface,
 - Or two rows of 1x7 pin headers for full modem handshake control and GPIO functions.
- -40°C to +85°C operational temperature range
- Full RoHS compliance

Neither the whole nor any part of the information contained in, or the product described in this manual, may be adapted or reproduced in any material or electronic form without the prior written consent of the copyright holder. This product and its documentation are supplied on an as-is basis and no warranty as to their suitability for any particular purpose is either made or implied. Future Technology Devices International Ltd will not accept any claim for damages howsoever arising as a result of use or failure of this product. Your statutory rights are not affected. This product or any variant of it is not intended for use in any medical appliance, device or system in which the failure of the product might reasonably be expected to result in personal injury. This document provides preliminary information that may be subject to change without notice. No freedom to use patents or other intellectual property rights is implied by the publication of this document. Future Technology Devices International Ltd, Unit 1, 2 Seaward Place, Centurion Business Park, Glasgow G41 1HH United Kingdom. Scotland Registered Company Number: SC136640

2 Typical Applications

- USB to UART bridge
- Debugger / Programmer for embedded MCU e.g. Arduino
- USB IO extender for small 8-bit micro's

2.1 Driver Support

The LC231X requires USB drivers (listed below), available free from <http://www.ftdichip.com>, which are used to make the module appear as a virtual COM port (VCP). This allows the user to communicate with the USB interface via a standard PC serial emulation port (for example TTY). Another FTDI USB driver, the D2XX driver, can also be used with application software to directly access the LC231X through a DLL. Both VCP and D2XX drivers support Windows auto-update.

Royalty free VIRTUAL COM PORT (VCP) DRIVERS for...

- Windows 10 32,64-bit
- Windows 8/8.1 32,64-bit
- Windows 7 32,64-bit
- Windows CE 4.2, 5.0 and 6.0
- Windows Server 2003, 2008 R2, 2012
- Mac OS-X
- Linux 2.4 and greater

Royalty free D2XX Direct Drivers (USB Drivers + DLL S/W Interface)

- Windows 10 32,64-bit
- Windows 8/8.1 32,64-bit
- Windows 7 32,64-bit
- Windows CE 4.2, 5.0 and 6.0
- Windows Server 2003, 2008 R2, 2012
- MAC OS-X
- Linux 2.4 and greater
- Android(J2xx)

For driver installation, please refer to the installation guides on our website:

<http://www.ftdichip.com/Support/Documents/InstallGuides.htm>

3 Ordering Information

Part No.	Description
LC231X	Low cost FT231X USB to UART module

Table of Contents

1	Introduction	1
1.1	Features.....	1
2	Typical Applications	2
2.1	Driver Support	2
3	Ordering Information	2
4	Pin Out and Signal Description	4
4.1	Module Description	4
4.2	Module Interface Signal Description.....	5
5	Devices Characteristics and Ratings.....	7
5.1	Electrical Specification	7
6	Board Schematic	8
7	Mechanical Dimensions	10
8	Contact Information.....	11
	Appendix A – References	11
	Document References	12
	Acronyms and Abbreviations	12
	Appendix B - List of Figures and Tables	12
	List of Tables.....	13
	List of Figures	13
	Appendix C – Revision History	14

4 Pin Out and Signal Description

4.1 Module Description

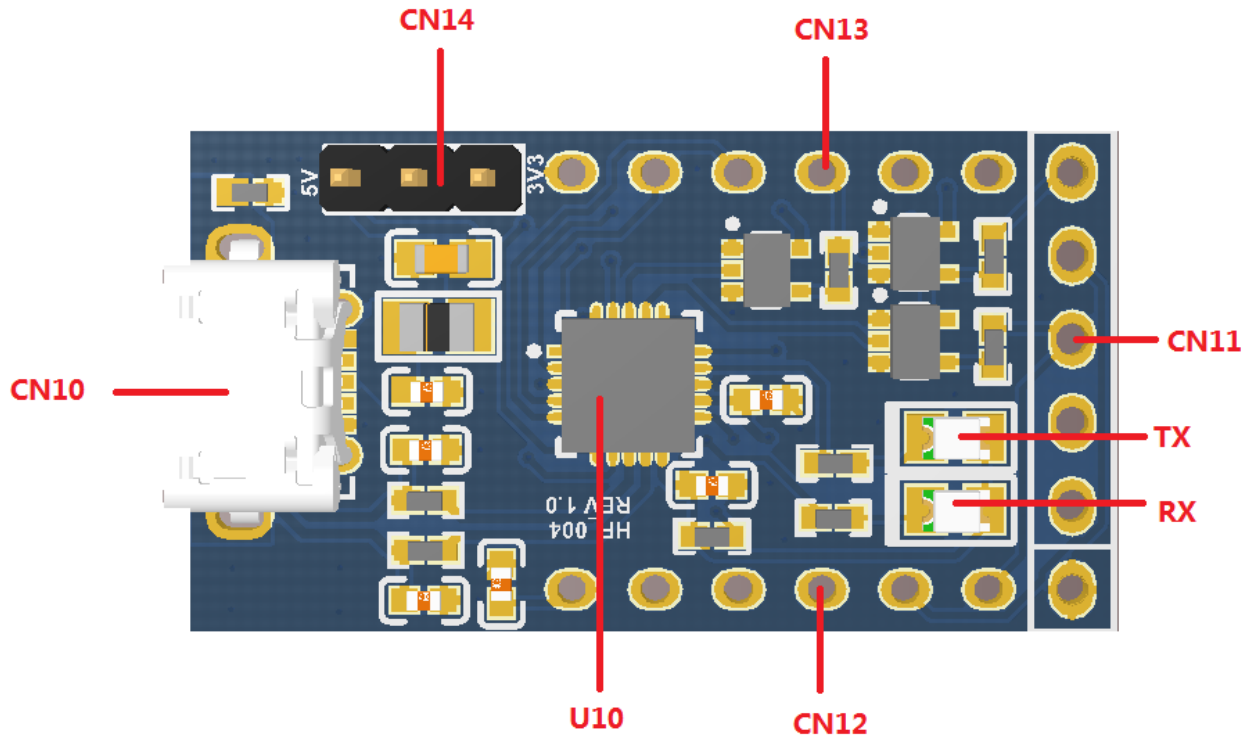

Figure 1 - Module Features

Feature	Reference Designator
Micro USB connector	CN10
IO voltage selection	CN14
6pin 2.54mm pitch connector UART interface	CN11
7pin 2.54mm pitch connector full modem control interface	CN12
7pin 2.54mm pitch connector full modem control interface	CN13
FT231X USB to serial bridge IC	U10
Green color LED	RX
Red color LED	TX

Table 1 - Module Features & Description

4.2 Module Interface Signal Description

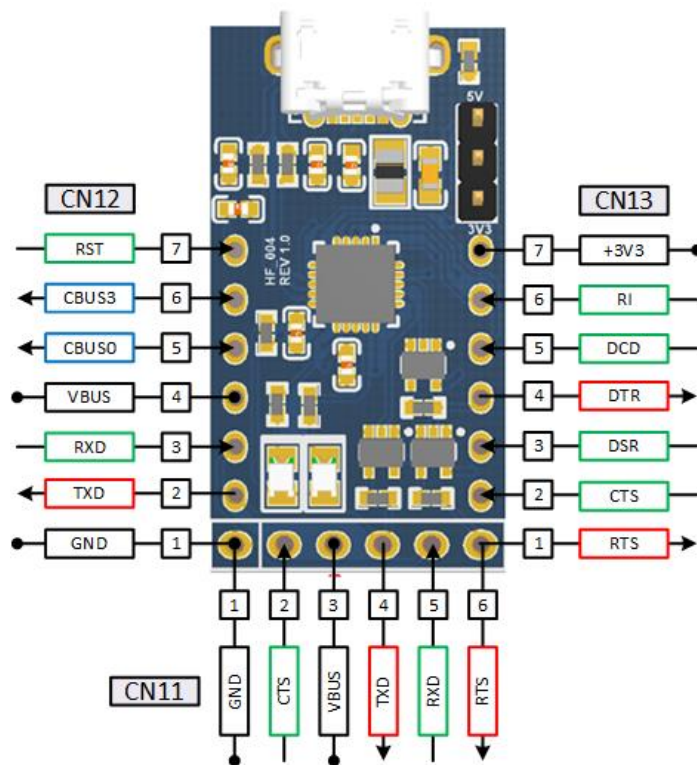

Figure 2 - Module Interface Diagram

The pin description of **CN11** is given in **Table 2**.

Pin No	Pin Name	Type	Description
1	GND	Power	Ground
2	CTS	Input	Clear To Send Control Input/Handshake signal
3	VBUS	Power	5V Supply
4	TXD	Output	Transmit Asynchronous Data Output
5	RXD	Input	Receiving Asynchronous Data Input
6	RTS	Output	Request To Send Control Output/Handshake Signal

Table 2 - CN11 Pin Description

The LC231X can support both 3.3V and 5V interfacing; the power jumper selection is through **CN14**. The default jumper setting is in 3.3V interface.

Pin Number	Description
1-2	3.3V IO interface (Default)
2-3	5V IO interface

Table 3 - CN14 Jumper Selection

If user require a simple UART interface (TX,RX,CTS and RTS),user can use **CN11** which follow standard FTDI TTL interface. If user requires UART with full modem control and some extra configurable IO port, user can consider use **CN12** and **CN13** which provide UART with full modem control and IO port. The pin description of **CN12** and **CN13** is given by **Table 4** and **Table 5**. Note the user could only fit either CN11 or CN12/CN13 connectors at the same time.

Pin No	Pin Name	Type	Description
1	GND	Power	Ground
2	TXD	Output	Transmit Asynchronous Data Output
3	RXD	Input	Receiving Asynchronous Data Input
4	VBUS	Power	5V Supply at 450mA
5	CBUS0	GPIO	Configurable IO port
6	CBUS3	GPIO	Configurable IO port
7	RST	Input	FT231X Reset

Table 4 - CN12 Pin Description

Pin No	Pin Name	Type	Description
1	RTS	Output	Request To Send Control Output/Handshake Signal
2	CTS	Input	Clear To Send Control Input/Handshake signal
3	DSR	Input	Data Set Ready Control Input/Handshake Signal
4	DTR	Output	Data Terminal Ready Control Output/Handshake Signal
5	DCD	Input	Data Carrier Detect Control Input
6	RI	Input	Ring Indicator Input for Remote Wake Up
7	3V3	Power	3V3 Supply at 50mA

Table 5 - CN13 Pin Description

5 Devices Characteristics and Ratings

5.1 Electrical Specification

Parameter	Value	Unit	Conditions
Storage Temperature	-30°C to 80°C	Degrees C	
Ambient Operating Temperature (Power Applied)	-20°C to 70°C	Degrees C	

Table 6 - Temperature Parameters

DC Characteristics (Ambient Temperature = -20°C to +70°C)

IO interface: 5V

Parameter	Description	Minimum	Typical	Maximum	Units	Conditions
V_{bus}	Output Power Voltage	4.75		5.25	V	
I_o	Supply current		450		mA	Assuming connected to direct to a host port or a powered hub, and enumerated
V_{oh}	Output Voltage High	3.2	4.1	4.9	V	
V_{ol}	Output Voltage Low	0.3	0.4	0.6	V	

Table 7 - 5V Interface Operating Voltage and Current

DC Characteristics (Ambient Temperature = -20°C to +70°C)

IO interface: 3V3

Parameter	Description	Minimum	Typical	Maximum	Units	Conditions
V_{bus}	Output Power Voltage	4.75		5.25	V	
I_o	Supply current		450		mA	Assuming connected to direct to a host port or a powered hub, and enumerated
V_{oh}	Output Voltage High	2.2	2.8	3.2	V	
V_{ol}	Output Voltage Low	0.3	0.4	0.6	V	

Table 8 - 3V3 Interface Operating Voltage and Current

6 Board Schematic

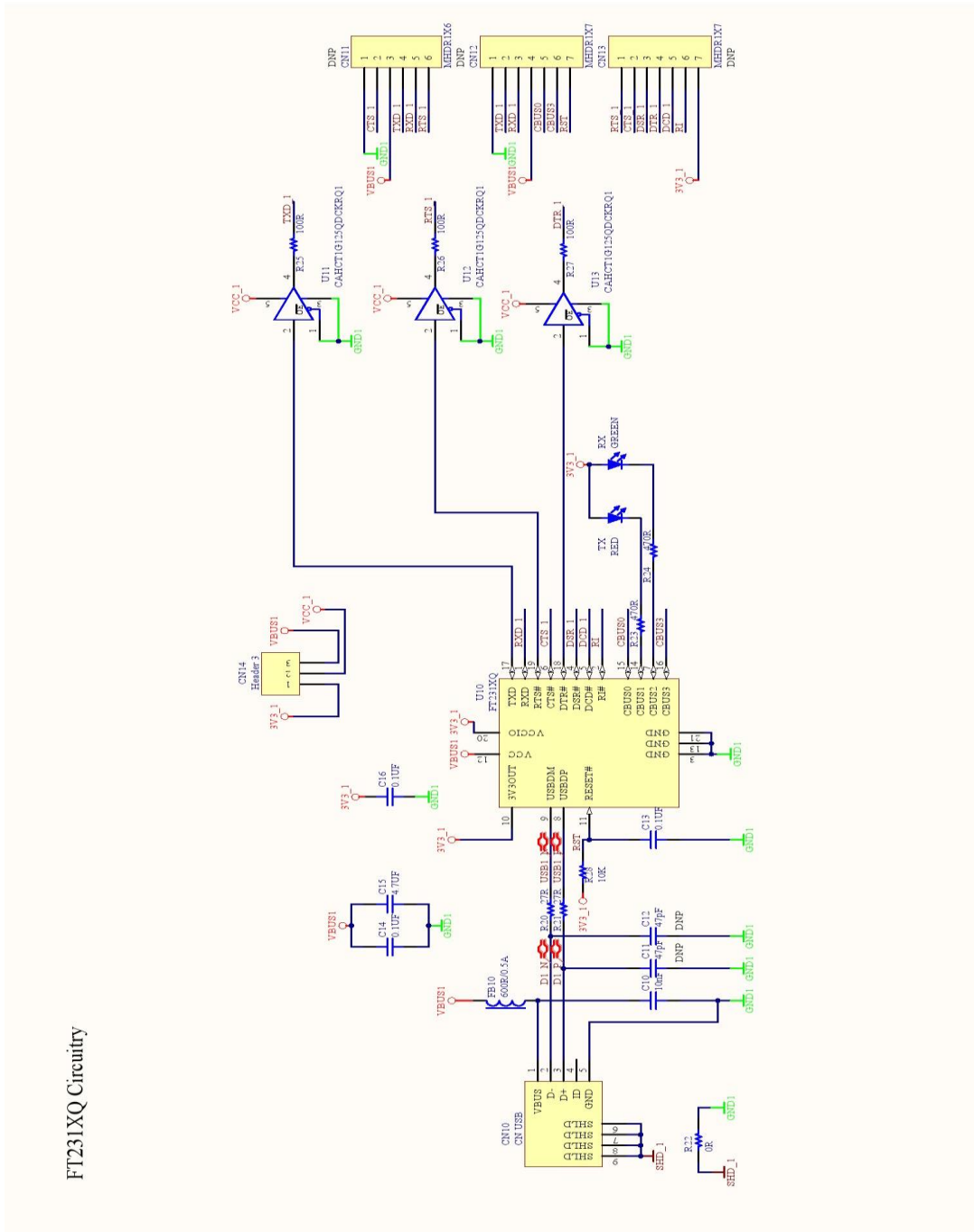

Figure 3 – FT231X Schematics

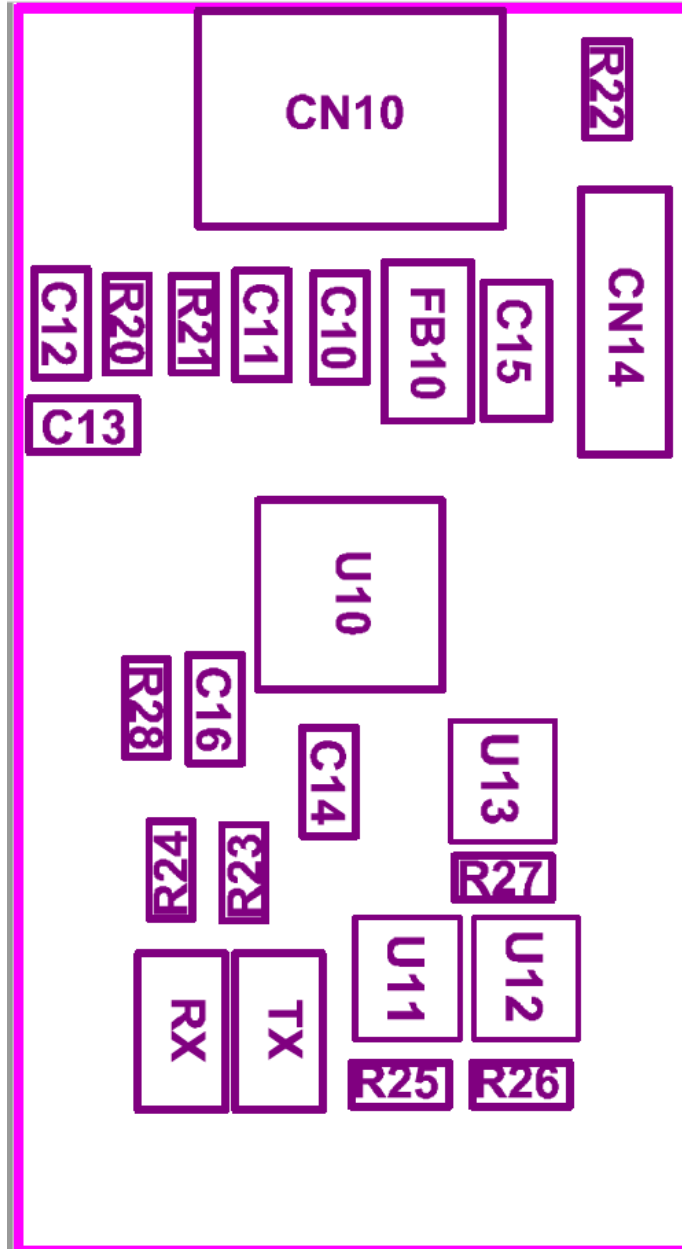

Figure 4 – LC231X Module Components Placement

7 Mechanical Dimensions

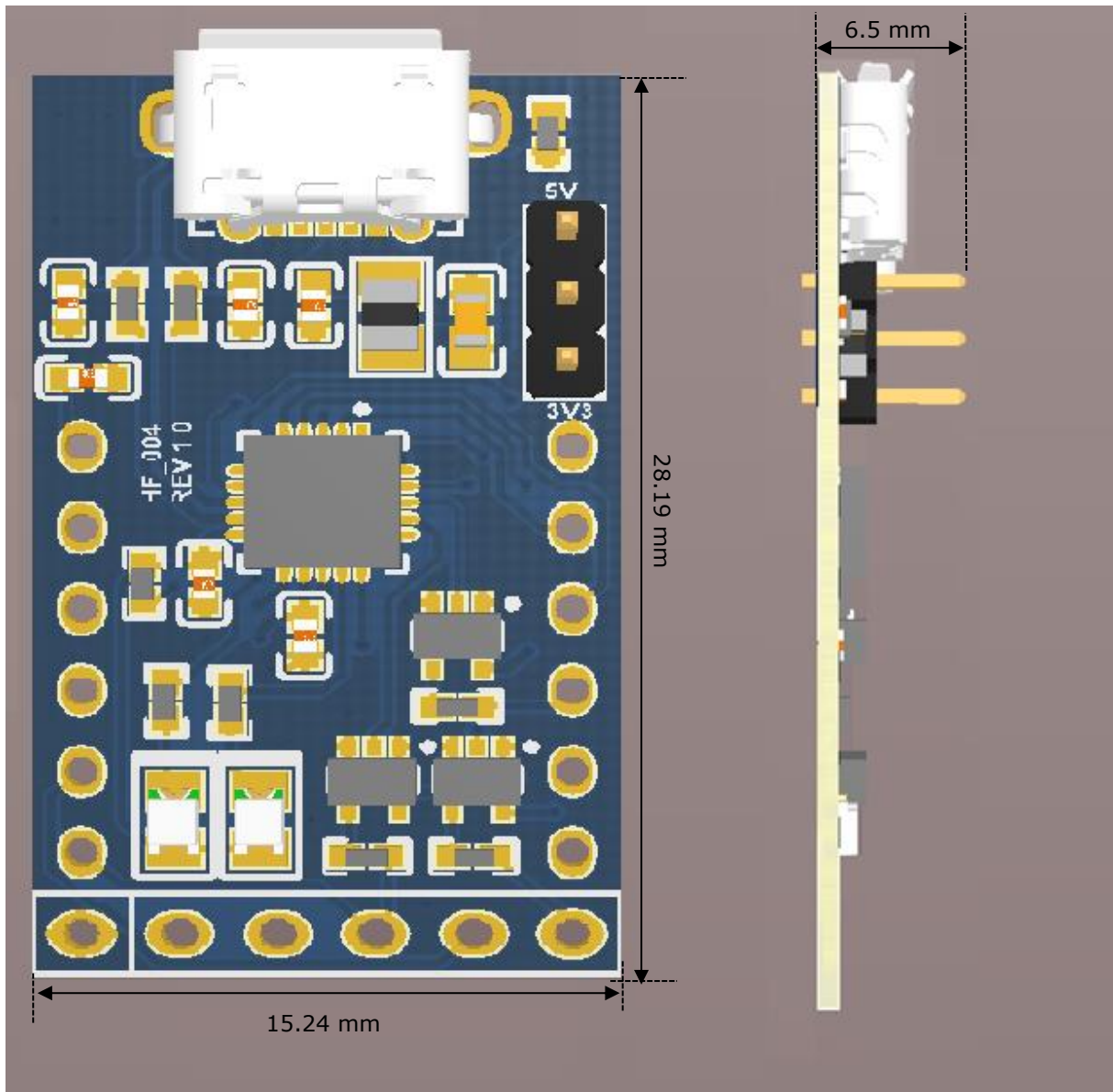

Figure 5 – LC231X Module Dimensions

8 Contact Information

Head Office – Glasgow, UK

Future Technology Devices International Limited
Unit 1, 2 Seaward Place, Centurion Business Park
Glasgow G41 1HH
United Kingdom
Tel: +44 (0) 141 429 2777
Fax: +44 (0) 141 429 2758

E-mail (Sales) sales1@ftdichip.com
E-mail (Support) support1@ftdichip.com
E-mail (General Enquiries) admin1@ftdichip.com

Branch Office – Tigard, Oregon, USA

Future Technology Devices International Limited (USA)
7130 SW Fir Loop
Tigard, OR 97223-8160
USA
Tel: +1 (503) 547 0988
Fax: +1 (503) 547 0987

E-mail (Sales) us.sales@ftdichip.com
E-mail (Support) us.support@ftdichip.com
E-mail (General Enquiries) us.admin@ftdichip.com

Branch Office – Taipei, Taiwan

Future Technology Devices International Limited (Taiwan)
2F, No. 516, Sec. 1, NeiHu Road
Taipei 114
Taiwan, R.O.C.
Tel: +886 (0) 2 8797 1330
Fax: +886 (0) 2 8751 9737

E-mail (Sales) tw.sales1@ftdichip.com
E-mail (Support) tw.support1@ftdichip.com
E-mail (General Enquiries) tw.admin1@ftdichip.com

Branch Office – Shanghai, China

Future Technology Devices International Limited (China)
Room 1103, No. 666 West Huaihai Road,
Shanghai, 200052
China
Tel: +86 21 62351596
Fax: +86 21 62351595

E-mail (Sales) cn.sales@ftdichip.com
E-mail (Support) cn.support@ftdichip.com
E-mail (General Enquiries) cn.admin@ftdichip.com

Web Site

<http://ftdichip.com>

Distributor and Sales Representatives

Please visit the Sales Network page of the [FTDI Web site](#) for the contact details of our distributor(s) and sales representative(s) in your country.

System and equipment manufacturers and designers are responsible to ensure that their systems, and any Future Technology Devices International Ltd (FTDI) devices incorporated in their systems, meet all applicable safety, regulatory and system-level performance requirements. All application-related information in this document (including application descriptions, suggested FTDI devices and other materials) is provided for reference only. While FTDI has taken care to assure it is accurate, this information is subject to customer confirmation, and FTDI disclaims all liability for system designs and for any applications assistance provided by FTDI. Use of FTDI devices in life support and/or safety applications is entirely at the user's risk, and the user agrees to defend, indemnify and hold harmless FTDI from any and all damages, claims, suits or expense resulting from such use. This document is subject to change without notice. No freedom to use patents or other intellectual property rights is implied by the publication of this document. Neither the whole nor any part of the information contained in, or the product described in this document, may be adapted or reproduced in any material or electronic form without the prior written consent of the copyright holder. Future Technology Devices International Ltd, Unit 1, 2 Seaward Place, Centurion Business Park, Glasgow G41 1HH, United Kingdom. Scotland Registered Company Number: SC136640

Appendix A – References

Document References

For module documentations, please refer to URL below:

FT231X datasheet: [FT231X Datasheet](#)

Acronyms and Abbreviations

Terms	Description
LED	Light-emitting diode
USB	Universal Serial Bus
UART	Universal Asynchronous Receiver/Transmitter

Appendix B - List of Figures and Tables

List of Tables

Table 1 - Module Features & Description.....	4
Table 2 - CN11 Pin Description.....	5
Table 3 - CN14 Jumper Selection.....	6
Table 4 - CN12 Pin Description.....	6
Table 5 - CN13 Pin Description.....	6
Table 6 - Temperature Parameters	7
Table 7 - 5V Interface Operating Voltage and Current	7
Table 8 - 3V3 Interface Operating Voltage and Current	7

List of Figures

Figure 1 - Module Features	4
Figure 2 - Module Interface Diagram.....	5
Figure 3 - FT231X Schematics	8
Figure 4 - LC231X Module Components Placement	9
Figure 5 - LC231X Module Dimensions.....	10

Appendix C – Revision History

Document Title: LC231X Module Datasheet
Document Reference No.: FT_001388
Clearance No.: FTDI#516
Product Page: <http://www.ftdichip.com/LC231X.htm>
Document Feedback: [Send Feedback](#)

Revision	Changes	Date
Version 1.0	Initial Release	2017-02-21
Version 1.1	Updated release	2017-03-30

X-ON Electronics

Largest Supplier of Electrical and Electronic Components

Click to view similar products for [Interface Development Tools](#) category:

Click to view products by [FTDI](#) manufacturer:

Other Similar products are found below :

[ADP5585CP-EVALZ](#) [CHA2066-99F](#) [AS8650-DB](#) [416100120-3](#) [XR18910ILEVB](#) [XR21B1421IL28-0A-EVB](#) [EVAL-ADM2491EEBZ](#)
[MAXREFDES23DB#](#) [MAX13235EEVKIT](#) [DFR0257](#) [XR22404CG28EVB](#) [ZLR964122L](#) [ZLR88822L](#) [DC327A](#) [PIM511](#) [PIM536](#) [PIM517](#)
[DEV-17512](#) [STR-FUSB3307MPX-PPS-GEVK](#) [ZSSC3240KIT](#) [P0551](#) [MAX9121EVKIT](#) [PIM532](#) [ZSC31010KITV2P1](#) [UMFT4233HPEV](#)
[MIKROE-2335](#) [XR20M1172G28-0B-EB](#) [SI871XSOIC8-KIT](#) [1764](#) [1833](#) [1862](#) [EVB-USB82514](#) [ATA6628-EK](#) [EVAL-CN0313-SDPZ](#) [2264](#)
[MCP23X17EV](#) [PS081-EVA-HR MODULE](#) [237](#) [SMA2RJ45EVK/NOPB](#) [FR12-0002](#) [MAFR-000455-001](#) [BOB-13263](#) [ORG4572-R01-UAR](#)
[CPC5622-EVAL-600R](#) [SKYFR-000743](#) [SKYFR-000827](#) [SKYFR-000982](#) [MIKROE-2750](#) [292](#) [DFR0065](#)