

# Future Technology Devices International Limited

## Datasheet

### LC234X Development Module

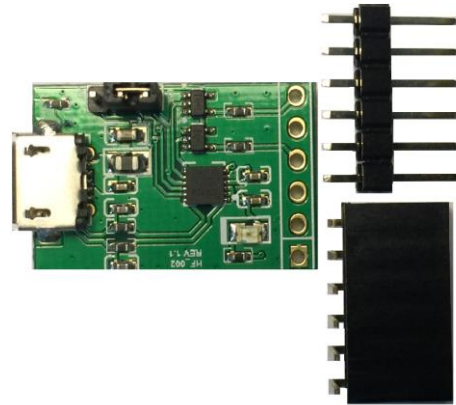

## 1 Introduction

The LC234X module is a low cost USB to UART bridge using the FTDI FT234XD to transfer data at up to 3M Baud. Ideal for programming Arduino Pro, ESP modules etc., the pinout follows the industry standard FTDI TTL cable interface. In addition to the 4 data lines (RXD, TXD, RTS, CTS) there is also the option to output 5V power to external hardware. The interface IO level may be set to either 3.3V or 5V by an on-board jumper – no soldering / de-soldering required.

The LC234X module's UART interface is mapped to one 1X6 pin header. The module is supplied with one right angle socket and one right angle pin header for maximum flexibility.

Furthermore there is an LED provided to indicate data transmission on the UART signals

## 1.1 Features

The LC234X module utilises the FT234XD from FTDI. For a full list of the FT234XD's features refer to the [FT234XD datasheet](#).

In addition, the LC234X module has the following features:

- Small PCB size as 15.24mm X 22.89mm
- Easy configurable IO voltage interface
- USB 2.0 full speed
- Low supply current: 10mA
- Supported baud rates: 300 bps to 3 Mbps
- Supplied with one right angle socket and one right angle pin header for maximum flexibility.
- Power output to external logic 5V
- -40°C to +85°C operational temperature range
- Full RoHS compliance

Neither the whole nor any part of the information contained in, or the product described in this manual, may be adapted or reproduced in any material or electronic form without the prior written consent of the copyright holder. This product and its documentation are supplied on an as-is basis and no warranty as to their suitability for any particular purpose is either made or implied. Future Technology Devices International Ltd will not accept any claim for damages howsoever arising as a result of use or failure of this product. Your statutory rights are not affected. This product or any variant of it is not intended for use in any medical appliance, device or system in which the failure of the product might reasonably be expected to result in personal injury. This document provides preliminary information that may be subject to change without notice. No freedom to use patents or other intellectual property rights is implied by the publication of this document. Future Technology Devices International Ltd, Unit 1, 2 Seaward Place, Centurion Business Park, Glasgow G41 1HH United Kingdom. Scotland Registered Company Number: SC136640

## 2 Typical Applications

- USB to UART bridge
- Debugger / Programmer for embedded MCU e.g. Arduino
- USB IO extender for small 8-bit micro's

### 2.1 Driver Support

The LC234X requires USB drivers (listed below), available free from <http://www.ftdichip.com>, which are used to make the module appear as a virtual COM port (VCP). This allows the user to communicate with the USB interface via a standard PC serial emulation port (for example TTY). Another FTDI USB driver, the D2XX driver, can also be used with application software to directly access the LC234X through a DLL. Both VCP and D2XX drivers support Windows auto-update.

#### **Royalty free VIRTUAL COM PORT (VCP) DRIVERS for...**

- Windows 10 32,64-bit
- Windows 8/8.1 32,64-bit
- Windows 7 32,64-bit
- Windows CE 4.2, 5.0 and 6.0
- Windows Server 2003, 2008 R2, 2012
- Mac OS-X
- Linux 2.4 and greater

#### **Royalty free D2XX Direct Drivers (USB Drivers + DLL S/W Interface)**

- Windows 10 32,64-bit
- Windows 8/8.1 32,64-bit
- Windows 7 32,64-bit
- Windows CE 4.2, 5.0 and 6.0
- Windows Server 2003, 2008 R2, 2012
- MAC OS-X
- Linux 2.4 and greater
- Android(J2xx)

For driver installation, please refer to the installation guides on our website:

<http://www.ftdichip.com/Support/Documents/InstallGuides.htm>

## 3 Ordering Information

<b>Part No.</b>	<b>Description</b>
LC234X	Low cost FT234X USB to UART module

---

## **Table of Contents**

<b>1</b>	<b>Introduction .....</b>	<b>1</b>
1.1	Features.....	1
<b>2</b>	<b>Typical Applications .....</b>	<b>2</b>
2.1	Driver Support .....	2
<b>3</b>	<b>Ordering Information .....</b>	<b>2</b>
<b>4</b>	<b>Pin Out and Signal Description .....</b>	<b>4</b>
4.1	Module Description .....	4
4.2	Module Interface Signal Description .....	5
<b>5</b>	<b>Devices Characteristics and Ratings.....</b>	<b>6</b>
5.1	Electrical Specification .....	6
<b>6</b>	<b>Board Schematic .....</b>	<b>7</b>
<b>7</b>	<b>Mechanical Dimensions .....</b>	<b>9</b>
<b>8</b>	<b>Contact Information.....</b>	<b>10</b>
<b>Appendix A – References .....</b>		<b>11</b>
Document References .....		11
Acronyms and Abbreviations .....		11
<b>Appendix B - List of Figures and Tables .....</b>		<b>12</b>
List of Tables.....		12
List of Figures .....		12
<b>Appendix C – Revision History .....</b>		<b>13</b>

## 4 Pin Out and Signal Description

### 4.1 Module Description

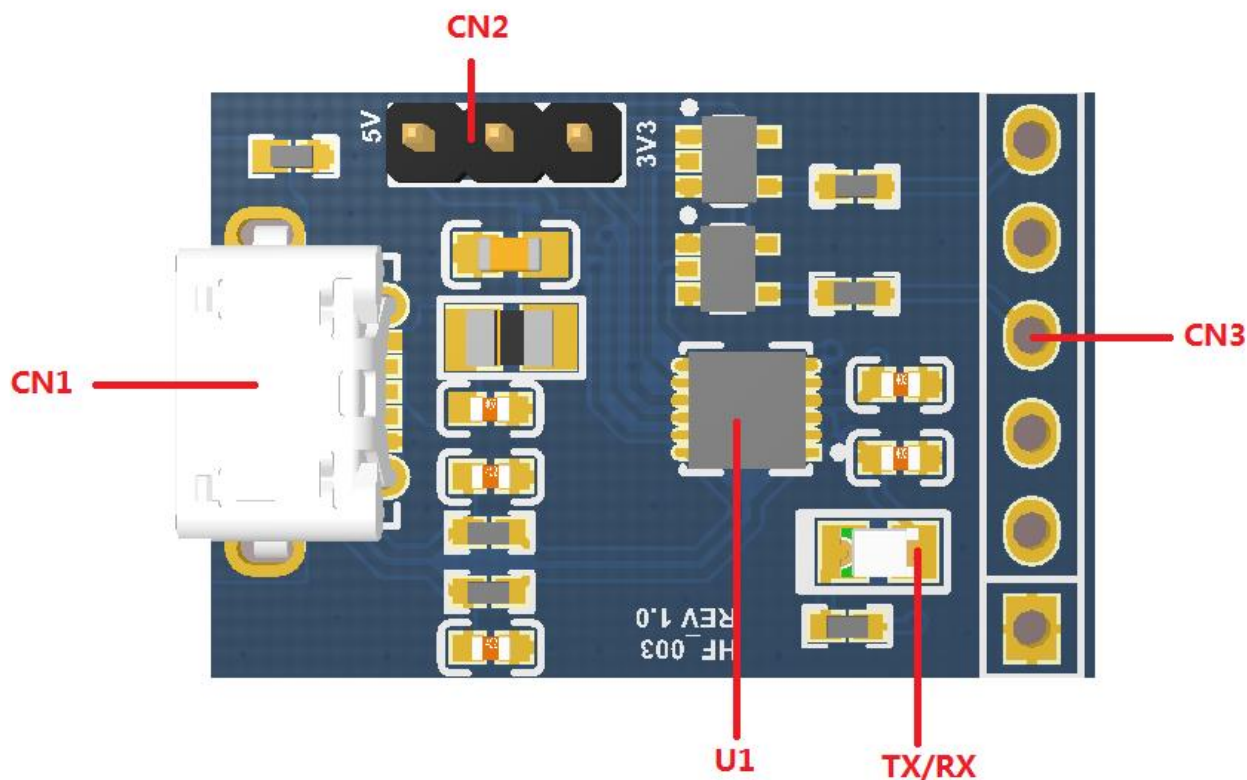

Figure 1 - Module Features

Feature	Reference Designator
Micro USB connector	CN1
IO voltage selection	CN2
6pin 2.54mm pitch connector UART interface	CN3
FT234X USB to serial bridge IC	U1
Green color LED	TX/RX

Table 1 - Module Features & Description

## 4.2 Module Interface Signal Description

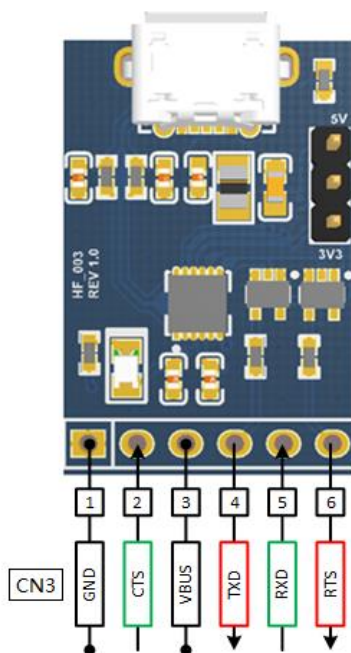

Figure 2 - Module Signal Diagram

The pin description of **CN3** is given in **Table 2**.

Pin No	Pin Name	Type	Description
1	GND	Power	Ground
2	CTS	Input	Clear To Send Control Input/Handshake
3	VBUS	Power	5V Supply
4	TXD	Output	Transmit Asynchronous Data Output
5	RXD	Input	Receiving Asynchronous Data Input
6	RTS	Output	Request To Send Control Output/Handshake Signal

Table 2 – CN3 Pin Description

The LC234X can support both 3.3V and 5V interface, the power jumper selection is through **CN2**. The default jumper setting is in 3.3V interface

Pin Number	Description
1-2	3.3V IO interface (Default)
2-3	5V IO interface

Table 3 – CN2 Jumper Selection

## 5 Devices Characteristics and Ratings

### 5.1 Electrical Specification

Parameter	Value	Unit	Conditions
Storage Temperature	-30°C to 80°C	Degrees C	
Ambient Operating Temperature (Power Applied)	-20°C to 70°C	Degrees C	

**Table 4 – Temperature Parameters**

DC Characteristics (Ambient Temperature = -20°C to +70°C)

IO interface: 5V

Parameter	Description	Minimum	Typical	Maximum	Units	Conditions
$V_{bus}$	Output Power Voltage	4.75		5.25	V	
$I_o$	Supply current		450		mA	Assuming connected to direct to a host port or a powered hub, and enumerated
$V_{oh}$	Output Voltage High	3.2	4.1	4.9	V	
$V_{ol}$	Output Voltage Low	0.3	0.4	0.6	V	

**Table 5 – 5V Interface Operating Voltage and Current**

DC Characteristics (Ambient Temperature = -20°C to +70°C)

IO interface: 3V3

Parameter	Description	Minimum	Typical	Maximum	Units	Conditions
$V_{bus}$	Output Power Voltage	4.75		5.25	V	
$I_o$	Supply current		450		mA	Assuming connected to direct to a host port or a powered hub, and enumerated
$V_{oh}$	Output Voltage High	2.2	2.8	3.2	V	
$V_{ol}$	Output Voltage Low	0.3	0.4	0.6	V	

**Table 6 – 3V3 Interface Operating Voltage and Current**

## 6 Board Schematic

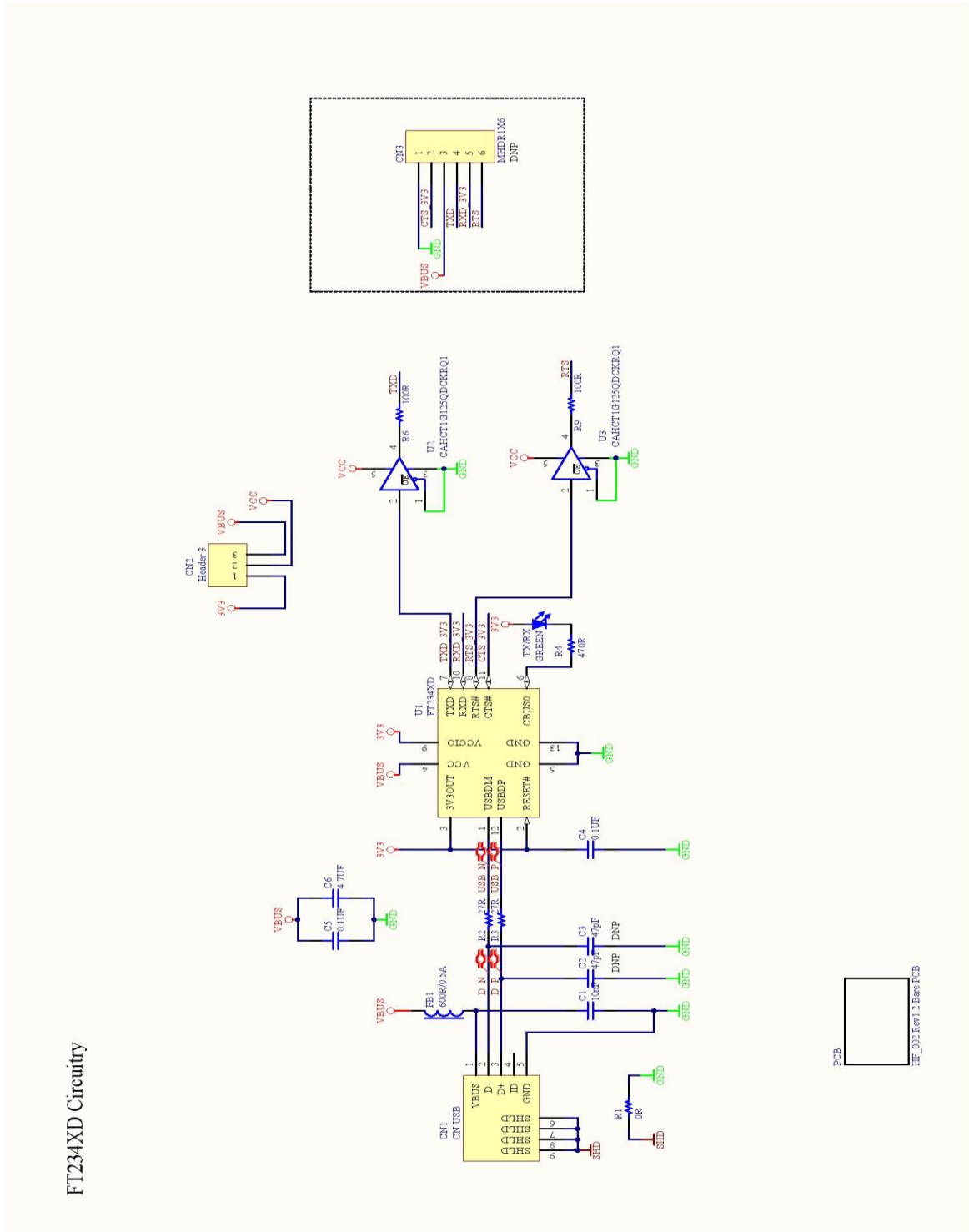
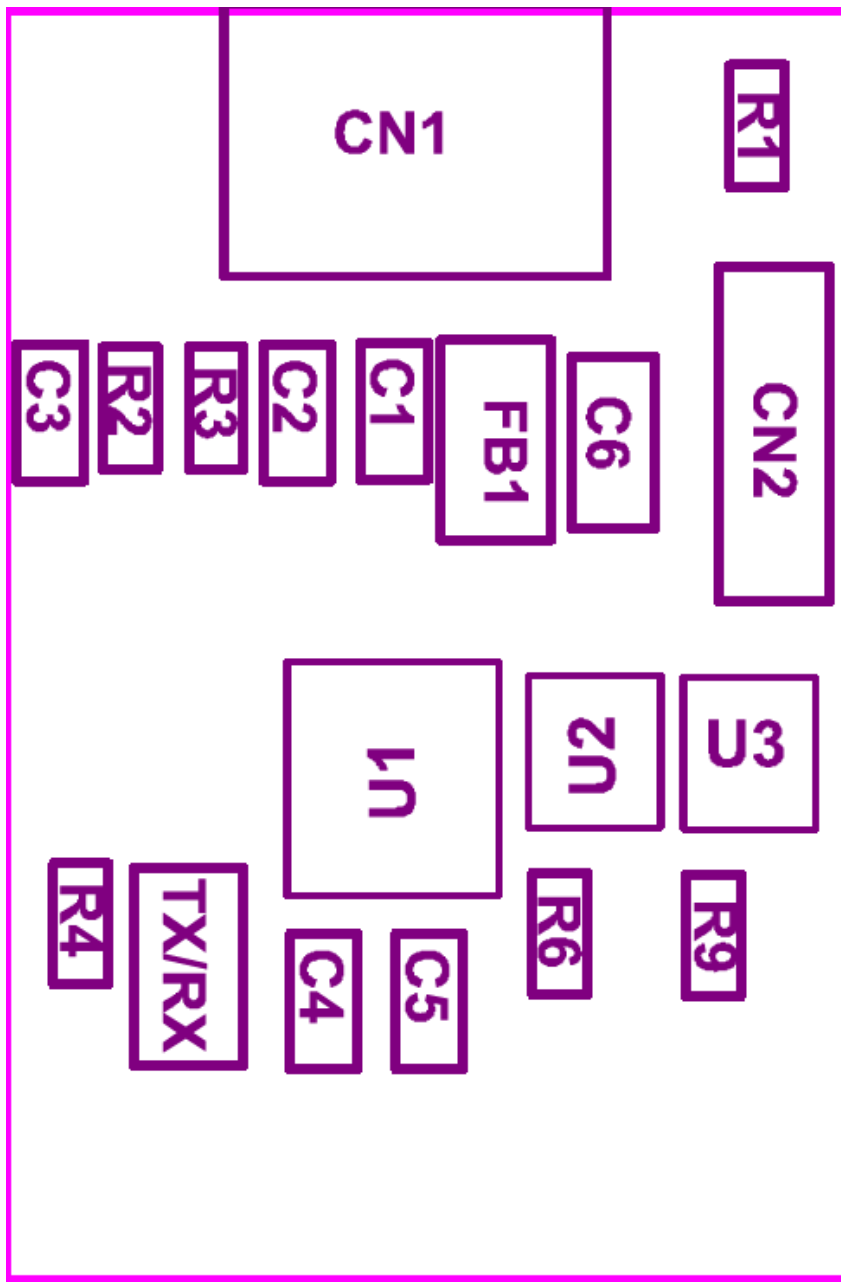

Figure 3 - FT234X Schematics



**Figure 4 - LC234X Module Component Placement**



## 7 Mechanical Dimensions

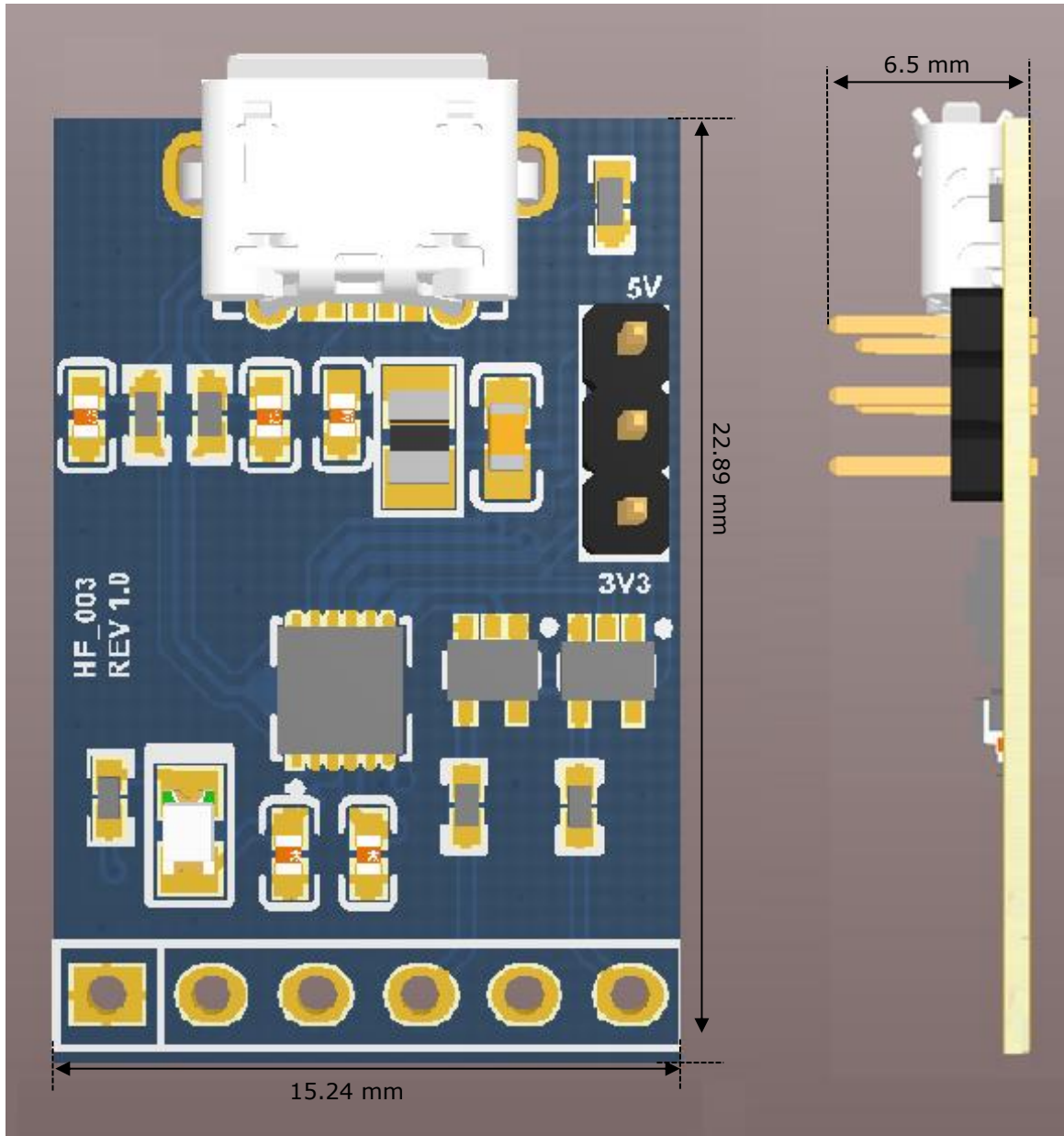

**Figure 5 - LC234X Module Dimensions**

## 8 Contact Information

### Head Office – Glasgow, UK

Future Technology Devices International Limited  
Unit 1, 2 Seaward Place, Centurion Business Park  
Glasgow G41 1HH  
United Kingdom  
Tel: +44 (0) 141 429 2777  
Fax: +44 (0) 141 429 2758

E-mail (Sales) [sales1@ftdichip.com](mailto:sales1@ftdichip.com)  
E-mail (Support) [support1@ftdichip.com](mailto:support1@ftdichip.com)  
E-mail (General Enquiries) [admin1@ftdichip.com](mailto:admin1@ftdichip.com)

### Branch Office – Tigard, Oregon, USA

Future Technology Devices International Limited (USA)  
7130 SW Fir Loop  
Tigard, OR 97223-8160  
USA  
Tel: +1 (503) 547 0988  
Fax: +1 (503) 547 0987

E-mail (Sales) [us.sales@ftdichip.com](mailto:us.sales@ftdichip.com)  
E-mail (Support) [us.support@ftdichip.com](mailto:us.support@ftdichip.com)  
E-mail (General Enquiries) [us.admin@ftdichip.com](mailto:us.admin@ftdichip.com)

### Branch Office – Taipei, Taiwan

Future Technology Devices International Limited (Taiwan)  
2F, No. 516, Sec. 1, NeiHu Road  
Taipei 114  
Taiwan, R.O.C.  
Tel: +886 (0) 2 8797 1330  
Fax: +886 (0) 2 8751 9737

E-mail (Sales) [tw.sales1@ftdichip.com](mailto:tw.sales1@ftdichip.com)  
E-mail (Support) [tw.support1@ftdichip.com](mailto:tw.support1@ftdichip.com)  
E-mail (General Enquiries) [tw.admin1@ftdichip.com](mailto:tw.admin1@ftdichip.com)

### Branch Office – Shanghai, China

Future Technology Devices International Limited (China)  
Room 1103, No. 666 West Huaihai Road,  
Shanghai, 200052  
China  
Tel: +86 21 62351596  
Fax: +86 21 62351595

E-mail (Sales) [cn.sales@ftdichip.com](mailto:cn.sales@ftdichip.com)  
E-mail (Support) [cn.support@ftdichip.com](mailto:cn.support@ftdichip.com)  
E-mail (General Enquiries) [cn.admin@ftdichip.com](mailto:cn.admin@ftdichip.com)

### Web Site

<http://ftdichip.com>

### Distributor and Sales Representatives

Please visit the Sales Network page of the [FTDI Web site](#) for the contact details of our distributor(s) and sales representative(s) in your country.

System and equipment manufacturers and designers are responsible to ensure that their systems, and any Future Technology Devices International Ltd (FTDI) devices incorporated in their systems, meet all applicable safety, regulatory and system-level performance requirements. All application-related information in this document (including application descriptions, suggested FTDI devices and other materials) is provided for reference only. While FTDI has taken care to assure it is accurate, this information is subject to customer confirmation, and FTDI disclaims all liability for system designs and for any applications assistance provided by FTDI. Use of FTDI devices in life support and/or safety applications is entirely at the user's risk, and the user agrees to defend, indemnify and hold harmless FTDI from any and all damages, claims, suits or expense resulting from such use. This document is subject to change without notice. No freedom to use patents or other intellectual property rights is implied by the publication of this document. Neither the whole nor any part of the information contained in, or the product described in this document, may be adapted or reproduced in any material or electronic form without the prior written consent of the copyright holder. Future Technology Devices International Ltd, Unit 1, 2 Seaward Place, Centurion Business Park, Glasgow G41 1HH, United Kingdom. Scotland Registered Company Number: SC136640

## Appendix A – References

### Document References

For module documentations, please refer to URL below:

FT234XD datasheet: [FT234XD Datasheet](#)

### Acronyms and Abbreviations

Terms	Description
LED	Light-emitting diode
UART	Universal Asynchronous Receiver/Transmitter
USB	Universal Serial Bus

---

## **Appendix B - List of Figures and Tables**

### **List of Tables**

Table 1 - Module Features & Description.....	4
Table 2 – CN3 Pin Description .....	5
Table 3 – CN2 Jumper Selection .....	5
Table 4 – Temperature Parameters.....	6
Table 5 – 5V Interface Operating Voltage and Current.....	6
Table 6 – 3V3 Interface Operating Voltage and Current.....	6

### **List of Figures**

Figure 1 - Module Features .....	4
Figure 2 - Module Signal Diagram.....	5
Figure 3 - FT234X Schematics.....	7
Figure 4 - LC234X Module Component Placement .....	8
Figure 5 - LC234X Module Dimensions .....	9

## Appendix C – Revision History

Document Title: LC234X Module Datasheet  
Document Reference No.: FT\_001387  
Clearance No.: FTDI#517  
Product Page: <http://www.ftdichip.com/LC234X.htm>  
Document Feedback: [Send Feedback](#)

Revision	Changes	Date
Version 1.0	Initial release	2017-02-21
Version 1.1	Updated release	2017-03-30

## X-ON Electronics

Largest Supplier of Electrical and Electronic Components

*Click to view similar products for [Interface Development Tools](#) category:*

*Click to view products by [FTDI](#) manufacturer:*

Other Similar products are found below :

[ADP5585CP-EVALZ](#) [CHA2066-99F](#) [AS8650-DB](#) [416100120-3](#) [XR18910ILEVB](#) [XR21B1421IL28-0A-EVB](#) [EVAL-ADM2491EEBZ](#)  
[MAXREFDES23DB#](#) [MAX13235EEVKIT](#) [DFR0257](#) [XR22404CG28EVB](#) [ZLR964122L](#) [ZLR88822L](#) [DC327A](#) [PIM511](#) [PIM536](#) [PIM517](#)  
[DEV-17512](#) [STR-FUSB3307MPX-PPS-GEVK](#) [ZSSC3240KIT](#) [P0551](#) [MAX9121EVKIT](#) [PIM532](#) [ZSC31010KITV2P1](#) [UMFT4233HPEV](#)  
[MIKROE-2335](#) [XR20M1172G28-0B-EB](#) [SI871XSOIC8-KIT](#) [1764](#) [1833](#) [1862](#) [EVB-USB82514](#) [ATA6628-EK](#) [EVAL-CN0313-SDPZ](#) [2264](#)  
[MCP23X17EV](#) [PS081-EVA-HR MODULE](#) [237](#) [SMA2RJ45EVK/NOPB](#) [FR12-0002](#) [MAFR-000455-001](#) [BOB-13263](#) [ORG4572-R01-UAR](#)  
[CPC5622-EVAL-600R](#) [SKYFR-000743](#) [SKYFR-000827](#) [SKYFR-000982](#) [MIKROE-2750](#) [292](#) [DFR0065](#)