

FTDI Chip

UMFT4222PROG-IC

FT4222

Programmer Module



1 Introduction

The UMFT4222PROG-IC Programmer Module has been developed to aid programming OTP memory in the FT4222H.

The internal OTP memory in the FT4222H is used to store USB Vendor ID (VID), Product ID (PID), device serial number, product description string and various other USB configuration descriptors.

The UMFT4222PROG-IC Programmer Module is designed with the FTDI FT51. The FT51 downstream USB port is connected to the FT4222H programming socket.

The user places the FT4222H DUT in the socket, starts the programming application on the host PC which controls the main power and the OTP program power to the FT4222H. When the FT4222H is programmed and verified, the application turns off the main power and OTP programming power for safe removal of the FT4222H from the socket.

1.1 Features

- USB2.0 Full Speed compatible,
- Standard USB MicroB receptacle.
- Single USB power input, built-in DC-DC converter for 6.5 V OTP programming power and main operation power supply.
- Quick and easy F4222H OTP data production programming – drop in the FT4222H IC to be programmed, the application controls the power supplies, programming and power off automatically.
- Visual indicator for 6.5V programming voltage and USB bus power using LEDs

Neither the whole nor any part of the information contained in, or the product described in this manual, may be adapted or reproduced in any material or electronic form without the prior written consent of the copyright holder. This product and its documentation are supplied on an as-is basis and no warranty as to their suitability for any particular purpose is either made or implied. Future Technology Devices International Ltd will not accept any claim for damages howsoever arising as a result of use or failure of this product. Your statutory rights are not affected. This product or any variant of it is not intended for use in any medical appliance, device or system in which the failure of the product might reasonably be expected to result in personal injury. This document provides preliminary information that may be subject to change without notice. No freedom to use patents or other intellectual property rights is implied by the publication of this document. Future Technology Devices International Ltd, Unit 1, 2 Seaward Place, Centurion Business Park, Glasgow G41 1HH United Kingdom. Scotland Registered Company Number: SC136640

2 Module Information

2.1 Driver Support

- Microsoft Windows 10 and 10 - 64-bit
- Microsoft Windows 8.1 and 8.1 - 64-bit
- Microsoft Windows 8 and 8 - 64-bit
- Microsoft Windows 7 and Windows 7 64-bit

The drivers listed above are all available to download for free from:
<http://www.ftdichip.com/Drivers/D2XX.htm>

2.2 Ordering Information

The following **Error! Not a valid bookmark self-reference.** gives details of the available UMFT4222PROG-IC products

Part Number	Description
UMFT4222PROG-IC-B	FT4222H OTP memory programming module rev B

Table 2-1 UMFT4222 Product Descriptions and Part Numbers

Table of Contents

1	Introduction	1
1.1	Features	1
2	Module Information	2
2.1	Driver Support	2
2.2	Ordering Information	2
3	Function Description	4
3.1	Connection with UMFT4222PROG-IC.....	5
3.2	LED Indicators	5
4	UMFT4222PROG-IC module connection and Mechanical Details	6
5	Module PCB Circuit Schematic	7
6	Contact Information	10
	Appendix A – References	11
	Document References	11
	Acronyms and Abbreviations.....	11
	Appendix B –List of Figures and Tables.....	12
	List of Figures	12
	List of Tables.....	12
	Appendix C - Revision History	13

3 Function Description

The UMFT4222 Programmer IC Module (UMFT4222PROG-IC) is designed for production programming the FT4222H OTP memory. This module is designed with the FTDI FT51 chip. The FT51 built-in hub downstream port connects the FT4222H DUT to the host PC, while the FT51 built-in USB function manages the functional and OTP programming power (VPP) supplies to the FT4222H socket.

The operation to program the FT4222H with UMFT4222PROG-IC is as follows:

- Connect the module to the host PC - the UMFT4222H-IC is in standby mode and the power switch is turned off.
- Place a FT4222H DUT in the socket
- Close the socket cover.
- Run the free FTDI programming utility, FT_PROG, to update the FT4222H OTP data.

When FT_PROG finished the FT4222H OTP programming, the switch power should be turned off and restart a new IC programming.

For more details about FT_PROG, please refer to the utilities section of the [FTDI website](#).

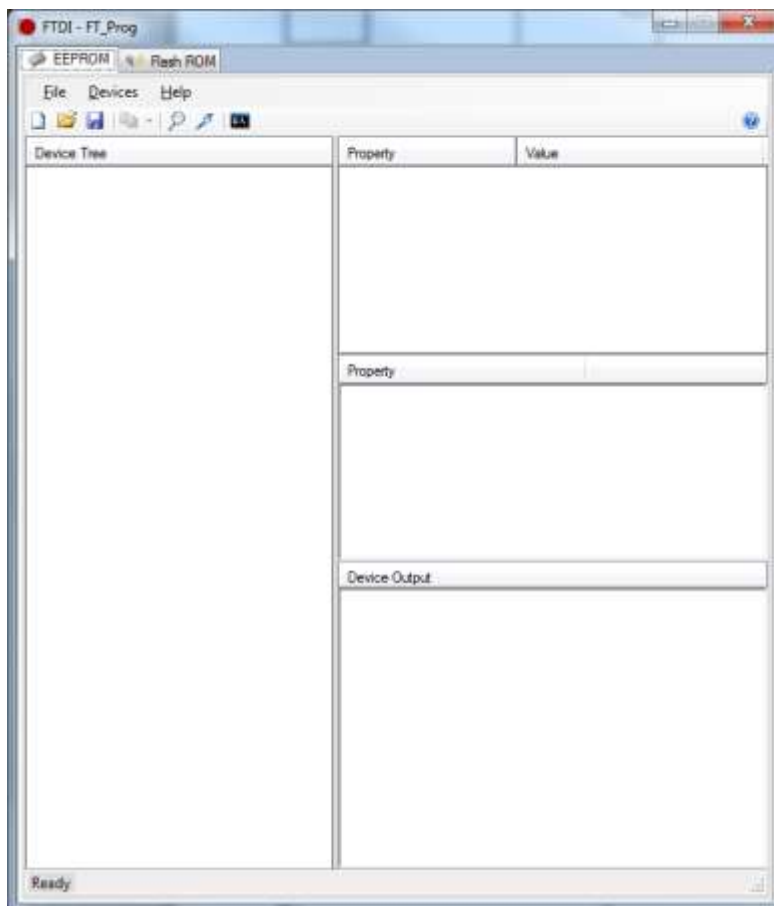

Figure 3-1 UMFT4222PROG-IC connection example

3.1 Connection with UMFT4222PROG-IC

The FT4222H supports +5V to +3.3V output from an integrated LDO regulator.

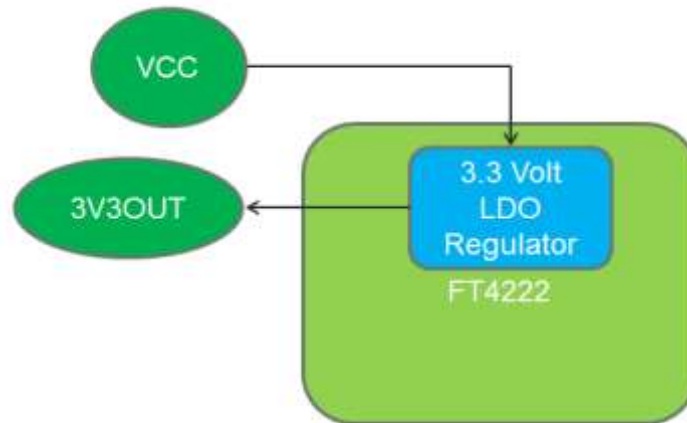

Figure 3-2 Example Function block of FT4222H integrated LDO regulator

3.2 LED Indicators

The UMFT4222PROG-IC programmer has 1 LED. Table 3.1 describes the function of the LEDs.

LED NAME	Color	LED OFF	LED ON
D2	Red	No indication	Burn in user data to FT4222 OTP block.

Table 3-1 UMFT4222PROG-IC LED Indication

4 UMFT4222PROG-IC module connection and Mechanical Details

The following

Figure 4-1 UMFT4222PROG-IC module **layout** shows the UMFT4222PROG-IC module layout. The module dimensions are 76.42mm x 44.48mm.

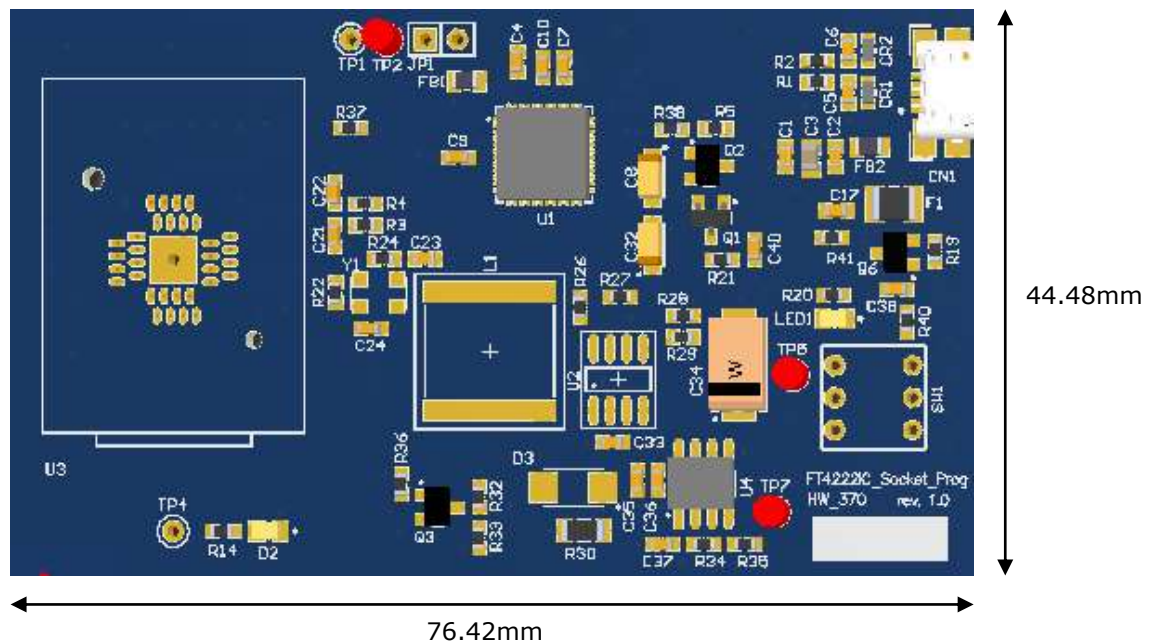

Figure 4-1 UMFT4222PROG-IC module layout

The following Table 4-1 UMFT4222PROG shows the module signals for these signals on the UMFT4222PROG-IC module.

Pin No.	Name	Type	Description
SW1	VBUS	PWR	Control U3 Main Power
TP5	DP_VBUS	PWR	Support U3 Main Power
TP1,TP7	GND	PWR	Ground
TP4	VPP	PWR	6.5V Voltage supply

Table 4-1 UMFT4222PROG module Connections (numbers refer to pad numbers on the PCB)

5 Module PCB Circuit Schematic

The circuit schematics for the small electronic board, utilising the FTDI FT51, are shown in **Error! Reference source not found.**

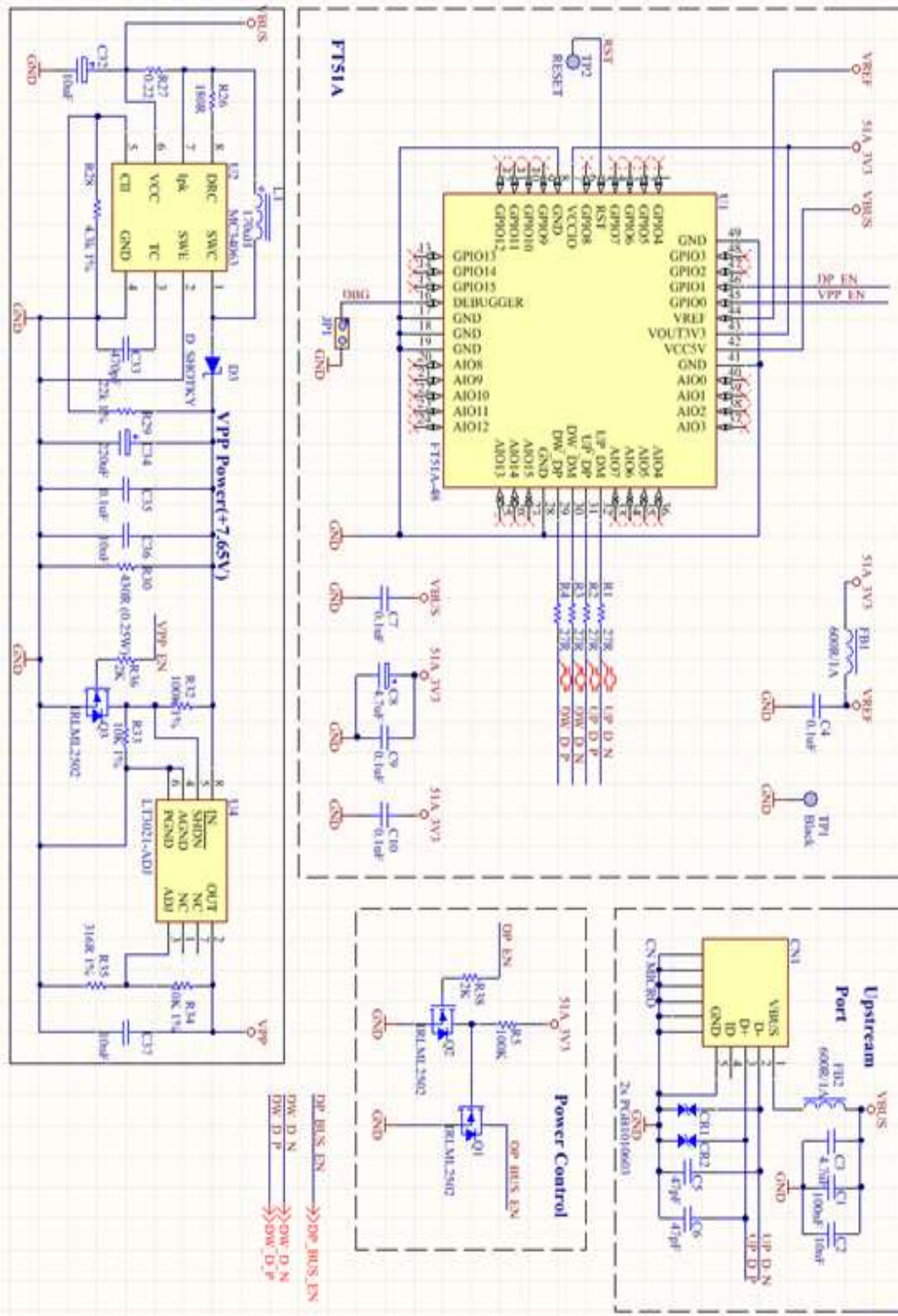
Figure 5-1 Circuit Schematic of UMFT4222PROG-IC

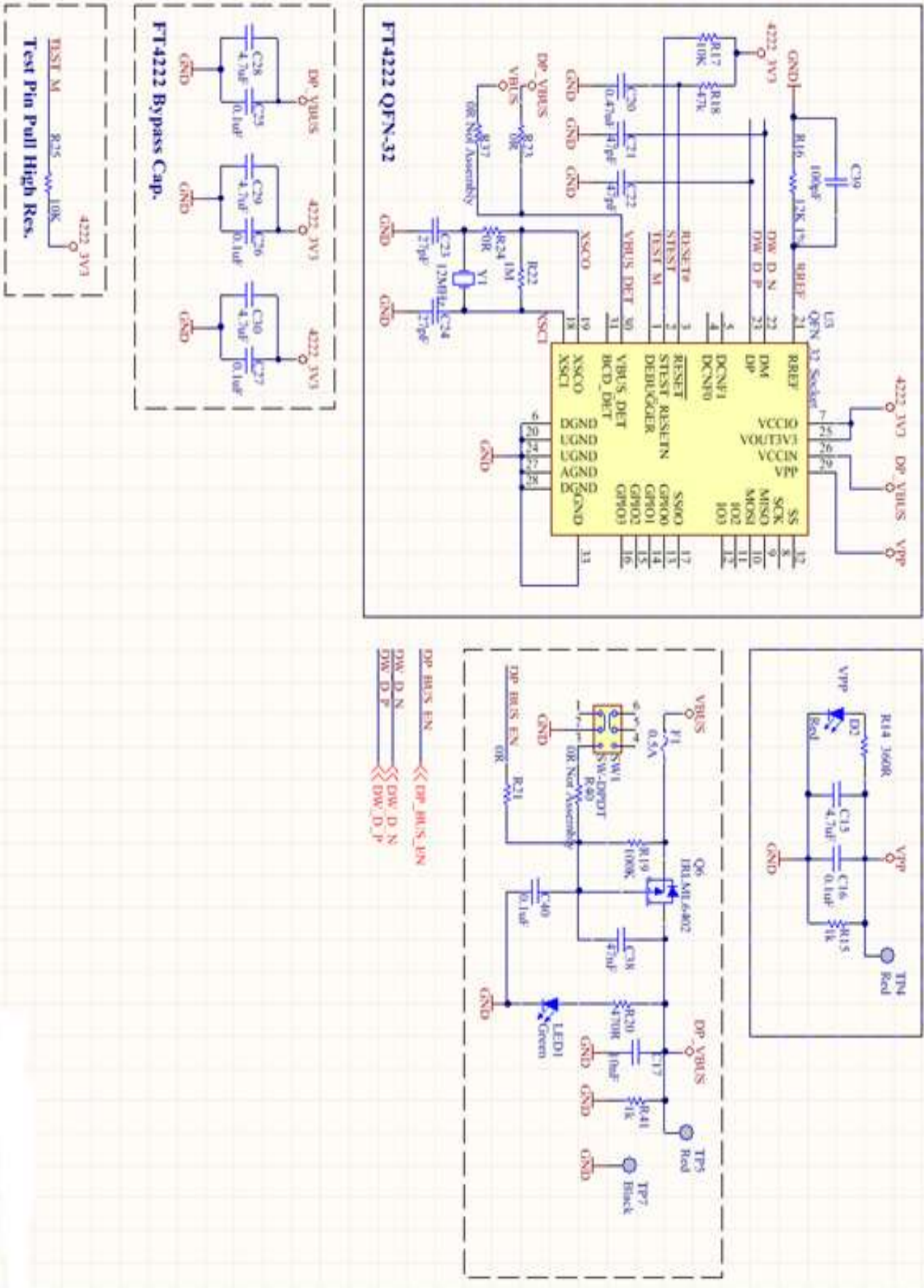
Figure 5-2 Circuit Schematic of UMFT4222PROG-IC

6 Contact Information

Head Office – Glasgow, UK

Future Technology Devices International Limited
Unit 1, 2 Seaward Place, Centurion Business Park
Glasgow G41 1HH
United Kingdom
Tel: +44 (0) 141 429 2777
Fax: +44 (0) 141 429 2758

E-mail (Sales) sales1@ftdichip.com
E-mail (Support) support1@ftdichip.com
E-mail (General Enquiries) admin1@ftdichip.com

Branch Office – Tigard, Oregon, USA

Future Technology Devices International Limited (USA)
7130 SW Fir Loop
Tigard, OR 97223-8160
USA
Tel: +1 (503) 547 0988
Fax: +1 (503) 547 0987

E-mail (Sales) us.sales@ftdichip.com
E-mail (Support) us.support@ftdichip.com
E-mail (General Enquiries) us.admin@ftdichip.com

Branch Office – Taipei, Taiwan

Future Technology Devices International Limited (Taiwan)
2F, No. 516, Sec. 1, NeiHu Road
Taipei 114
Taiwan, R.O.C.
Tel: +886 (0) 2 8797 1330
Fax: +886 (0) 2 8791 3576

E-mail (Sales) tw.sales1@ftdichip.com
E-mail (Support) tw.support1@ftdichip.com
E-mail (General Enquiries) tw.admin1@ftdichip.com

Branch Office – Shanghai, China

Future Technology Devices International Limited (China)
Room 1103, No. 666 West Huaihai Road,
Shanghai, 200052
China
Tel: +86 21 62351596
Fax: +86 21 62351595

E-mail (Sales) cn.sales@ftdichip.com
E-mail (Support) cn.support@ftdichip.com
E-mail (General Enquiries) cn.admin@ftdichip.com

Web Site

<http://ftdichip.com>

Distributor and Sales Representatives

Please visit the Sales Network page of the [FTDI Web site](#) for the contact details of our distributor(s) and sales representative(s) in your country.

System and equipment manufacturers and designers are responsible to ensure that their systems, and any Future Technology Devices International Ltd (FTDI) devices incorporated in their systems, meet all applicable safety, regulatory and system-level performance requirements. All application-related information in this document (including application descriptions, suggested FTDI devices and other materials) is provided for reference only. While FTDI has taken care to assure it is accurate, this information is subject to customer confirmation, and FTDI disclaims all liability for system designs and for any applications assistance provided by FTDI. Use of FTDI devices in life support and/or safety applications is entirely at the user's risk, and the user agrees to defend, indemnify and hold harmless FTDI from any and all damages, claims, suits or expense resulting from such use. This document is subject to change without notice. No freedom to use patents or other intellectual property rights is implied by the publication of this document. Neither the whole nor any part of the information contained in, or the product described in this document, may be adapted or reproduced in any material or electronic form without the prior written consent of the copyright holder. Future Technology Devices International Ltd, Unit 1, 2 Seaward Place, Centurion Business Park,

Appendix A – References

Document References

[FT4222H Datasheet](#)

Acronyms and Abbreviations

Terms	Description
DUT	Device Under Test
IC	Integrated Circuit
LED	Light Emitting Diode
OTP	One Time Programmable
USB	Universal Serial Bus

Appendix B –List of Figures and Tables

List of Figures

Figure 3-1 UMFT4222PROG-IC connection example.....	4
Figure 3-2 Example Function block of FT4222H integrated LDO regulator.....	5
Figure 4-1 UMFT4222PROG-IC module layout.....	6
Figure 5-1 Circuit Schematic of UMFT4222PROG-IC	8
Figure 5-2 Circuit Schematic of UMFT4222PROG-IC	9

List of Tables

Table 2-1 UMFT4222 Product Descriptions and Part Numbers	2
Table 3-1 UMFT4222PROG-IC LED Indication	5
Table 4-1 UMFT4222PROG module Connections (numbers refer to pad numbers on the PCB)	6

Appendix C - Revision History

Document Title: UMFT4222 Programmer-IC Module Datasheet
Document Reference No.: FT_001132
Clearance No.: FTDI#427
Product Page: <http://www.ftdichip.com/FTProducts.html>
Document Feedback: [DS_UMFT4222PROG-IC](#)

Revision	Changes	Date
1.0	Initial Release	2014-12-03
1.1	Updated Ordering Information	2016-06-06
1.2	Updated Ordering information & programming procedures	2017-06-27

X-ON Electronics

Largest Supplier of Electrical and Electronic Components

Click to view similar products for [Programmiers - Universal & Memory Based](#) category:

Click to view products by [FTDI](#) manufacturer:

Other Similar products are found below :

[DG-ACC-LX-DVD](#) [DSC-PROG-TIMEFLASH-2520](#) [4D-UPA](#) [AS5XXX-EK-USB-PB](#) [CT002-S](#) [UMFT4222PROG-IC](#) [PDS4102-PM300N](#)
[SUPERPRO 6100N](#) [SUPERPRO 610P](#) [AS5000 PROGRAMMER](#) [844USB](#) [866C](#) [CHIPMAX2](#) [PROMAX 2 -4G](#) [TOPMAX III](#)
[UMFT4222PROG](#)