

Positive Temperature Coefficient (PTC) Data Sheet

Description

The 1206 series provides miniature surface mount resettable overcurrent protection withholding current from 0.05A to 2.0A. This series is suitable for wide range of applications in modern electronics where space is limited.

Features

- ROHS compliant and lead-free
- Fast response to fault current
- Low profile
- Low resistance
- Compatible with high temperature solders
- Compact design saves board space

Applications

- USB peripherals
- Disk drives
- CD-ROMs
- Plug and play protection for motherboards and peripherals
- Mobile phones-battery and port protection
- PDAs/digital cameras
- Game console port protection
- Type-C
- HDMI and Set-top-box

Electrical Characteristics

Part Number	Marking	I _{hold} (A)	I _{trip} (A)	V _{max} (V)	I _{max} (A)	Pd typ. (W)	Maximum time to trip		Resistance	
							Time(s)	Current(A)	R _{min} (Ω)	R _{1max} (Ω)
FTR1206-005	5	0.05	0.15	30	100	0.6	0.25	1.5	3.6	50
FTR1206-010	01	0.10	0.27	30	100	0.6	0.20	1.5	1.5	15
FTR1206-012	1E	0.12	0.29	30	100	0.6	0.20	1.0	1.5	6
FTR1206-016	1L	0.16	0.37	30	100	0.6	0.30	1.0	1.2	4.5
FTR1206-020/24	02	0.20	0.42	24	100	0.6	0.10	8.0	0.65	2.6
FTR1206-025	2W	0.25	0.50	16	100	0.6	0.08	8.0	0.55	2.3
FTR1206-025/24	2S	0.25	0.55	24	100	0.6	0.08	8.0	0.55	2.3
FTR1206-035/16	03	0.35	0.75	16	100	0.6	0.10	8.0	0.3	1.2
FTR1206-050	05	0.50	1.00	6	100	0.6	0.10	8.0	0.15	0.7
FTR1206-050/15	05	0.50	1.00	15	100	0.6	0.10	8.0	0.15	0.75
FTR1206-075	75	0.75	1.50	8	100	0.6	0.20	8.0	0.09	0.35
FTR1206-075/13.2	73	0.75	1.50	13.2	100	0.6	0.20	8.0	0.09	0.35
FTR1206-075/16	76	0.75	1.50	16	100	0.6	0.20	8.0	0.09	0.35
FTR1206-110	11	1.10	2.20	8	100	0.8	0.10	8.0	0.04	0.21
FTR1206-150	15	1.5	3	8	100	0.8	0.3	8	0.03	0.12
FTR1206-175	17	1.75	3.5	6	100	0.8	0.5	8	0.02	0.09
FTR1206-200	20	2	3.5	6	100	0.8	1.5	8	0.02	0.08

·I_{hold}= Hold current: maximum current device will pass without tripping in 23°C still air.

·I_{trip}= Trip current: minimum current at which the device will trip in 23°C still air.

·V_{max}= Maximum voltage device can withstand without damage at rated current (I_{max})

·I_{max}= Maximum fault current device can withstand without damage at rated voltage (V_{max})

·Pd typ.= Typical power dissipated from device when in the tripped state at 23°C still air.

·R_{min}= Minimum resistance of device in initial (un-soldered) state.

·R_{1max}= Maximum resistance of device at 23°C measured one hour after tripping or reflow soldering of 260°C for 20 sec.

■Caution: Operation beyond the specified rating may result in damage and possible arcing and flame.

Part Number	Ambient Operation Temperature								
	-40°C	-20°C	0°C	23°C	40°C	50°C	60°C	70°C	85°C
FTR1206-005	0.074	0.066	0.058	0.050	0.043	0.038	0.035	0.030	0.028
FTR1206-010	0.180	0.160	0.140	0.100	0.100	0.090	0.080	0.070	0.050
FTR1206-012	0.180	0.160	0.140	0.125	0.100	0.090	0.080	0.070	0.050
FTR1206-016	0.220	0.200	0.180	0.160	0.140	0.120	0.100	0.090	0.080
FTR1206-020/24	0.280	0.250	0.230	0.200	0.170	0.150	0.140	0.120	0.090
FTR1206-025	0.370	0.330	0.290	0.250	0.220	0.200	0.170	0.150	0.120
FTR1206-025/24	0.370	0.330	0.290	0.250	0.220	0.200	0.170	0.150	0.120
FTR1206-035/16	0.500	0.450	0.400	0.350	0.300	0.270	0.240	0.210	0.150
FTR1206-050	0.710	0.640	0.570	0.500	0.420	0.390	0.350	0.310	0.250
FTR1206-050/15	0.710	0.640	0.570	0.500	0.420	0.390	0.350	0.310	0.250
FTR1206-075	1.140	1.010	0.880	0.750	0.650	0.590	0.540	0.490	0.410
FTR1206-075/13.2	1.140	1.010	0.880	0.750	0.650	0.590	0.540	0.490	0.410
FTR1206-075/16	1.140	1.010	0.880	0.750	0.650	0.590	0.540	0.490	0.410
FTR1206-110	1.640	1.460	1.300	1.100	0.920	0.830	0.800	0.650	0.520
FTR1206-150	2.200	1.990	1.770	1.500	1.340	1.230	1.100	1.010	0.840
FTR1206-175	2.500	2.250	2.000	1.750	1.550	1.450	1.350	1.250	1.100
FTR1206-200	2.600	2.440	2.350	2.000	1.780	1.670	1.500	1.450	1.200

Dimensions and PAD Size

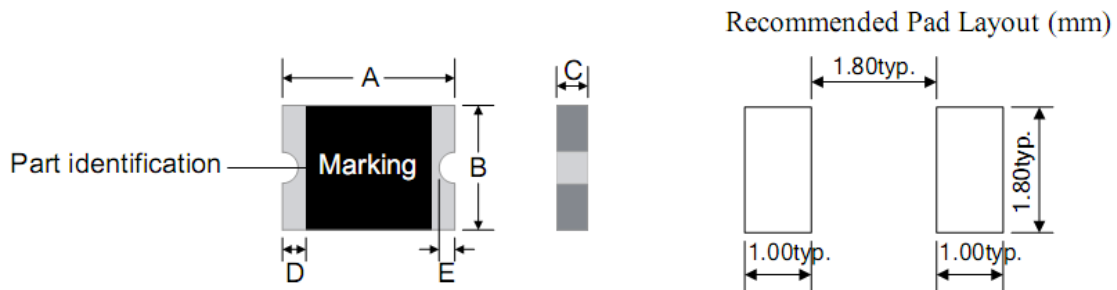

Part Number	A		B		C		D		E	
	Min.	Max.	Min.	Max.	Min.	Max.	Min.	Max.	Min.	Max.
FTR1206-005	3.00	3.40	1.50	1.80	0.65	1.45	0.25	0.75	0.05	0.45
FTR1206-010	3.00	3.40	1.50	1.80	0.65	1.45	0.25	0.75	0.05	0.45
FTR1206-012	3.00	3.40	1.50	1.80	0.65	1.45	0.25	0.75	0.05	0.45
FTR1206-016	3.00	3.40	1.50	1.80	0.65	1.45	0.25	0.75	0.05	0.45
FTR1206-020/24	3.00	3.40	1.50	1.80	0.50	1.45	0.25	0.75	0.05	0.45
FTR1206-025	3.00	3.40	1.50	1.80	0.50	1.25	0.25	0.75	0.05	0.45
FTR1206-025/24	3.00	3.40	1.50	1.80	0.50	1.25	0.25	0.75	0.05	0.45
FTR1206-035/16	3.00	3.40	1.50	1.80	0.45	1.00	0.25	0.75	0.05	0.45
FTR1206-050	3.00	3.40	1.50	1.80	0.45	0.85	0.25	0.75	0.05	0.45
FTR1206-050/15	3.00	3.40	1.50	1.80	0.45	1.45	0.25	0.75	0.05	0.45
FTR1206-075	3.00	3.40	1.50	1.80	0.40	1.45	0.25	0.75	0.05	0.45
FTR1206-075/13.2	3.00	3.40	1.50	1.80	0.40	1.60	0.25	0.75	0.05	0.45

Part Number	A		B		C		D		E	
	Min.	Max.	Min.	Max.	Min.	Max.	Min.	Max.	Min.	Max.
FTR1206-075/16	3.00	3.40	1.50	1.80	0.40	1.60	0.25	0.75	0.05	0.45
FTR1206-110	3.00	3.40	1.50	1.80	0.30	1.25	0.25	0.75	0.05	0.45
FTR1206-150	3.00	3.40	1.50	1.80	0.50	1.60	0.25	0.75	0.05	0.45
FTR1206-175	3.00	3.40	1.50	1.80	0.80	1.80	0.25	0.75	0.05	0.45
FTR1206-200	3.00	3.40	1.50	1.80	0.80	1.60	0.25	0.75	0.05	0.45

Recommended Soldering Conditions

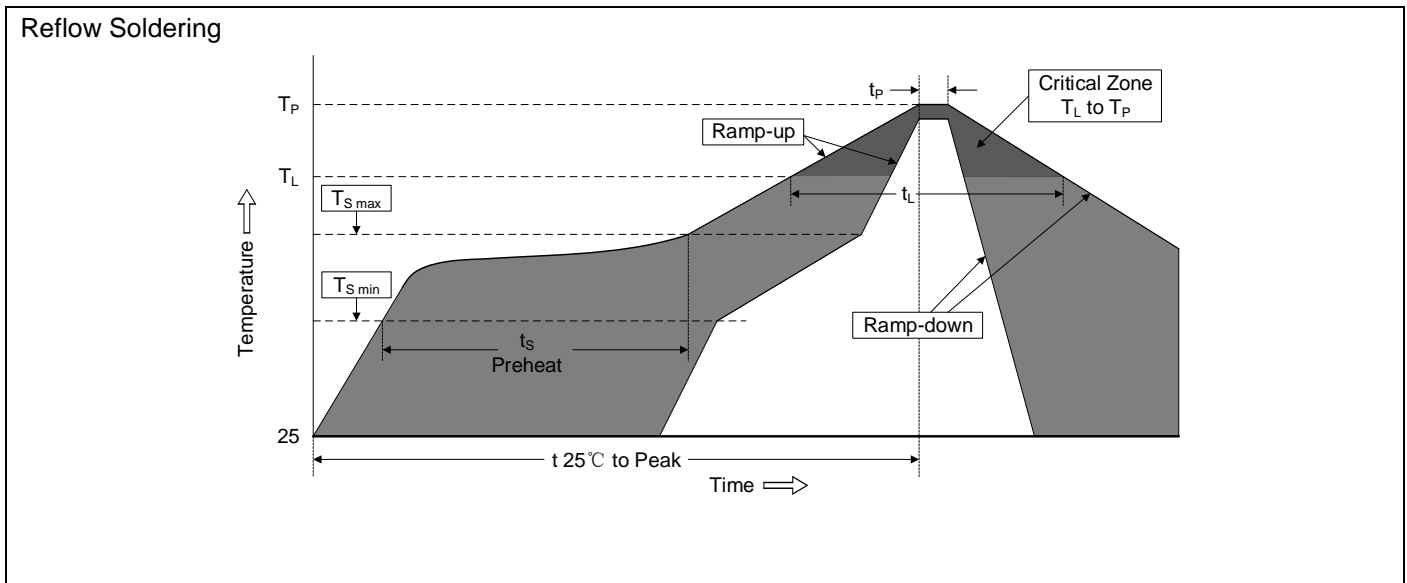

Recommended Conditions

Profile Feature	Pb-Free Assembly
Average ramp-up rate (T_L to T_P)	3°C/second max.
Preheat	
-Temperature Min ($T_{S\ min}$)	150°C
-Temperature Max ($T_{S\ max}$)	200°C
-Time (min to max) (t_s)	60-180 seconds
$T_{S\ max}$ to T_L	
-Ramp-up Rate	3°C/second max.
Time maintained above:	
-Temperature (T_L)	217°C
-Time (t_L)	60-150 seconds
Peak Temperature (T_P)	260°C
Time within 5°C of actual Peak Temperature (t_p)	20-40 seconds
Ramp-down Rate	6°C/second max.
Time 25°C to Peak Temperature	8 minutes max.
Storage Condition	0°C ~ 35°C, ≤70%RH

-Recommended reflow methods: IR, vapor phase oven, hot air oven, N₂ environment for lead-free

-Recommended maximum paste thickness is 0.25mm (0.010 inch)

-Device can be cleaned using standard industry methods and solvents.

Note 1: All temperature refer to topside of the package, measured on the package body surface.

Note 2: If reflow temperatures exceed the recommended profile, devices may not meet the performance requirements.

Partnumber code

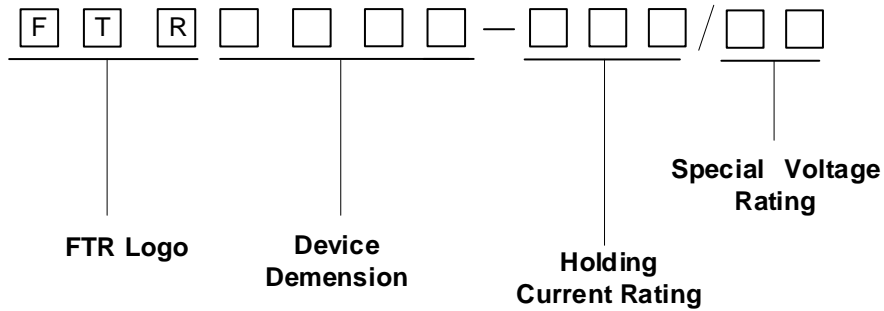

Environmental Specifications

Operating / Storage temperature	-40°C to +85°C
Maximum Device Surface Temperature in Tripped State	125°C
Passive Aging	+85°C, 1000 hours ±50% typical resistance change
Humidity Aging	+85°C, 85%RH, 1000 hours ±50% typical resistance change
Thermal Shock	MIL-STD-202, Method 107G +85°C/-40°C 20 times -50% typical resistance change
Solvent Resistance	MIL-STD-202, Method 215 No change
Vibration	MIL-STD-883C, Method 2007.1, Condition A No change
Moisture Level Sensitivity	Level 1, J-STD-020C

Physical Specifications

Terminal Material	Solder-Plated Copper (Solder Material: Matte Tin (Sn))
Terminal Solderability	Meets EIA Specification RS186-9E, ANSI/J-STD-002 Category 3.

Packaging

Part Number	Quantity	Part Number	Quantity	Part Number	Quantity
FTR1206-005	3000	FTR1206-025/24	4000	FTR1206-075/16	2000
FTR1206-010	4000	FTR1206-035/16	4000	FTR1206-110	4000
FTR1206-012	4000	FTR1206-050	4000	FTR1206-150	2000
FTR1206-016	4000	FTR1206-050/15	3000	FTR1206-175	2000
FTR1206-020/24	4000	FTR1206-075	4000	FTR1206-200	2000
FTR1206-025	4000	FTR1206-075/13.2	2000		

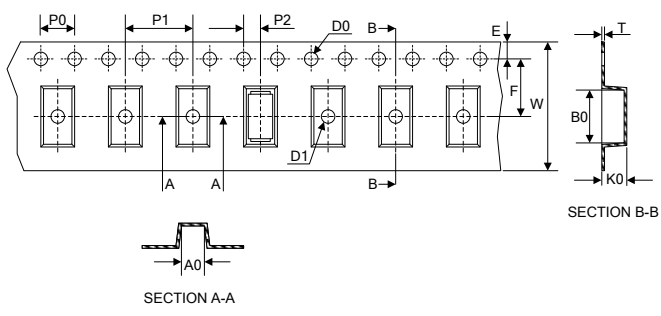
Tape	Symbol	Dimension (mm)			
		010,012,016 020/24,025 025/24,035/24 050,075,110	005 050/15	075/13.2, 075/16, 150,175,200	
	W	8.00±0.30	8.00±0.30	8.00±0.30	
	P0	4.00±0.10	4.00±0.10	4.00±0.10	
	P1	4.00±0.10	4.00±0.10	4.00±0.10	
	P2	2.00±0.10	2.00±0.10	2.00±0.10	
	D0	Φ1.55±0.10	Φ1.55±0.10	Φ1.55±0.10	
	D1	Φ1.0±0.10	Φ1.0±0.10	Φ1.0±0.10	
	E	1.75±0.10	1.75±0.10	1.75±0.10	
	F	3.50±0.05	3.50±0.05	3.50±0.05	
	A0	1.95±0.1	1.92±0.1	1.95±0.1	
	B0	3.65±0.1	3.65±0.1	3.65±0.1	
	K0	0.87±0.1	1.30±0.1	1.70±0.1	
	T	0.20±0.1	0.25±0.1	0.25±0.1	
	Reel	C	Φ178.0±1.0		
		D	Φ60.2±0.5		
H		11.0±0.5			
W		9.0±1.5			

X-ON Electronics

Largest Supplier of Electrical and Electronic Components

Click to view similar products for [Resettable Fuses - PPTC](#) category:

Click to view products by [FTR](#) manufacturer:

Other Similar products are found below :

[RF0077-000](#) [RF3256-000](#) [RF3281-000](#) [RF3301-000](#) [RF3344-000](#) [RF3382-000](#) [SMD125-2](#) [RF2171-000](#) [RF2531-000](#) [RF2873-000](#) [RF3060-000](#) [TR600-150Q-B-0.5-0.130](#) [RXE090](#) [5E4795/04-1502](#) [TRF250-080T-B-1.0-0.125](#) [SMD100-2](#) [NIS5452MT1TXG](#) [NIS5431MT1TXG](#) [SMD250-2](#) [0ZCM0001FF2G](#) [0ZCM0003FF2G](#) [0ZCM0004FF2G](#) [BK60-017-DZ-E0.6](#) [F95456-000](#) [LVR100S](#) [RS30-090](#) [RS30-600](#) [RS30-700](#) [RS30-800](#) [RS30-900](#) [RS60RB-005](#) [RS60RB-010](#) [RS60RB-020](#) [RS60RB-025](#) [RS60RB-050](#) [RS60RB-075](#) [RS60RB-160](#) [ASMD0603-010-30V](#) [ASMD0603-025-16V](#) [ASMD2920-260-24V](#) [BSMD0603-025-12V](#) [BSMD1206-150-12V](#) [BSMD0805-020-33V](#) [BSMD1206-075-13.2V](#) [BSMD2920-400-6V](#) [BSMD2920-300-6V](#) [BSMD2920-700-6V](#) [SMD1812-750-12V](#) [SMD1206-300C-12V](#) [SB250-145](#)