

# POWER RELAY

## 1 POLE - 25A - Latching relay

### FTR-K3L-WG Series

#### ■ FEATURES

- 1 pole, 25A
  - 2 coils latching type
  - 1 Form A
  - Contact gap 1.5mm  
2.5kV surge breakdown voltage  
Compliance with European photovoltaic standard (VDE0126)
  - High insulation in small package  
(between coil and contact)
    - Insulation distance: Clearance > 6.4mm  
Creepage > 9.5mm
    - Dielectric strength: 5,000VAC
    - Surge strength: 8,500V
  - Flammability UL94V-0 (plastics)
  - Flux proof
  - RoHS compliant
- Please see page 6 for more information  
Contains no lead and features cadmium-free contacts

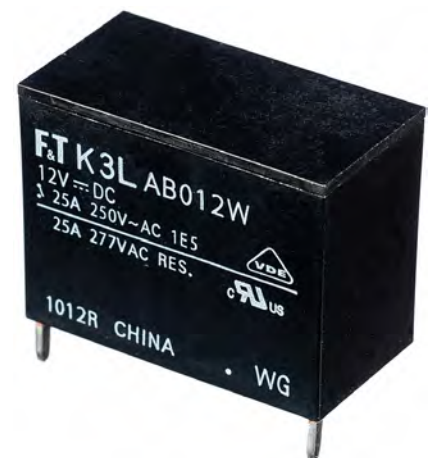

#### ■ PARTNUMBER INFORMATION

[Example]      FTR-K3L    A    B    012    W    -    WG  
                   (a)    (b)    (c)    (d)    (e)    (f)

(a)	Relay type	FTR-K3L : FTR-K3L Series
(b)	Contact configuration	A : 1 form A
(c)	Coil type	B : Standard sensitive (900mW)
(d)	Coil rated voltage	012 : 5.....24 VDC Coil rating table at page 3
(e)	Contact material	W : Silver alloy
(f)	Version	WG : Contact gap 1.5mm

Actual marking does not carry the type name : "FTR"

E.g.: Ordering code: FTR-K3LAB012W-WG

Actual marking: K3LAB012W-WG

# FTR-K3L-WG SERIES

## ■ SPECIFICATION

Item	FTR-K3L-WG		
Contact Data	Configuration		1 form A (contact gap 1.5mm)
	Material		Silver alloy
	Resistance (initial)		Max. 100mΩ at 1A, 6VDC
	Contact rating		25A / 250VAC (resistive)
	Max. carrying current		30A
	Max. switching power		6,250VA
	Max. switching voltage		250VAC
	Max. switching current		25A
	Min. switching load (reference)		100mA, 5VDC
Life	Mechanical		Min. 1 x 10 <sup>6</sup> operations
	Electrical	Resistive	25A, 250VAC, 100 x 10 <sup>3</sup> operations
		Inductive	25A, 250VAC (cosφ=0.8), 30 x 10 <sup>3</sup> operations
		Inductive (overload)	37.5A, 250VAC (cosφ=0.8), 50 operations
Coil Data	Rated power (at 20 °C)		900mW
	Operating temperature range (no frost)		-40 °C to +85 °C
Timing Data	Set (at nominal voltage)		Max. 20ms (without bounce, without diode)
	Reset (at nominal voltage)		Max. 20ms (without bounce, without diode)
	Coil excitation time (at nominal voltage)		Min. 30ms, max. 1,000ms
Insulation	Contact gap		Min. 1.5 mm
	Resistance		Min. 1,000MΩ at 500VDC
	Dielectric strength	Open contacts	2,500VAC, 1min.
		Coil and contacts	5,000VAC, 1min.
	Surge strength	Coil to contacts	8,500V/ 1.2 x 50μs standard wave
	Creepage		6.4mm
	Clearance		9.5mm
Other	Vibration resistance	Misoperation	10 to 55 to 10Hz single amplitude 0.825 mm
		Endurance	10 to 55 to 10Hz single amplitude 1.0 mm
	Shock resistance	Misoperation	Min. 200m/s <sup>2</sup> (11 ± 1ms)
		Endurance	Min. 1,000m/s <sup>2</sup> (6 ± 1ms)
	Weight		Approximately 25 g

\* Minimum switching loads mentioned above are reference values. Please perform the confirmation test with actual load before production since reference values may vary according to switching frequencies, environmental conditions and expected reliability levels.

Note: Care shall be taken on the heat generated on PC board when maximum carrying current exceeds 10A. Please perform the confirmation test with actual conditions.

# FTR-K3L-WG SERIES

## ■ COIL RATING

Coil Code	Rated Coil Voltage (VDC)	Coil Resistance +/- 10% (Ohm)	Must Set Voltage (VDC)*	Must Reset Voltage (VDC) *	Max. Set/Reset Voltage (VDC)	Rated Power (mW)
005	5	P 28	+4.0	-	9.0	900
		S 28	-	+4.0		
006	6	P 40	+4.8	-	10.8	
		S 40	-	+4.8		
012	12	P 160	+9.6	-	21.6	
		S 160	-	+9.6		
024	24	P 640	+19.2	-	43.2	
		S 640	-	+19.2		

Note: All values in the table are valid for 20°C and zero contact current.

P: Set coil S: Reset coil

\* Specified operate values are valid for pulse wave voltage.

- ⚠ Please use at rated coil voltage. DO NOT apply voltage that exceeds maximum applied voltage continuously. Insulation may decrease.
- ⚠ DO NOT apply voltage that exceeds maximum applied voltage on to reset coil. It may cause operation failure.

## ■ SAFETY STANDARDS

Type	Compliance	Contact rating
UL	UL 508 CSA 22.2 No.14 (by cULus)  (E63614)	Flammability: UL 94-V0 (plastics)
		25A, 277VAC (General Use, at 85°C)
VDE	IEC/EN61810-1	25A, 250VAC, (cosφ=1) at 85°C 25A, 250VAC, (cosφ=0.8) at 85°C

# FTR-K3L-WG SERIES

## CHARACTERISTIC DATA

(Characteristic data is not guaranteed value but measured values of samples from production line.)

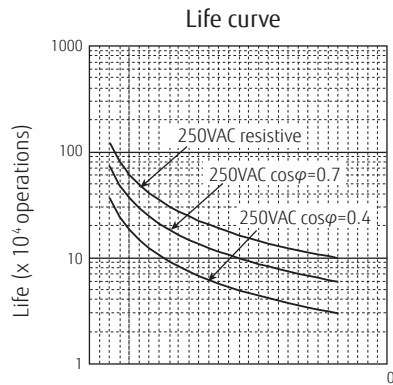
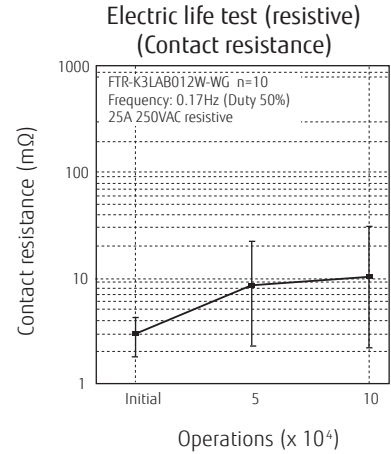
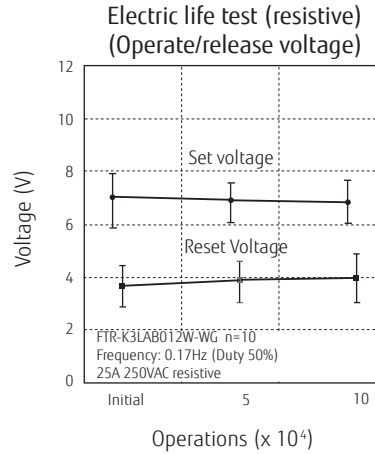
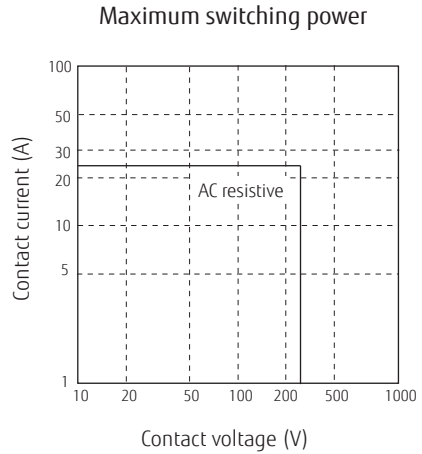

## ■ DIMENSIONS

### ● Dimensions

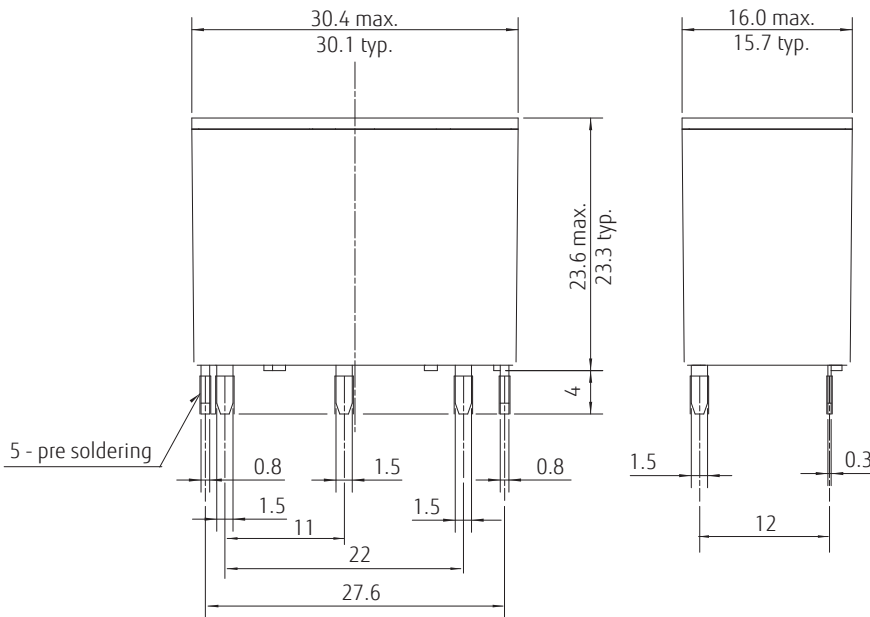

\* Dimensions of the terminals do not include thickness of pre-solder.

### ● Schematics (BOTTOM VIEW)

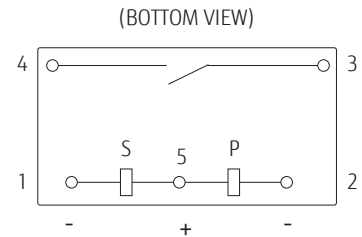

P: Set coil  
S: Reset coil

\* Contacts drawn in reset condition.

\* To operate (set), apply + to pin 5 and - to pin 2.  
To release (reset), apply + to pin 5 and - to pin 1.

### ● PC board mounting hole layout (BOTTOM VIEW)

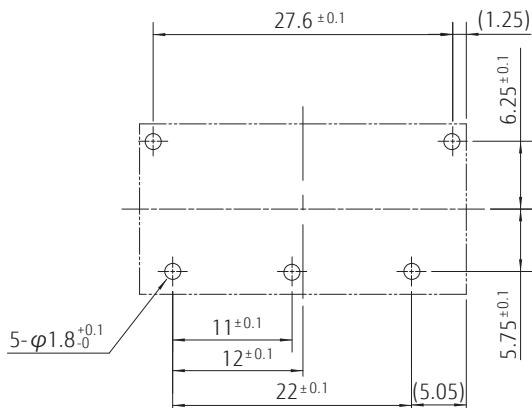

Unit: mm  
( ): Reference

### Cautions

- All values mentioned in this datasheet are provided under ideal conditions. Please perform the confirmation test before actual use.
- Reflow soldering is prohibited.
- Do not use relays in the atmosphere with sulfide gas, chloride gas or nitric oxide. Contact resistance may increase.
- Do not use silicon or silicon-containing product or materials near relays. It may cause contact failure.
- Please connect relay coils according to specified polarity.

### Notes for latching relay

- Latching relays are shipped in the state set, but state may change due to shock during transportation or mounting. Before using the relays, it is advisable to bring the relays in necessary state (set or reset) and program a circuit sequence. Otherwise, it will or will not operate simultaneously with power activation.
- Please connect relay coils according to specified polarity.
- Do not apply voltage to both set coil and reset coil at a time.

## RoHS Compliance and Lead Free Information

### 1. General Information

- All relays produced by Fujitsu Components are compliant with RoHS directive 2011/65/EU including amendments.
- Cadmium as used in electrical contacts is exempted from the RoHS directives.  
As per Annex III of directive 2011/65/EU.
- All relays are lead-free. Please refer to Lead-Free Status Info for older date codes at:  
<http://www.fujitsu.com/downloads/MICRO/fcai/relays/lead-free-letter.pdf>
- Lead free solder plating on relay terminals is Sn-3.0Ag-0.5Cu, unless otherwise specified.  
This material has been verified to be compatible with PbSn assembly process.

### 2. Recommended Lead Free Solder Condition

- Recommended solder Sn-3.0Ag-0.5Cu.

#### Flow Solder Condition:

Pre-heating: maximum 120°C  
within 9 sec.  
Soldering: dip within 5 sec. at  
255°C ± 5°C solder bath  
Relay must be cooled by air immediately  
after soldering

#### Solder by Soldering Iron:

Soldering Iron 30-60W  
Temperature: maximum 350-360°C  
Duration: maximum 3 sec.

**We highly recommend that you confirm your actual solder conditions**

### 3. Moisture Sensitivity

- Moisture Sensitivity Level standard is not applicable to electromechanical relays, unless otherwise indicated.

### 4. Tin Whiskers

- Dipped SnAgCu solder is known as presenting a low risk to tin whisker development. No considerable length whisker was found by our in house test.

## Fujitsu Components International Headquarter Offices

### Japan

FUJITSU COMPONENT LIMITED  
Shinagawa Seaside Park Tower 19F,  
12-4, Higashi-shinagawa 4-chome, Shinagawa-ku,  
Tokyo, 140-0002, Japan  
Tel: (81-3) 3450-1682  
Fax: (81-3) 3474-2385  
Email: fcl-contact@cs.jp.fujitsu.com  
Web: www.fujitsu.com/jp/fcl/

### North and South America

FUJITSU COMPONENTS AMERICA, INC  
2290 North First Street, Suite 212  
San Jose, CA 95131, USA  
Tel: (1-408) 745-4900  
Fax: (1-408) 745-4970  
Email: components@us.fujitsu.com  
Web: us.fujitsu.com/components

### Europe

FUJITSU COMPONENTS EUROPE B.V.  
Diamantlaan 25  
2132 WV Hoofddorp  
Netherlands  
Tel: (31-23) 5560910  
Fax: (31-23) 5560950  
Email: info@fceu.fujitsu.com  
Web: www.fujitsu.com/uk/components

### Asia Pacific

FUJITSU COMPONENTS ASIA, LTD.  
102E Pasir Panjang Road  
#01-01 Citilink Warehouse Complex  
Singapore 118529  
Tel: (65) 6375-8560  
Fax: (65) 6273-3021  
Email: fcal@sg.fujitsu.com  
Web: www.fujitsu.com/sg/products/devices/components

### China

FUJITSU ELECTRONIC COMPONENTS (SHANGHAI) CO., LTD.  
Unit 4306, InterContinental Center  
100 Yu Tong Road, Shanghai 200070,  
China  
Tel: (86-21) 3253 0998  
Fax: (86-21) 3253 0997  
Email: fcal@sg.fujitsu.com  
Web: www.fujitsu.com/sg/products/devices/components

### Hong Kong

FUJITSU COMPONENTS HONG KONG CO., LTD  
Unit 506, Inter-Continental Plaza  
No.94 Granville Road, Tsim Sha Tsui, Kowloon,  
Hong Kong  
Tel: (852) 2881-8495  
Tex: (852) 2894-9512  
Email: fcal@sg.fujitsu.com  
Web: www.fujitsu.com/sg/products/devices/components/

### Korea

FUJITSU COMPONENTS KOREA LIMITED  
Alpha Tower #403, 645 Sampyeong-dong,  
Bundang-gu, Seongnam-si, Gyeonggi-do,  
13524 Korea  
Tel: (82) 31-708-7108  
Fax: (82) 31-709-7108  
Email: fcal@sg.fujitsu.com  
www.fujitsu.com/sg/products/devices/components/

©2020 Fujitsu Components Europe B.V. All rights reserved. All trademarks or registered trademarks are the property of their respective owners.

The contents, data and information in this datasheet are provided by Fujitsu Component Ltd. as a service only to its user and only for general information purposes.

The use of the contents, data and information provided in this datasheet is at the users' own risk.

Fujitsu has assembled this datasheet with care and will endeavor to keep the contents, data and information correct, accurate, comprehensive, complete and up to date.

Fujitsu Components Europe B.V. and affiliated companies do however not accept any responsibility or liability on their behalf, nor on behalf of its employees, for any loss or damage, direct, indirect or consequential, with respect to this datasheet, its contents, data, and information and related graphics and the correctness, reliability, accuracy, comprehensiveness, usefulness, availability and completeness thereof.

Nor do Fujitsu Components Europe B.V. and affiliated companies accept on their behalf, nor on behalf of its employees, any responsibility or liability for any representation or warrant of any kind, express or implied, including warranties of any kind for merchantability or fitness for particular use, with respect to these datasheets, its contents, data, information and related graphics and the correctness, reliability, accuracy, comprehensiveness, usefulness, availability and completeness thereof. Rev. July 21, 2020

## X-ON Electronics

Largest Supplier of Electrical and Electronic Components

*Click to view similar products for [General Purpose Relays](#) category:*

*Click to view products by [Fujitsu](#) manufacturer:*

Other Similar products are found below :

[PCN-105D3MH,000](#) [59641F200](#) [LY1SAC110120](#) [5X827E](#) [5X837F](#) [5X840F](#) [5X842F](#) [5X848E](#) [LY2N-AC120](#) [LY2S-AC220/240](#) [LY2-US-AC120](#) [LY3-US-AC120](#) [LY4F-UA-DC12](#) [LY4F-UA-DC24](#) [LY4F-US-AC120](#) [LY4F-US-AC240](#) [LY4F-US-DC24](#) [LY4F-VD-AC110](#) [LYQ20DC12](#) [M115C60](#) [M115N010](#) [M115N0150](#) [6031007G](#) [603-12D](#) [61211T0B4](#) [61212T400](#) [61222Q400](#) [61243B600](#) [61243C500](#) [61243Q400](#) [61311BOA2](#) [61311BOA6](#) [61311BOA8](#) [61311C0A2](#) [61311COA1](#) [61311COA6](#) [61311F0A2](#) [61311QOA1](#) [61311QOA4](#) [61311T0D6](#) [61311TOA6](#) [61311TOA7](#) [61311TOB3](#) [61311TOB4](#) [61311U0A6](#) [61312Q600](#) [61312T400](#) [61312T600](#) [61313U200](#) [61313U400](#)