

# Memory FRAM

## 16 K (2 K × 8) Bit I<sup>2</sup>C

# MB85RC16

### ■ DESCRIPTION

The MB85RC16 is an FRAM (Ferroelectric Random Access Memory) chip in a configuration of 2,048 words × 8 bits, using the ferroelectric process and silicon gate CMOS process technologies for forming the nonvolatile memory cells.

Unlike SRAM, the MB85RC16 is able to retain data without using a data backup battery.

The memory cells used in the MB85RC16 have at least 10<sup>10</sup> Read/Write operation endurance per bit, which is a significant improvement over the number of read and write operations supported by other nonvolatile memory products.

The MB85RC16 can provide writing in one byte units because the long writing time is not required unlike Flash memory and E<sup>2</sup>PROM. Therefore, the writing completion waiting sequence like a write busy state is not required.

### ■ FEATURES

- Bit configuration : 2,048 words × 8 bits
- Operating power supply voltage : 2.7 V to 3.6 V
- Operating frequency : 1 MHz (Max)
- Two-wire serial interface : Fully controllable by two ports: serial clock (SCL) and serial data (SDA).
- Operating temperature range : - 40 °C to + 85 °C
- Data retention : 10 years ( + 75 °C)
- Read/Write endurance : 10<sup>10</sup> times
- Package : Plastic / SOP, 8-pin (FPT-8P-M02)
- Low power consumption : Operating current 0.1mA (Max: @1 MHz), Standby current 0.1 μA (Typ)

# MB85RC16

## ■ PIN ASSIGNMENT

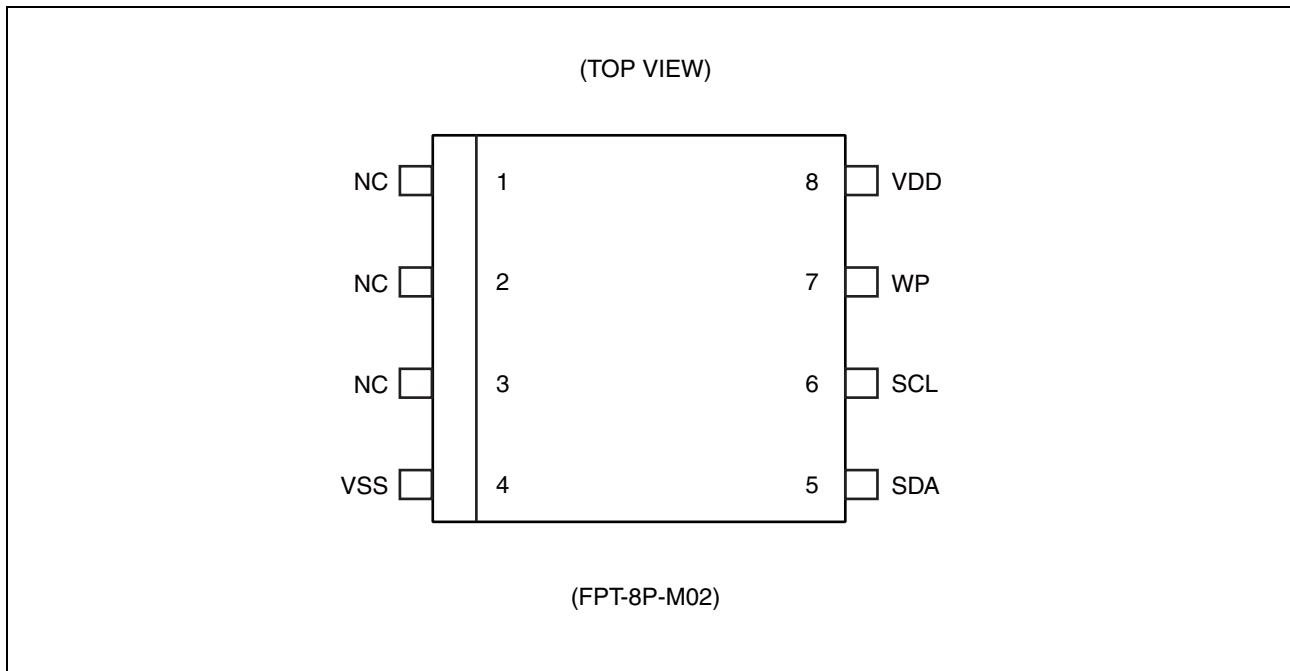

## ■ PIN FUNCTIONAL DESCRIPTIONS

Pin Number	Pin Name	Functional Description
1 to 3	NC	Unconnected pins Leave it unconnected.
4	VSS	Ground pin
5	SDA	Serial Data I/O pin This is an I/O pin of serial data for performing bidirectional communication of memory address and writing or reading data. It is possible to connect some devices. It is an open drain output, so a pull-up resistance is required to be connected to the external circuit.
6	SCL	Serial Clock pin This is a clock input pin for input/output timing serial data. Data is sampled on the rising edge of the clock and output on the falling edge.
7	WP	Write Protect pin When Write Protect pin is "H" level, writing operation is disabled. When Write Protect pin is "L" level, the entire memory region can be overwritten. Reading operation is always enabled regardless of the Write Protect pin state. The write protect pin is internally pulled down to VSS pin, and that is recognized as "L" level (the state that writing is enabled) when the pin is the open state.
8	VDD	Supply Voltage pin

## ■ BLOCK DIAGRAM

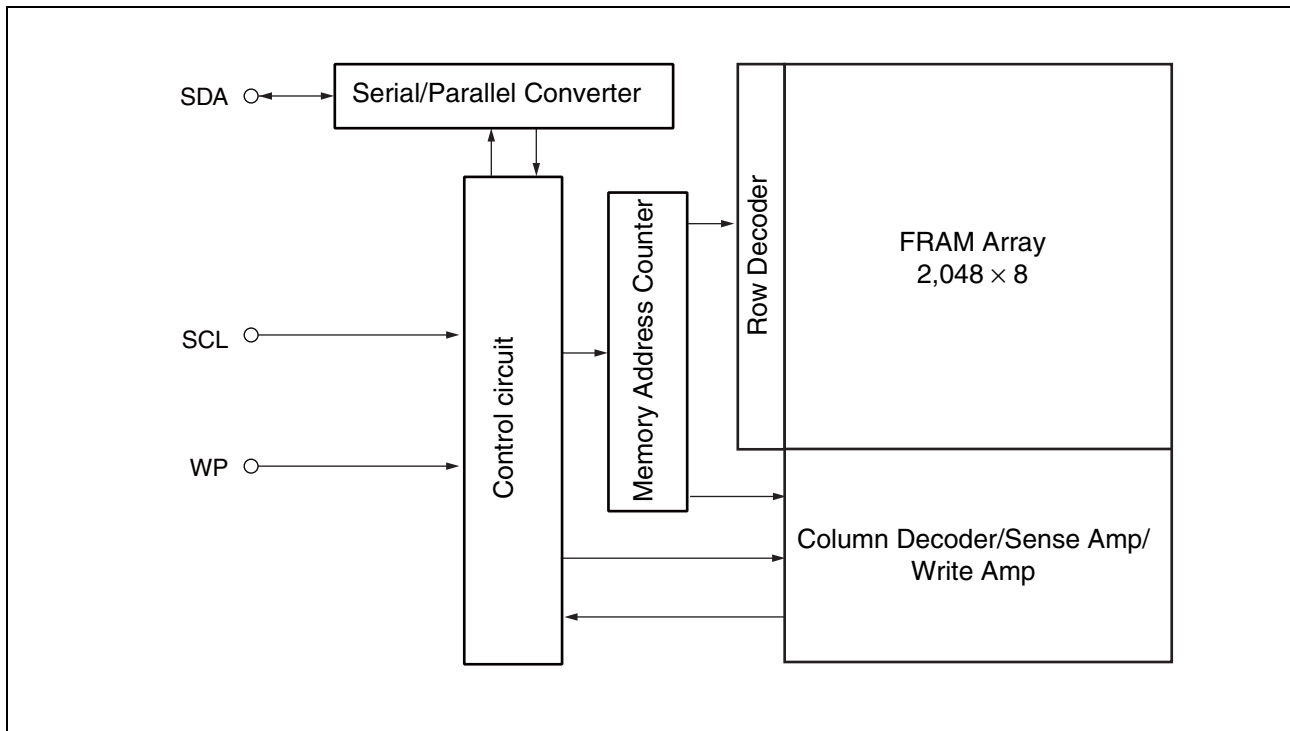

## ■ I<sup>2</sup>C (Inter-Integrated Circuit)

The MB85RC16 has the two-wire serial interface and the I<sup>2</sup>C bus, and operates as a slave device.

The I<sup>2</sup>C bus defines communication roles of “master” and “slave” devices, with the master side holding the authority to initiate control. Furthermore, a I<sup>2</sup>C bus connection is possible where a single master device is connected to multiple slave devices in a party-line configuration.

### • I<sup>2</sup>C Interface System Configuration Example

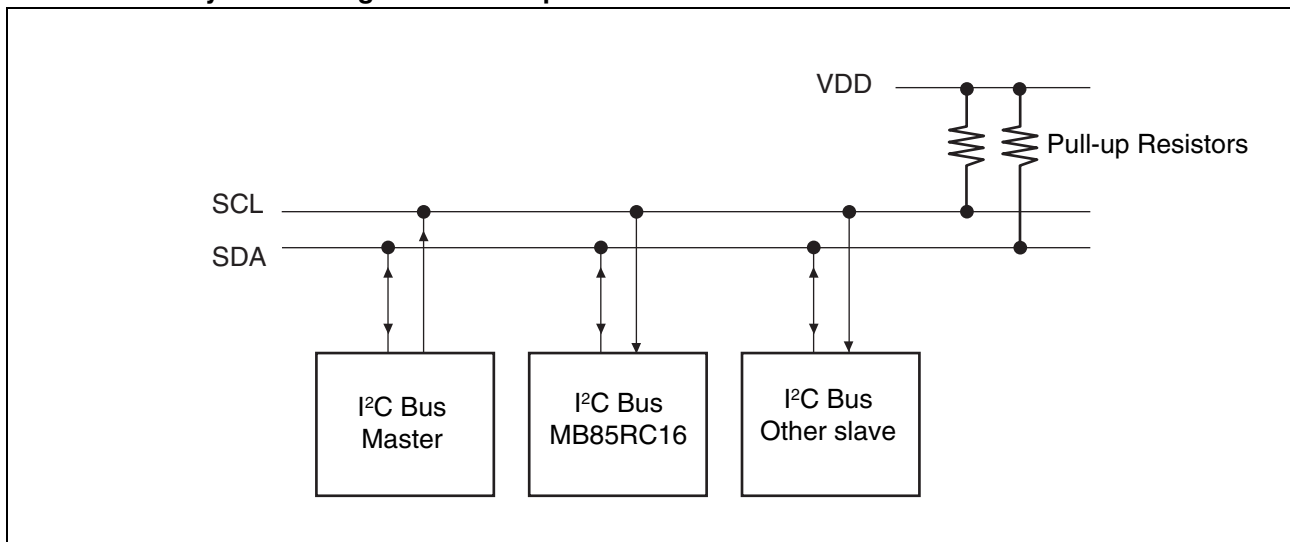

## ■ I<sup>2</sup>C COMMUNICATION PROTOCOL

The I<sup>2</sup>C bus provides communication by two wires only, therefore, the SDA input should change while SCL is the “L” level. However, when starting and stopping the communication sequence, SDA is allowed to change while SCL is the “H” level.

- Start Condition

To start read or write operations by the I<sup>2</sup>C bus, change the SDA input from the “H” level to the “L” level while the SCL input is in the “H” level.

- Stop Condition

To stop the I<sup>2</sup>C bus communication, change the SDA input from the “L” level to the “H” level while the SCL input is in the “H” level. In the reading operation, inputting the stop condition finishes reading and enters the standby state. In the writing operation, inputting the stop condition finishes inputting the rewrite data.

- Start Condition, Stop Condition

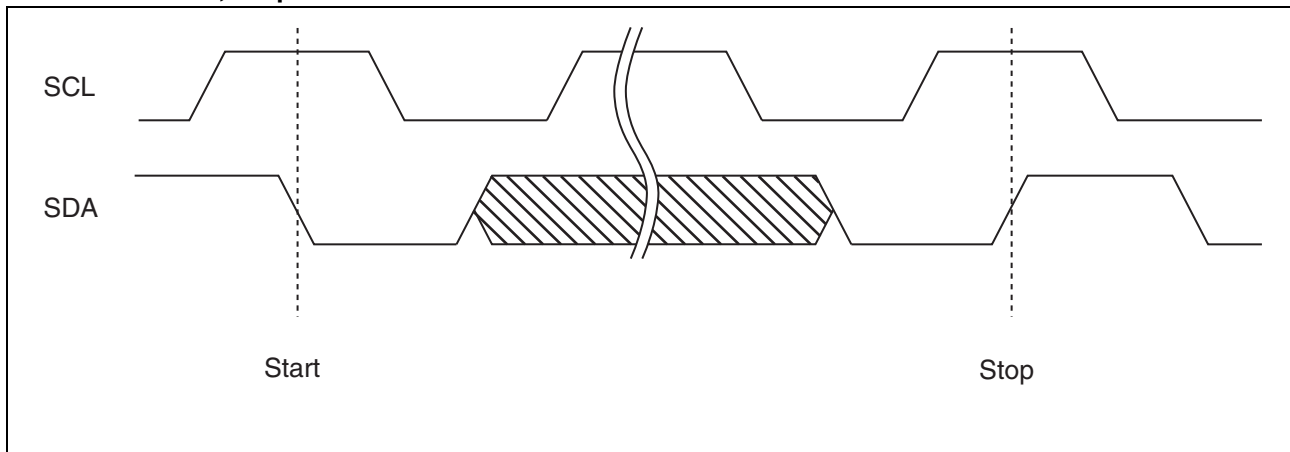

Note : The FRAM device does not need the programming wait time ( $t_{wc}$ ) after issuing the Stop Condition during the write operation.

## ■ ACKNOWLEDGE (ACK)

In the I<sup>2</sup>C bus, serial data including memory address or memory information is sent in units of 8 bits. The acknowledge signal indicates that every 8 bits of the data is successfully sent and received. The receiver side usually outputs the “L” level every time on the 9th SCL clock after every 8 bits are successfully transmitted. On the transmitter side, the bus is temporarily released on this 9th clock to allow the acknowledge signal to be received and checked. During this released period, the receiver side pulls the SDA line down to indicate that the communication works correctly.

If the receiver side receives the stop condition before transmitting the acknowledge “L” level, the read operation ends and the I<sup>2</sup>C bus enters the standby state. If the acknowledge “L” level is not detected, and the Stop condition is not sent, the bus remains in the released state without doing anything.

### • Acknowledge timing overview diagram

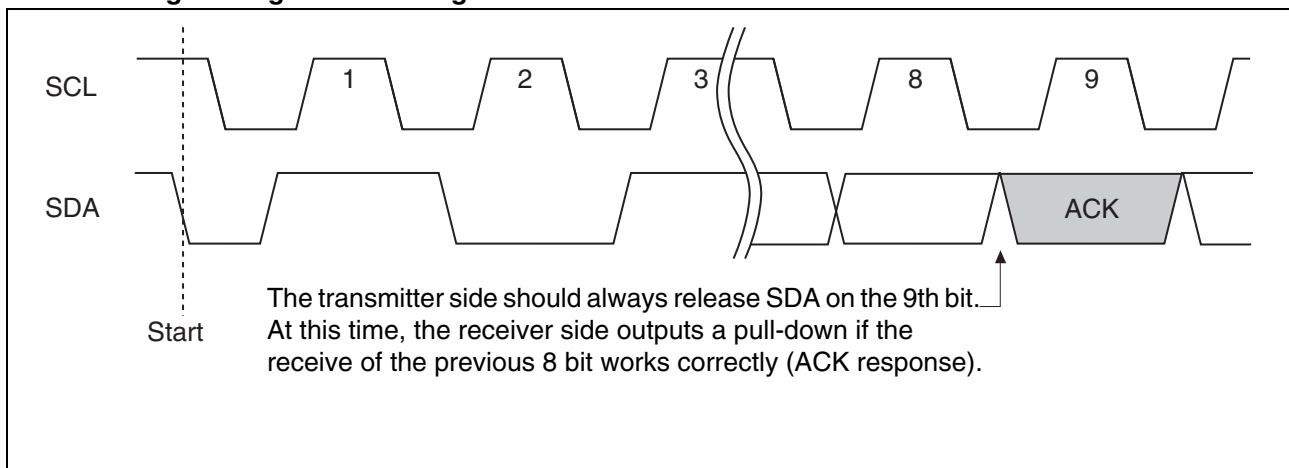

## ■ MEMORY ADDRESS STRUCTURE

The MB85RC16 has the memory address buffer to store the 11-bit information for the memory address.

As for byte write, page write and random read commands, the complete 11-bit memory address is configured by inputting the memory upper address (3 bits) and the memory lower address (8 bits), and saving to the memory address buffer and access to the memory is performed.

As for a current address read command, the complete 11-bit memory address is configured by inputting the memory upper address (3 bits) and by the memory address lower 8-bit which has saved in the memory address buffer, and saving to the memory address buffer and access to the memory is performed.

## ■ DEVICE ADDRESS WORD

Following the start condition, the 8 bit device address word is input. Inputting the device address word decides whether the master or the slave drives the data line. However, the clock is always driven by the master. The device address word (8bits) consists of a device Type code (4bits), memory upper address code (3bits), and a Read/Write code (1bit).

- Device Type Code (4bits)

The upper 4 bits of the device address word are a device type code that identifies the device type, and are fixed at “1010” for the MB85RC16.

- Memory Upper Address Code (3bits)

Following the device type code, the 3 bits of the memory upper address code are input.

The slave address selection is not performed by the external pin setting on this device. These 3 bits are not the setting bits for the slave address, but the upper 3-bit setting bits for the memory address.

- Read/Write Code (1bit)

The 8th bit of the device address word is the R/W (Read/Write) code. When the R/W code is “0” input, a write operation is enabled, and the R/W code is “1” input, a read operation is enabled for the MB85RC16. If the device code is not “1010”, the Read/Write operation is not performed and the standby state is chosen.

## ■ DATA STRUCTURE

The master inputs the device address word (8 bits) following the start condition, and then the slave outputs the Acknowledge "L" level on the ninth bit. After confirming the Acknowledge response, the sequential 8-bit memory lower address is input, to the byte write, page write and random read commands.

As for the current address read command, inputting the memory lower address is not performed, and the address buffer lower 8-bit is used as the memory lower address.

When inputting the memory lower address finishes, the slave outputs the Acknowledge "L" level on the ninth bit again.

Afterwards, the input and the output data continue in 8-bit units, and then the Acknowledge "L" level is output for every 8-bit data.

### • Device Address Word

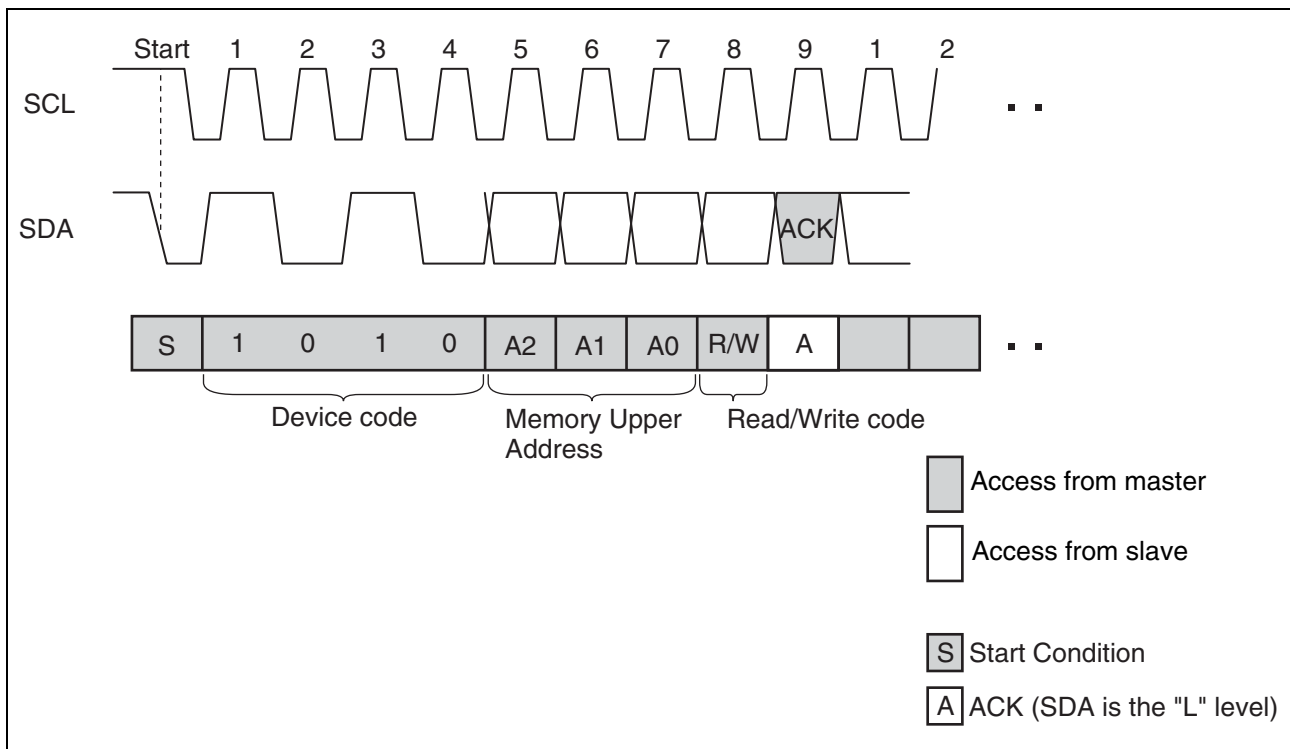

## ■ FRAM ACKNOWLEDGE -- POLLING NOT REQUIRED

The MB85RC16 performs the high speed write operations, so any waiting time for an ACK\* by the acknowledge polling does not occur.

- \*: In E<sup>2</sup>PROM, the Acknowledge Polling is performed as a progress check whether rewriting is executed or not. It is normal to judge by the 9th bit of Acknowledge whether rewriting is performed or not after inputting the start condition and then the device address word (8 bits) during rewriting.

## ■ WRITE PROTECT (WP)

The entire memory array can be write protected by setting the WP pin to the "H" level. When the WP pin is set to the "L" level, the entire memory array will be rewritten. Reading is allowed regardless of the WP pin's "H" level or "L" level.

Do not change the WP signal level during the communication period from the start condition to the stop condition.

Note : The WP pin is pulled down internally to VSS pin, therefore if the WP pin is open, the pin status is detected as the "L" level (write enabled).



## ■ COMMAND

### • Byte Write

If the device address word (R/W "0" input) is sent after the start condition, an ACK responds from the slave. After this ACK, write memory addresses and write data are sent in the same way, and the write ends by generating a stop condition at the end.

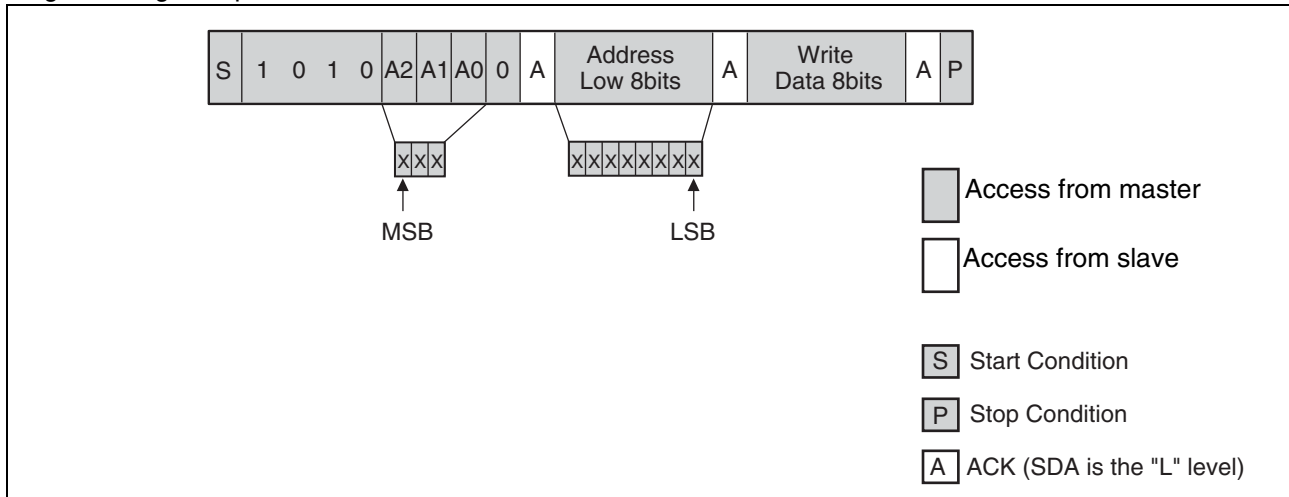

### • Page Write

If data is continuously sent after the following address when the same command (expect stop condition) as Byte Write was sent, a page write is performed. The memory address rolls over to first memory address (000<sub>H</sub>) at the end of the address. Therefore, if more than 2 Kbytes are sent, the data is overwritten in order starting from the start of the memory address that was written first.

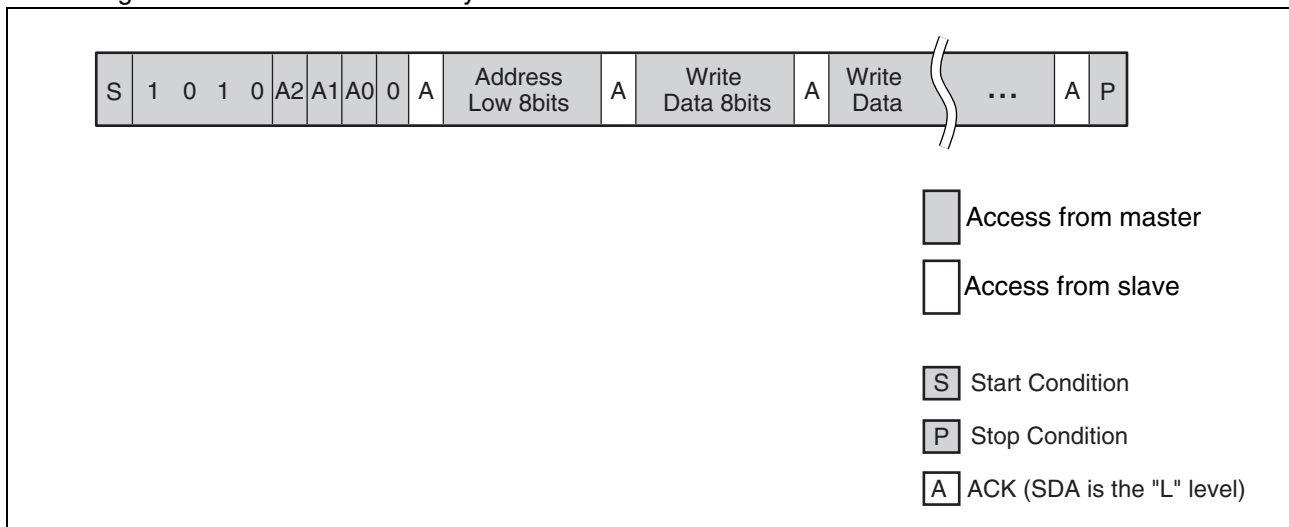

# MB85RC16

- Current Address Read

If the last write or read operation finishes correctly up to the end of stop condition, the memory address that was accessed last remains in the memory address buffer (the length is 11 bits).

When sending this command without turning the power off, it is possible to read from the memory address  $n+1$  which adds 1 to the total 11-bit memory address  $n$ , which consists of the memory upper address 3-bit from the device address word input and the lower 8-bit of the memory address buffer. If the memory address  $n$  is the last address, it is possible to read with rolling over to the head of the memory address (000H). The current address (address that the memory address buffer indicates) is undefined immediately after turning the power on.

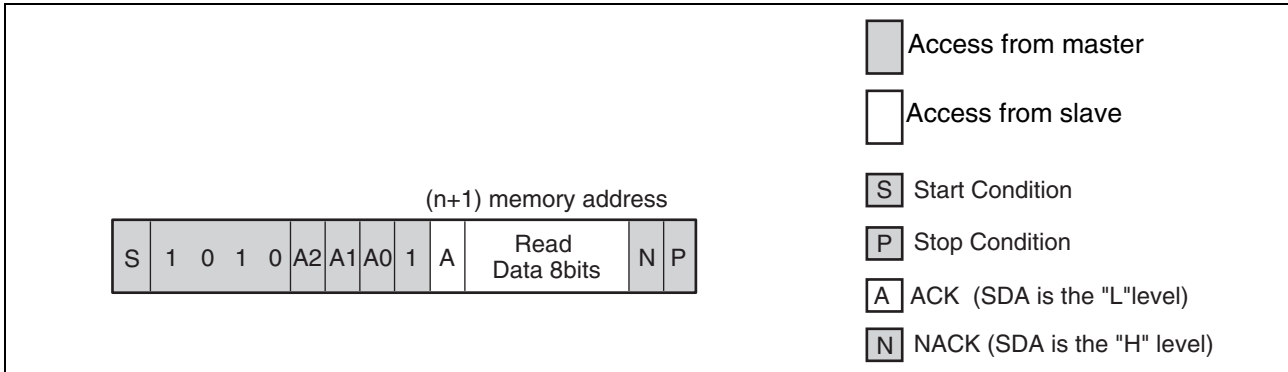

- Random Read

The one byte of data from the memory address as saved in the memory address buffer can be read out synchronously to SCL by specifying the address in the same way as for a write, and then issuing another start condition and sending the Device Address Word (R/W "1" input).

Setting values for the first and the second memory upper address codes should be the same.

The final NACK (SDA is the "H" level) is issued by the receiver that receives the data. In this case, this bit is issued by the master side.

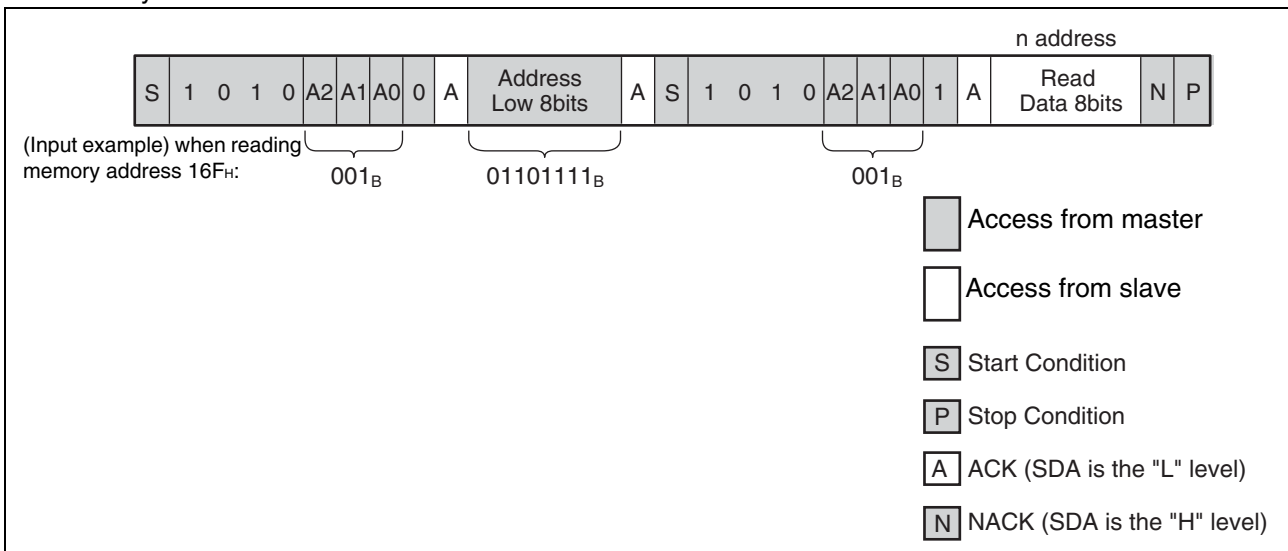

- Sequential Read

Data can be received continuously following the Device address word (R/W "1" input) after specifying the address in the same way as for Random Read. If the read reaches the end of address for the MB85RC16, the read address automatically rolls over to first memory address (000<sub>H</sub>).

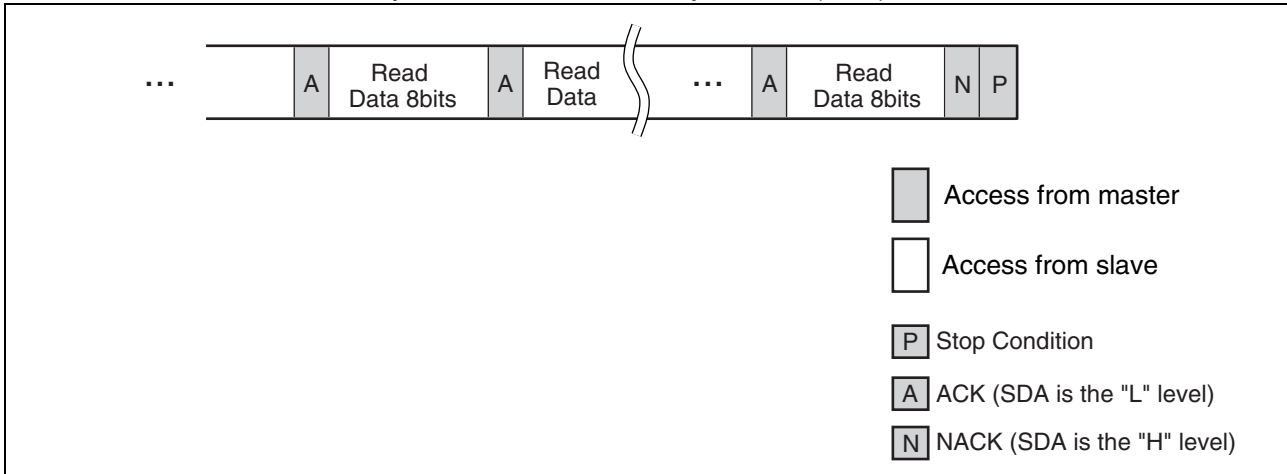

## ■ ABSOLUTE MAXIMUM RATINGS

Parameter	Symbol	Rating		Unit
		Min	Max	
Power supply voltage*	$V_{DD}$	- 0.5	+ 4.0	V
Input voltage*	$V_{IN}$	- 0.5	$V_{DD} + 0.5 (\leq 4.0)$	V
Output voltage*	$V_{OUT}$	- 0.5	$V_{DD} + 0.5 (\leq 4.0)$	V
Ambient temperature	$T_A$	- 40	+ 85	°C
Storage temperature	$T_{stg}$	- 40	+ 125	°C

\*: These parameters are based on the condition that VSS is 0 V.

WARNING: Semiconductor devices can be permanently damaged by application of stress (voltage, current, temperature, etc.) in excess of absolute maximum ratings. Do not exceed these ratings.

## ■ RECOMMENDED OPERATING CONDITIONS

Parameter	Symbol	Value			Unit
		Min	Typ	Max	
Power supply voltage*	$V_{DD}$	2.7	3.3	3.6	V
“H” level input voltage*	$V_{IH}$	$V_{DD} \times 0.8$	—	$V_{DD} + 0.5 (\leq 4.0)$	V
“L” level input voltage*	$V_{IL}$	- 0.5	—	+ 0.6	V
Ambient temperature	$T_A$	- 40	—	+ 85	°C

\*: These parameters are based on the condition that VSS is 0 V.

WARNING: The recommended operating conditions are required in order to ensure the normal operation of the semiconductor device. All of the device's electrical characteristics are warranted when the device is operated within these ranges.

Always use semiconductor devices within their recommended operating condition ranges. Operation outside these ranges may adversely affect reliability and could result in device failure.

No warranty is made with respect to uses, operating conditions, or combinations not represented on the data sheet. Users considering application outside the listed conditions are advised to contact their representatives beforehand.

## ■ ELECTRICAL CHARACTERISTICS

### 1. DC Characteristics

(within recommended operating conditions)

Parameter	Symbol	Condition	Value			Unit
			Min	Typ	Max	
Input leakage current*1	$ I_{LI} $	$V_{IN} = 0\text{ V to }V_{DD}$	—	—	1	$\mu\text{A}$
Output leakage current*2	$ I_{LO} $	$V_{OUT} = 0\text{ V to }V_{DD}$	—	—	1	$\mu\text{A}$
Operating power supply current	$I_{CC}$	SCL = 1 MHz	—	70	100	$\mu\text{A}$
Standby current	$I_{SB}$	SCL, SDA = $V_{DD}$ WP = 0V or $V_{DD}$ or OPEN $T_A = +25\text{ }^\circ\text{C}$	—	0.1	1	$\mu\text{A}$
“L” level output voltage	$V_{OL}$	$I_{OL} = 2\text{ mA}$	—	—	0.4	V
Input resistance for WP pin	$R_{IN}$	$V_{IN} = V_{IL}\text{ (Max)}$	50	—	—	$\text{k}\Omega$
		$V_{IN} = V_{IH}\text{ (Min)}$	1	—	—	$\text{M}\Omega$

\*1: Applicable pin: SCL,SDA

\*2: Applicable pin: SDA

## 2. AC Characteristics

(within recommended operating conditions)

Parameter	Symbol	Value				Unit
		STANDARD MODE		FAST MODE		
		Min	Max	Min	Max	
SCL clock frequency	F <sub>SCL</sub>	0	400	0	1000	kHz
Clock high time	T <sub>HIGH</sub>	600	—	400	—	ns
Clock low time	T <sub>LOW</sub>	1300	—	600	—	ns
SCL/SDA rise time	T <sub>r</sub>	—	300	—	300	ns
SCL/SDA fall time	T <sub>f</sub>	—	300	—	100	ns
Start condition hold	T <sub>HD:STA</sub>	600	—	250	—	ns
Start condition setup	T <sub>SU:STA</sub>	600	—	250	—	ns
SDA input hold	T <sub>HD:DAT</sub>	0	—	0	—	ns
SDA input setup	T <sub>SU:DAT</sub>	100	—	100	—	ns
SDA output hold	T <sub>DH:DAT</sub>	0	—	0	—	ns
Stop condition setup	T <sub>SU:STO</sub>	600	—	250	—	ns
SDA output access after SCL fall	T <sub>AA</sub>	—	900	—	550	ns
Pre-charge time	T <sub>BUF</sub>	1300	—	500	—	ns
Noise suppression time constant on SCL, SDA	T <sub>SP</sub>	—	50	—	50	ns

AC characteristics were measured under the following measurement conditions.

- Power supply voltage : 2.7 V to 3.6 V
- Operating temperature : - 40 °C to + 85 °C
- Input voltage amplitude : 0.3 V to 2.7 V
- Input rise time : 5 ns
- Input fall time : 5 ns
- Input judge level : V<sub>DD</sub>/2
- Output judge level : V<sub>DD</sub>/2

### 3. AC Timing Definitions

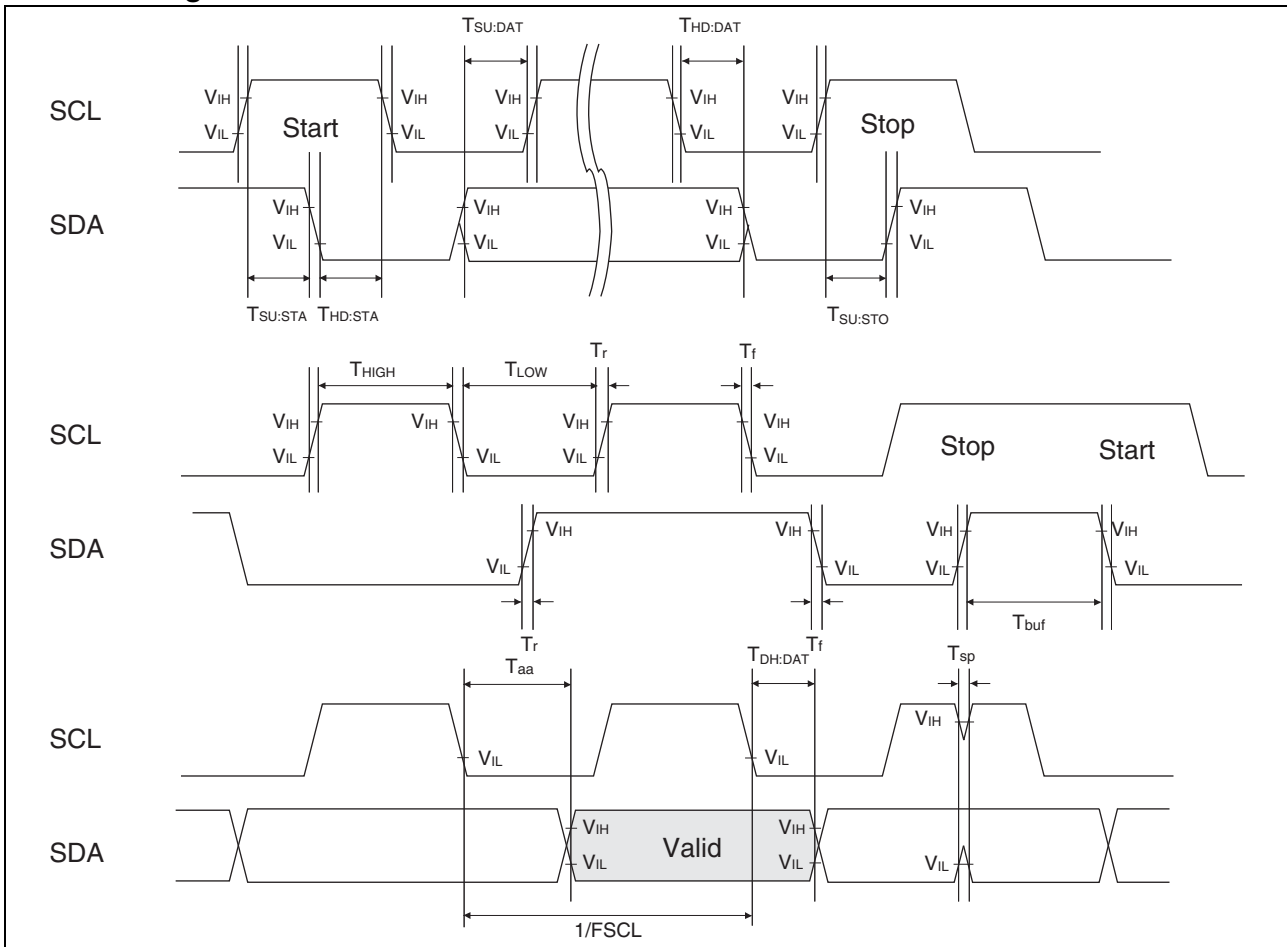

### 4. Pin capacitance

Parameter	Symbol	Conditions	Value			Unit
			Min	Typ	Max	
I/O capacitance	$C_{I/O}$	$V_{DD} = V_{IN} = V_{OUT} = 0V$ , $f = 1\text{ MHz}$ , $T_A = +25\text{ }^\circ\text{C}$	—	—	15	pF
Input capacitance	$C_{IN}$		—	—	15	pF

### 5. AC Test Load Circuit

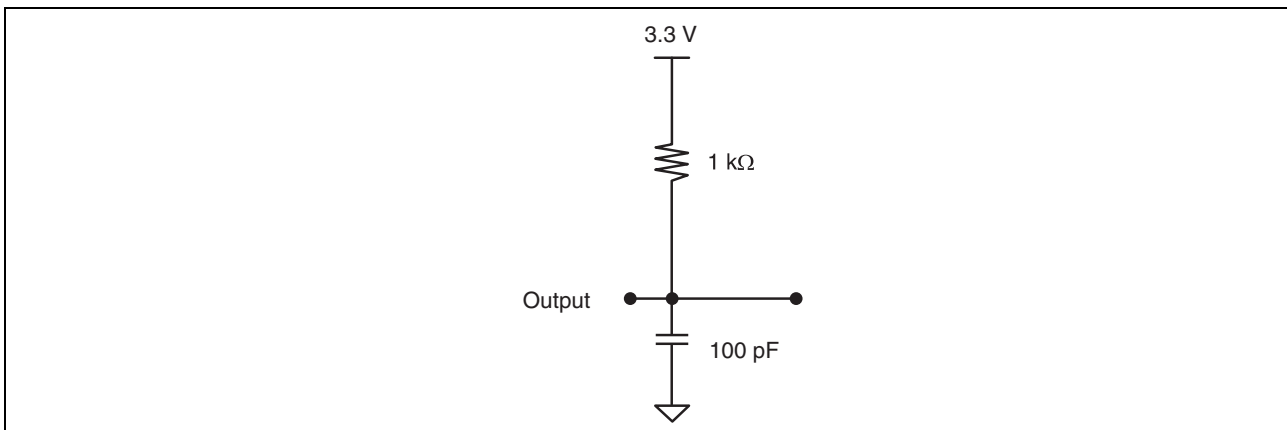

## POWER ON SEQUENCE

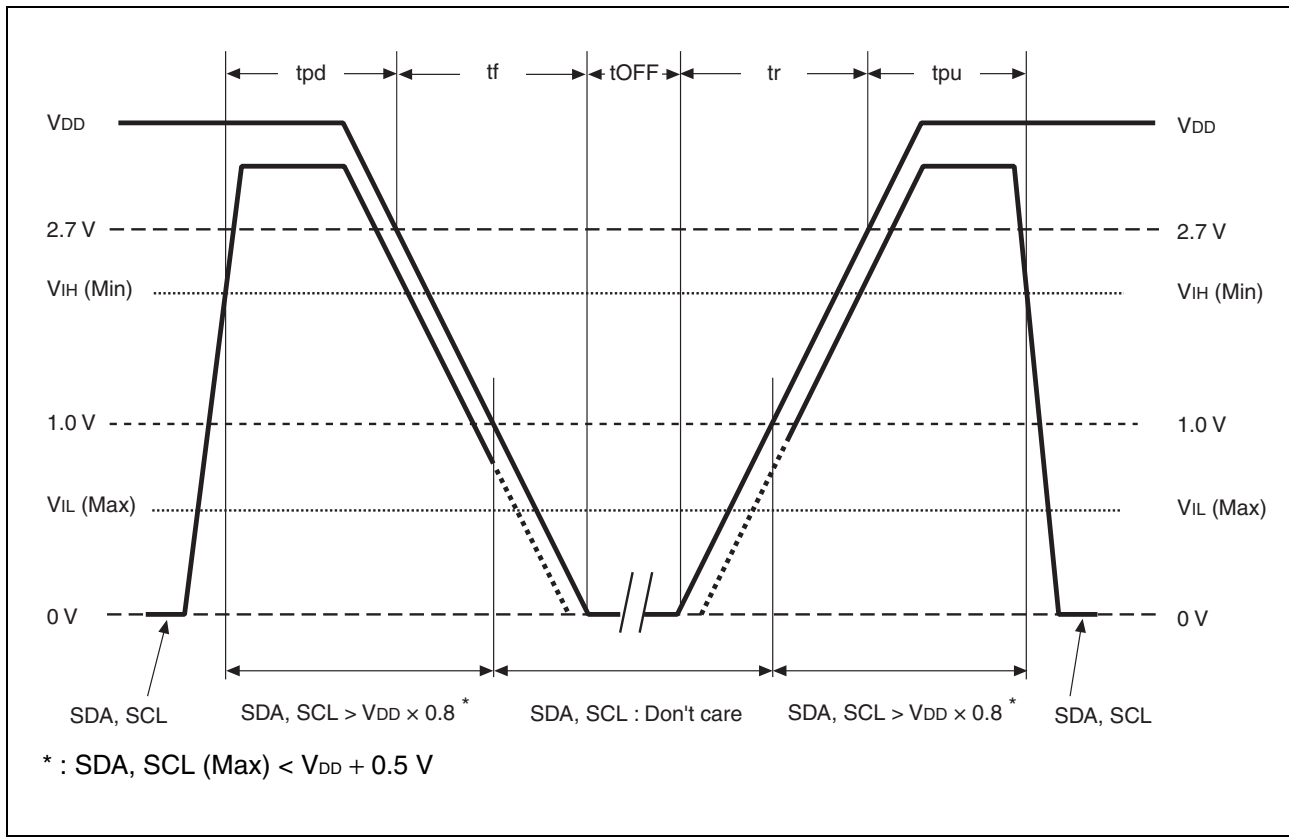

Parameter	Symbol	Value		Unit
		Min	Max	
SDA, SCL level hold time during power down	tpd	85	—	ns
SDA, SCL level hold time during power up	tpu	85	—	ns
Power supply rise time	tr	0.01	50	ms
Power supply fall time	tf	0.01	50	ms
Power off time	tOFF	50	—	ms

## NOTES ON USE

- Data written before performing IR reflow is not guaranteed after IR reflow.
- V<sub>DD</sub> is required to be rising from 0 V because turning the power on from an intermediate level may cause malfunctions, when the power is turned on.



## ■ ORDERING INFORMATION

Part number	Package	Remarks
MB85RC16PNF-G-JNE1	8-pin, plastic SOP (FPT-8P-M02)	
MB85RC16PNF-G-JNERE1	8-pin, plastic SOP (FPT-8P-M02)	Embossed Carrier tape

# MB85RC16

## PACKAGE DIMENSION

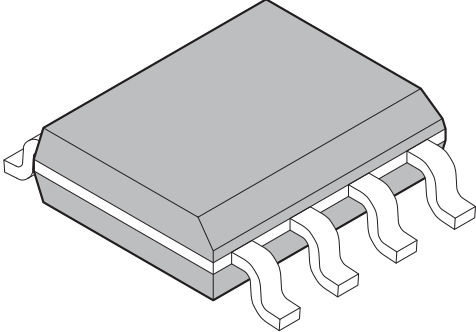
<p>8-pin plastic SOP</p>  <p>(FPT-8P-M02)</p>	Lead pitch	1.27 mm
	Package width × package length	3.9 mm × 5.05 mm
	Lead shape	Gullwing
	Sealing method	Plastic mold
	Mounting height	1.75 mm MAX
	Weight	0.06 g

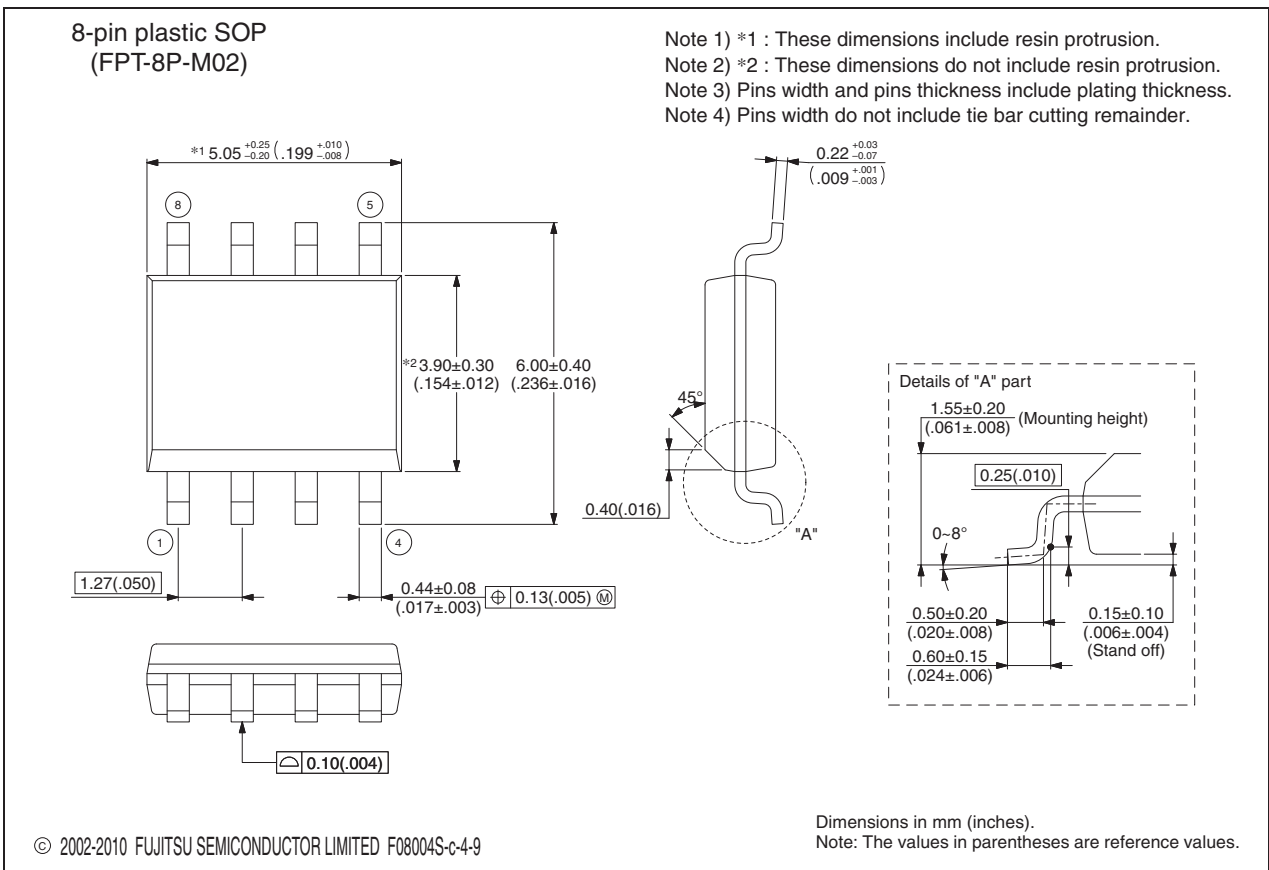

Please check the latest package dimension at the following URL.  
<http://edevice.fujitsu.com/package/en-search/>

**MEMO**

## FUJITSU SEMICONDUCTOR LIMITED

Nomura Fudosan Shin-yokohama Bldg. 10-23, Shin-yokohama 2-Chome,  
Kohoku-ku Yokohama Kanagawa 222-0033, Japan

Tel: +81-45-415-5858

<http://jp.fujitsu.com/fsl/en/>

*For further information please contact:*

### North and South America

FUJITSU SEMICONDUCTOR AMERICA, INC.

1250 E. Arques Avenue, M/S 333

Sunnyvale, CA 94085-5401, U.S.A.

Tel: +1-408-737-5600 Fax: +1-408-737-5999

<http://us.fujitsu.com/micro/>

### Asia Pacific

FUJITSU SEMICONDUCTOR ASIA PTE. LTD.

151 Lorong Chuan,

#05-08 New Tech Park 556741 Singapore

Tel : +65-6281-0770 Fax : +65-6281-0220

<http://sg.fujitsu.com/semiconductor/>

### Europe

FUJITSU SEMICONDUCTOR EUROPE GmbH

Pittlerstrasse 47, 63225 Langen, Germany

Tel: +49-6103-690-0 Fax: +49-6103-690-122

<http://emea.fujitsu.com/semiconductor/>

FUJITSU SEMICONDUCTOR SHANGHAI CO., LTD.

Rm. 3102, Bund Center, No.222 Yan An Road (E),

Shanghai 200002, China

Tel : +86-21-6146-3688 Fax : +86-21-6335-1605

<http://cn.fujitsu.com/fss/>

### Korea

FUJITSU SEMICONDUCTOR KOREA LTD.

902 Kosmo Tower Building, 1002 Daechi-Dong,

Gangnam-Gu, Seoul 135-280, Republic of Korea

Tel: +82-2-3484-7100 Fax: +82-2-3484-7111

<http://kr.fujitsu.com/fsk/>

FUJITSU SEMICONDUCTOR PACIFIC ASIA LTD.

10/F., World Commerce Centre, 11 Canton Road,

Tsimshatsui, Kowloon, Hong Kong

Tel : +852-2377-0226 Fax : +852-2376-3269

<http://cn.fujitsu.com/fsp/>

Specifications are subject to change without notice. For further information please contact each office.

### All Rights Reserved.

The contents of this document are subject to change without notice.

Customers are advised to consult with sales representatives before ordering.

The information, such as descriptions of function and application circuit examples, in this document are presented solely for the purpose of reference to show examples of operations and uses of FUJITSU SEMICONDUCTOR device; FUJITSU SEMICONDUCTOR does not warrant proper operation of the device with respect to use based on such information. When you develop equipment incorporating the device based on such information, you must assume any responsibility arising out of such use of the information.

FUJITSU SEMICONDUCTOR assumes no liability for any damages whatsoever arising out of the use of the information.

Any information in this document, including descriptions of function and schematic diagrams, shall not be construed as license of the use or exercise of any intellectual property right, such as patent right or copyright, or any other right of FUJITSU SEMICONDUCTOR or any third party or does FUJITSU SEMICONDUCTOR warrant non-infringement of any third-party's intellectual property right or other right by using such information. FUJITSU SEMICONDUCTOR assumes no liability for any infringement of the intellectual property rights or other rights of third parties which would result from the use of information contained herein.

The products described in this document are designed, developed and manufactured as contemplated for general use, including without limitation, ordinary industrial use, general office use, personal use, and household use, but are not designed, developed and manufactured as contemplated (1) for use accompanying fatal risks or dangers that, unless extremely high safety is secured, could have a serious effect to the public, and could lead directly to death, personal injury, severe physical damage or other loss (i.e., nuclear reaction control in nuclear facility, aircraft flight control, air traffic control, mass transport control, medical life support system, missile launch control in weapon system), or (2) for use requiring extremely high reliability (i.e., submersible repeater and artificial satellite).

Please note that FUJITSU SEMICONDUCTOR will not be liable against you and/or any third party for any claims or damages arising in connection with above-mentioned uses of the products.

Any semiconductor devices have an inherent chance of failure. You must protect against injury, damage or loss from such failures by incorporating safety design measures into your facility and equipment such as redundancy, fire protection, and prevention of over-current levels and other abnormal operating conditions.

Exportation/release of any products described in this document may require necessary procedures in accordance with the regulations of the Foreign Exchange and Foreign Trade Control Law of Japan and/or US export control laws.

The company names and brand names herein are the trademarks or registered trademarks of their respective owners.

Edited: Sales Promotion Department

## X-ON Electronics

Largest Supplier of Electrical and Electronic Components

*Click to view similar products for [F-RAM](#) category:*

*Click to view products by [Fujitsu](#) manufacturer:*

Other Similar products are found below :

[FM25CL64B-DGTR](#) [CY15B128Q-SXE](#) [CY15B256Q-SXAT](#) [MB85RC64APNF-G-JNE1](#) [MB85RS128BPNF-G-JNE1](#) [MB85R4002ANC-GE1](#)  
[FM25640B-G](#) [FM25640B-GTR](#) [FM25V02A-DGQ](#) [FM24V05-GTR](#) [CY15B104Q-LHXIT](#) [CY15B104Q-SXIT](#) [FM24V01A-GTR](#)  
[FM24V02A-GTR](#) [FM24W256-GTR](#) [FM25V02A-DGTR](#) [FM28V020-SGTR](#) [FM28V202A-TG](#) [CY15B104Q-LHXI](#) [CY15V108QN-20LPXI](#)  
[CY15V108QN-40LPXI](#) [CY15B104QSN-108LPXI](#) [CY15B104QSN-108SXI](#) [CY15B104Q-SXI](#) [CY15V104QI-20LPXC](#) [CY15B108QI-](#)  
[20LPXC](#) [CY15B108QI-20LPXI](#) [CY15B108QN-20LPXC](#) [CY15B108QN-40SXI](#) [CY15V104QSN-108LPXI](#) [CY15V104QSN-108SXI](#)  
[CY15B108QN-40LPXI](#) [CY15V108QI-20LPXC](#) [CY15V108QN-20LPXC](#) [FM16W08-SG](#) [FM1808B-SG](#) [FM18W08-SG](#) [FM22L16-55-TG](#)  
[FM24C04B-G](#) [FM24C04B-GTR](#) [FM24C16B-GTR](#) [FM24C64B-G](#) [FM24CL04B-G](#) [FM24CL04B-GTR](#) [FM24CL16B-DG](#) [FM24CL16B-GTR](#)  
[FM24CL64B-G](#) [FM24CL64B-GTR](#) [FM24V05-G](#) [FM24V10-G](#)