

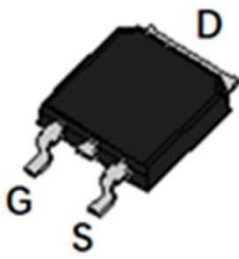
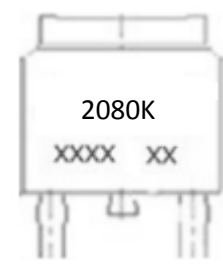
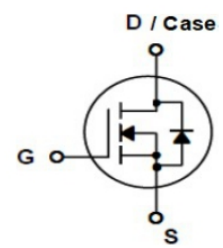

Description

<p>General Description</p> <p>The 2080K uses advanced trench technology to provide excellent RDS(ON), low gate charge. This device is suitable for use in Load Switch, PWM Application, Power management and general purpose applications.</p>	<p>Features</p> <ul style="list-style-type: none"> ➤ Extremely Low RDS(on): ➤ Typ. RDS(on) = 3.4mΩ @ VGS=4.5 V, Id=30 A ➤ Good stability and uniformity ➤ 100% avalanche tested ➤ Excellent package for good heat dissipation 	
 <p>TO-252(DPAK) top view</p>	 <p>Marking and pin Assignment</p>	 <p>Schematic Diagram</p>

Absolute Maximum Ratings (T_C=25°C unless otherwise specified)

Symbol	Parameter	Max.	Units
V _{DS}	Drain-Source Voltage	20	V
V _{GS}	Gate-Source Voltage	±12	V
I _D	Continuous Drain Current	T _C = 25°C	80
		T _C = 100°C	58
I _{DM}	Pulsed Drain Current ^{note1}	240	A
E _{AS}	Single Pulsed Avalanche Energy ^{note2}	196	mJ
P _D	Power Dissipation	T _C = 25°C	88
		Derate above 25°C	0.54
R _{θJC}	Thermal Resistance, Junction to Case	1.85	°C/W
T _J , T _{STG}	Operating and Storage Temperature Range	-55 to +150	°C



富满微电子集团股份有限公司

FINE MADE MICROELECTRONICS GROUP CO., LTD.

2080K (File No.: S&CIC2028)

20V N-channel enhancement mode MOSFET

Electrical Characteristics (T_J=25°C unless otherwise specified)

Symbol	Parameter	Conditions	Min	Typ	Max	Unit
On/Off States						
B _V DSS	Drain-Source Breakdown Voltage	V _{GS} = 0 V, I _D = 250 μA	20			V
I _{DSS}	Zero Gate Voltage Drain Current	V _{DS} = 24 V, V _{GS} = 0 V			1	μA
I _{GSSF}	Gate Leakage Current, Forward	V _{GS} = 12 V, V _{DS} = 0 V			100	nA
I _{GSSR}	Gate Leakage Current, Reverse	V _{GS} = -12 V, V _{DS} = 0 V			-100	nA
V _{GS(th)}	Gate Threshold Voltage	V _{DS} =V _{GS} , I _D =250μA	0.4	0.8	1.2	V
R _{DS(ON)}	Drain-Source On-State Resistance	V _{GS} =4.5V, I _D =30A		3.4	4.5	mΩ
		V _{GS} =2.5V, I _D =20A		4.2	6.0	mΩ
Dynamic Characteristics						
C _{iss}	Input Capacitance	V _{DS} =10V, V _{GS} =0V, f=1.0MHz		2560		pF
C _{oss}	Output Capacitance			368		pF
C _{rss}	Reverse Transfer Capacitance			356		pF
Switching Times						
t _{d(on)}	Turn-on Delay Time	V _{DS} =10V, I _D =30A, V _{GS} =4.5V, R _G =1.8Ω (Note 3, 4)		7.8		nS
t _r	Turn-on Rise Time			30		nS
t _{d(off)}	Turn-Off Delay Time			50		nS
t _f	Turn-Off Fall Time			42		nS
Q _g	Total Gate Charge		V _{DS} =10V, I _D =30A, V _{GS} =4.5V		38	
Q _{gs}	Gate-Source Charge	(Note 3, 4)		2.9		nC
Q _{gd}	Gate-Drain Charge			15		nC
Source-Drain Diode Characteristics						
I _S	Maximum Continuous Drain-Source Diode Forward Current			80	A	I _S
I _{SM}	Maximum Pulsed Drain-Source Diode Forward Current			240	A	I _{SM}
V _{SD}	Diode Forward Voltage	V _{GS} = 0 V, I _S = 30 A		1.2	V	V _{SD}
T _{rr}	Reverse recovery time	I _F =30A, di/dt=100A/μS	18		ns	T _{rr}
Q _{rr}	Reverse recovery charge		8		nC	Q _{rr}

Notes:

1. Repetitive Rating : Pulse width limited by maximum junction temperature
2. L = 0.5 mH, V_G=4.5V, V_{DD} = 15V, R_G = 25 Ω, Starting T_J = 25° C
3. I_{SD} ≤ 30A, di/dt = 100A/us, V_{DD} ≤ B_VDSS, Starting T_J =25° C
4. Pulse Test : Pulse width ≤ 300us, Duty cycle ≤ 2%
5. Essentially independent of operating temperature



2080K (File No.: S&CIC2028) 20V N-channel enhancement mode MOSFET

TYPICAL ELECTRICAL AND THERMAL CHARACTERISTICS (Curves)

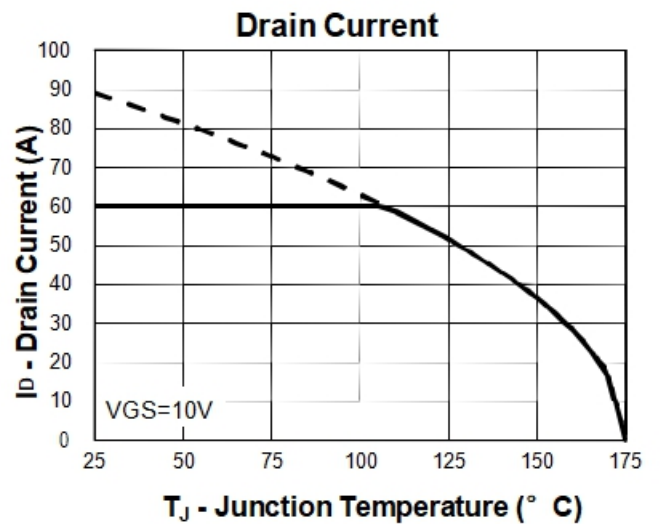
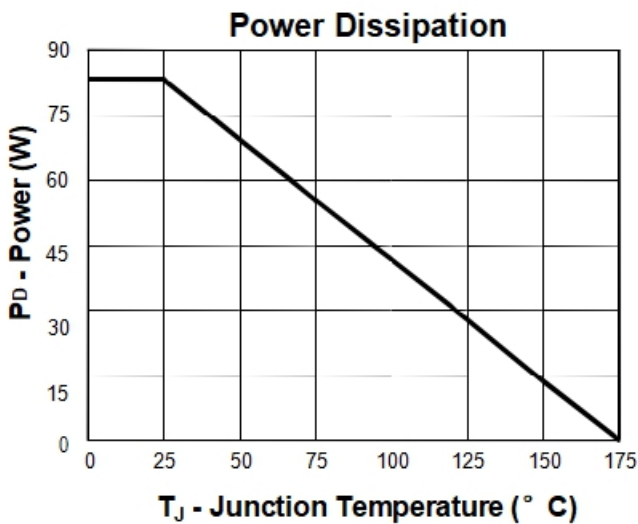
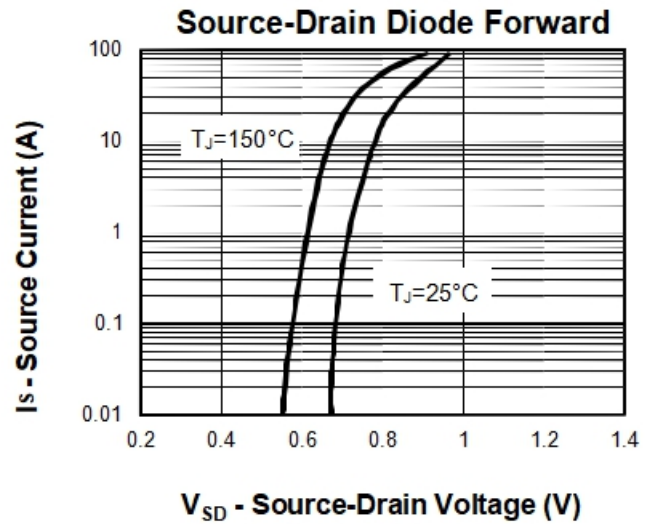
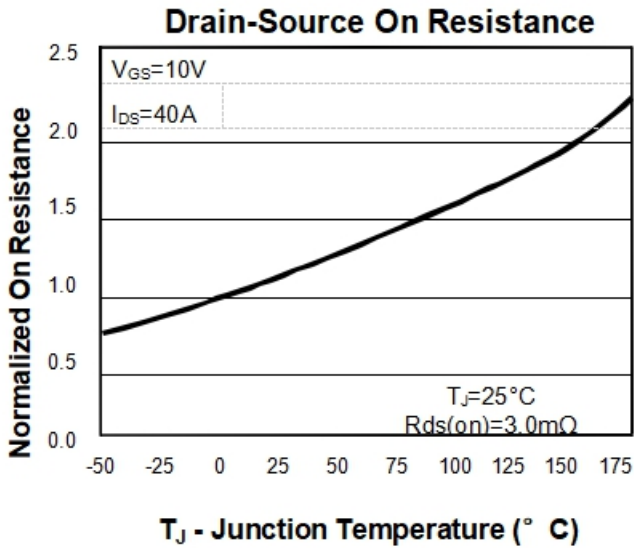
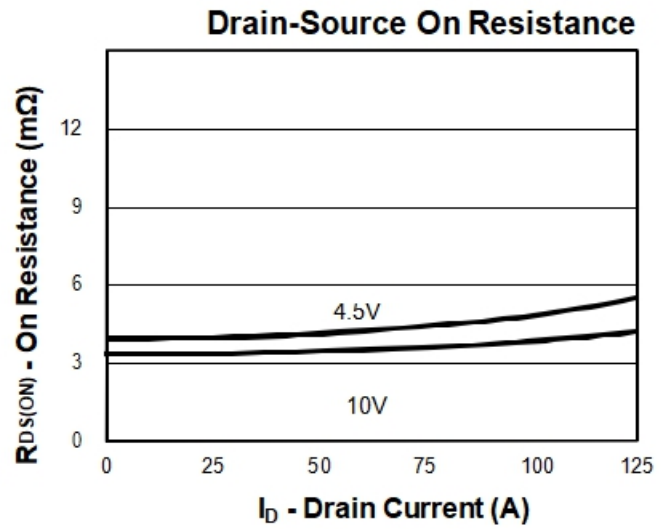
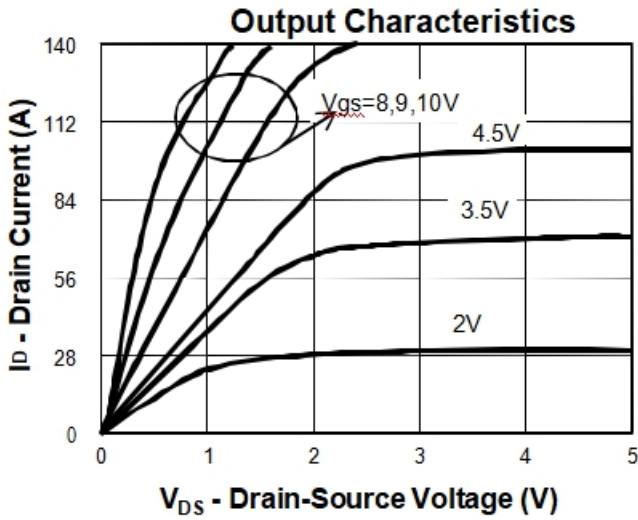



Capacitance

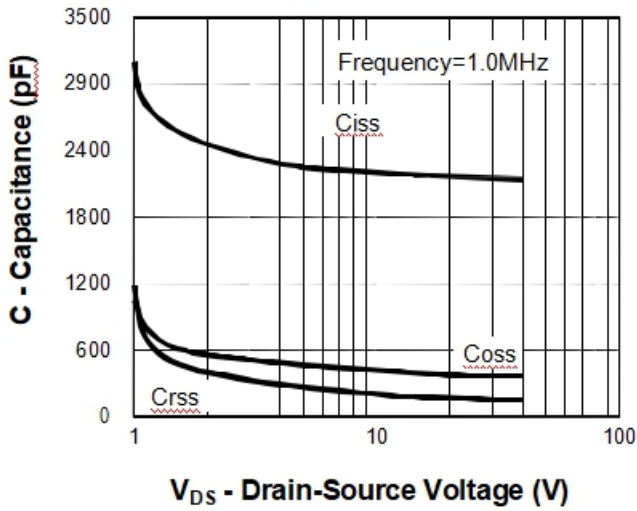

Gate Charge

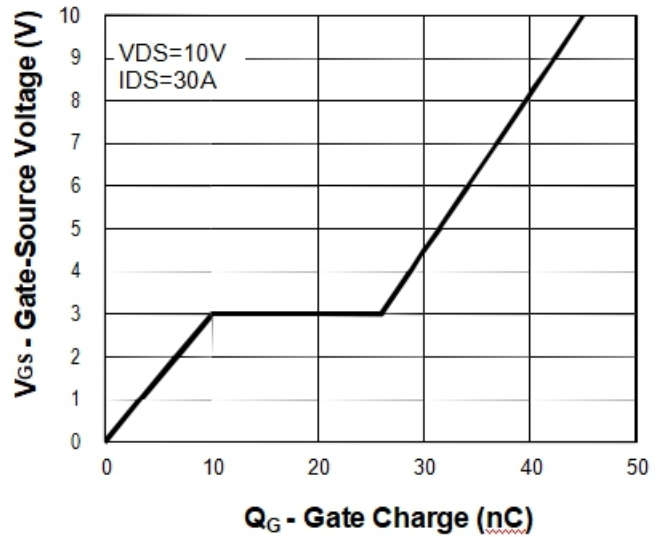

Safe Operation Area

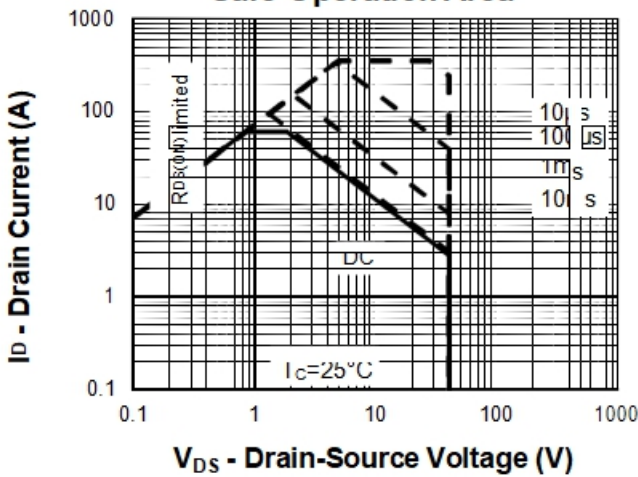

Drain Current

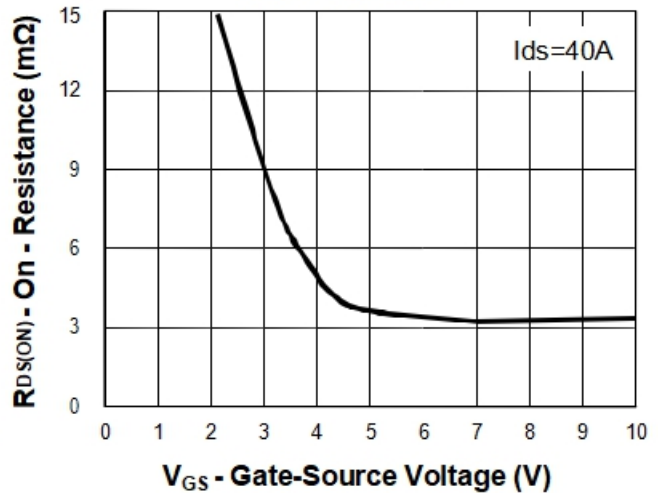

Thermal Transient Impedance

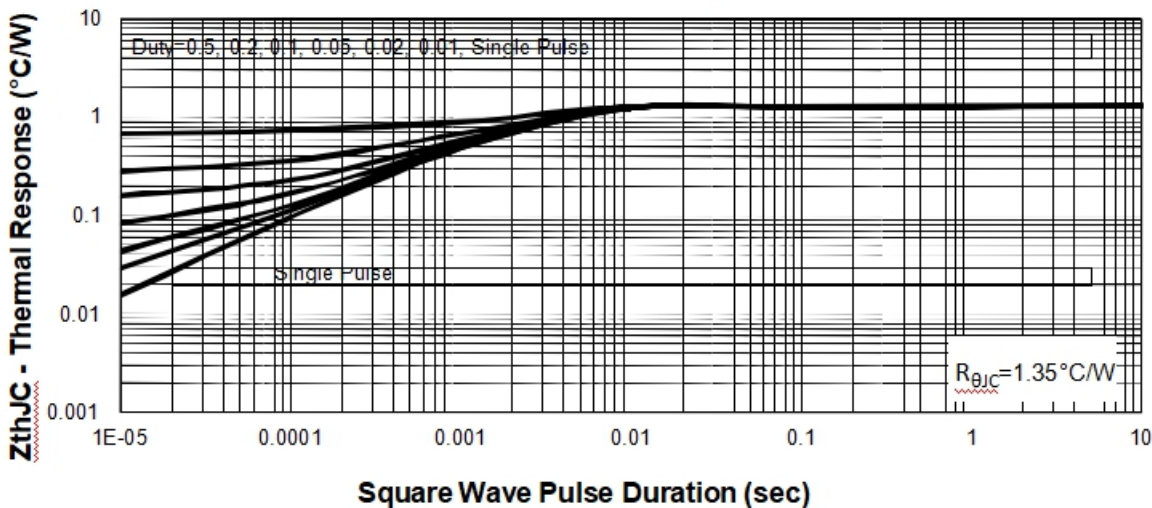

Test



Circuit

EAS Test Circuits:

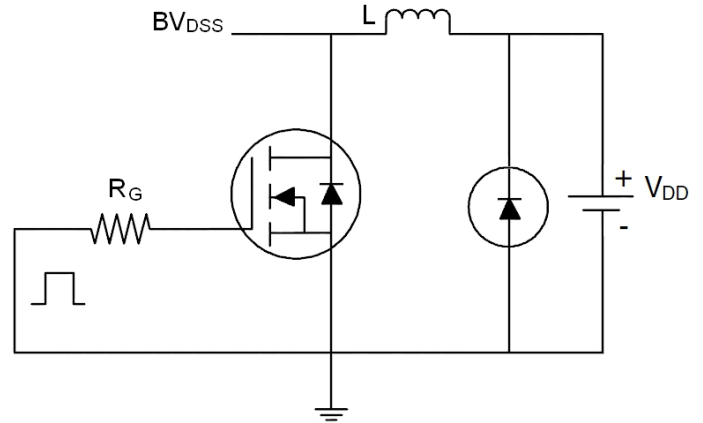
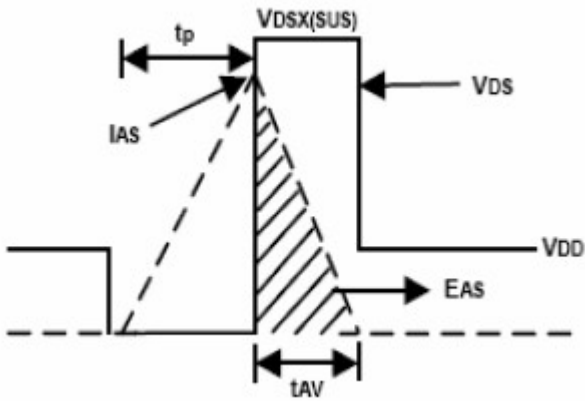

Gate Charge Test Circuit:

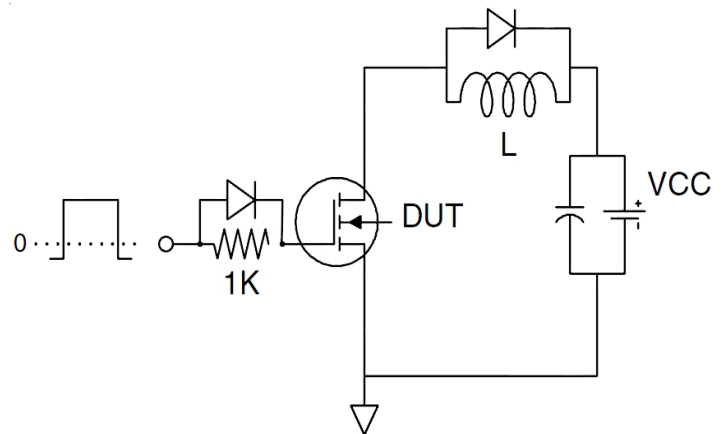
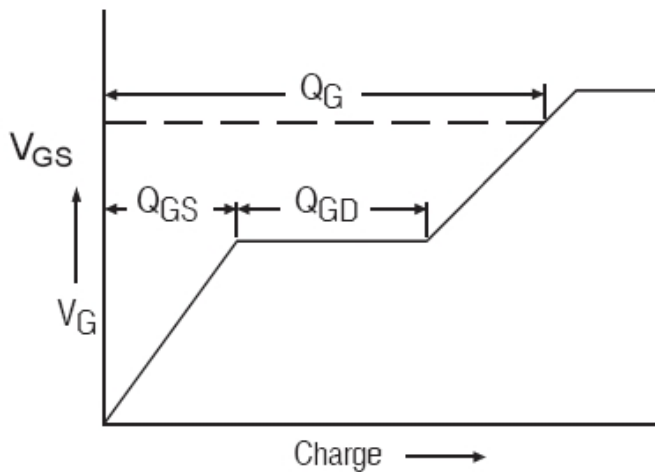

Switch Time Test Circuit:

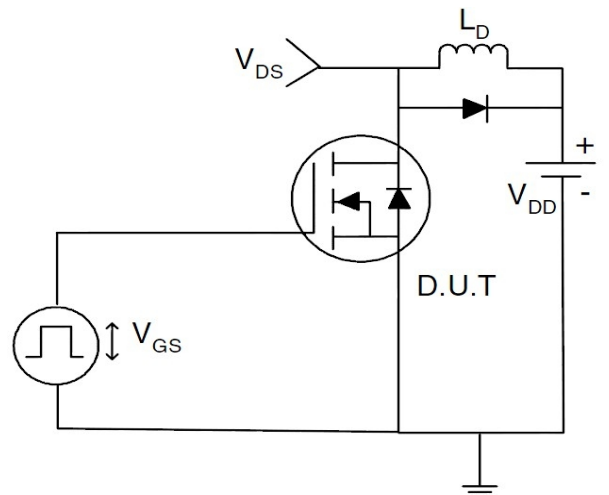
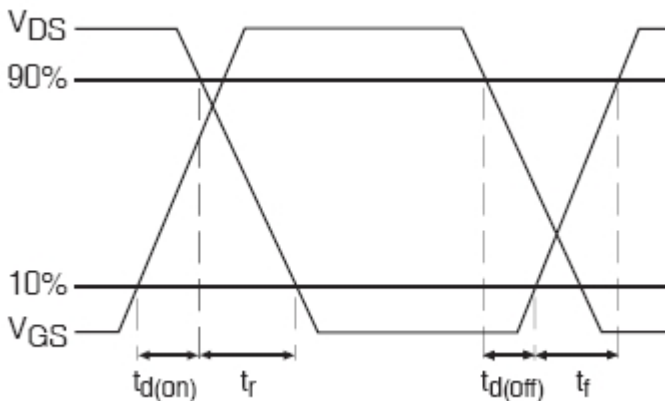



TO-252 Package Information

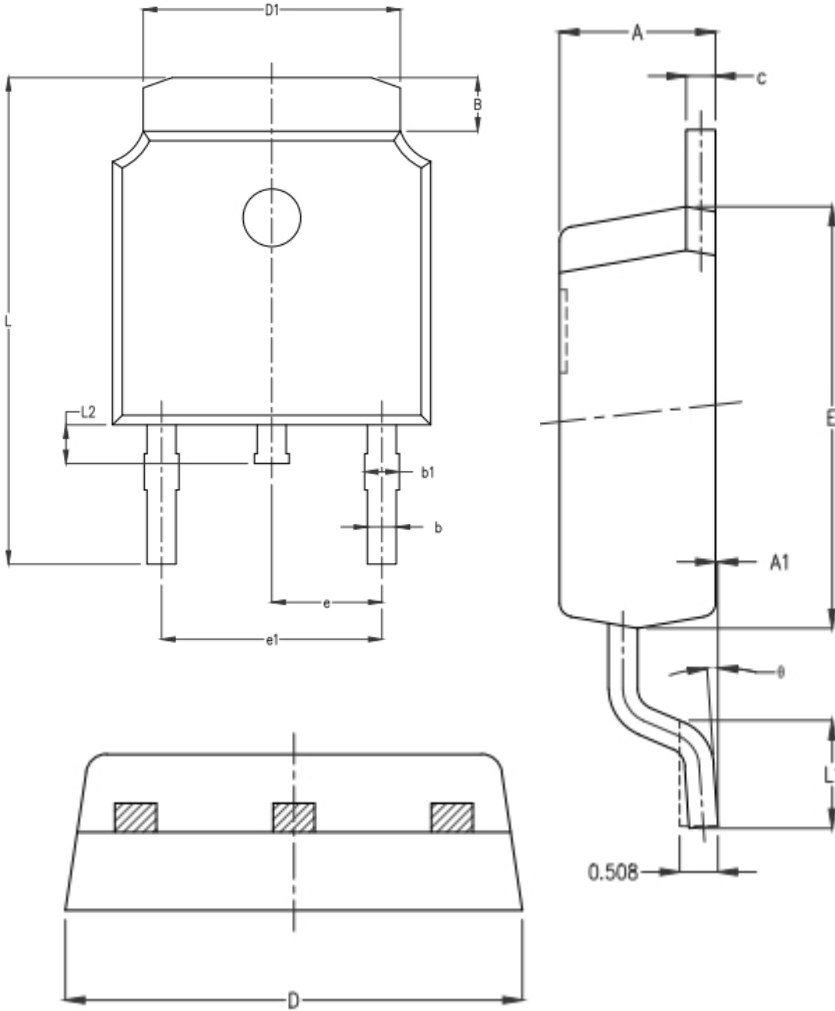

SYMBOL	MILLIMETER		
	MIN	NOM	MAX
A	2.15	2.25	2.35
A1	0.00	0.06	0.12
B	0.96	1.11	1.26
b	0.59	0.69	0.79
b1	0.69	0.81	0.93
c	0.34	0.42	0.50
D	6.45	6.60	6.75
D1	5.23	5.33	5.43
E	5.95	6.10	6.25
e	2.286TYP.		
e1	4.47	4.57	4.67
L	9.90	10.10	10.30
L1	1.40	1.55	1.70
L2	0.60	0.80	1.00
θ	0°	4°	8°

X-ON Electronics

Largest Supplier of Electrical and Electronic Components

Click to view similar products for [MOSFET](#) category:

Click to view products by [Fuman](#) manufacturer:

Other Similar products are found below :

[IRFD120](#) [JANTX2N5237](#) [BUK455-60A/B](#) [MIC4420CM-TR](#) [VN1206L](#) [NDP4060](#) [SI4482DY](#) [IPS70R2K0CEAKMA1](#) [SQD23N06-31L-GE3](#)
[TK16J60W,S1VQ\(O](#) [2SK2614\(TE16L1,Q\)](#) [DMN1017UCP3-7](#) [DMN1053UCP4-7](#) [SQJ469EP-T1-GE3](#) [NTE2384](#) [DMC2700UDMQ-7](#)
[DMN2080UCB4-7](#) [DMN61D9UWQ-13](#) [US6M2GTR](#) [DMN31D5UDJ-7](#) [DMP22D4UFO-7B](#) [DMN1006UCA6-7](#) [DMN16M9UCA6-7](#)
[STF5N65M6](#) [IRF40H233XTMA1](#) [STU5N65M6](#) [DMN6022SSD-13](#) [DMN13M9UCA6-7](#) [DMTH10H4M6SPS-13](#) [DMN2990UFB-7B](#)
[IPB80P04P405ATMA2](#) [2N7002W-G](#) [MCAC30N06Y-TP](#) [MCQ7328-TP](#) [BXP7N65D](#) [BXP4N65F](#) [AOL1454G](#) [WMJ80N60C4](#) [BXP2N20L](#)
[BXP2N65D](#) [BXT1150N10J](#) [BXT1700P06M](#) [TSM60NB380CP](#) [ROG](#) [RQ7L055BGTCR](#) [DMNH15H110SK3-13](#) [SLF10N65ABV2](#)
[BSO203SP](#) [BSO211P](#) [IPA60R230P6](#) [IPA60R460CE](#)