

USB Dedicated Charging Port Controller

1 FEATURES

- Supports USB DCP Shorting D+ Line to D- Line per USB Battery Charging Specification, Revision 1.2 (BC1.2)
- Supports Shorted Mode D+ Line to D- Line per Chinese Telecommunication Industry Standard YD/T 1591-2009
- Supports USB DCP Applying 2.7 V on D+ Line and 2.7 V on D- Line
- Dual USB Port Controller, FM5888C
- Single USB Port Controller, FM5887C
- Operating Voltage Range: 4.5V to 5.5V
- FM5888C is available in SOT23-6 package
- FM5887C is available in SOT23-5 package

2 APPLICATIONS

- Vehicle USB Power Charger
- AC-DC Adapter with USB Port
- Other USB Charger

3 DESCRIPTION

The FM5887C and FM5888C are USB dedicated charging port (DCP) controllers. An auto-detect feature monitors USB data line voltage, and automatically provides the correct electrical signatures on the data lines to charge compliant devices among the following dedicated charging schemes:

1. Divider DCP, required to apply 2.7 V and 2.7 V on the D+ and D- Lines respectively
2. BC1.2 DCP, required to short the D+ Line to the D- Line
3. Chinese Telecom Standard YD/T 1591-2009 Shorted Mode, required to short the D+ Line to the D- Line

4 SIMPLIFIED APPLICATION DIAGRAM

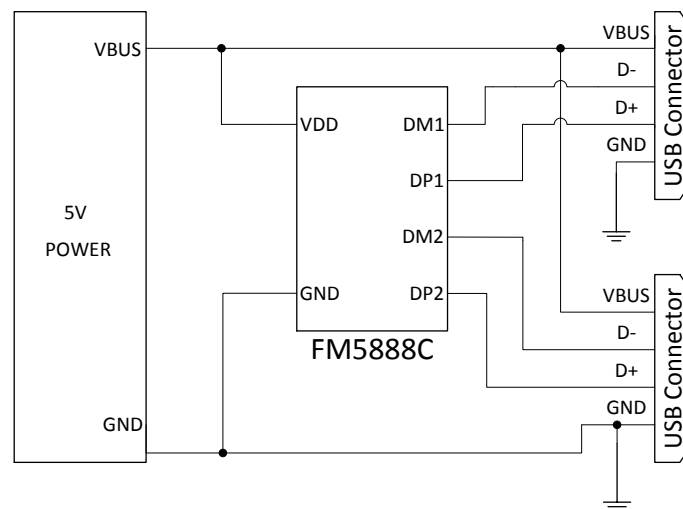

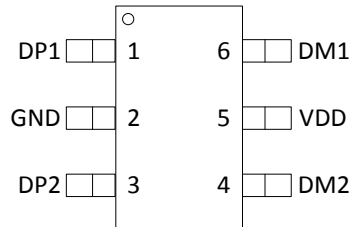
5 PIN FUNCTION
FM5888C (SOT23-6)
(TOP VIEW)

NO.	NAME	TYPE	DESCRIPTION
1	DP1	I/O	Connected to the D+ or D- line of USB connector, provide the correct voltage with attached portable equipment for DCP detection.
2	GND	G	Ground connection
3	DP2	I/O	Connected to the D+ or D- line of USB connector, provide the correct voltage with attached portable equipment for DCP detection.
4	DM2	I/O	Connected to the D+ or D- line of USB connector, provide the correct voltage with attached portable equipment for DCP detection.
5	VDD	P	Power supply. Connect a ceramic capacitor with a value of 0.1uF or greater from the VDD pin to GND as close to the device as possible.
6	DM1	I/O	Connected to the D+ or D- line of USB connector, provide the correct voltage with attached portable equipment for DCP detection.

(1) G=Ground, I=input, O=output, P=Power

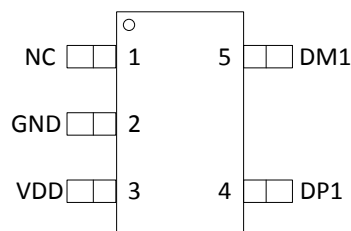
FM5887C (SOT23-5)
(TOP VIEW)

NO.	NAME	TYPE	DESCRIPTION
1	NC	-	No connect pin. Can be grounded or left floating.
2	GND	G	Ground connection
3	VDD	P	Power supply. Connect a ceramic capacitor with a value of 0.1uF or greater from the VDD pin to GND as close to the device as possible.
4	DP1	I/O	Connected to the D+ or D- line of USB connector, provide the correct voltage with attached portable equipment for DCP detection.
5	DM1	I/O	Connected to the D+ or D- line of USB connector, provide the correct voltage with attached portable equipment for DCP detection.

(1) G=Ground, I=input, O=output, P=Power

6 SPECIFICATIONS

6.1 ABSOLUTE MAXIMUM RATING

Over recommended junction temperature range, voltages are referenced to GND (unless otherwise noted)

Parameters		MIN	MAX	UNIT
Voltage range	VDD	-0.3	7	V
	DP1, DM1, DP2, DM2 voltage	-0.3	5.5	
ESD rating	Human Body Model (HBM)		8K	V
Operating Junction Temperature	T _J	-40	125	°C
Storage Temperature Range	T _{STG}	-65	150	°C

(1) Stresses beyond those listed under Absolute Maximum Ratings may cause permanent damage to the device. Exposure to absolute-maximum-rated conditions for extended periods may affect device reliability.

6.2 RECOMMENDED OPERATING CONDITIONS

Voltages are referenced to GND (unless otherwise noted), positive current are into pins.

Parameters		MIN	MAX	UNIT
VDD	Input voltage of VDD	4.5	5.5	V
IVDD	Input current of VDD		260	uA
VDP1	DP1 data line input voltage	0	5.5	V
VDM1	DM1 data line input voltage	0	5.5	V
VDP2	DP2 data line input voltage	0	5.5	V
VDM2	DM2 data line input voltage	0	5.5	V
T _J	Operating Junction Temperature	-40	125	°C

6.3 ELECTRICAL CHARACTERISTICS

Conditions are $-40^{\circ}\text{C} \leq T_J \leq 125^{\circ}\text{C}$, $4.5\text{V} \leq \text{VDD} \leq 5.5\text{V}$. Typical values are at 25°C . All voltages are with respect to GND (unless otherwise noted).

Parameters		MIN	TYP	MAX	UNIT
VDD	Input voltage of VDD	4.5	5	5.5	V
IVDD	Input current of VDD		150	260	uA
Output Voltage					
VDP1	DP1 data line output voltage	2.57	2.70	2.84	V
VDM1	DM1 data line output voltage	2.57	2.70	2.84	V
VDP2	DP2 data line output voltage	2.57	2.70	2.84	V
VDM2	DM2 data line output voltage	2.57	2.70	2.84	V
Output impedance					
RDP1	DP1 data line output impedance	10	14	18	KΩ
RDM1	DM1 data line output impedance	10	14	18	KΩ
RDP2	DP2 data line output impedance	10	14	18	KΩ
RDM2	DM2 data line output impedance	10	14	18	KΩ

7 APPLICATION INFORMATION

The FM5887C and FM5888C only provide the correct electrical signatures on the data line of USB charger port and do not provide any power for the VBUS.

The FM5887C and FM5888C provide 12-W USB Charger (Apple 2.4A), the DP1 pin is connected to D+ line and the DM1 pin is connect to the D- line. This is showed in Figure below.

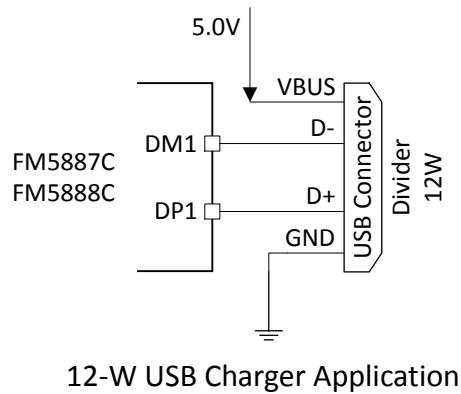

8 Outline Information

8.1 FM5888C (SOT23-6)

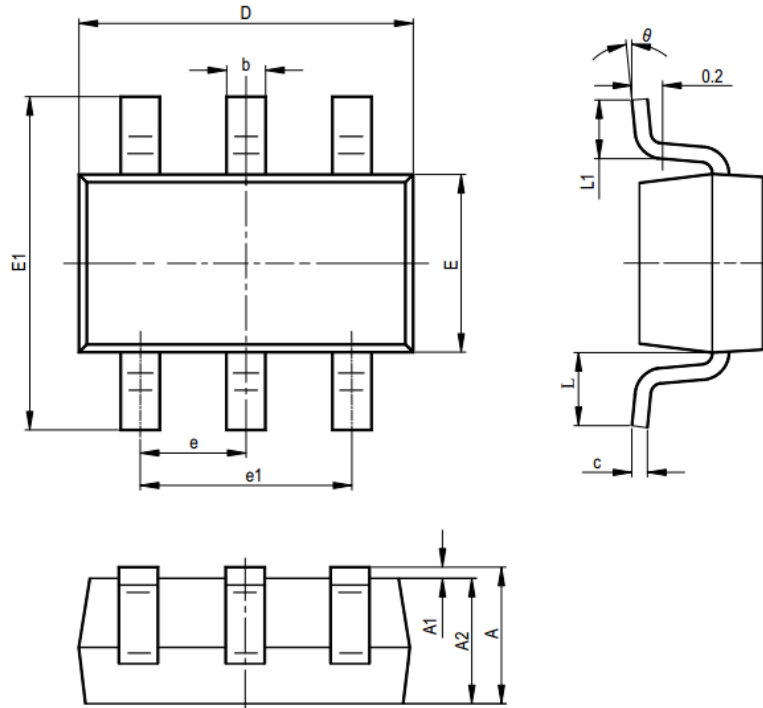

Symbol	Dimensions In Millimeters		Dimensions In Inches	
	Min	Max	Min	Max
A	1.050	1.250	0.041	0.049
A1	0.000	0.100	0.000	0.004
A2	1.050	1.150	0.041	0.045
b	0.300	0.500	0.012	0.020
c	0.100	0.200	0.004	0.008
D	2.820	3.020	0.111	0.119
E	1.500	1.700	0.059	0.067
E1	2.650	2.950	0.104	0.116
e	0.950		0.037	
e1	1.800	2.000	0.071	0.079
L	0.300	0.600	0.012	0.024
θ	0°	8°	0°	8°

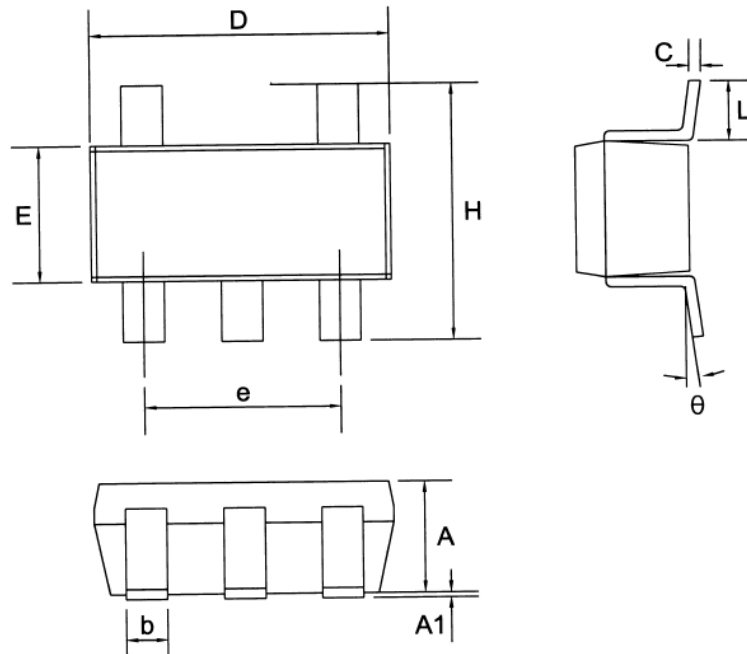
8.2 FM5887C (SOT23-5)

Symbol	Dimensions In Millimeters		Dimensions In Inches	
	Min	Max	Min	Max
A1	0.000	0.100	0.000	0.004
A	1.050	1.150	0.041	0.045
b	0.300	0.500	0.012	0.020
C	0.100	0.200	0.004	0.008
D	2.820	3.020	0.111	0.119
E	1.500	1.700	0.059	0.067
H	2.650	2.950	0.104	0.116
e	1.800	2.000	0.071	0.079
L	0.300	0.600	0.012	0.024
θ	0°	8°	0°	8°

X-ON Electronics

Largest Supplier of Electrical and Electronic Components

Click to view similar products for [USB Interface IC](#) category:

Click to view products by [Fuman](#) manufacturer:

Other Similar products are found below :

[CY7C69356-48LTXC](#) [CYUSB2304-68LTXI](#) [CY7C65632-48AXCT](#) [CYPD2119-24LQXI](#) [USB2227-NU-11](#) [USB3319C-GJ-TR](#) [USB3370B-EZK-TR](#) [PTN5150AHXMP](#) [CG7648AM](#) [CY7C65215A-32LTXI](#) [CYPD2120-24LQXI](#) [CYUSB3014-BZXCT](#) [CYWB0164BB-BZXI](#) [CYWB0224ABS-BZXI](#) [CY7C65211A-24LTXI](#) [USB3803CI-1-GL-TR](#) [CYPD2122-20FNXIT](#) [LIF-UC120-SWG36ITR50](#) [UPD360-B/6HX](#) [UPD360-A/6HX](#) [CP2102NP1174GM](#) [CY7C65642-28LTXCT](#) [CG8454AM](#) [CYUSB2025-BZXI](#) [DPO2039DABQ-13](#) [UPD720211K8-711-BAL-A](#) [CYPM1111-40LQXI](#) [CY7C65216D-32LTXI](#) [USB3317C-GJ-TR](#) [FM5888C](#) [CH340N](#) [CH224K](#) [XPD319B](#) [XPD738B20](#) [AT5102SG](#) [SL2.1s](#) [CY7C68034-56LTXC](#) [CYUSB3302-68LTXI](#) [TUSB213IRGYT](#) [TUSB213RGYT](#) [TUSB214RWBT](#) [USB2517I-JZX-TR](#) [USB3318-CP](#) [USB3343-CP](#) [USB3503T-I/ML](#) [CHY100D-TL](#) [STUSB1602AQTR](#) [TUSB214IRWBT](#) [TUSB8043RGCT](#) [USB3319C-CP-TR](#)