



#### Features

- Broadband frequency range: 0.1 to 3.0GHz
- Low insertion loss: 0.70dB @2.7GHz
- High P0.1dB of 43dBm
- Off Ports, "Open Type"
- Three pin GPIO control Interface for multi-on application
- Small QFN (10-pin, 1.1mm x 1.5mm x 0.45mm) package , MSL1

#### Applications

- GSM/WCDMA/LTE band and mode switching
- Antenna tuning switch

#### Description

The FM8544A is a CMOS silicon-on-insulator (SOI), single- pole, four-throw (SP4T) switch. The high linearity and ruggedness performance and extremely low insertion loss makes the device an ideal choice for GSM/WCDMA/LTE handset antenna tuning application. The FM8544A SP4T switch is provided in a compact QFN 1.1mm x 1.5mm x 0.45mm package. A functional block diagram is shown in Figure 1. The pin configuration and package are shown in Figure 2. Signal pin assignments and functional pin descriptions are provided in Table 1.

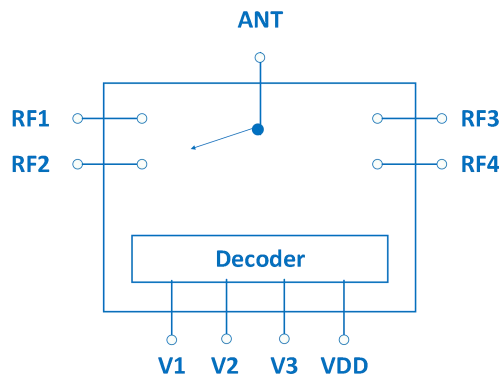

Figure 1 Functional Block Diagram

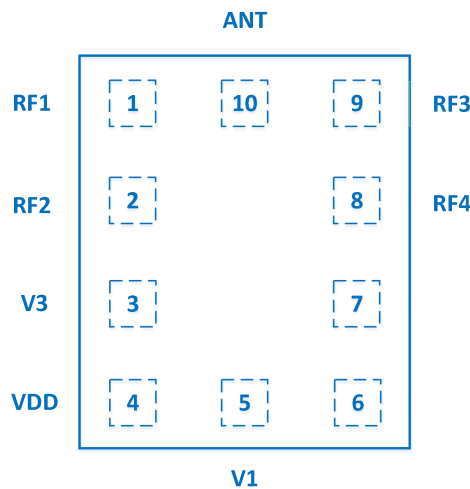

Figure 2 Pin-Out(Top View)



#### Function Characteristics

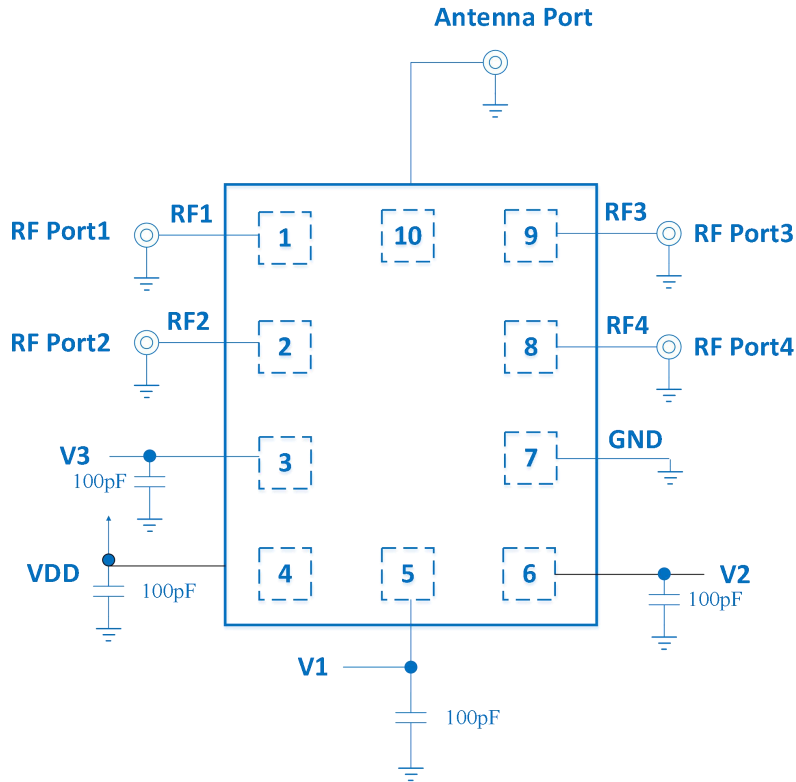

Figure 3 Application Circuit

Table 1 Pin Description

No.	Name	Description	No.	Name	Description
1	RF1	RF Port 1	6	V2	Logic Control Voltage 2
2	RF2	RF Port 2	7	GND	Ground
3	V3	Logic Control Voltage 3	8	RF4	RF Port 4
4	VDD	DC Power Supply	9	RF3	RF Port 3
5	V1	Logic Control Voltage 1	10	ANT	Antenna Port

Table 2 VC Truth Table of for RF Channel Operating Mode

V1	V2	V3	RF Channel Operating Mode
Low	Low	High	All Ron
Low	High	High	ANT to RF1 and RF2



### FM8544A (文件编号: S&CIC2065)

### SP4T Switch for 4G/5G Applications

High	Low	High	ANT to RF3 and RF4
Low	Low	Low	ANT to RF1
Low	High	Low	ANT to RF2
High	Low	Low	ANT to RF3
High	High	Low	ANT to RF4
High	High	High	All isolation

## Electrical Characteristics

Table 3 Absolute Maximum Ratings

Parameter	Symbol	Min	Max	Unit
DC Supply Voltage	VDD	-0.3	+4.8	V
Digital Control Voltage	VC	-0.3	+3.3	V
RF Input Peak Power				
Max Input Power between any combination of RF ports or ground VRF, VDD = 2.85VDC, VCTL1/2 = 0/1.8VDC, Temp = 25°C @20% DC	PIN		+43	dBm
Max voltage between any combination of RF ports or ground VRF, VDD = 2.85VDC, VCTL1/2 = 0/1.8VDC, Temp = 25°C @20% DC	Vpeak		60	V
Device Operating Temperature	TOP	-40	+90	°C
Device Storage Temperature	TSTG	-55	+150	°C
Electrostatic Discharge				
Human Body Model (HBM), Class 2	VESD(HBM)		1000	V
Charged Device Model (CDM), Class III	VESD(CDM)		1000	V

### Notice

Exposure to maximum rating conditions for extended periods may reduce device reliability. There is no damage to device with only one parameter set at the limit and all other parameters set at or below their nominal value. Exceeding any of the limits listed here may result in permanent damage to the device.

**Table 4 Recommended Operating Conditions**

Parameter	Symbol	MIN	TYP	MAX	Unit
Operating Frequency	F <sub>0</sub>	0.1		3.0	GHz
DC Supply Voltage	VDD	2.5	2.8	4.2	V
Logic Control Voltage High	VCH	1.0	1.8	3.0	V
Logic Control Voltage Low	VCL	0	0	0.3	V

**Table 5 Nominal Operating Parameters**

Parameter	Symbol	Specification			Unit	Condition
		MIN	TYP	MAX		
Normal Condition	VDD=2.8V, VCH=1.8V, VCL=0V, PIN=0dBm, ZO=50Ω, TA=25°C, Unless Otherwise Stated					
DC Performances						
DC Supply Current	IDD		80	120	μA	
Current on Logic Control	IC		1	5	μA	
Startup Time	TON		10	20	μs	50% of final VDD to 90% of the final RF
Switching Speed	TSW		4	5	μs	50% of final VC to 90%/10% of the final RF
RF Performances						
Insertion Loss (ANT to RF1/2/3/4)	IL		0.30	0.35	dB	F <sub>0</sub> =0.8 to 1.0GHz
			0.50	0.60	dB	F <sub>0</sub> =1.0 to 2.2GHz
			0.70	0.85	dB	F <sub>0</sub> =2.2 to 3.0GHz
Isolation (ANT to RF1/2/3/4)	ISO	21	23		dB	F <sub>0</sub> =0.8 to 1.0GHz
		17	20		dB	F <sub>0</sub> =1.0 to 2.2GHz
		12	14		dB	F <sub>0</sub> =2.2 to 3.0GHz
Return Loss (ANT to RF1/2/3/4)	RL		15		dB	F <sub>0</sub> =0.8 to 3.0GHz
On Resistance (ANT to RF1/2/3/4)	RON		1.0	1.5	Ω	Switch On Path@DC
Off Capacitance (ANT to RF1/2/3/4)	COF F		150	170	fF	Switch Off Path@500MH



### FM8544A (文件编号: S&CIC2065)

### SP4T Switch for 4G/5G Applications

Peak RF Operating Voltage	V <sub>RF</sub>	60		V	F <sub>0</sub> =950MHz, 20% duty cycle
LTE TX Harmonic (RF1/2/3/4 to ANT)	2F <sub>0</sub>	-70	-65	dBm	F <sub>0</sub> = 0.7 to 2.7GHz @+26dBm
	3F <sub>0</sub>	-75	-65	dBm	
GSM LB Harmonic (RF1/2/3/4 to ANT)	2F <sub>0</sub>	-60	-52	dBm	F <sub>0</sub> = 824 to 915MHz @+35dBm
	3F <sub>0</sub>	-70	-60	dBm	
GSM HB Harmonic (RF1/2/3/4 to ANT)	2F <sub>0</sub>	-65	-58	dBm	F <sub>0</sub> = 1710 to 2690MHz @+33dBm
	3F <sub>0</sub>	-70	-60	dBm	

### Tape and Reel Dimensions

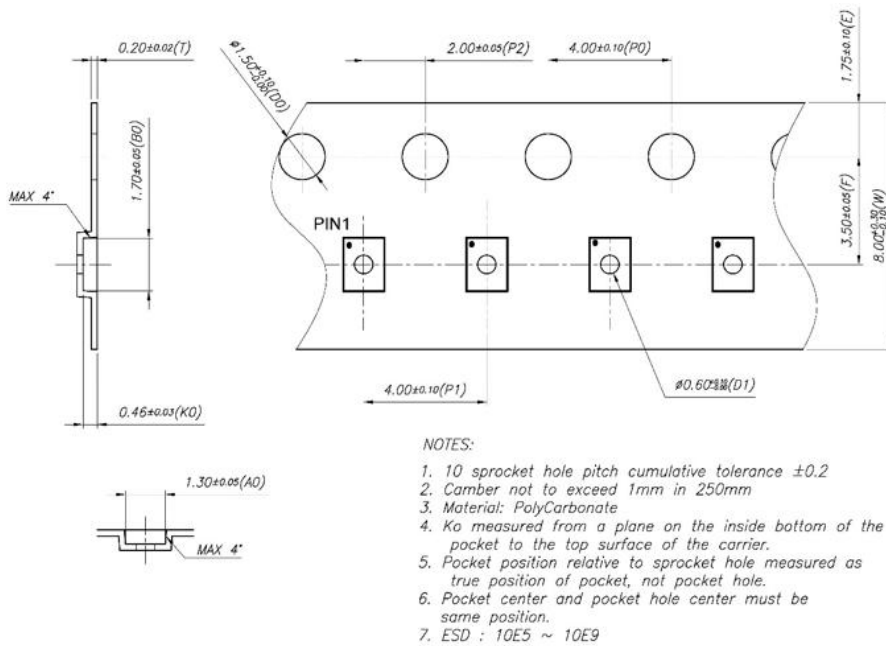

Figure 6 Tape and Reel Dimensions



#### Reflow Chart

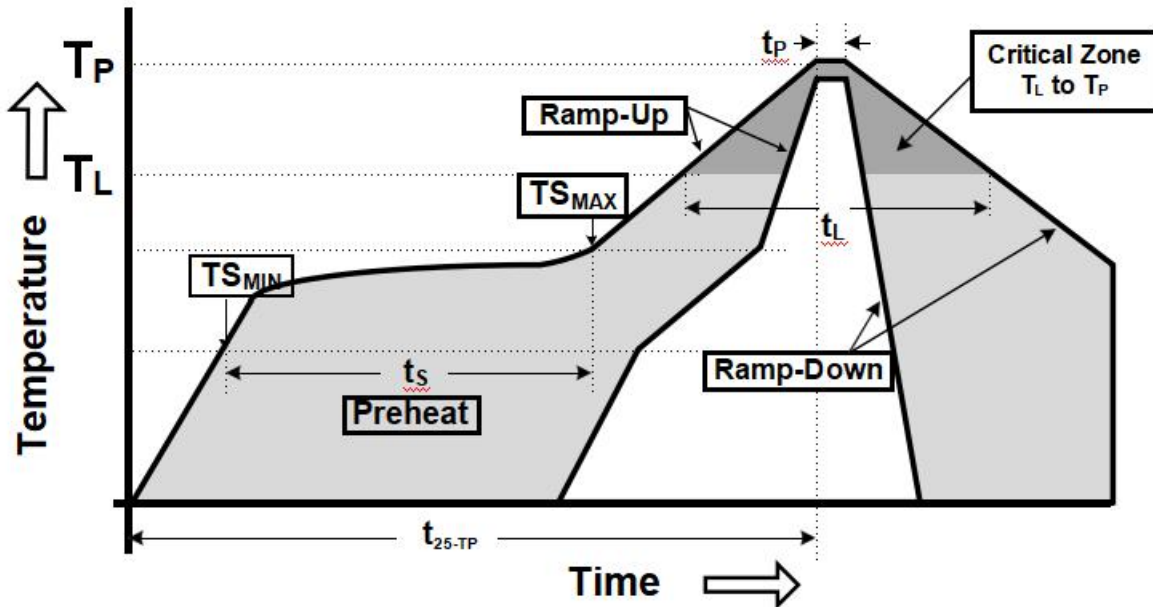

Figure 7 Recommended Lead-Free Reflow Profile

Table 7 Reflow Chart Parameters

Reflow Profile	Parameter
Preheat Temperature(TSMIN to TS MAX)	150°C to 200°C
Preheat Time(t <sub>s</sub> )	60 to 180 Seconds
Ramp-Up Rate(TS MAX to T <sub>P</sub> )	3°C/s MAX
Time Above T <sub>L</sub> 217°C(t <sub>L</sub> )	60 to 150 Seconds
Peak Temperature ( T <sub>P</sub> )	260°C
Time within 5°C of Peak Temperature(t <sub>p</sub> )	20 to 40 Seconds
Ramp-Down Rate(TS MAX to T <sub>P</sub> )	6°C/s MAX
Time for 25°C to Peak Temperature(t <sub>25-TP</sub> )	8 Minutes MAX

#### ESD Sensitivity

Integrated circuits are ESD sensitive and can be damaged by static electric charge. Proper ESD protection techniques should be applied when devices are operating.

#### RoHS Compliant

This product does not contain lead, mercury, cadmium, hexavalent chromium, polybrominated biphenyls (PBB) and polybrominated diphenyl ethers (PBDE), and is considered RoHS compliant.

## X-ON Electronics

Largest Supplier of Electrical and Electronic Components

*Click to view similar products for [RF Switch ICs](#) category:*

*Click to view products by [Fuman](#) manufacturer:*

Other Similar products are found below :

[MA8334-001](#) [MASW-004100-11930W](#) [MASW-008853-TR3000](#) [BGS13SN8E6327XTSA1](#) [BGSF18DM20E6327XUMA1](#)  
[BGSX210MA18E6327XTSA1](#) [BGSX212MA18E6327XTSA1](#) [SKY13446-374LF](#) [CG2185X2](#) [CG2415M6](#) [MA4SW210B-1](#) [MA4SW410B-1](#)  
[MASW-002102-13580G](#) [MASW-008543-001SMB](#) [MASW-008955-TR3000](#) [BGS 12PL6 E6327](#) [BGS1414MN20E6327XTSA1](#)  
[BGS1515MN20E6327XTSA1](#) [BGSA11GN10E6327XTSA1](#) [SKY13374-397LF](#) [CG2430X1-C2](#) [CG2415M6-C2](#) [AS222-92LF](#) [SW-314-PIN](#)  
[UPG2162T5N-E2-A](#) [MASWSS0204TR-3000](#) [MASWSS0201TR](#) [MASWSS0181TR-3000](#) [MASW-007588-TR3000](#) [MASW-004103-13655P](#)  
[MASW-003102-13590G](#) [MASWSS0202TR-3000](#) [MASW-008543-TR3000](#) [MA4SW310B-1](#) [MA4SW310](#) [MA4SW210](#) [MA4SW110](#) [SW-](#)  
[313-PIN](#) [CG2430X1](#) [SKY13405-490LF](#) [SKYA21001](#) [BGSF 18DM20 E6327](#) [SKY13415-485LF](#) [MMS008PP3](#) [BGS13PN10E6327XTSA1](#)  
[SKY13319-374LF](#) [BGS14PN10E6327XTSA1](#) [SKY12213-478LF](#) [SKY13404-466LF](#) [SKY85605-11](#)