

# ESP D & TN Series



|   |   |
|---|---|
| <b>LPZ</b><br>0 <sub>A</sub> → 3                    | <b>FULL MODE</b><br>Bonding +<br>Equipment<br>Protection  |
| <b>SIGNAL/<br/>TELECOM</b><br>TEST CAT<br>D + C + B | <b>e</b><br><b>ENHANCED</b><br>Low let-through<br>voltage |
| <b>LOW IN-LINE<br/>RESISTANCE</b><br>9.4 Ω          | <b>CURRENT<br/>RATING</b><br>300 mA                       |

Combined Category D, C, B tested protector (to BS EN 61643) suitable for most twisted pair signalling applications. Available for working voltages of up to 6, 15, 30, 50 and 110 Volts. ESP TN suitable for Broadband, POTS, dial-up, T1/E1, lease line and \*DSL telephone applications. For use at boundaries up to LPZ 0<sub>A</sub> to protect against flashover (typically the service entrance location) through to LPZ 3 to protect sensitive electronic equipment.

## Features and benefits

- ✓ Very low let-through voltage (enhanced protection to BS EN 62305) between all lines - Full Mode protection
- ✓ Full mode design capable of handling partial lightning currents as well as allowing continual operation of protected equipment
- ✓ Repeated protection in lightning intense environments
- ✓ Low in-line resistance minimises unnecessary reductions in signal strength
- ✓ Strong, flame retardant, ABS housing
- ✓ Supplied ready for flat mounting on base or side
- ✓ Built-in DIN rail foot for simple clip-on mounting to top hat DIN rails
- ✓ Colour coded terminals give a quick and easy installation check - grey for the dirty (line) end and green for the clean end
- ✓ Screen terminal enables easy connection of cable screen to earth
- ✓ Substantial earth stud to enable effective earthing
- ✓ Integral earthing plate for enhanced connection to earth via a CME kit
- ✓ ESP 06D and ESP 50D have PADS reference 086/000551 (ESP 06D) and 086/000553 (ESP 50D)
- ✓ ESP TN is suitable for telecommunication applications in accordance with Telcordia and ANSI Standards (see **Application Note AN005**)

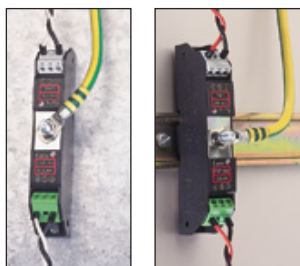

Protectors can be flat mounted via their base (left) or side, or mounted on top hat DIN rail (right) via an integral spring loaded DIN rail foot

## Application

Use on twisted pair lines, e.g. those found in process control equipment, modems and computer communications interfaces.

## Installation

Connect in series with the data communication or signal line either near where it enters or leaves the building or close to the equipment being protected (e.g. within its control panel). Either way, it must be very close to the system's earth star point. Install protectors either within an existing cabinet/cubicle or in a separate enclosure.

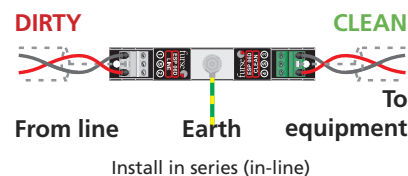

## Accessories

Combined Mounting/Earthing kits

### CME 4

Mount & earth up to 4 protectors

### CME 8

Mount & earth up to 8 protectors

### CME 16

Mount & earth up to 16 protectors

### CME 32

Mount & earth up to 32 protectors

Weatherproof enclosures

### WBX 2/G

For use with up to 2 protectors

### WBX 3, WBX 3/G

For use with up to 3 protectors

### WBX 4, WBX 4/GS

For use with a CME 4 and up to 4 protectors

### WBX 8, WBX 8/GS

For use with a CME 8 and up to 8 protectors

### WBX 16/2/G

For use with one or two CME 16 and up to 32 protectors

## Technical specification

| Electrical specification                  | ESP 06D      | ESP 15D      | ESP 30D      | ESP 50D      | ESP 110D     | ESP TN       |
|---|--------------|--------------|--------------|--------------|--------------|--------------|
| Nominal voltage <sup>1</sup>              | 6 V          | 15 V         | 30 V         | 50 V         | 110 V        | -            |
| Maximum working voltage $U_c^2$           | 7.79 V       | 19 V         | 37.1 V       | 58 V         | 132 V        | 296 V        |
| Current rating (signal)                   | 300 mA       |              |              |              |              |              |
| In-line resistance (per line $\pm 10\%$ ) | 9.4 $\Omega$ | 9.4 $\Omega$ | 9.4 $\Omega$ | 9.4 $\Omega$ | 9.4 $\Omega$ | 4.4 $\Omega$ |
| Bandwidth (-3 dB 50 $\Omega$ system)      | 800 kHz      | 2.5 MHz      | 4 MHz        | 6 MHz        | 9 MHz        | 20 MHz       |

| Transient specification  | ESP 06D | ESP 15D | ESP 30D | ESP 50D | ESP 110D | ESP TN |
|--|---------|---------|---------|---------|----------|--------|
| <b>Let-through voltage</b> (all conductors) <sup>3</sup> Up                |         |         |         |         |          |        |
| C2 test 4 kV 1.2/50 $\mu$ s, 2 kA 8/20 $\mu$ s to BS EN/EN/IEC 61643-21    | 12.0 V  | 25.0 V  | 44.0 V  | 78.0 V  | 155 V    | 395 V  |
| C1 test 1 kV, 1.2/50 $\mu$ s, 0.5 kA 8/20 $\mu$ s to BS EN/EN/IEC 61643-21 | 11.5 V  | 24.5 V  | 43.5 V  | 76.0 V  | 150 V    | 390 V  |
| B2 test 4 kV 10/700 $\mu$ s to BS EN/EN/IEC 61643-21                       | 10.0 V  | 23.0 V  | 42.5 V  | 73.0 V  | 145 V    | 298 V  |
| 5 kV, 10/700 $\mu$ s <sup>4</sup>  | 10.5 V  | 23.8 V  | 43.4 V  | 74.9 V  | 150 V    | 300 V  |

| Maximum surge current                               |                                 | ESP 06D | ESP 15D | ESP 30D | ESP 50D        | ESP 110D | ESP TN |
|---|---------------------------------|---------|---------|---------|----------------|----------|--------|
| D1 test 10/350 $\mu$ s to BS EN/EN/IEC 61643-21     | - per signal wire<br>- per pair |         |         |         | 2.5 kA<br>5 kA |          |        |
| 8/20 $\mu$ s to ITU-T K.45:2003, IEEE C62.41.2:2002 | - per signal wire<br>- per pair |         |         |         | 10 kA<br>20 kA |          |        |

| Mechanical specification             | ESP 06D             | ESP 15D | ESP 30D | ESP 50D | ESP 110D | ESP TN |
|--------------------------------------|---------------------|---------|---------|---------|----------|--------|
| Temperature range                    | -40 to +80 °C       |         |         |         |          |        |
| Connection type                      | Screw terminal      |         |         |         |          |        |
| Conductor size (stranded)            | 2.5 mm <sup>2</sup> |         |         |         |          |        |
| Earth connection                     | M6 stud             |         |         |         |          |        |
| Case material                        | ABS UL94 V-0        |         |         |         |          |        |
| Weight - unit<br>- packaged (per 10) | 0.08 kg<br>0.85 kg  |         |         |         |          |        |
| Dimensions                           |                     |         |         |         |          |        |

<sup>1</sup> Nominal voltage (DC or AC peak) measured at < 5  $\mu$ A (ESP 15D, ESP 30D, ESP 50D, ESP 110D) and < 200  $\mu$ A (ESP 06D).

<sup>2</sup> Maximum working voltage (DC or AC peak) measured at < 1 mA leakage (ESP 15D, ESP 30D, ESP 50D, ESP 110D), < 10 mA (ESP 06D) and < 10  $\mu$ A (ESP TN).

<sup>3</sup> The maximum transient voltage let-through of the protector throughout the test ( $\pm 10\%$ ), line to line & line to earth, both polarities. Response time < 10 ns.

<sup>4</sup> Test to IEC 61000-4-5:2006, ITU-T (formerly CCITT) K.20, K.21 and K.45, Telcordia GR-1089-CORE, Issue 2:2002, ANSI TIA/EIA/IS-968-A:2002 (formerly FCC Part 68).

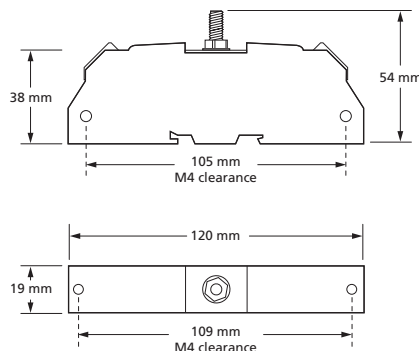

Derivatives of these protectors are available ready-boxed to IP66, for use in damp or dirty environments. Slim Line (ESP SL), ATEX (ESP SLX) and PCB mount (ESP PCB) versions are also available. If your system requires a protector with a very low resistance or higher current, see the ESP E & H Series. Also use the ESP E Series for systems needing a higher bandwidth. Protectors for 3-wire (ESP SL/3W) and RTD (ESP RTD, ESP SL RTD) are available, as are the space saving protectors (ESP Q, ESP SL Series). The ESP KT and TN Series are additional protectors specifically for telephone lines. The ESP KS Series are protectors for data and signal lines on an LSA-PLUS module.

## **X-ON Electronics**

Largest Supplier of Electrical and Electronic Components

*Click to view similar products for [furse manufacturer](#):*

Other Similar products are found below :

[WBX4](#) [ESP 06D](#) [ESP30D](#) [ESPTN/BX](#) [ESP240-5A](#)