

Combined Category D, C, B tested protector (to BS EN 61643) suitable for RF systems using coaxial cables at frequencies between DC and 2.7 GHz and where DC power is present. Suitable for RF systems with power up to 2.3 kW. For use at boundaries up to LPZ 0_A to protect against flashover (typically the service entrance location) through to LPZ 3 to protect sensitive electronic equipment.

Features and benefits

- ✓ Restricts let-through voltage below damage levels of interface circuitry
- ✓ Very low attenuation and near unity VSWR over a wide range of frequencies ensure the protectors do not impair system performance
- ✓ Wide bandwidth means a single product is suitable for a range of applications, including the transmission of DC power
- ✓ Easily mounted and earthed via fixtures on the base of the unit
- ✓ Available with N, 7/16 DIN and BNC connectors
- ✓ Additional mounting plates give increased flexibility
- ✓ Robust white bronze plated aluminium housing (silver plate option)

Application

Use on coaxial cables to protect RF transmitter and receiver systems, including electronics located at the antenna or dish. Typical examples include cell sites, military communications, satellite earth stations and pager systems. They can be used in applications where DC power is required to pass to the equipment.

Part numbering system

Furse RF protectors have six digit part codes, prefixed with ESP RF. The selected digits define the exact specification of the required protector, e.g. **ESP RF AABCDE**

Connector type - ESP RF AAxxxx The first 2 digits refer to the connector type:

11 - N type female **AA** - 7/16 DIN type female **44** - BNC female

Line impedance - ESP RF xxBxxx 3rd digit refers to the line impedance. Currently only one option:

1 - 50 Ω transmission line.

Gas Discharge Tube (GDT) selection - ESP RF xxxCxx Select the 4th digit from the table at the bottom of next page.

Selection of the correct GDT is critical in the effectiveness of using these protectors. For the correct GDT, take the maximum RF power or voltage of the system and select a GDT with a voltage/power handling greater than the system.

Important note: When using the peak RF voltage to select the GDT, if the system is a multi-carrier system the (in phase) peak RF voltage can be calculated as the total of all the single carrier peak voltages on the transmission line.

Protector rating - ESP RF xxxxDx 5th digit specifies the protector rating.

- 1** - Higher specification
- 2** - Standard specification

Case plating - ESP RF xxxxE 6th digit specifies the case plating.

- 1** - White bronze
- 2** - Silver

Installation

In a building, connect in series with the coaxial cable near where it enters or leaves the structure, or close to the equipment being protected. On a mast, connect in series with the coaxial cable near the antenna/dish being protected. Install in a radio communications room, an existing cabinet or a suitable enclosure.



ESP RF 111A21 with N female connectors installed in series



ESP RF 111121 on a coaxial cable running between an antenna and an RF receiver

Accessories

ESP RF BK1

Straight mounting plates

ESP RF BK2

90° angled mounting plates

ESP RF BK3

Bulkhead through mounting plate (single)

ESP RF BK4

Bulkhead through mounting plate (for 4 products)

ESP RF GDT-x

Replacement gas discharge tubes (Where x is the correct GDT part code digit for your system. See GDT selection).

Technical note

These protectors are based on a continuous transmission line with a GDT connected between this line and screen/earth, and are suited for applications where DC is required to pass to the equipment.

Technical specification

IMPROVED
ESP RF xx1x21

Electrical specification

Gas Discharge Tube voltage	90 V	150 V	230 V	350 V	470 V	600 V
Maximum working voltage U_c (RMS) ¹	51 V	85 V	130 V	200 V	265 V	340 V
Characteristic impedance	50 Ω					
Bandwidth	DC-2.7 GHz					
Voltage standing wave ratio	≤ 1.1					
Insertion loss over bandwidth	≤ 0.1 dB					
Maximum power ¹	40 W	120 W	280 W	650 W	1.15 kW	1.90 kW

Transient specification

ESP RF xx1x21

Let-through voltage (all conductors)² Up

C2 test 4 kV 1.2/50 μ s, 2 kA 8/20 μ s to BS EN/EN/IEC 61643-21	< 700 V	< 650 V	< 700 V	< 800 V	< 900 V	< 1050 V
C1 test 1 kV, 1.2/50 μ s, 0.5 kA 8/20 μ s to BS EN/EN/IEC 61643-21	< 550 V	< 450 V	< 550 V	< 650 V	< 800 V	< 950 V
B2 test 4 kV 10/700 μ s to BS EN/EN/IEC 61643-21	< 400 V	< 350 V	< 450 V	< 550 V	< 730 V	< 800 V
5 kV, 10/700 μ s ³	< 430 V	< 370 V	< 470 V	< 580 V	< 750 V	< 830 V

Maximum surge current⁴

D1 test 10/350 μ s to BS EN/EN/IEC 61643-21	2.5 kA
8/20 μ s to IEC 61643-21, IEC 61643-21, IEC 61643-21	20 kA

Mechanical specification

	ESP RF 111x21	ESP RF AA1x21	ESP RF 441x21
Temperature range	-40 to +80 °C		
Connection type	N female	7/16 DIN female	BNC female
Earth connection	Via mounting fixtures		
Case material	Aluminium, white bronze plated		
Weight - unit	120 g	190 g	90 g
- packaged	140 g	210 g	110 g
Dimensions	See diagrams below		

¹ The maximum RF working voltage and maximum power for the protectors is dependent on the GDT selected. See 'Gas Discharge Tube selection' below.

² The maximum transient voltage let-through of the protector throughout the test ($\pm 10\%$). Response time < 10 ns. This let-through voltage represents a deviation from the applied signal voltage, present at the time of the test.

³ Test to IEC 61000-4-5:2006, ITU-T (formerly CCITT) K.20, K.21 and K.45, Telcordia GR-1089-CORE, Issue 2:2002, ANSI TIA/EIA/IS-968-A:2002 (formerly FCC Part 68).

⁴ The installation and connections external to the protector may limit the capability of the protector.

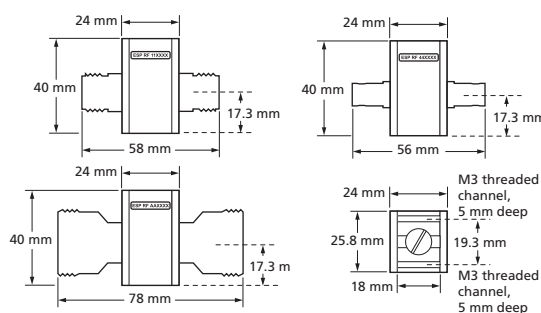

ESP RF BK1

Straight mounting bracket, 53 x 26.3 x 3 mm
Two M4 clearance mounting holes, 16.3 mm apart

ESP RF BK2

90° mounting bracket, 33 x 26.3 x 3 mm, 20 x 26.3 x 3 mm

Two M4 clearance mounting holes, 16.3 mm apart, 14 mm from fold line

ESP RF BK3

90° mounting bracket, 50 x 24 x 1.5 mm, 60 x 24 x 1.5 mm

Two M5 clearance mounting holes, 40 mm apart

ESP RF BK4

90° quad mounting bracket, 50 x 24 x 1.5 mm, 210 x 24 x 1.5 mm

Five M5 clearance mounting holes, various spacings

(Mounting brackets supplied with screws for fixing to protector)

Gas Discharge Tube selection

Max RF voltage V_{Peak}	Max RF voltage V_{RMS}	Max RF power 50 Ω system (P_{RMS}) with VSWR = 2:1	GDT voltage code	GDT part digit
72 V	51 V	40 W	90 V	1
120 V	85 V	120 W	150 V	2
185 V	130 V	280 W	230 V	3
280 V	200 V	650 W	350 V	4
375 V	265 V	1.15 kW	470 V	5
480 V	340 V	1.90 kW	600 V	6

Power levels have been de-rated to allow for real life 'worst case' conditions, calculated with VSWR as 2:1

For RF applications where the connected equipment is very sensitive to transient overvoltages, use the higher specification RF protectors. ESP CCTV/B and ESP CCTV/T are suitable for use on coaxial (or twisted pair) CCTV lines. For coaxial CATV lines, use the CATV/F.



- LPZ**
 $0_B \rightarrow 3$
- FULL MODE**
Bonding +
Equipment
Protection
- SIGNAL/
TELECOM**
TEST CAT
D + C + B
- ENHANCED**
Low let-through
voltage
- HIGH
BANDWIDTH**

Combined Category D, C, B tested protector (to BS EN 61643) suitable for RF systems (of power up to 150 W) using coaxial cables at frequencies between 50 MHz and 2.7 GHz to provide effective protection without impairing system performance. For use at boundaries up to LPZ 0_B to protect against flashover (typically the service entrance location) through to LPZ 3 to protect sensitive electronic equipment.

Features and benefits

- ✓ Very low let-through voltage (enhanced protection to BS EN 62305) between all lines - Full Mode protection
- ✓ Full mode design capable of handling partial lightning currents as well as allowing continual operation of protected equipment
- ✓ Repeated protection in lightning intense environments
- ✓ Superior transient protection to both Gas Discharge Tube (GDT) and Quarter Wave Stub (QWS) based protectors
- ✓ Very low attenuation and near unity VSWR over a wide range of frequencies ensure the protectors do not impair system performance
- ✓ Wide bandwidth means a single product is suitable for a range of applications
- ✓ Available with N, 7/16 DIN and BNC connectors
- ✓ Easily mounted and earthed via fixtures on the base of the unit that accept M3 and M5 screws or via mounting brackets
- ✓ Additional mounting plates give increased flexibility
- ✓ Robust white bronze plated aluminium housing (silver plate option)

Application

Use on coaxial cables to protect RF transmitter and receiver systems, including electronics located at the antenna or dish. Typical examples include cell sites, military communications, satellite earth stations, pager systems and emergency services communications systems.



ESP RF 111A11 installed on a coaxial cable running between an antenna and an RF receiver. Note the earth lead (behind the cable tray) attached to the mounting fixture

Installation

In a building, connect in series with the coaxial cable near where it enters or leaves the structure, or close to the equipment being protected. This should be as close as possible to the system's earth star point (to enable a good connection to earth). On a mast, connect in series with the coaxial cable near the antenna/dish being protected.

Install in a radio communications room, an existing cabinet or a suitable enclosure.

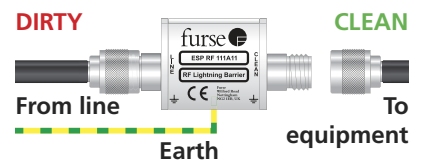

ESP RF 111A11 with N female connectors installed in series

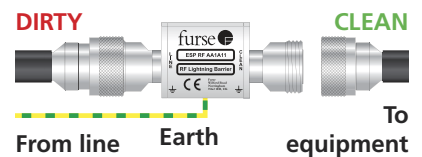

ESP RF AA1A11 with 7/16 DIN female connectors installed in series

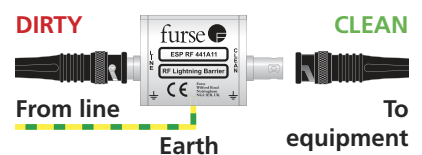

ESP RF 441A11 with BNC female connectors installed in series

Accessories

ESP RF BK1

Straight mounting plates

ESP RF BK2

90° angled mounting plates

ESP RF BK3

Bulkhead through mounting plate (single)

ESP RF BK4

Bulkhead through mounting plate (for 4 products)

ESP RF GDT-A

Replacement gas discharge tube

Technical specification

Electrical specification	IMPROVED	IMPROVED	IMPROVED
	ESP RF 111A11	ESP RF AA1A11	ESP RF 441A11
Maximum working voltage U_c (RMS)		86 V	
Maximum transmitted power (RMS)		150 W	
Characteristic impedance		50 Ω	
Bandwidth		50-2700 MHz	
Voltage standing wave ratio		≤ 1.2	
Insertion loss over bandwidth - 50-500 MHz		≤ 0.4 dB	
- 500-1,600 MHz		≤ 0.2 dB	
- 1.6-2.7 GHz		≤ 0.4 dB	
Maximum power		150 W	

Transient specification	ESP RF 111A11	ESP RF AA1A11	ESP RF 441A11
	Let-through voltage (all conductors) ¹ Up		
C2 test 4 kV 1.2/50 μ s, 2 kA 8/20 μ s to BS EN/EN/IEC 61643-21		24 V	
C1 test 1 kV, 1.2/50 μ s, 0.5 kA 8/20 μ s to BS EN/EN/IEC 61643-21		15 V	
B2 test 4 kV 10/700 μ s to BS EN/EN/IEC 61643-21		15 V	
5 kV, 10/700 μ s ²		20 V	
Maximum surge current ³			
D1 test 10/350 μ s to BS EN/EN/IEC 61643-21		1 kA	
8/20 μ s to ITU-T K.45:2003, IEEE C62.41.2:2002		10 kA	

Mechanical specification	ESP RF 111A11	ESP RF AA1A11	ESP RF 441A11
	Temperature range		-40 to +80 °C
Connection type	N female	7/16 DIN female	BNC female
Earth connection		Via mounting fixtures	
Case material, finish		Aluminium, white bronze plated	
Weight - unit	150 g	220 g	120 g
- packaged	170 g	240 g	160 g
Dimensions			

¹ The maximum transient voltage let-through of the protector throughout the test ($\pm 10\%$). Response time < 10 ns. This let-through voltage represents a deviation from the applied signal voltage, present at the time of the test.

² Test to IEC 61000-4-5:2006, ITU-T (formerly CCITT) K.20, K.21 and K.45, Telcordia GR-1089-CORE, Issue 2:2002, ANSI TIA/EIA/IS-968-A:2002 (formerly FCC Part 68).

³ The installation and connectors external to the protector may limit the capability of the protector.

Technical note

The high level of protection offered by these units comes from the addition of a high pass filter circuit which gives a very low let-through voltage. It should be noted that due to this high pass filter circuit no DC power can pass along the transmission line. This is referred to as "DC blocked".

Protectors with other connectors are available.

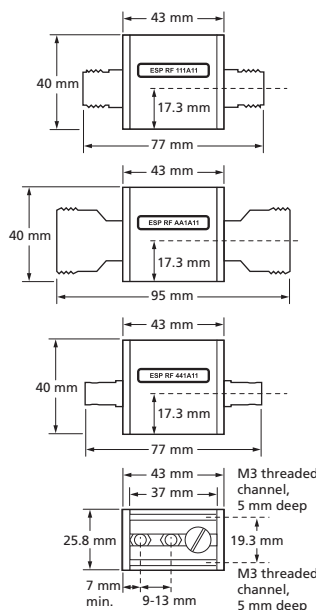

ESP RF BK1

Straight mounting bracket, 53 x 26.3 x 3 mm
Two M4 clearance mounting holes, 16.3 mm apart

ESP RF BK2

90° mounting bracket, 33 x 26.3 x 3 mm,
20 x 26.3 x 3 mm
Two M4 clearance mounting holes, 16.3 mm apart, 14 mm from fold line

ESP RF BK3

90° mounting bracket, 50 x 24 x 1.5 mm, 60 x 24 x 1.5 mm
Two M5 clearance mounting holes, 40 mm apart

ESP RF BK4

90° quad mounting bracket, 50 x 24 x 1.5 mm,
210 x 24 x 1.5 mm
Five M5 clearance mounting holes, various spacings

(Mounting brackets supplied with screws for fixing to protector)

For RF applications where DC power is present on the coaxial cable, use the alternative RF protectors. The ESP CCTV/B and ESP CCTV/T are suitable for use on coaxial (or twisted pair) CCTV lines. For coaxial CATV lines, use the ESP CATV/F.

X-ON Electronics

Largest Supplier of Electrical and Electronic Components

Click to view similar products for [furse manufacturer](#):

Other Similar products are found below :

[ESP415M1R](#) [WBX4](#) [ESP 240-5A/BX](#) [ESP 06D](#) [ESP30D](#) [ESPTN/BX](#) [ESP240-5A](#)